

micro **SYSTEM**

Servicing
Instructions
Type C Boilers
G.C.N: 41-116-04

LEAVE THESE INSTRUCTIONS
WITH THE END-USER



*The code of practice for the installation,
commissioning & servicing of central heating systems*

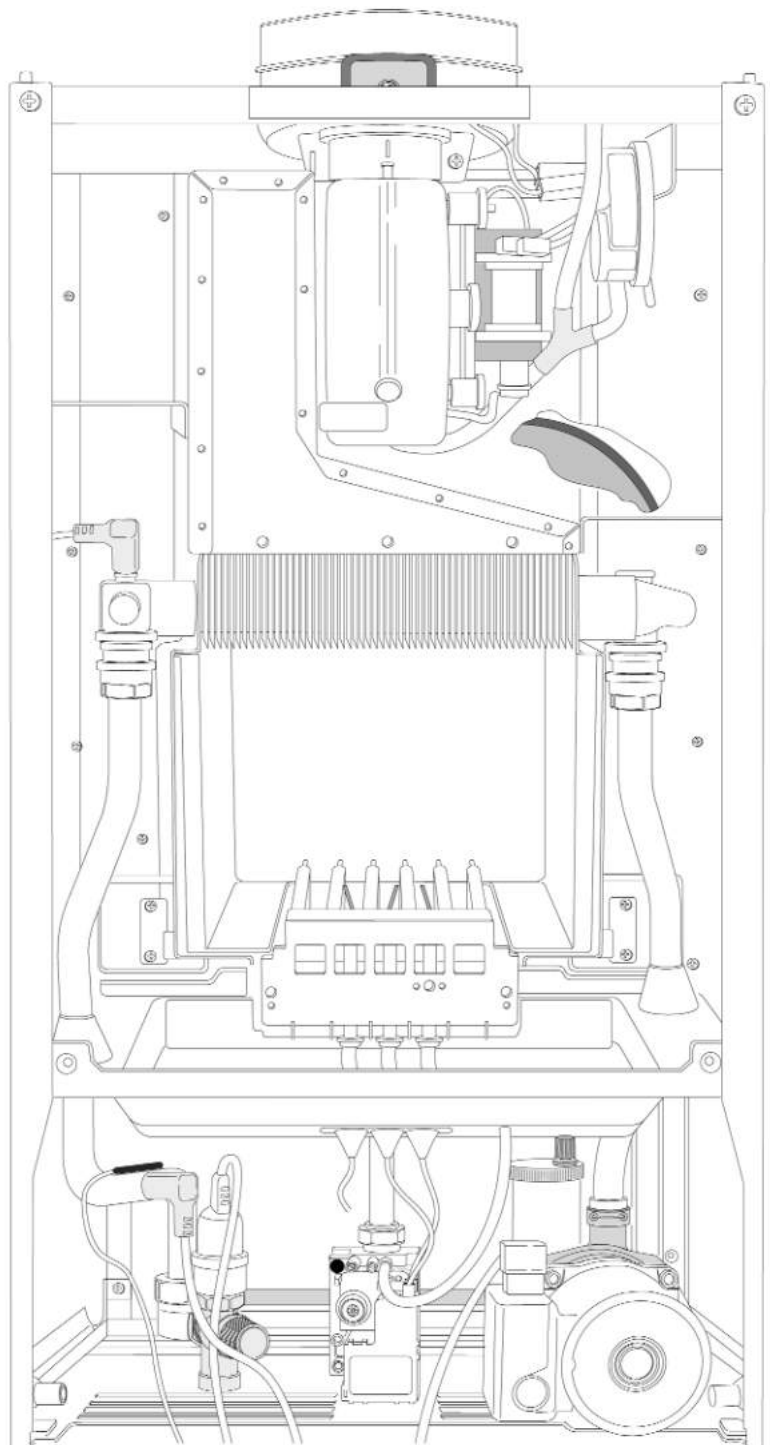

 **ARISTON**

Country of destination: GB

TABLE OF CONTENTS

1. **SERVICING INSTRUCTIONS**
 - 1.1 REPLACEMENT OF PARTS
 - 1.2 TO GAIN GENERAL ACCESS
 - *Removing the front panel*
 - *Removing the sealed chamber front cover*
 - *Removing the side panels*
 - 1.3 ACCESS TO THE COMBUSTION CHAMBER
 - *Removing the combustion cover*
 - *Removing the burner and jets*
 - *Removing the electrodes*
 - *Removing the main heat exchanger*
 - *Removing the air pressure switch*
 - *Removing the fan*
 - 1.4 SERVICING AND REMOVAL OF THE GAS VALVE
 - *Setting the gas pressures*
 - *Removing the spark generator*
 - *Removing the gas valve*
 - 1.5 ACCESS TO THE WATER CIRCUIT
 - *Removing the pump pressure switch*
 - *Removing the safety valve*
 - *Removing the automatic air vent*
 - *Removing the pump*
 - *Removing the pressure gauge*
 - *Removing the expansion vessel*
 - *Removing the overheat thermostat*
 - *Removing the frost thermostat*
 - *Removing the regulation thermostat*
 - 1.6 ACCESS TO THE CONTROL SYSTEM
 - *Checking the fuses*
 - *Removing the P.C.B.s*
2. **FAULT FINDING**
 - 2.1 FAULT FINDING GUIDE (FLOW-CHARTS)
3. **ELECTRICAL DIAGRAMS**
4. **SHORT SPARE PARTS LIST**

1. SERVICING INSTRUCTIONS

To ensure efficient safe operation, it is recommended that the boiler is serviced annually by a competent person.

Before starting any servicing work, ensure both the gas and electrical supplies to the boiler are isolated and the boiler is cool.

Before and after servicing, a combustion analysis should be made via the flue sampling point (please refer to the Installation Manual for further details).

After servicing, preliminary electrical system checks must be carried out to ensure electrical safety (i.e. polarity, earth continuity, resistance to earth and short circuit).

1.1 REPLACEMENT OF PARTS

The life of individual components varies and they will need servicing or replacing as and when faults develop.

The fault finding sequence chart in chapter 2 will help to locate which component is the cause of any malfunction, and instructions for removal, inspection and replacement of the individual parts are given in the following pages.

1.2 TO GAIN GENERAL ACCESS

All testing and maintenance operations on the boiler require the control panel to be lowered. This will also require the removal of the casing.

1.2.1 Removing the front panel

1. Loosen the fastening screws "A" of the control panel located on the lower part of the panel itself. (FIG. 1.1);

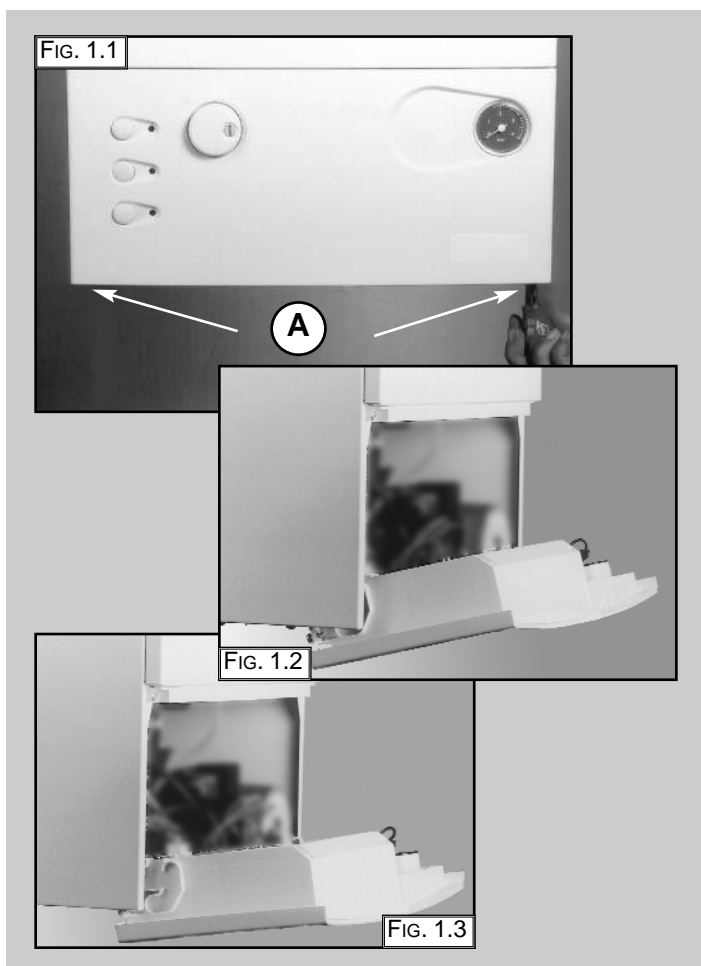

2. The control panel moves downward and when pulled forward, rotates on two lateral hinges; the panel stays in a semi-horizontal position, which allows access to the inner parts of the boiler (FIG. 1.2);
3. In order to increase the manouvering space, it is possible to raise the control panel and rotate it to a fully horizontal position (FIG. 1.3);
4. Remove the screws "B" from the front panel bottom lip (FIG. 1.4);
5. Lift the front panel up and forward from the raised screws at the the top of the casing (FIG. 1.5).

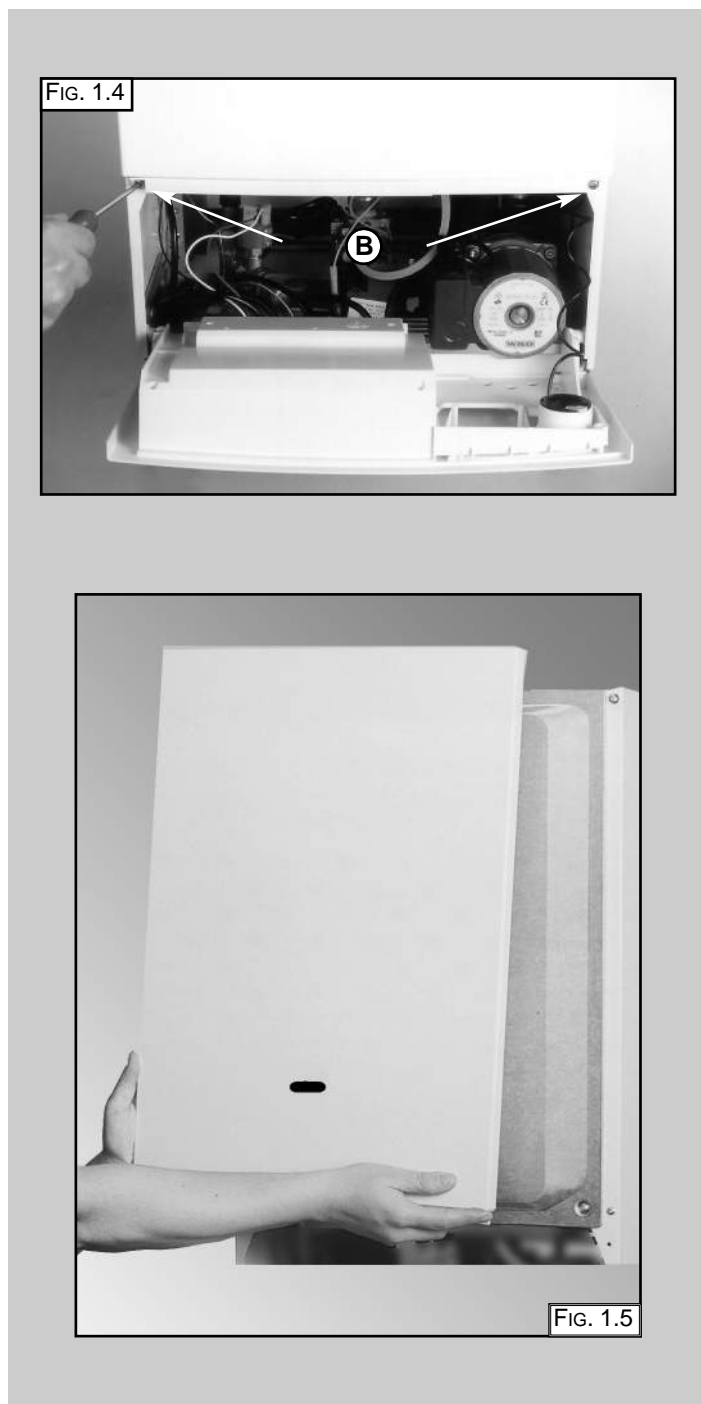

1.2.2 Removing the sealed chamber front cover

1. Remove the screws "C" (FIG. 1.6);
2. Lift the sealed chamber front cover from the locating pins (FIG. 1.7).

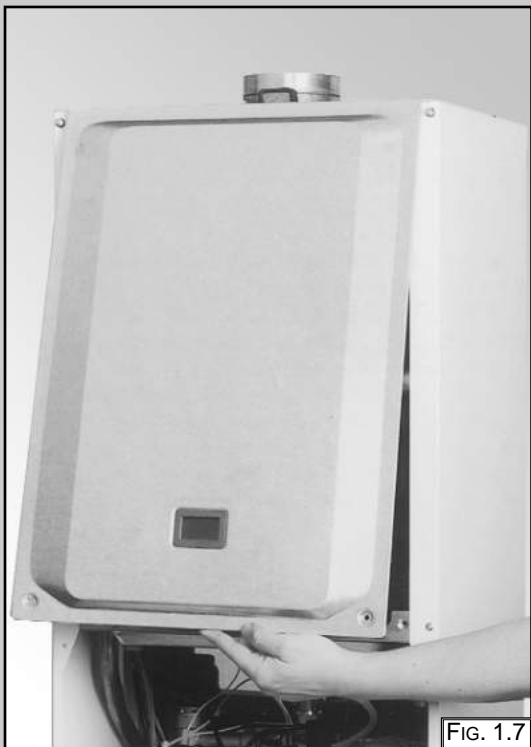
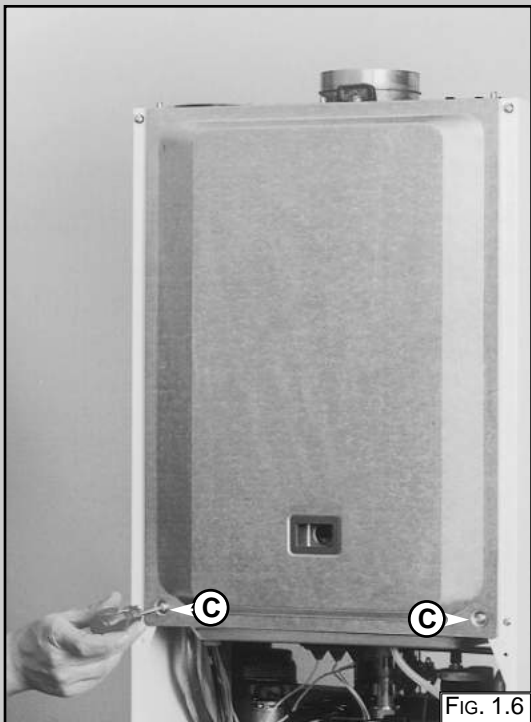

1.2.3 Removing the side panels

1. Remove the four screws "D" for each side panel (FIG.1.8);
2. Pull the panel away from the boiler at the base, then lift the panel up and remove from the boiler.



1.3 ACCESS TO THE COMBUSTION CHAMBER

1.3.1 Removing the combustion cover

1. Remove the screws "E" (FIG. 1.9);
2. Lift off the combustion cover.

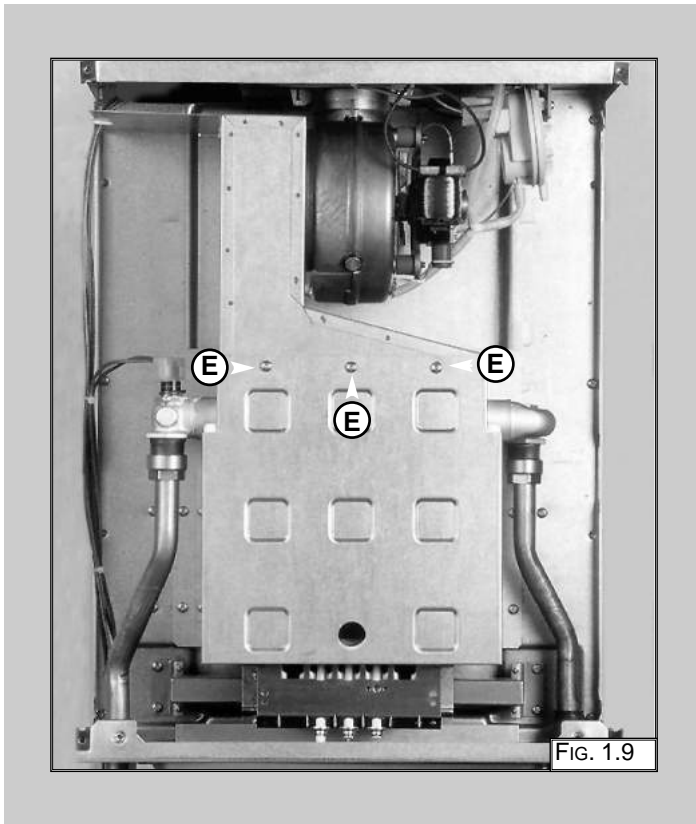

1.3.2 Removing the burner and jets

1. Remove the screws "F" from the burner (FIG. 1.10);
2. Remove the burner (FIG. 1.11);
3. Disconnect the electrodes (see section 1.3.3);
4. Remove the jets using a No. 7 socket spanner;
5. Replace in reverse order.

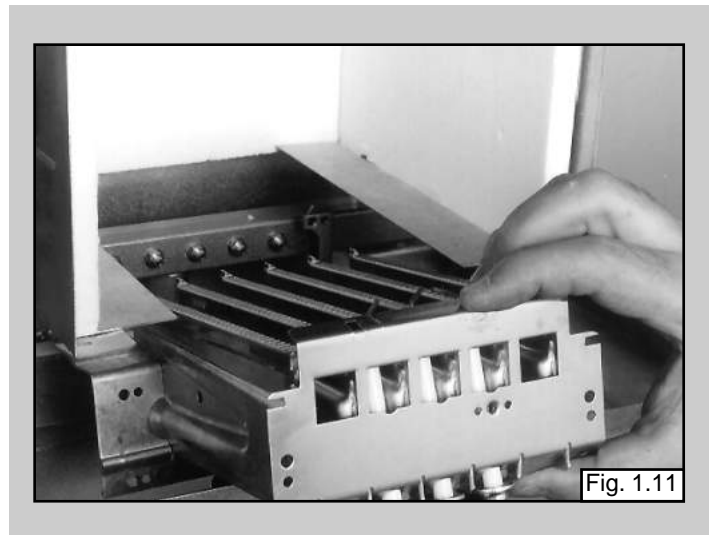
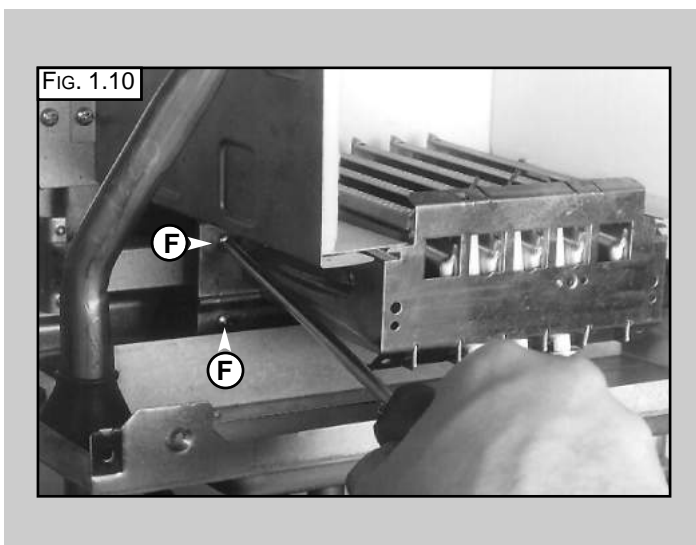

1.3.3 Removing the electrodes

Before carrying out this procedure, unscrew and slide the burner forward (see previous section).

1. Remove rubber gasket "G" (FIG. 1.12);
2. To remove the detection electrode disconnect the cable at its connection point close to the P.C.B. (FIG. 1.13);

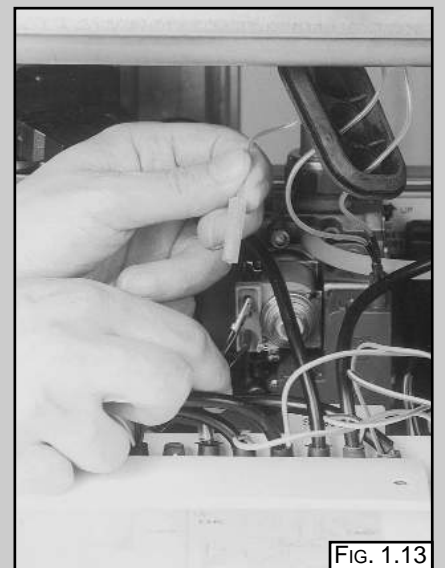
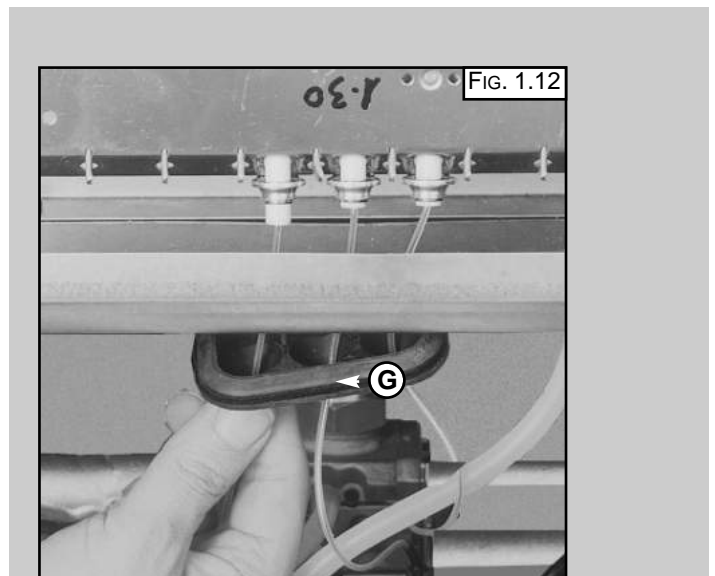

3. Remove screw "H" (FIG. 1.14);
4. Gently slide the electrode downward (FIG. 1.15).

FIG. 1.14

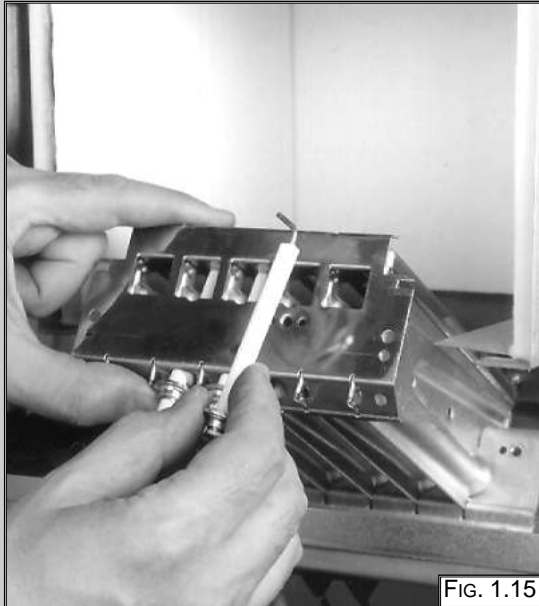
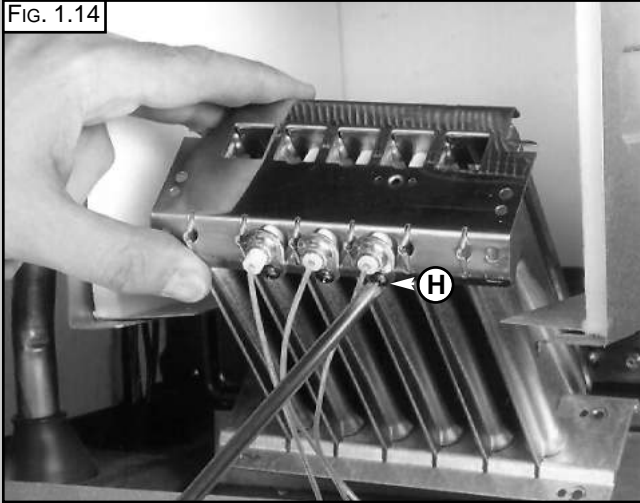

FIG. 1.15

To replace, repeat the steps in reverse order, paying particular attention to the following:

- a** - Centre the electrode in the positioning hole carefully, otherwise the electrode may break;
- b** - Ensure that the left hand and right hand electrodes are located the correct way round (facing each other), to give the correct spark gap;
- c** - Check that the cables have been connected correctly;
- d** - Check that the rubber gasket covers the cable/ electrode connection point completely.

1.3.4 Removing the main heat exchanger

1. Drain the boiler of water;
2. Release the overheat thermostat sensor "I" (FIG. 1.16);
3. Release the two connection nuts "J" connecting the exchanger to the flow and return pipes (FIG. 1.17);
4. Remove the heat exchanger by sliding forward (FIG. 1.18).

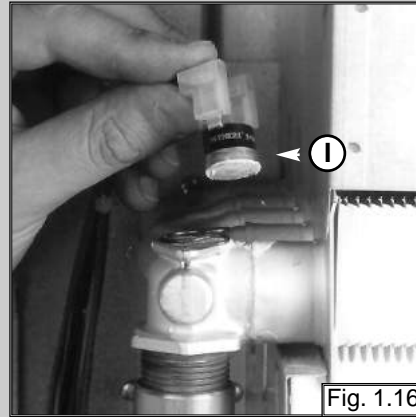

Fig. 1.16

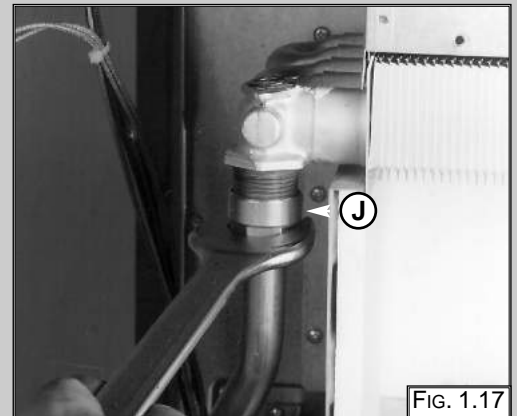

FIG. 1.17

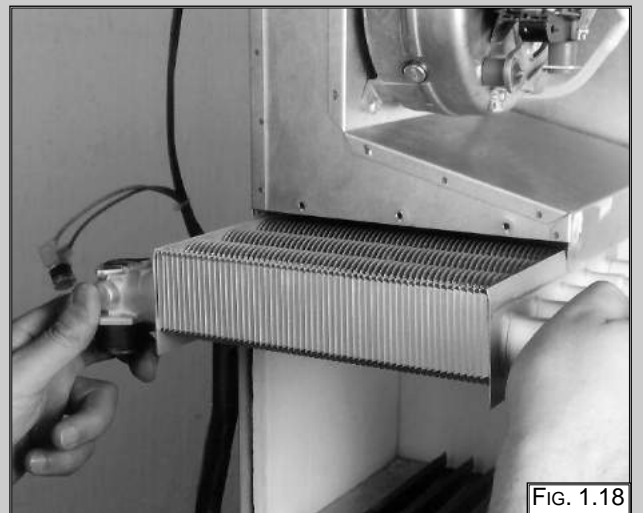
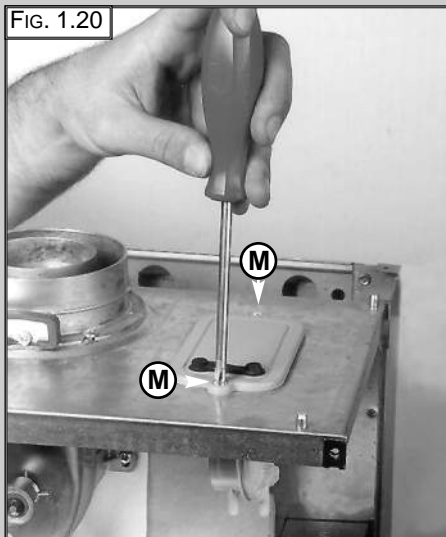
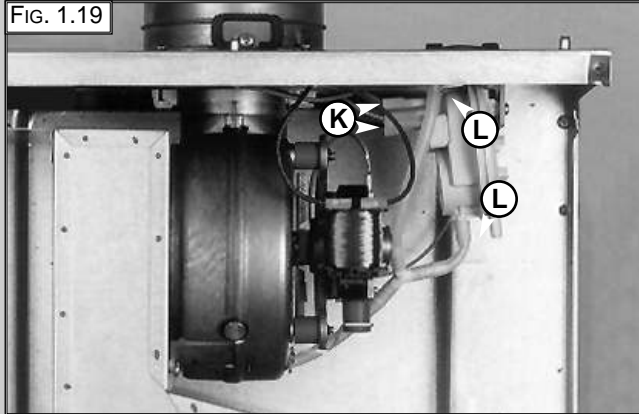

FIG. 1.18

1.3.5 Removing the air pressure switch

1. Disconnect the electrical connections "K" and silicone pipes "L" from their connection points (FIG. 1.19);
2. Remove screws "M" on the top of the sealed chamber (FIG. 1.20);
3. Lift out the air pressure switch (FIG. 1.21);
4. Unscrew to remove the switch from the plate.



1.3.6 Removing the fan

1. Disconnect electrical connections "N" and silicon pipe "O" (FIG.1.22);
2. Remove screw "P" and remove the fan collar clamp "Q" (FIG.1.23);
3. Remove screws "R" (FIG.1.24);
4. Remove fan and mounting plate (FIG.1.25).

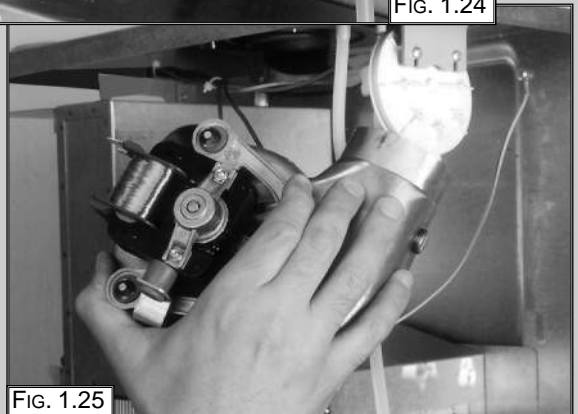
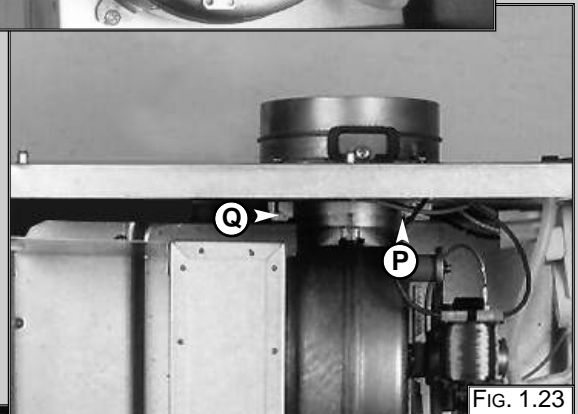
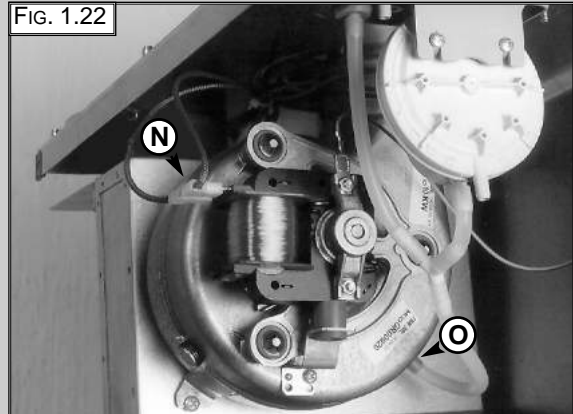

1.4 SERVICING AND REMOVAL OF THE GAS VALVE

1.4.1 Setting the gas pressures

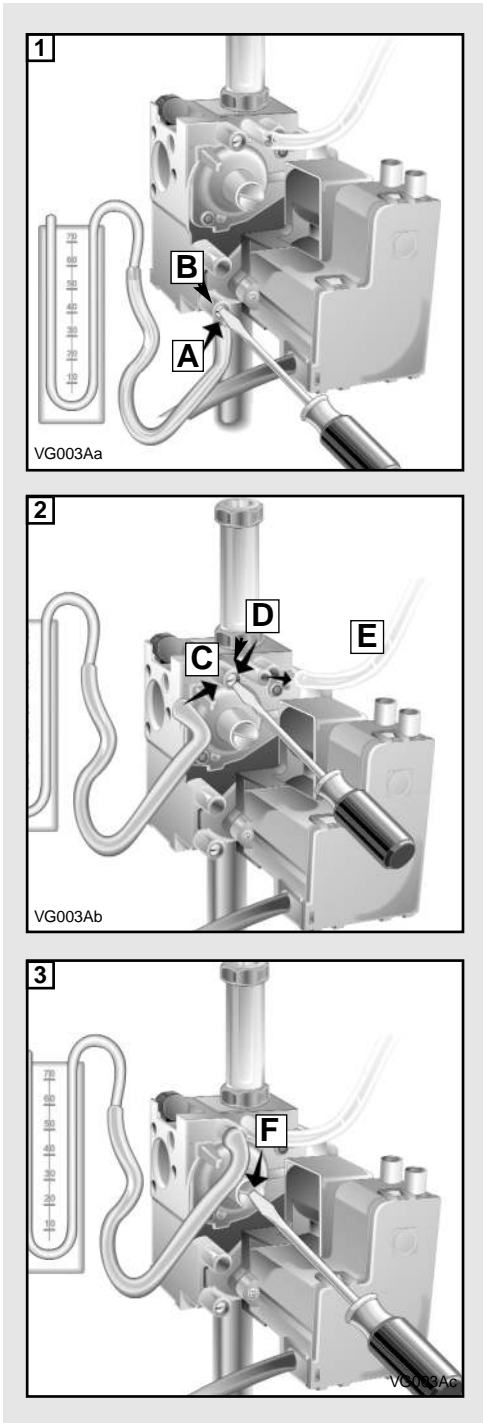

Setting the maximum power of the boiler

1. Check that the supply pressure to the gas valve is a minimum of 20 mbar for natural gas. **Turn off the gas supply at the isolation point under the boiler**
2. To do this, slacken the screw "A".
Fit the pipe of the pressure gauge to the inlet pressure test point of the gas valve "B".
Turn on the gas supply at the isolation point under the boiler and with the boiler running, read the inlet working pressure on the gauge.
When you have completed this operation, **turn off the gas supply at the isolation point under the boiler**, remove the pressure gauge and tighten the screw "A" securely into its housing to seal off the gas. **Turn on the gas supply at the isolation point under the boiler and test the screw for gas escaping with an approved soap and water solution.**
3. To check the pressure supplied by the gas valve to the burner, with the boiler turned off, slacken the screw "C". Fit the pipe of the pressure gauge to the outlet pressure test point of the gas valve "D".
Disconnect the compensation pipe "E" either from the gas valve or from the sealed chamber.
4. Push the On/Off button to "ON" position -*green light*- and push the Heating button to "ON" position -*green light*-
Turn on the boiler by setting the external controls.
Adjust the 10mm nut "F" to set the gas pressure Turn the nut clockwise to increase and anti clockwise to decrease the pressure until the required pressure is achieved (see **TABLE A** page 9)
5. When you have completed the above operations, turn off the external controls, re-connect the supply terminal to the modureg on the gas valve and replace the cap on the screw of the modureg.

Setting pressure for soft ignition.

The soft light pressure is factory set.

If the ignition is not regular (e.g: not complete burner ignition or ignition noise) check the soft light regulator position.

The soft light pressure will need adjusting as follows:

- Turn off electrical supply;
- referring to picture 4, open the dust cap of the soft light regulator, by unscrewing in clockwise direction the white screw;
- turn the adjustment screw one step in the direction max to increase or in the direction min to decrease the soft light pressure;
- after each adjustment of the regulator, turn on the electrical supply and recheck burner ignition (wait 20 seconds between each cycle to allow the gas valves' internal servo system to reset). When the required level is achieved, close the dust cap.

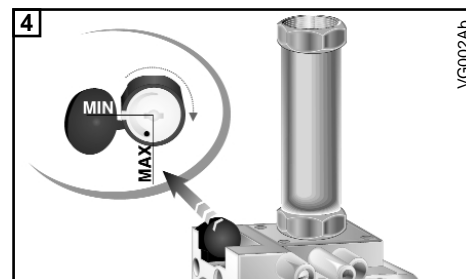

6. Remove the pipe from the pressure gauge and connect screw "C" to the pressure outlet in order to seal off the gas.
7. Carefully check the pressure outlets for gas leaks (valve inlet and outlet).

IMPORTANT!

Whenever you disassemble and reassemble the gas connections, always check for leaks using an approved soap and water solution.

TABLE A

10 RFFI mic SYSTEM		GAS REQUIREMENTS	NATURAL GAS (G20)	BUTANE GAS (G30)	PROPANE GAS (G31)
		Gas rate	max	1.22 m ³ /h	0.91 Kg/h
Gas rate	min	----- m ³ /h	----- Kg/h	----- Kg/h	
Gas restrictor	ι	-----	2.9	2.9	
Inlet pressure		20 mbar	28 mbar	37 mbar	
Burner pressure max		8.3 mbar	22.9 mbar	29.5 mbar	
Burner pressure min		---- mbar	---- mbar	---- mbar	
Burner jets		6 x 1.30	6 x 0.77	6 x 0.77	

TB016A

1.4.2 Removing the spark generator

1. Disconnect ignition leads "S" by pulling upward (FIG. 1.26);
2. Remove the screw "T" (FIG. 1.27);
3. Remove the spark generator by pulling forward from the gas valve.

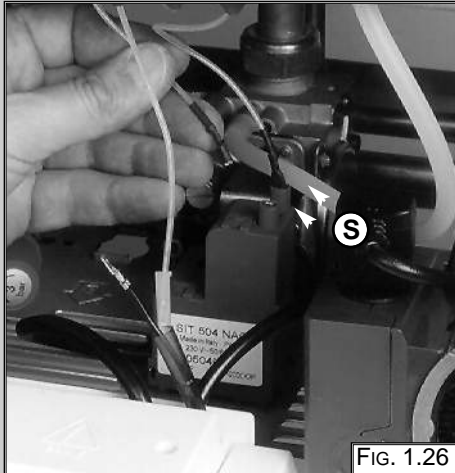

FIG. 1.26



FIG. 1.27

1.4.3 Removing the gas valve

Important! Before removing the gas valve, ensure the gas supply is turned off.

1. Disconnect all the cables from the solenoid and modureg;
2. Remove the spark generator (see previous section);
3. Release the top nut "U" (FIG. 1.28);
4. Remove the screws "V" from the bottom of the gas valve pipe (FIG. 1.29);
5. Remove the gas valve).

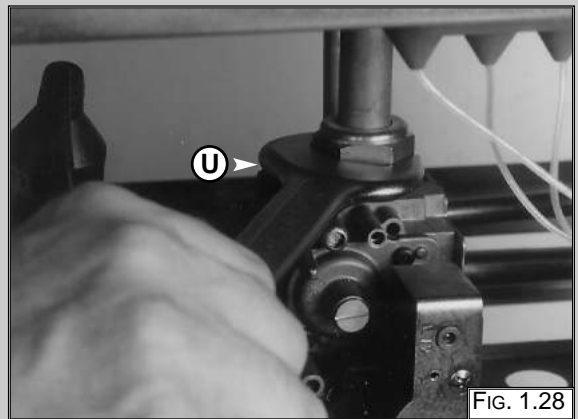

FIG. 1.28

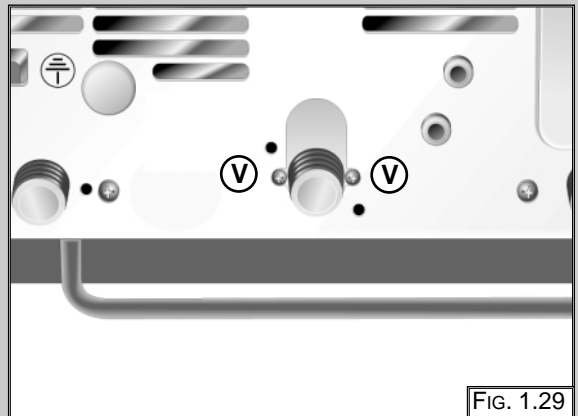

FIG. 1.29

1.5 ACCESS TO THE WATER CIRCUIT

Important! Before any component is removed, the boiler must be drained of all water.

1.5.1 Removing the pump pressure switch

1. Remove the cable of the pump pressure switch "W" (Fig. 1.31);
2. Unscrew the pump pressure switch by using a spanner on the nut "X"(Fig. 1.32);
3. Remove the pump pressure switch.

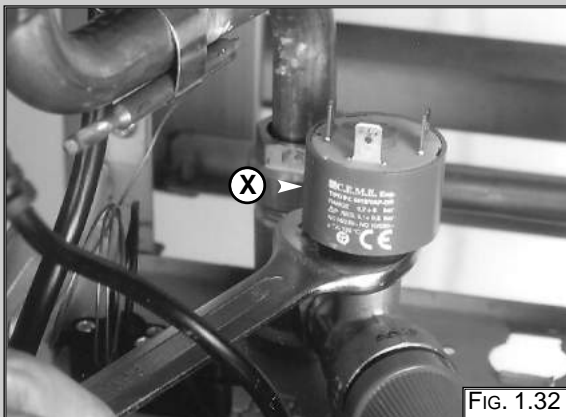

1.5.2 Removing the safety valve

1. Loosen nut "Y" (Fig. 1.33);
2. Disconnect the discharge pipe work from below the boiler;
3. Unscrew and remove the valve.

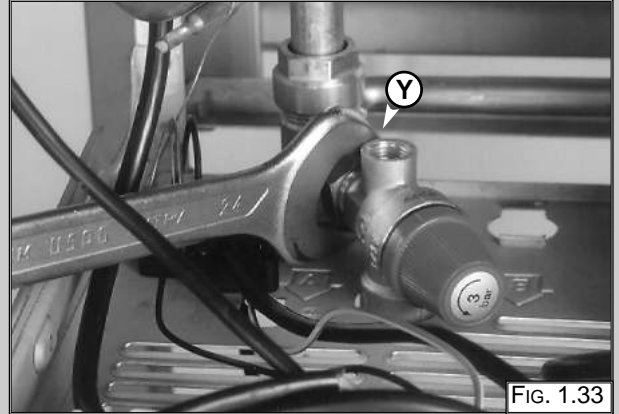

1.5.3 Removing the automatic air vent

1. Unscrew valve top "Z" (Fig. 1.34);
2. Remove valve complete with float (Fig 1.35).

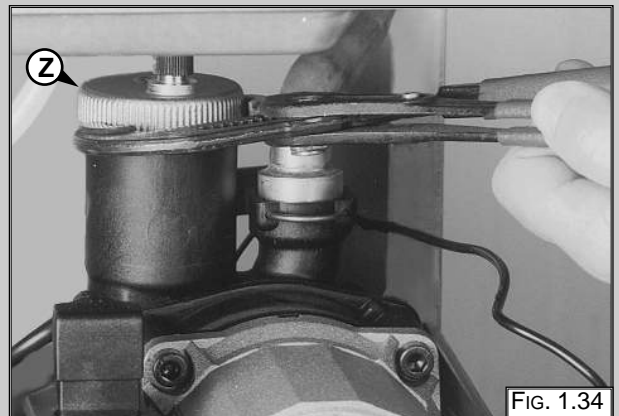

1.5.4 Removing the pump

1. Remove the U-clips "A1" and "B1" (FIG. 1.36);
2. Remove the retaining clip "C1" (FIG. 1.37);
3. Release the nut "D1" (FIG. 1.38);
4. Remove the pipe "E1" (FIG. 1.39);
5. Remove the screw "F1" (FIG. 1.40);
6. Remove the pump (FIG. 1.41).

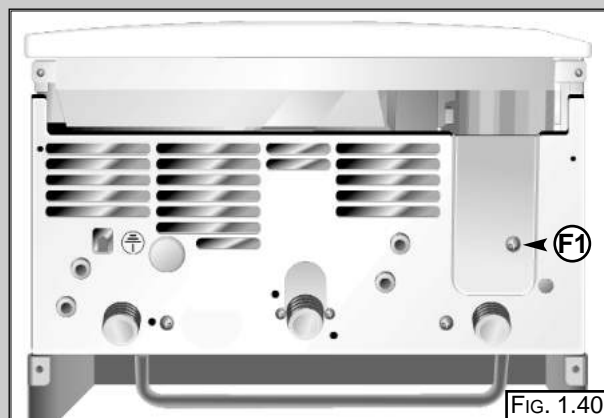
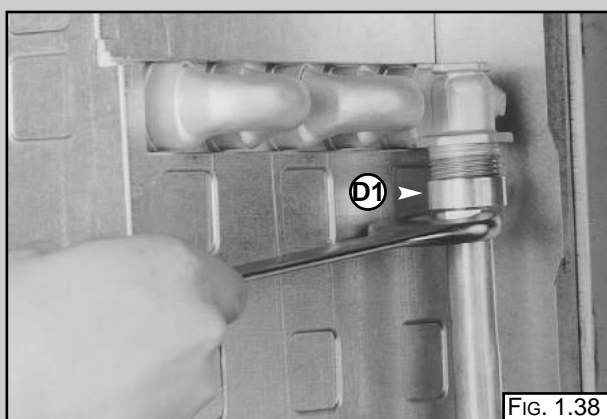
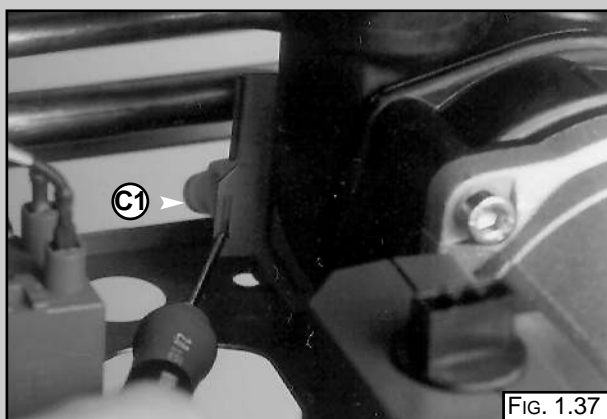
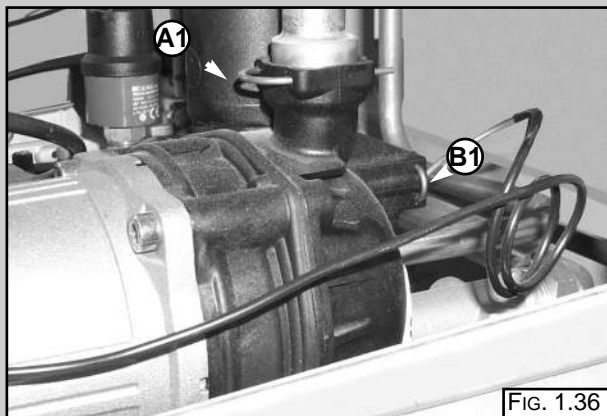

1.5.5 Removing the pressure gauge

1. Remove the U-clip "G1" and remove the pressure gauge coupling (FIG. 1.42);
2. Push the pressure gauge through the control panel from the rear (FIG. 1.43).

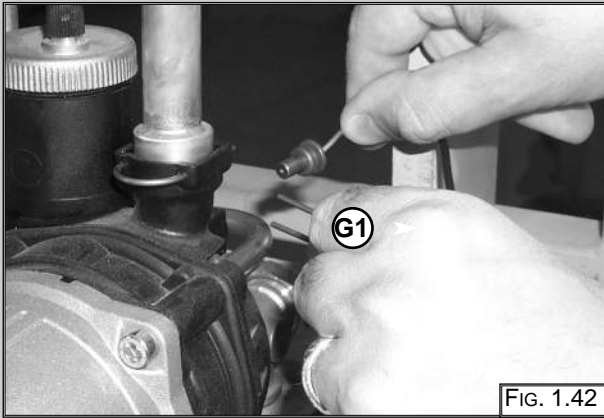

1.5.6 Removing the expansion vessel

1. Release nuts "H1" and remove the gas pipe (FIG. 1.44);
2. Release nut "I1" (FIG. 1.45);
3. Remove lock-nut "J1" (FIG. 1.46);
4. Remove the expansion vessel (FIG. 1.47).

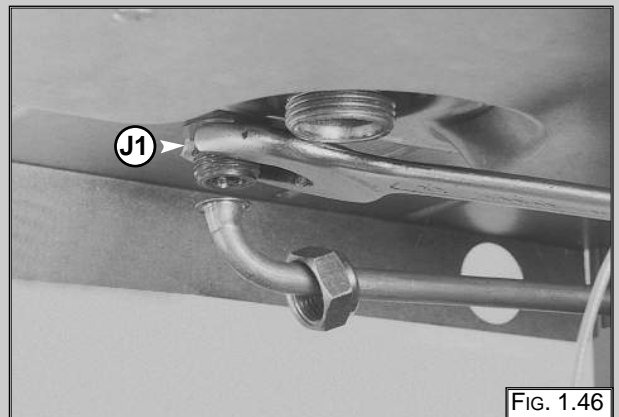
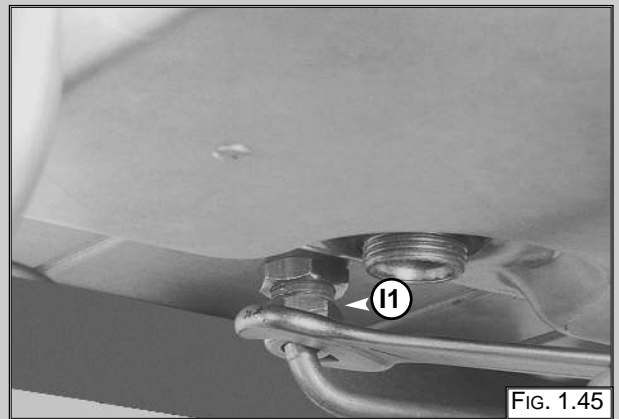
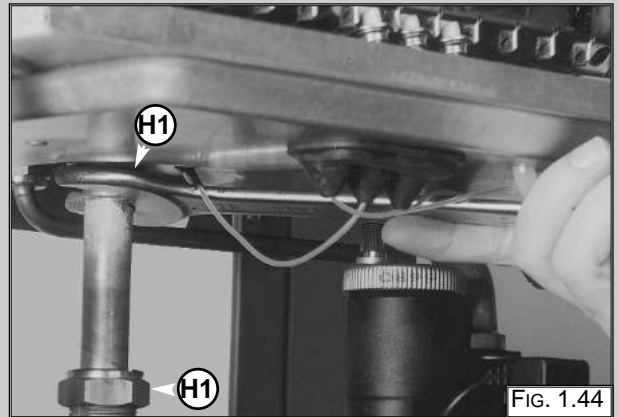

1.5.6 Removing the overheat thermostat

1. Disconnect the overheat thermostat electrical connections "K1" (FIG. 1.48);
2. Then remove the thermostat from its mounting by releasing the securing clip (FIG. 1.49).

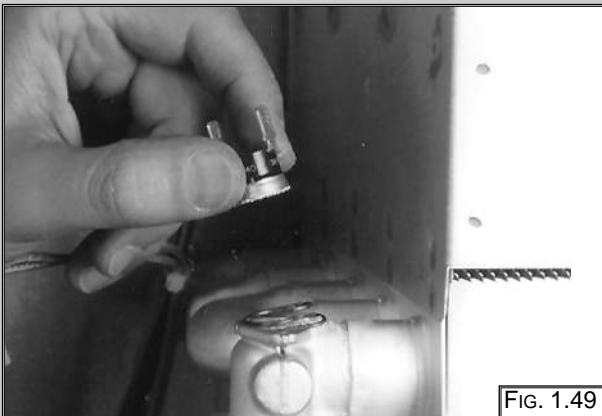
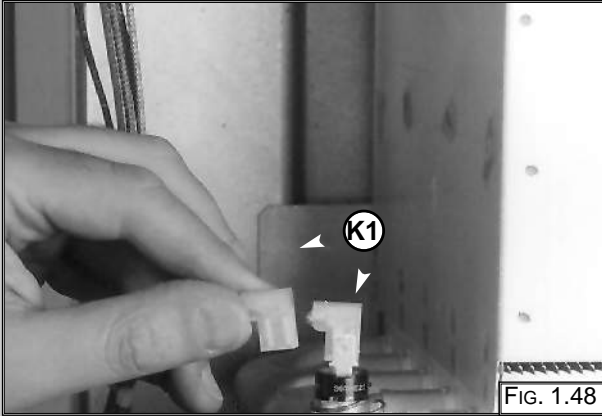

1.5.7 Removing the frost thermostat

1. Disconnect the frost thermostat electrical connection "L1" (FIG. 1.50);
2. Then remove the thermostat from its mounting by releasing the securing clip (FIG. 1.51).

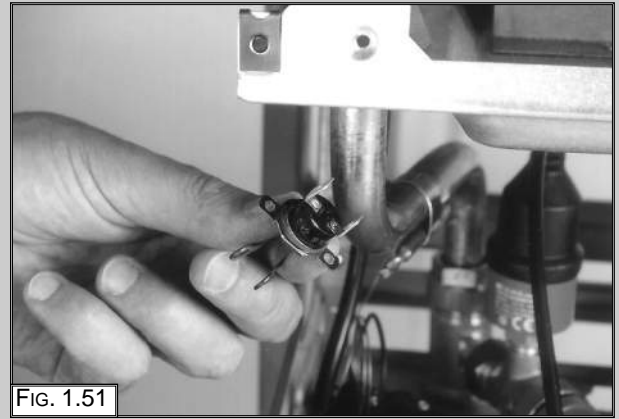
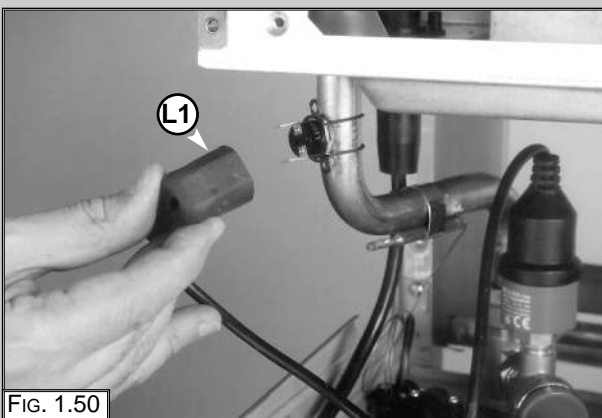

1.5.8 Removing the regulation thermostat

1. Remove the regulation thermostat sensor from its mounting by releasing the securing clip "M1" (FIG. 1.52);
2. Separate the fascia panel from the rear of the control panel (see section 1.6.2);
3. Remove the electrical connections "N1" from the regulation thermostat (FIG. 1.53);
4. Pull the regulation knob from the spindle of the thermostat;
5. Remove the thermostat from the control panel fascia by unscrewing the mounting screws.

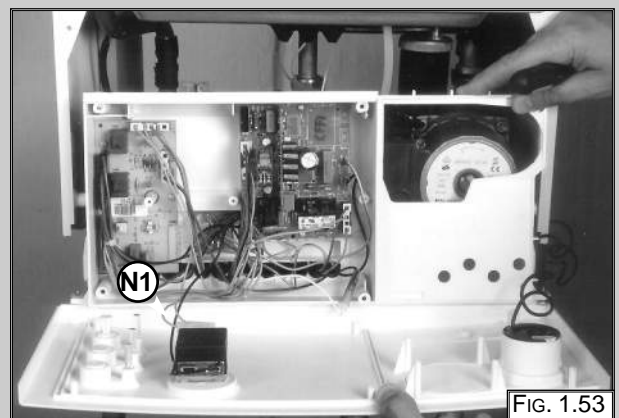
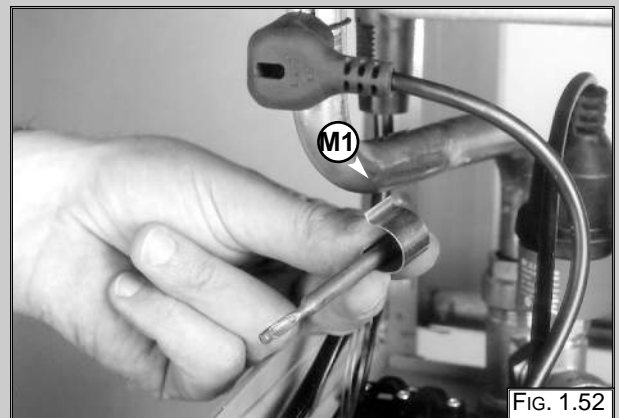

1.6 ACCESS TO THE CONTROL SYSTEM

Important! Isolate the electrical supply to the boiler before accessing the control panel.

1.6.1 Checking the fuse

1. Remove the inspection cover on the reverse of the control panel (FIG. 1.54);
2. Remove the fuse mounted on the reverse of the inspection cover (FIG. 1.55).

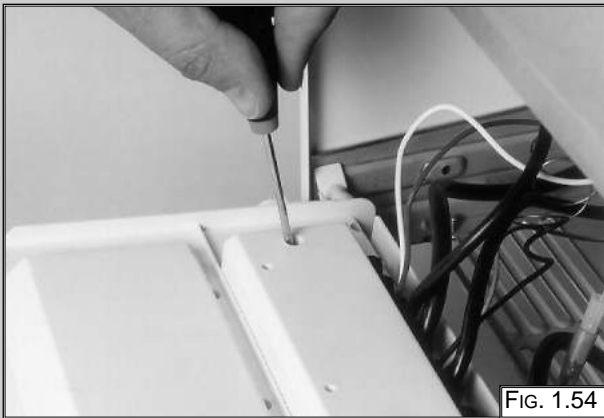

FIG. 1.54

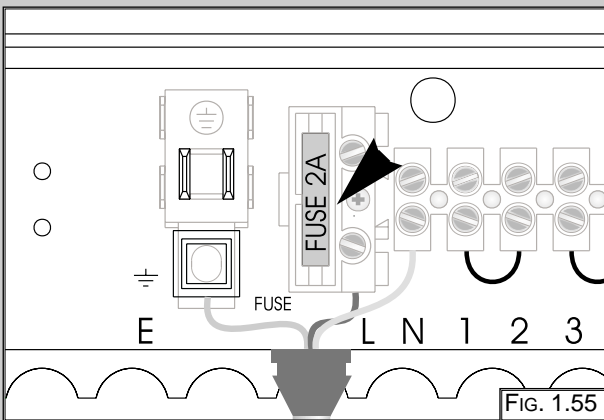

FIG. 1.55

1.6.2 Removing the P.C.B.s

1. Isolate electricity;
2. Remove the screws "O1" (FIG. 1.56);
3. Separate the facia panel from the rear of the control panel;
4. Unplug all electrical connections from the P.C.B. and remove the screws "P1" and remove the P.C.B. (FIG. 1.57).

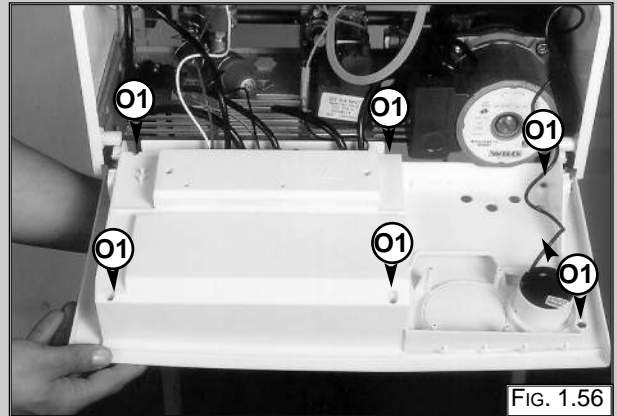

FIG. 1.56

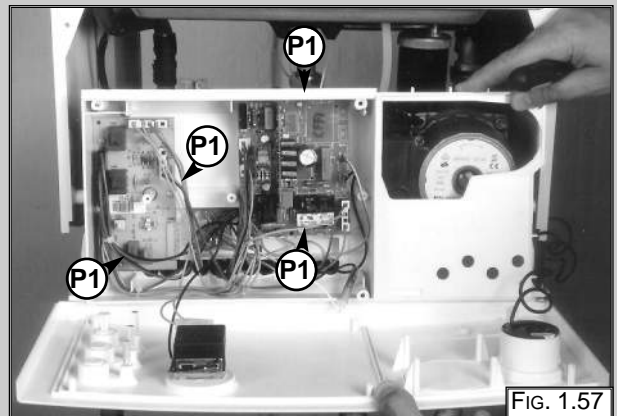
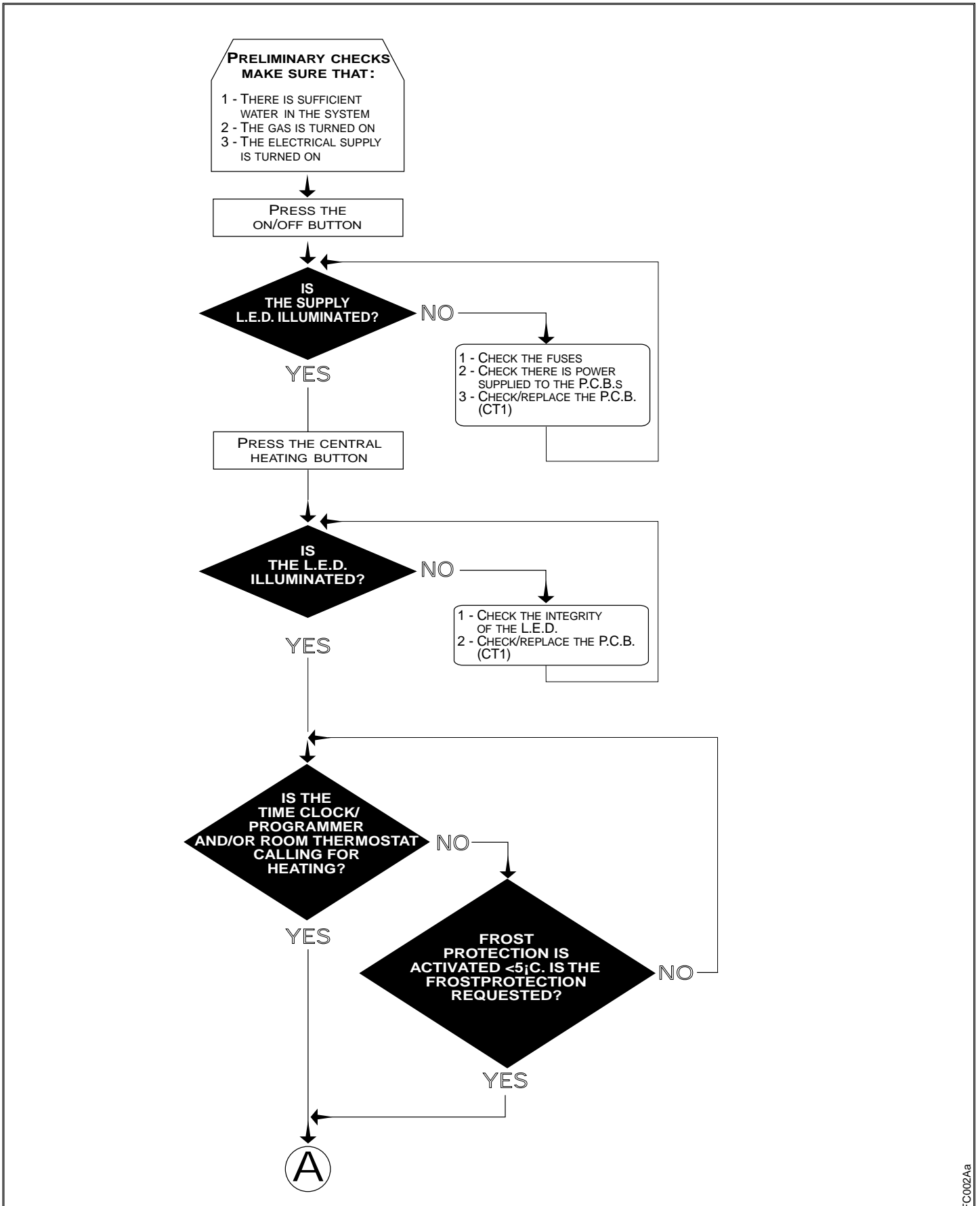

FIG. 1.57

2. FAULT FINDING

2.1 FAULT FINDING GUIDE (FLOW-CHARTS)

It is possible to detect and correct any defect by using the standard fault finding diagrams described in this chapter.



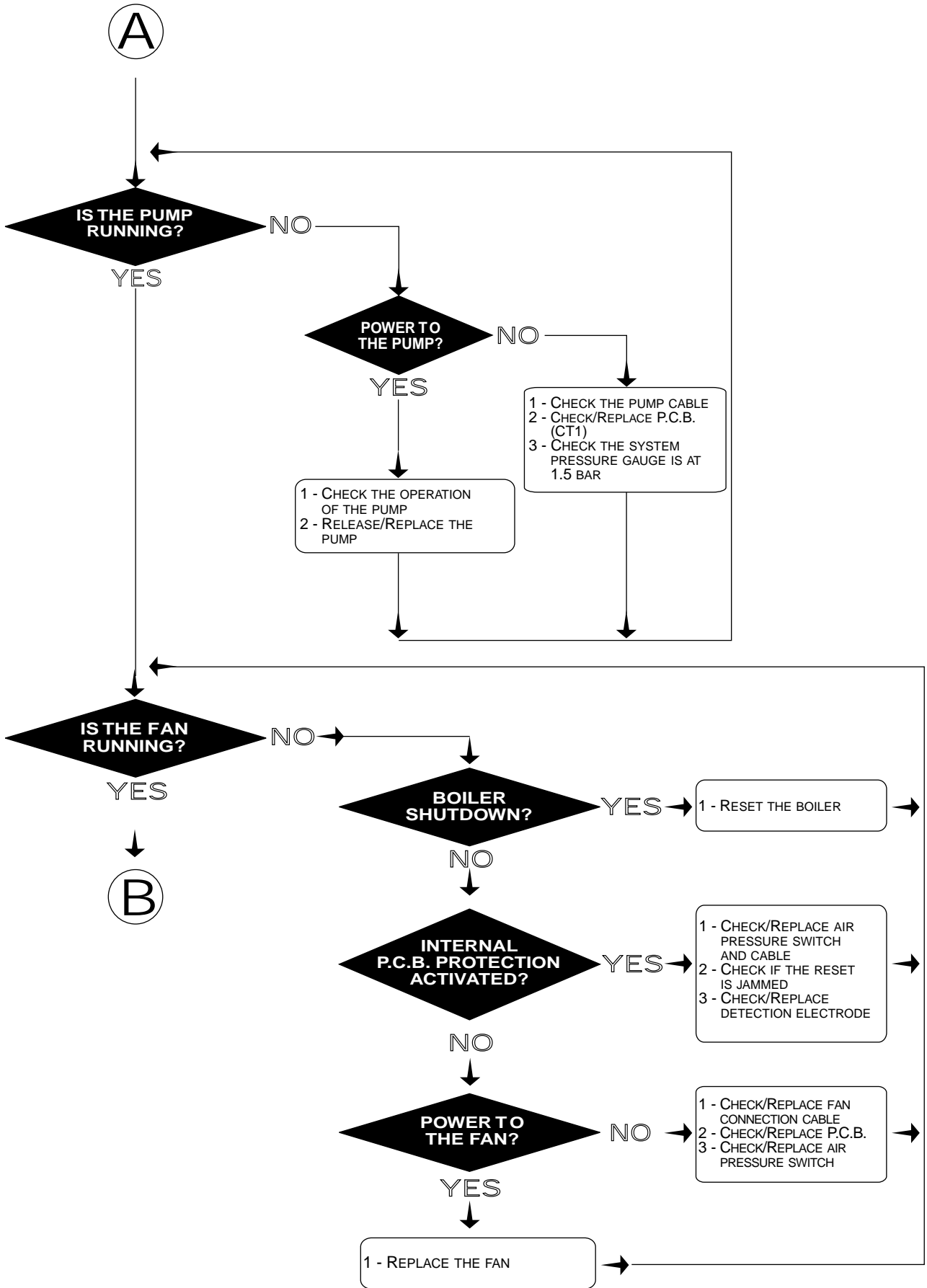

(B)

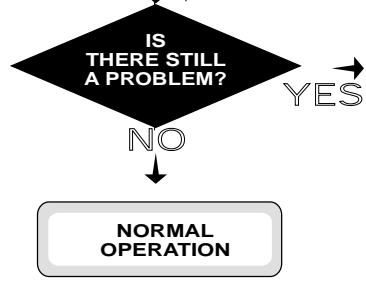
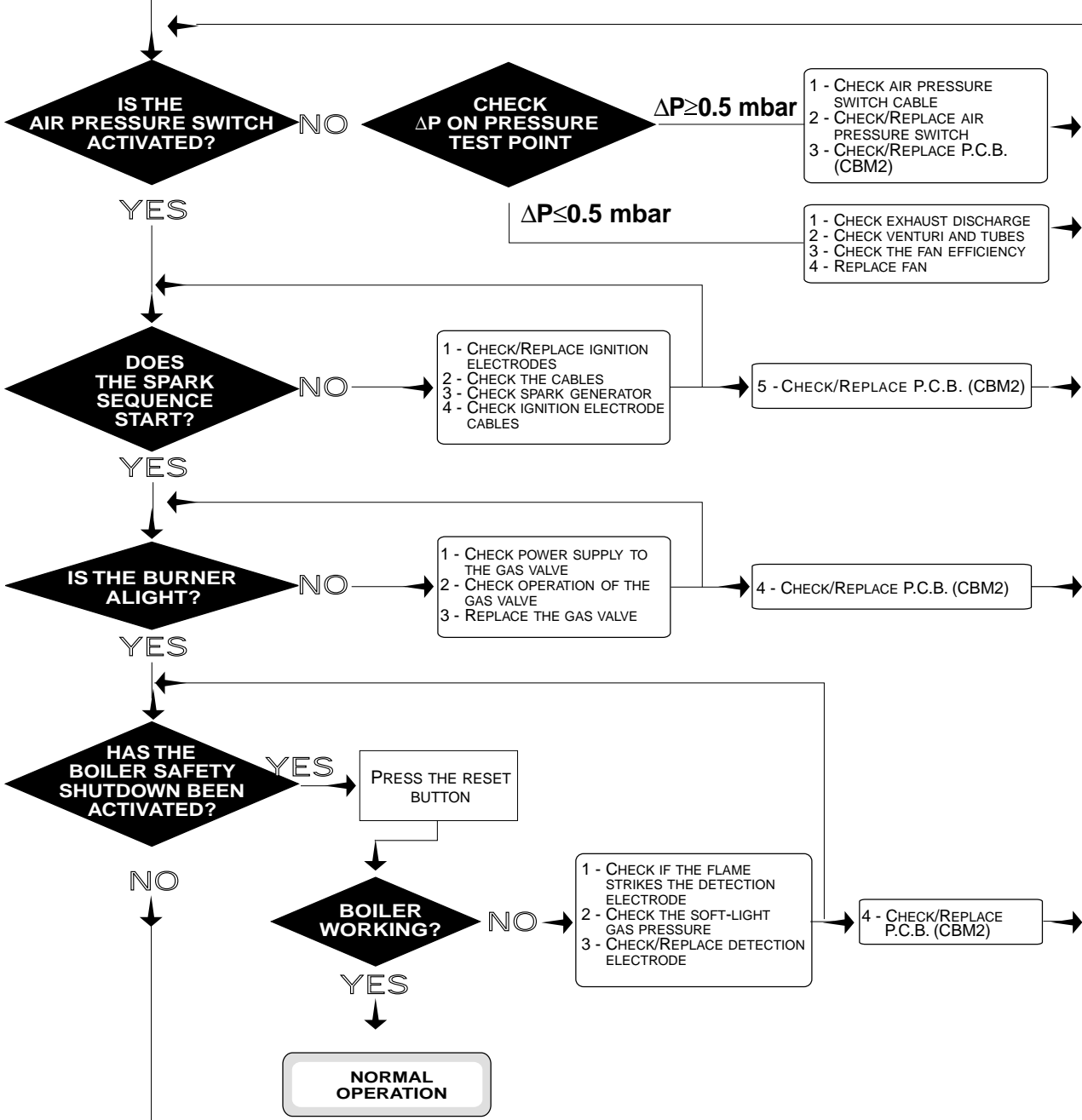

	<i>FAULT LIST</i>	<i>POSSIBLE CAUSES</i>
1	NOISEY OPERATION	<ul style="list-style-type: none"> - MAIN HEAT EXCHANGER FAULTY OR BLOCKED WITH LIME-SCALE DEPOSITS - LOW HEATING SYSTEM WATER PRESSURE - CHECK GAS PRESSURES - CHECK HEATING THERMOSTAT - CHECK FAN - CHECK PUMP
2	DECREASE/INCREASE OF HEATING CIRCUIT PRESSURE	<ul style="list-style-type: none"> - CHECK FOR LEAKS ON THE HEATING CIRCUIT - FAULTY FILLING LOOP - FAULTY EXPANSION VESSEL
3	REPEATED SHUTDOWNS	<ul style="list-style-type: none"> - FAULTY DETECTION ELECTRODES - CHECK GAS PRESSURES - CHECK FLAME DETECTION ELECTRICAL CIRCUIT
4	REPEATED OPERATION OF SAFETY THERMOSTAT	<ul style="list-style-type: none"> - FAULTY HEATING THERMOSTAT - FAULTY OVERHEAT THERMOSTAT - PRESENCE OF AIR IN THE HEATING CIRCUIT - CHECK BURNER PRESSURES - CHECK EXCHANGER FLUEWAY
5	INSUFFICIENT RADIATOR TEMPERATURE	<ul style="list-style-type: none"> - CHECK HEATING THERMOSTAT - CHECK BY-PASS - CHECK GAS PRESSURE

3. ELECTRICAL DIAGRAMS

LEGEND:

- A - On/Off Switch
- B - On/Off L.E.D.
- C - Heating Switch
- D - Heating L.E.D.
- E - Reset Button
- F - Ignition Failure (Lockout) L.E.D.

- A01 - Pump Pressure Switch
- A02 - Frost Thermostat
- A03 - Modulator
- A04 - Circulation Pump
- A05 - Regulation Thermostat

- A06 - External Control System
- A07 - Time Clock Connector
- A08 - External (Room) Thermostat
- A09 - Air Pressure Switch
- A10 - Fan
- A11 - Overheat Thermostat
- A12 - Spark Generator/Gas Valve Supply
- A13 - Detection Electrode

- Colours:**
- Wh -White
 - Bl -Blue
 - Gry -Grey
 - Brn -Brown
 - Blk -Black
 - Rd -Red
 - Grn/Yll -Yellow/Green

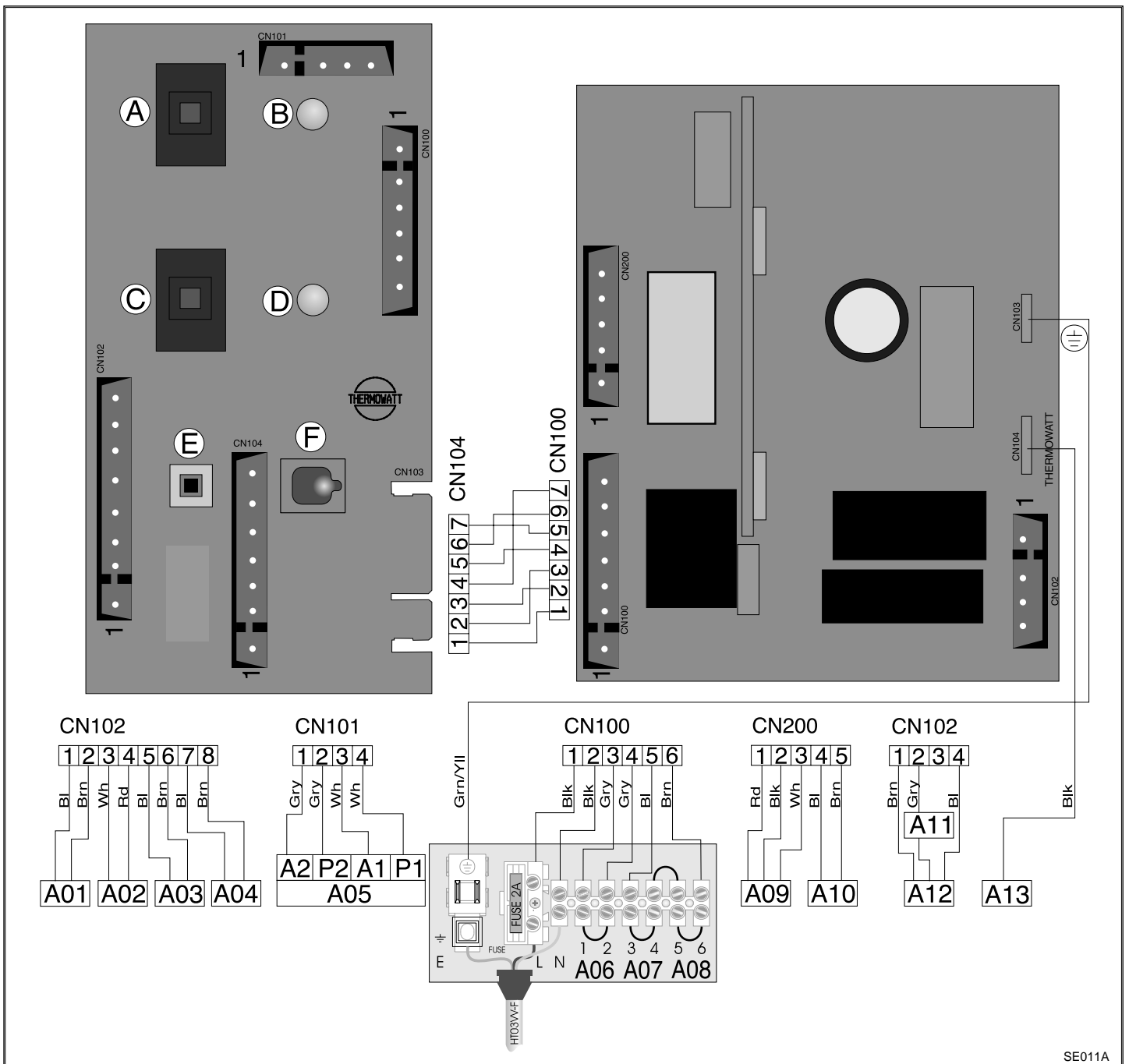

SE011A

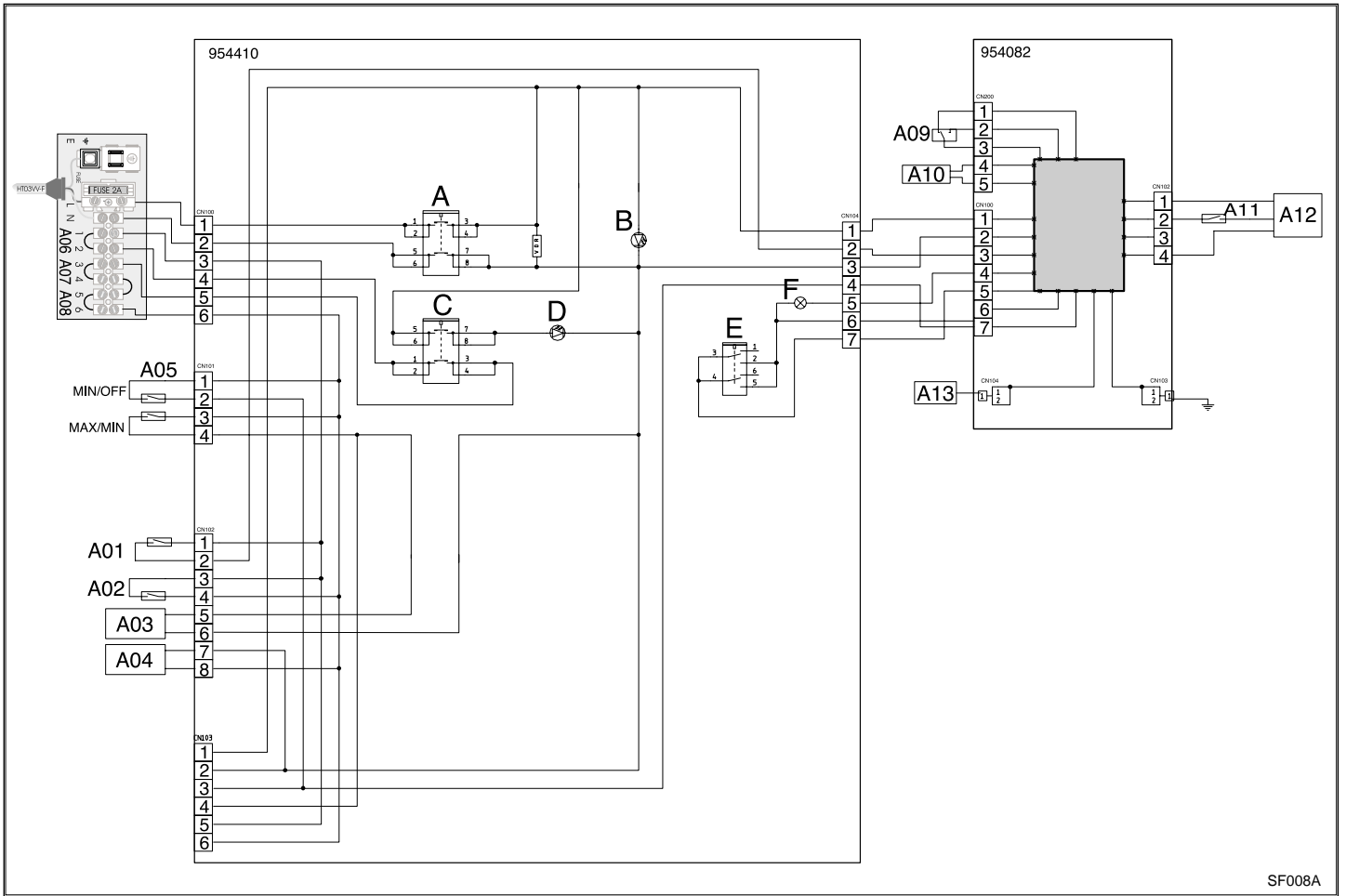

SF008A

4. SHORT SPARE PARTS LIST

microSYSTEM 10 RFFI

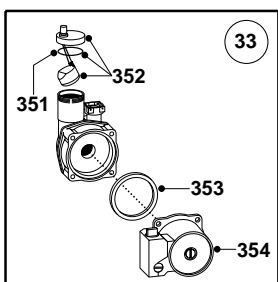
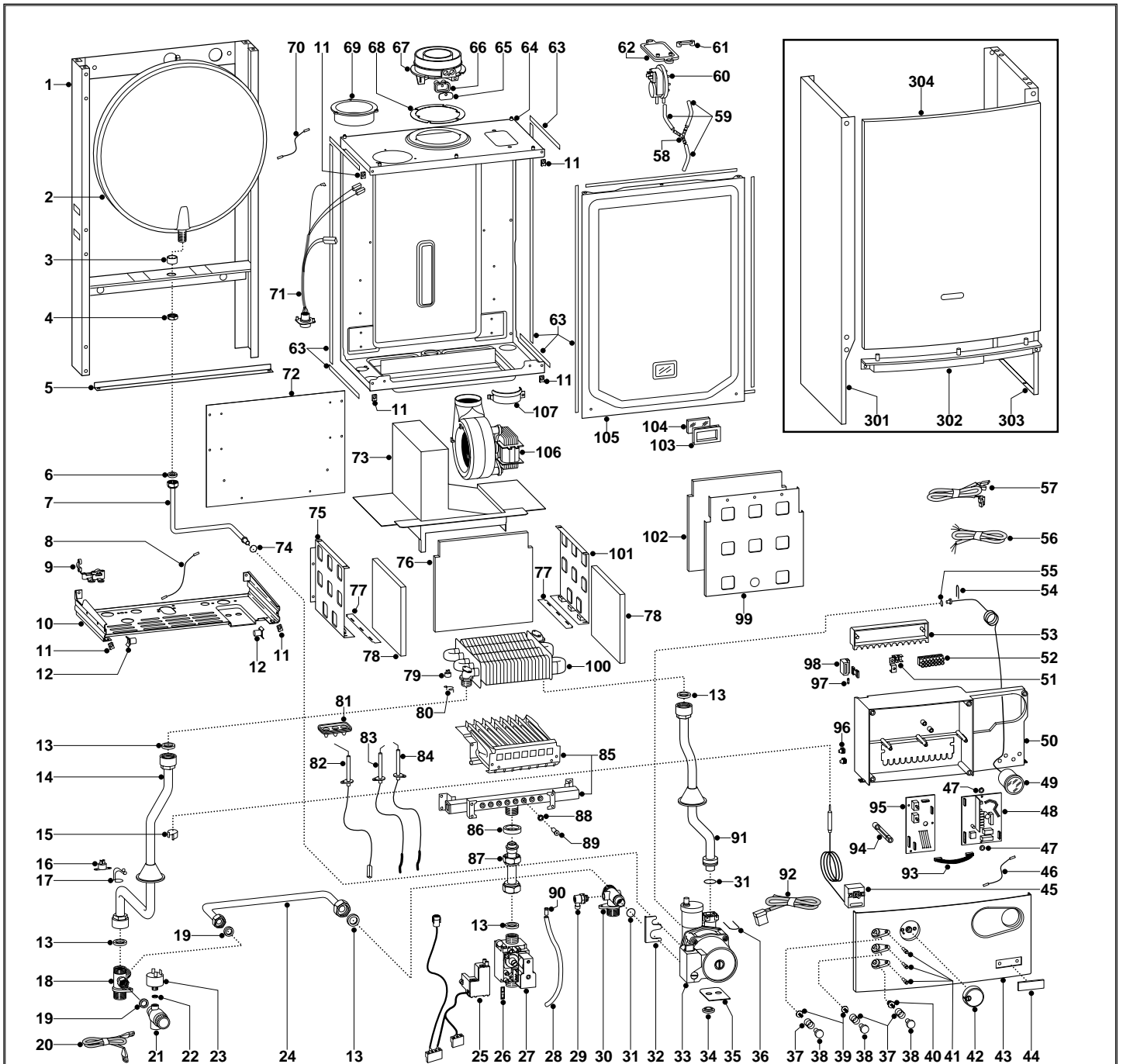

MODELS	CHARACTERISTICS	SERIAL NO: VALIDITY	REF.
MICROSYSTEM 10 RFFI	METHANE	2320021100001	A
MICROSYSTEM 10 RFFI	LPG	2320021100001	B
MICROSYSTEM 15 RFFI	METHANE	2320021100001	C
MICROSYSTEM 15 RFFI	LPG	2320021100001	D

microSYSTEM 10 RFFI

Key no.	G.C. part no.	Description	ARISTON Part No.
2		Expansion vessel	998616
6	164 282	Gasket 3/8"	573521
13	164 225	Gasket 3/4"	573520
16		Thermostat (frost)	570760
18		Flow group	998612
19	164 229	Gasket 1/2"	573528
21		Safety valve (1/4" 3 bar)	998447
22	164 261	Gasket 1/4"	569390
23		Pump pressure switch	998627
25		Spark Generator	999542
26		Gasket	574279
27		Gas valve	999474
29		Auto air vent	998809
30		Return group	999476
31		O-ring	998424
33		Pump	998836
45		Thermostat (regulation)	999578
48		P.C.B. (CBM2 AT-FFI2X)	999499
49		Pressure gauge	999245
55		Gasket	998517
60		Air pressure switch	998484
74		Gasket	997182
79		Thermostat (overheat)	999538
82		Detection electrode	998624
83		Electrode (ignition L.H.)	998622
84		Electrode (ignition R.H.)	998623
78CD		Main exchanger	998893
85A		Burner 6 ramp (natural gas)	999481
85B		Burner 6 ramp (LPG)	999686
85C		Burner 8 ramp (natural gas)	999479
85D		Burner 8 ramp (LPG)	999685
89AC		Burner jet (natural gas 1.30)	998433
89BD		Burner jet (LPG 0.77)	998434
95		P.C.B. (CT1)	999501
97		Fast fuse 2AT	950030
100		Main exchanger	999486
106AB		Fan	998487
106CD		Fan	998488
351		O-ring (A.A.V.)	998644
352		Auto air vent	998643
353		Gasket (pump head)	998738
354		Pump head	998961
361	E24 076	Burner jet 1.30 full kit (natural gas)	998716
362	E24 075	Burner jet 0.77 full kit (LPG)	998717

Manufacturer: **Merloni TermoSanitari SpA - Italy**

Commercial subsidiary: **MTS (GB) LIMITED**

MTS Building
Hughenden Avenue
High Wycombe
Bucks HP13 5FT

Telephone: (01494) 755600

Fax: (01494) 459775

Internet: <http://www.mtsgb.ltd.uk>

E-mail: info@mtsgb.ltd.uk

Technical Service Hot Line: (01494) 539579