

BAXI

User's Operating Instructions & Important Warranty Information

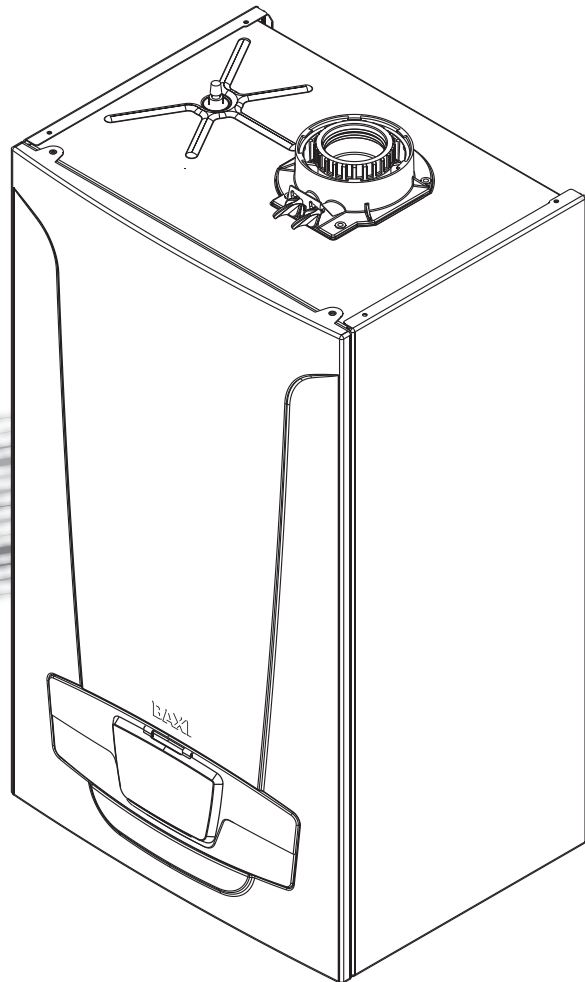

Duo-tec 2 Combi Range

Gas Fired Wall Mounted Condensing
Combination Boiler

Please keep these instructions in a safe place.
If you move house, please hand them over to the next occupier.

Model Range

Baxi Duo-tec 2 Combi 24
G.C. No. 47-075-67

Baxi Duo-tec 2 Combi 28
G.C. No. 47-075-68

Baxi Duo-tec 2 Combi 40
G.C. No. 47-075-40

Contents

Section	Page
1.0 Quick Reference Guide	3
2.0 Troubleshooting	4
3.0 Temperature Adjustment & Care of the Boiler	6
4.0 Repressurising System & 'Service Due'	7
5.0 Clearances	8
6.0 Error Codes	9
7.0 Legislation	10
8.0 Emergency	11
9.0 Warranty & Service	Back page

The Benchmark Scheme

Baxi Heating UK Ltd is a licensed member of the Benchmark Scheme which aims to improve the standards of installation and commissioning of domestic heating and hot water systems in the UK and to encourage regular servicing to optimise safety, efficiency and performance.

Benchmark is managed and promoted by the Heating and Hotwater Industry Council. For more information visit www.centralheating.co.uk

© Baxi Heating UK Ltd 2013 All rights reserved. No part of this publication may be reproduced or transmitted in any form or by any means, or stored in any retrieval system of any nature (including in any database), in each case whether electronic, mechanical, recording or otherwise, without the prior written permission of the copyright owner, except for permitted fair dealing under Copyrights, Designs and Patents Act 1988.

Applications for the copyright owner's permission to reproduce or make other use of any part of this publication should be made, giving details of the proposed use, to the following address:

The Company Secretary, Baxi Heating UK Limited,
Brooks House, Coventry Road, Warwick. CV34 4LL

Full acknowledgement of author and source must be given.

WARNING: Any person who does any unauthorised act in relation to a copyright work may be liable to criminal prosecution and civil claims for damages.

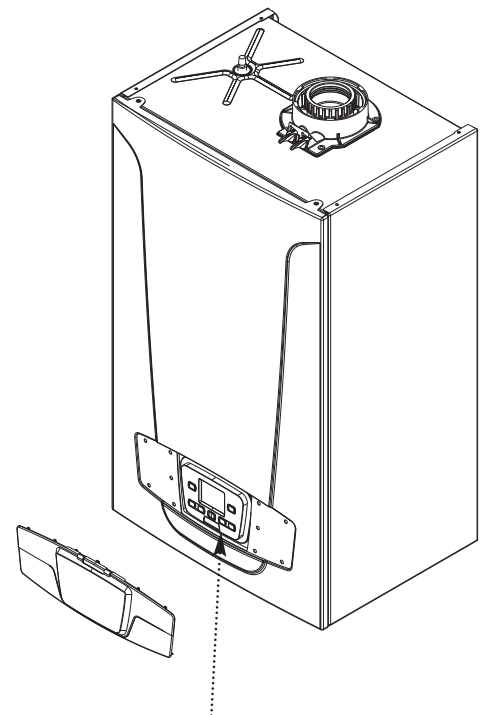

Boiler Controls - see opposite page for Operating Quick Reference Guide (Fascia Cover removed for clarity)

IPX5D

CE 0086



WRAS APPROVED PRODUCT



ISO 9001
FM 00866

I.0 Quick Reference Guide

Key to Controls

 Standby - Reset - Esc Button

 Boiler Information View Button

 Increase Central Heating Temperature Button

 Decrease Central Heating Temperature Button

 Increase Domestic Hot Water Temperature Button

 Decrease Domestic Hot Water Temperature Button

 Summer / Winter / Heating Only Mode Button

 Summer - Domestic Hot Water only mode

 Winter - Domestic Hot Water & Central Heating mode

 Heating Only - Only Central Heating mode

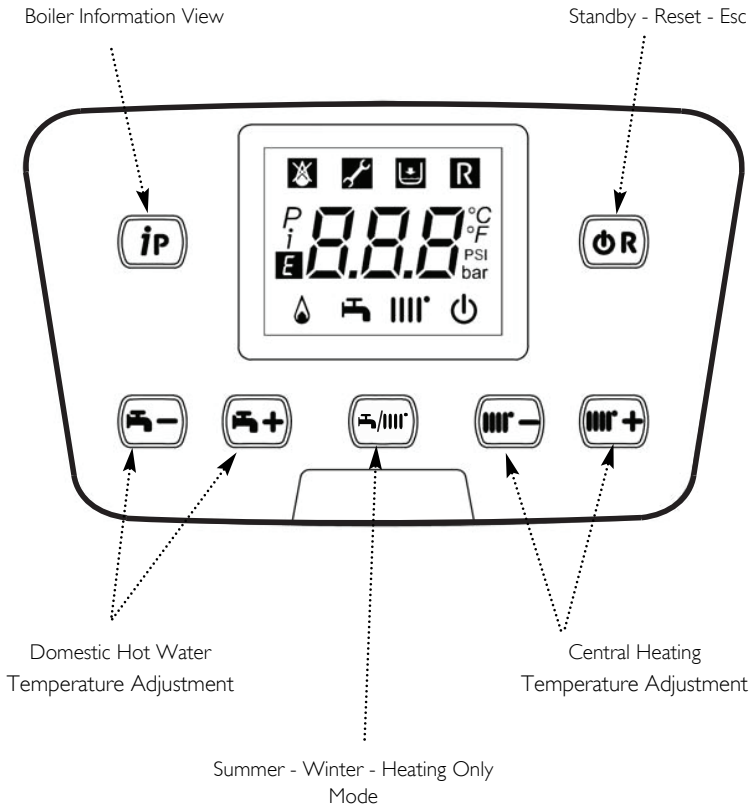

NOTE: When altering any settings it is necessary that the buttons are pressed firmly.

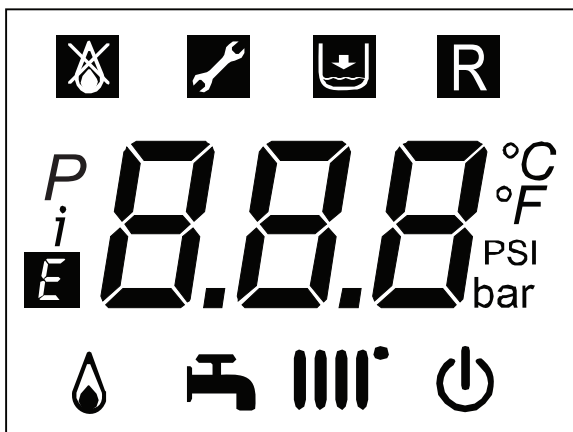

Display showing all available characters

Display Description

 Domestic Hot Water and Central Heating OFF (frost protection still enabled)

 Error

 Indicates errors that prevent burner from igniting

 Error - Not resettable by user

 Water pressure too low

 Indicates an error resettable by the user

P Indicates navigation in programming mode (parameter)

i Indicates navigation in programming mode

 Burner lit

 DHW mode (symbol will flash with demand)

 Heating mode (symbol will flash with demand)

$^{\circ}\text{C}$ Units for temperature

$^{\circ}\text{F}$ Units for temperature

5d Service due (see 4.2)

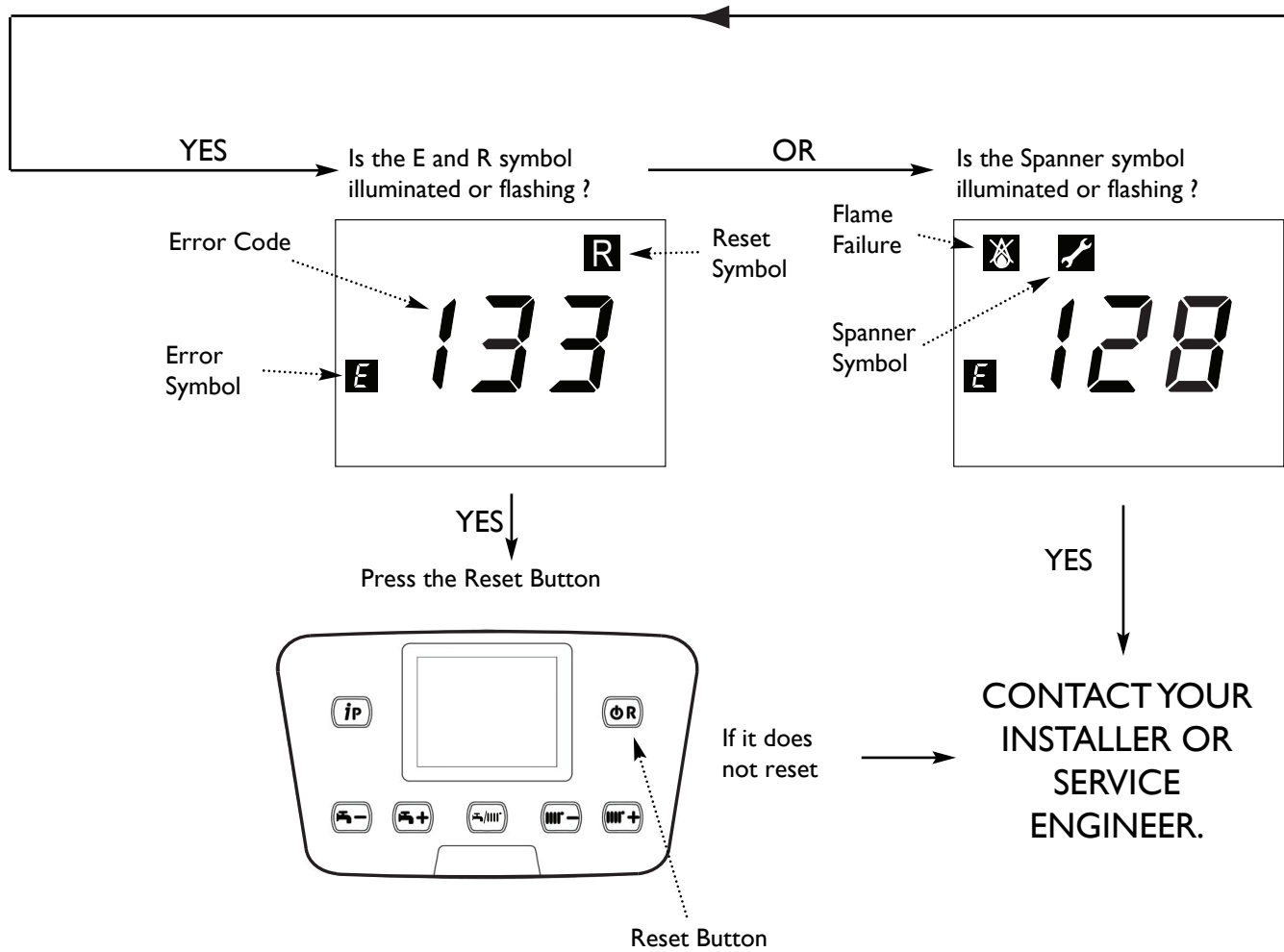
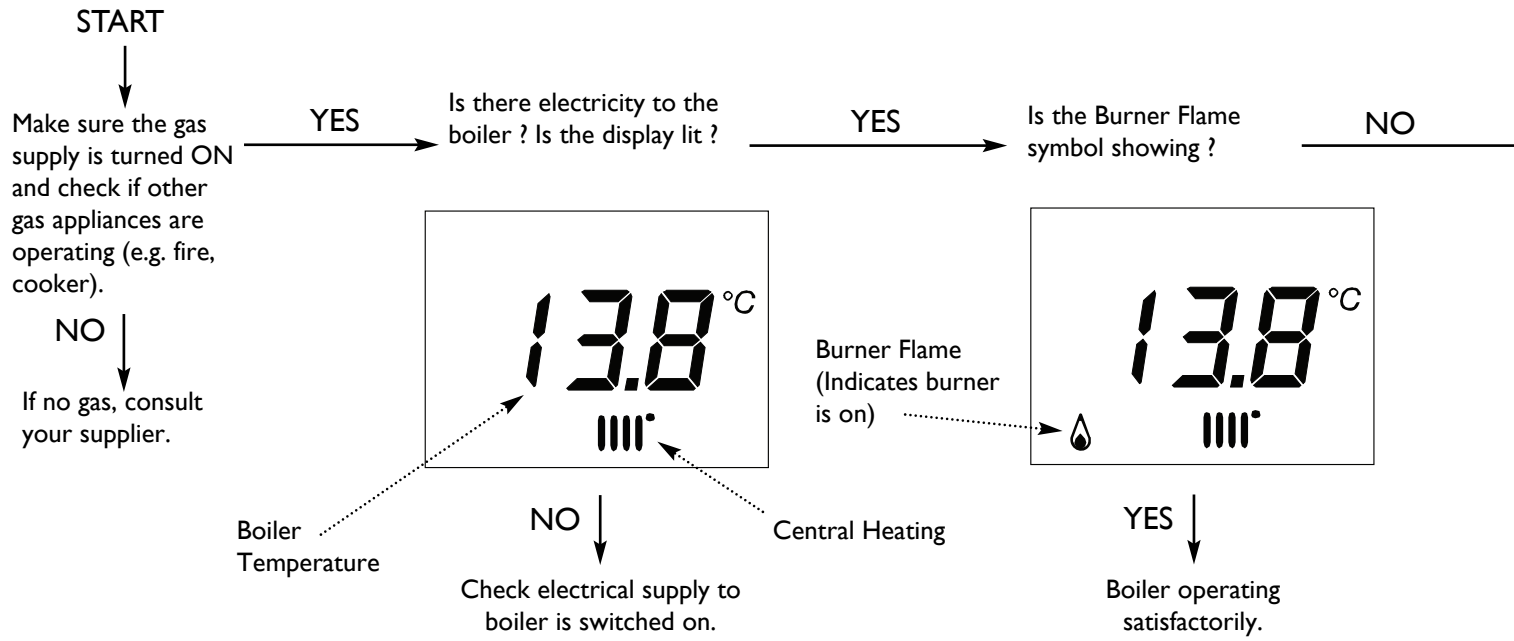

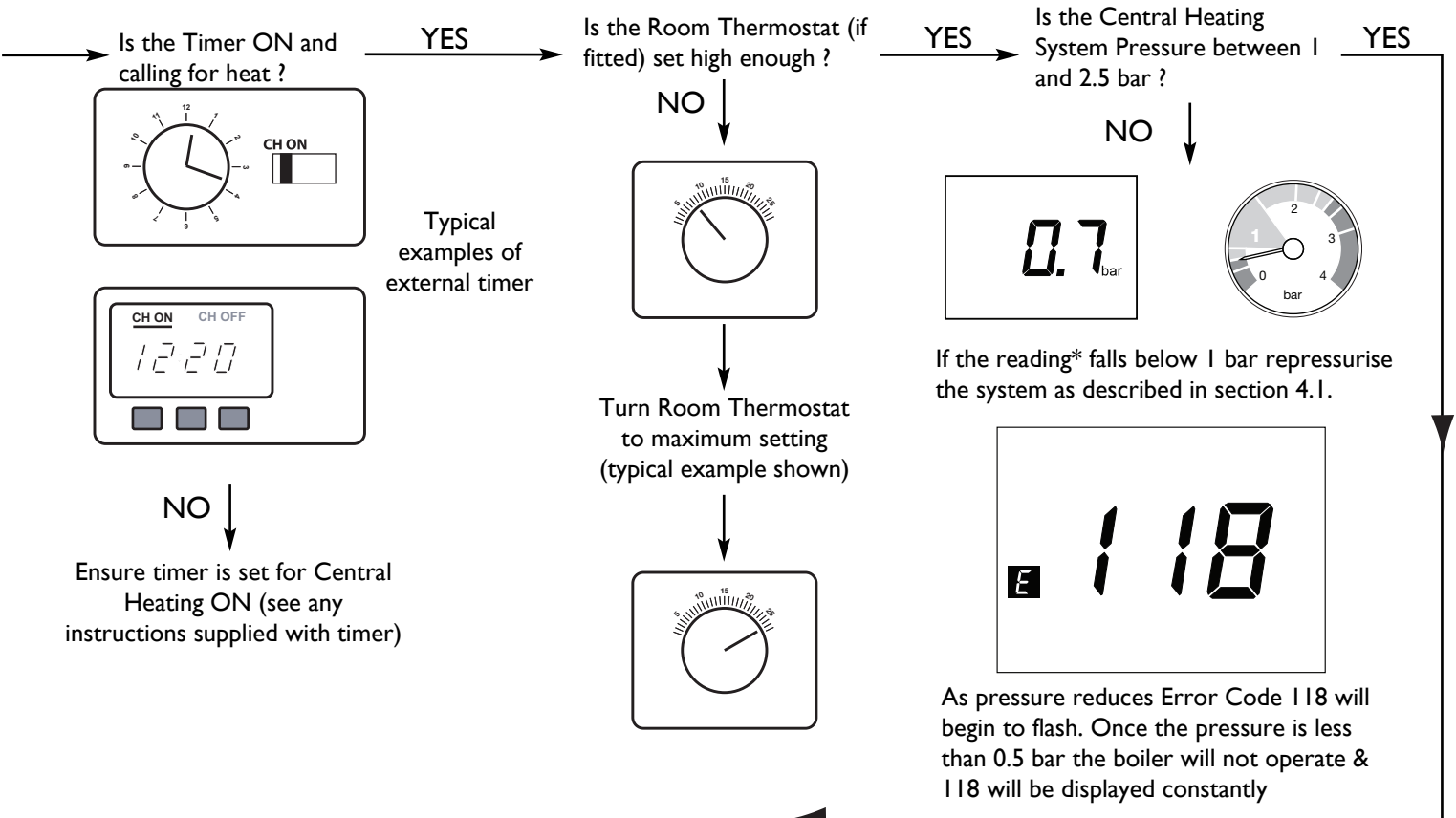

*To check the water pressure press **i P** until **i 05** is displayed. This will alternate with the system pressure. (NOTE: When the pump is running the gauge under the boiler may show a slightly different reading to the display)

If you don't know what you need to do to get the boiler to light, or need help with the system and controls, contact your installer as soon as possible

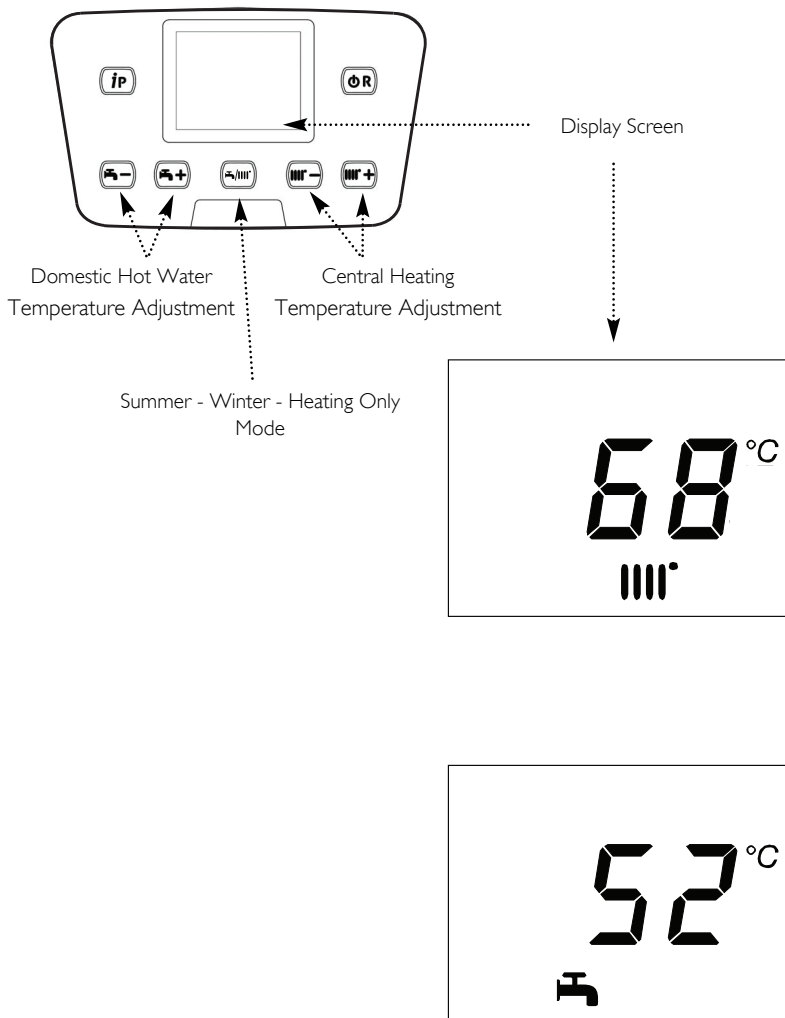

The **iP** button can be pressed so that the display shows the following information:-

- '00' alternates with Sub-Code (only when fault on boiler) or '000'
- '01' alternates with CH Flow Temperature
- '02' alternates with Outside Temperature (where Sensor fitted)
- '03' alternates with DHW Temperature
- '04' alternates with DHW Temperature
- '05' alternates with System Water Pressure
- '06' alternates with CH Return Temperature
- '07' alternates with Flue Temperature
- '08' - not used
- '10' alternates with Zone 1 CH Flow Temperature
- '11' alternates with Zone 2 CH Flow Temperature
- '12' alternates with Ion current
- '13' alternates with Burner working hours
- '14' alternates with Zone 1 CH mode
- '15' alternates with Zone 2 CH mode
- '16' alternates with DHW circuit operating mode
- '17' alternates with Boiler operating mode
- '18' alternates with Solar plant operating mode
- '19' alternates with Manufacturer information
- '20' alternates with Manufacturer information

3.0 Temperature Adjustment & Care of the Boiler

3.1 To adjust the central heating temperature

1. Press **||| +** to increase the Central Heating temperature.
2. Press **||| -** to decrease the Central Heating temperature.

NOTE: An overheat thermostat (NTC) is positioned in the heat exchanger which shuts down the appliance if the boiler temperature exceeds 100°C. Press **OR** button to re-establish normal operating conditions.

3.2 To adjust the domestic hot water temperature

1. Press **⚗ +** to increase the Domestic Hot Water temperature.
2. Press **⚗ -** to decrease the Domestic Hot Water temperature.

3.3 Summer - Winter - Heating Only Mode

1. Press **⚗/|||** until the required mode is displayed:-
 - ⚗** Summer - Domestic Hot Water only mode
 - ⚗ |||** Winter - Domestic Hot Water & Central Heating mode
 - |||** Heating Only - Only Central Heating mode

2. See 3.1 or 3.2 to set the required temperature.

3.4 Cleaning the Outer Case

The painted panels should be wiped with a damp cloth and then dried completely. **DO NOT USE ABRASIVE CLEANING AGENTS.**

3.5 Boiler Frost Protection

1. The boiler incorporates an integral frost protection feature that will operate in both Central Heating & Domestic Hot Water modes, and also when in standby (**⏻** displayed).
2. If the boiler temperature falls below 5° C, then the boiler will operate until the water temperature has been raised.
3. Further protection may be required for the system. Consult your installer for details.

3.6 Information Display

1. The table opposite shows information that can be displayed by pressing the **iP** button.
2. Depending upon boiler model and any system controls connected to the appliance, not all information codes will be displayed and some that are will not have a value.
3. Press **OR** to return to the normal display.

4.0 Repressurising System & 'Service Due'

4.1 Central Heating System Pressure

1. The normal operating water pressure is between 1 and 2.5 bar (Fig. 1). If the pressure exceeds 3 bar the safety pressure valve will operate and a fault is indicated (E117 displayed). Contact your installer.

2. It may be necessary to repressurise the system occasionally (as Fig. 2 or E118 displayed). A filling device (the filling loop) will be fitted on the system. This will be on the boiler itself, or on pipework near to the boiler.

3. If you are unsure of its position, or cannot identify it, consult the installer who fitted the boiler.

Note: It is recommended that repressurising is performed when the boiler & system are cool.

4. The filling loop supplied consists of two taps and a separate copper pipe with connection fittings.

5. Only when repressurising should the copper pipe be connected between the two taps. Ensure that the nuts on the pipe ends are tightened onto the taps.

6. Fully open one of the taps first, and then while watching the pressure gauge, carefully open the second tap.

7. The system pressure is shown at all times on the gauge under the boiler and can be viewed on the display when there is power to the boiler.

8. To check the water pressure press **iP** until **05** is displayed. This will alternate with the system pressure. (**NOTE:** When the pump is running the gauge under the boiler may show a slightly different reading to the display).

9. When the needle on the gauge or figures on the display indicate 1 or more turn both taps off.

10. Disconnect the copper pipe from the taps (a small amount of water may be present) and remove it. Keep the pipe in a safe place for future use.

4.2 'Service Due' Message

1. After 11 months operation the 'Service Due' message will be shown on the boiler display.

2. Please contact 'heateam' - The Service Division of Baxi to arrange your Annual Service. You can contact 'heateam' 0844 241 2502 or e-mail field.trial.uk@bdrthermea.com

Front, Side Panel and Control Box removed for clarity

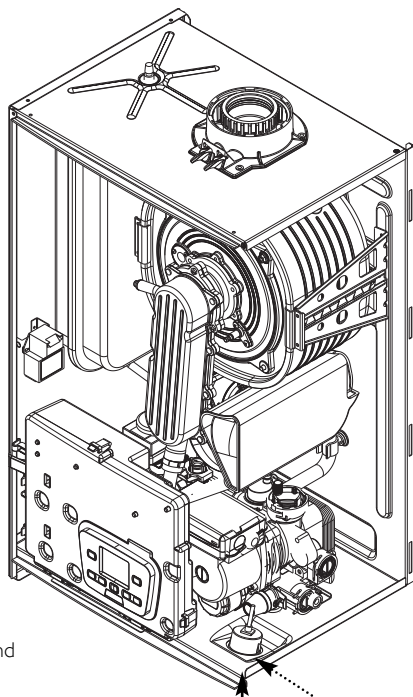

View Under Appliance

Pressure Gauge



Fig. 1

Normal Pressure

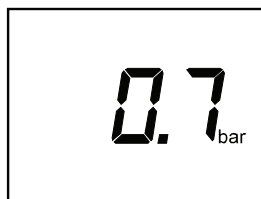
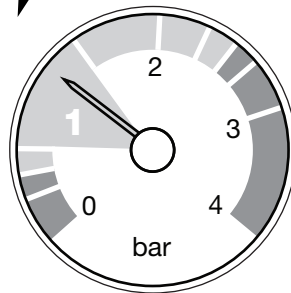
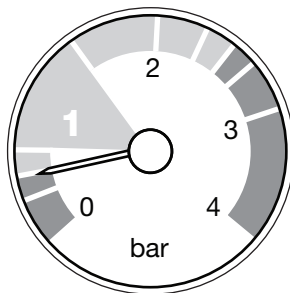

Fig. 2

Requires
Repressurising



'Service Due' Message
'Sd' will show for three seconds, alternating with the boiler temperature.



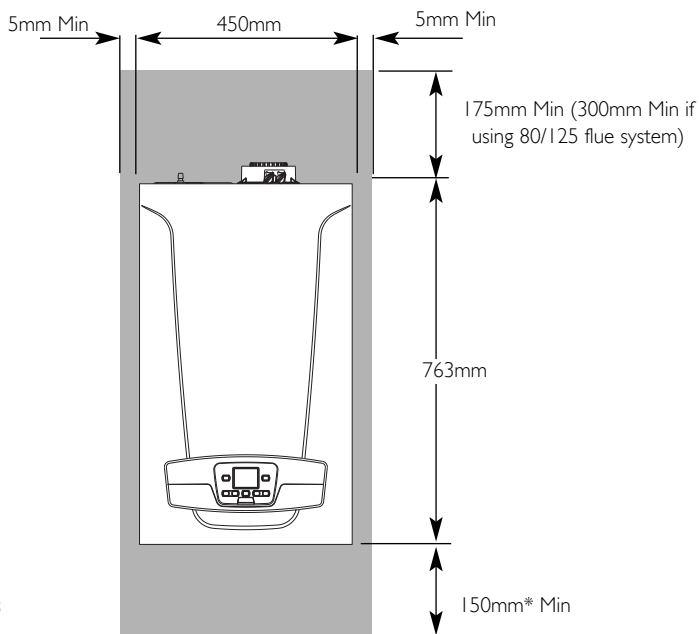

Fig. 3

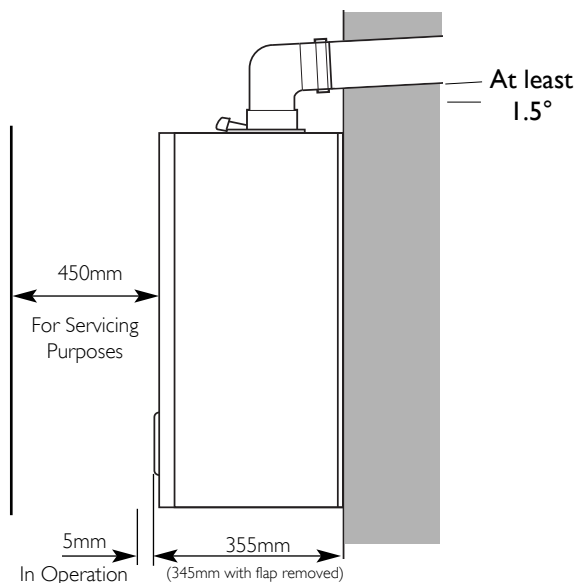

Fig. 4

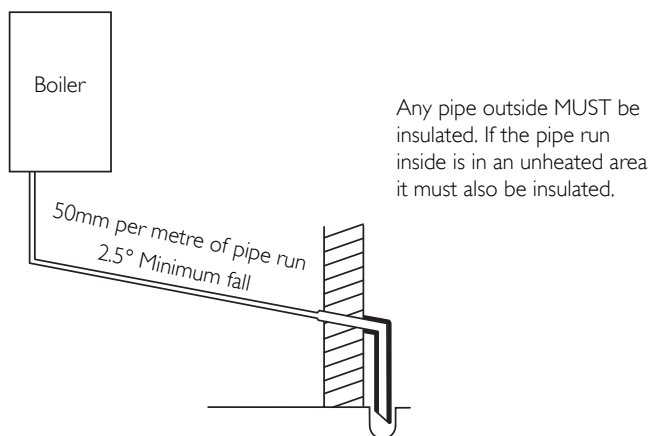

Fig. 5 Example of condensate drain system

5.0 Clearances

5.1 For your Safety

1. This appliance must have been installed in accordance with the manufacturer's instructions and the regulations in force.

2. Any modification that may interfere with the normal operation of the appliance without express written permission from the manufacturer or his agent could invalidate the appliance warranty. In GB this could also infringe the Gas Safety (Installation and Use) Regulations.

GB - Heating Industry definition meaning England, Scotland, Wales, Northern Ireland, Isle of Man and the Channel Isles

3. Your boiler must not be operated without the casing correctly fitted.

4. Do not interfere with any sealed components on this boiler.

5. Take note of any warning labels on your boiler.

6. Your boiler should have the following minimum clearances for Safety and Maintenance (Figs. 3 & 4):-

Top	- 175mm
Bottom	- 150mm*
Left side	- 5mm
Right Side	- 5mm
Front	- 5mm (In Operation) - 450mm (For Servicing)

*This is MINIMUM recommended dimension. Greater clearance will aid installation and maintenance.

7. If your boiler is installed in a compartment, do not use it for storage purposes. Do not obstruct any purpose provided ventilation openings.

8. Flammable materials must not be stored in close proximity to your boiler.

9. Avoid skin contact when your boiler is in operation, as some surfaces may get hot e.g. pipework.

10. Ensure that the flue terminal, outside the house, does not become damaged or obstructed, particularly by foliage.

11. It is important that the condensate drain system is not blocked, modified or damaged in any way as this would affect the operation of your boiler. Your installer should have insulated any exposed pipework (Fig. 5).



Table Of Error Codes

E 20	🔧	Central Heating NTC Fault
E 28	🔧	Flue NTC Fault
E 40	🔧	Central Heating Return NTC Fault
E 110	R 🔧	Safety Thermostat Operated (pump fault or air in primary)
E 111	R 🔧	Safety Thermostat Operated (over temperature)
E 117	🔧	Primary System Water Pressure Too High
E 118	🔧	Primary System Water Pressure Too Low
E 125	R 🔧	Circulation Fault (Primary)
E 128		Flame Failure (no lock-out)
E 130	🔧	Flue NTC Operated
E 133	R 🔧	Interruption Of Gas Supply or Flame Failure
E 151	R 🔧	Flame Failure
E 160	R	Fan or Fan Wiring Fault
E 321	🔧	Hot Water NTC Fault
E 384		False Flame

6.0 Error Codes

6.1 List of Error Codes

1. When an error occurs the display will show one of two symbols: 🔧 or R.

In both cases the display will also show E symbol and the numeric value of the error (see the "error table" below).

2. 🔧 When the spanner is displayed the error cannot be reset by the user. Please contact 'heateam' - The Service Division of Baxi on 0844 241 2502 or e-mail field.trial.uk@bdrthermea.com

3. R fault errors can be reset by pressing the OR button and holding for two seconds.

WARNING: If an error code different from those described opposite appears on the display or a certain fault appears frequently, contact 'heateam'.

7.0 Legislation

7.1 Installation, Commissioning, Service & Repair

1. This appliance must be installed in accordance with the manufacturer's instructions and the regulations in force. Read the instructions fully before installing or using the appliance.
2. In GB, this must be carried out by a competent person as stated in the Gas Safety (Installation & Use) Regulations.
3. **Definition of competence:** A person who works for a Gas Safe registered company and holding current certificates in the relevant ACS modules, is deemed competent.
4. In IE (Eire), this must be carried out by a competent person as stated in I.S. 813 "Domestic Gas Installations".

Lifting - This product should be lifted and handled by two people. Stooping should be avoided and protective equipment worn where necessary. Carrying & lifting equipment should be used as required, e.g. when installing in a loft space.

All Gas Safe registered engineers carry an ID card with their licence number and a photograph. You can check your engineer is registered by telephoning 0800 408 5500 or online at www.gassaferegister.co.uk

The boiler meets the requirements of Statutory Instrument "The Boiler (Efficiency) Regulations 1993 No 3083" and is deemed to meet the requirements of Directive 92/42/EEC on the energy efficiency requirements for new hot water boilers fired with liquid or gaseous fuels:-

Type test for purpose of Regulation 5 certified by:
Notified Body 0085.

Product/Production certified by:
Notified Body 0086.
Ref: 86-BL-647

For GB/IE only.

7.2 Benchmark Commissioning Checklist

1. Please ensure that the installer has fully completed the Benchmark Checklist on the inside back pages of the installation instructions supplied with the product and that you have signed it to say that you have received a full and clear explanation of its operation. The installer is legally required to complete a commissioning checklist as a means of complying with the appropriate Building Regulations (England and Wales).
 2. All installations must be notified to Local Area Building Control either directly or through a Competent Persons Scheme. A Building Regulations Compliance Certificate will then be issued to the customer who should, on receipt, write the Notification Number on the Benchmark Checklist.
 3. This product should be serviced regularly to optimise its safety, efficiency and performance. The service engineer should complete the relevant Service Record on the Benchmark Checklist after each service.
 4. The completed Benchmark Checklist may be required in the event of any warranty work.
-

Warning !

If you smell gas

Do not operate light switches
Do not operate any electrical equipment
Do not use a telephone in the hazardous area
Extinguish any naked flame and do not smoke
Open windows and doors in the hazardous area
Turn off the gas supply at the meter
Warn any other occupants and vacate the premises
Telephone the National Gas Emergency Service on:-
0800 111 999

Faulty boiler

If it is known or suspected that there is a fault on the boiler that cannot be manually reset, it must not be used until the fault has been corrected by a competent person.

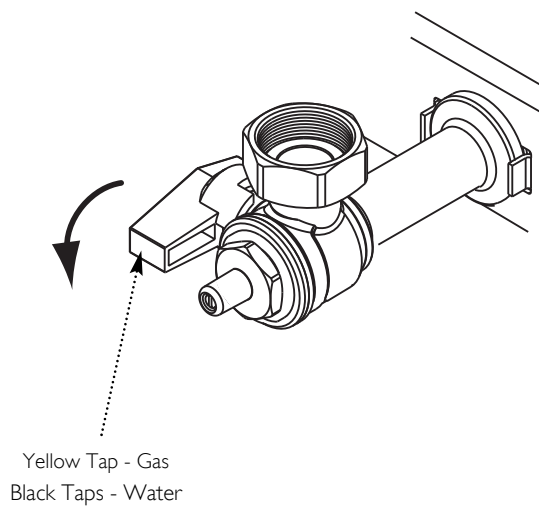

In an Emergency

1. If a water or gas leak occurs or is suspected, the boiler can be isolated at the inlet valves by turning their taps through 90° (1/4 turn) downwards
2. Please contact your Installer, Annual Service Provider or 'heateam' - The Service Division of Baxi. You can contact 'heateam' on telephone number **0844 241 2502** or e-mail field.trial.uk@bdrthermea.com as soon as possible.

Please complete the boxes below

Serial Number

Date of Installation

D	D	M	M	Y	Y

Installer Details (name, address and contact number(s))

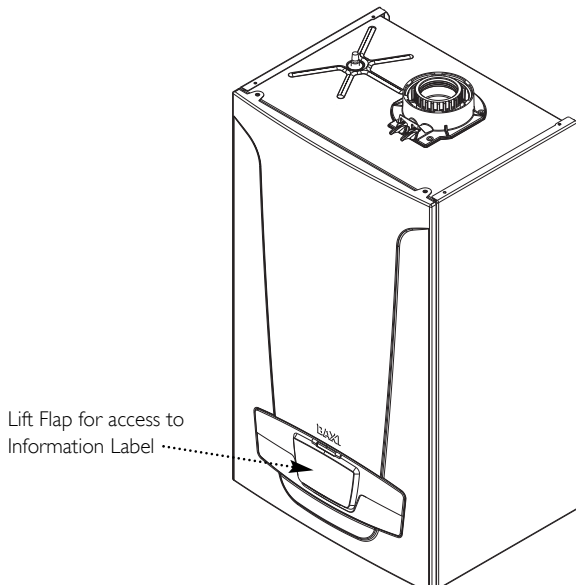

All descriptions and illustrations provided in this leaflet have been carefully prepared but we reserve the right to make changes and improvements in our products which may affect the accuracy of the information contained in this leaflet. All goods are sold subject to our standard Conditions of Sale which are available on request.

BAXI
A Trading Division of Baxi Heating UK Ltd (3879156)
Brooks House, Coventry Road, Warwick. CV34 4LL
Website www.baxi.co.uk
e&oe

PART OF BDR THERMEA

9.0 Warranty & Service

Standard Warranty Terms & Conditions

Your free 2 year warranty will be pre-registered.

It is also a requirement of the warranty that the boiler has an annual service (every 12 months) in accordance with the installation and servicing instructions, performed by a Gas Safe registered engineer.

If you would like **heateam** to carry this out please call on **0844 241 2502** or e-mail field.trial.uk@bdrthermea.com.

Our promise to you

If you experience a fault with your new boiler, we aim to provide a safe and high quality repair service supported by our dedicated national network of highly skilled engineers. If your installer can't resolve the problem for you, we will do everything we can to get an engineer out to you as quickly as possible. Nothing in this warranty will affect your statutory consumer rights.

What you need to do if you experience a problem with your heating system or the operation of the boiler

You should always contact your installer first, because the cause of the fault may not be related to the boiler. If your installer confirms that the fault is with the boiler and he/she can't repair it, our friendly customer service team is on hand to help. Simply call our service division **heateam** on **0844 241 2502** or e-mail field.trial.uk@bdrthermea.com to book an engineer visit or for any general advice that you may need. Our contact centre is open Monday to Friday 8am - 6pm, weekends and Bank Holidays 8.30am - 2pm, excluding Christmas Day and New Years Day.

When contacting **heateam** it would be helpful if you could have the following information to hand:-

- 1 Boiler serial number (see opposite).
- 2 Boiler make and model number.

What this warranty covers

Free of charge repair or replacement of components found to be of faulty manufacture.

Free of charge replacement of the complete unit provided always that the failure is related to a manufacturing fault that cannot be repaired or is uneconomic to repair.

What this warranty does not cover

Repairs to boilers which haven't been installed and commissioned properly, and as set out in the installation instructions (this includes the need to flush the system effectively and add a suitable corrosion inhibitor).

Any damage caused by hard water scale deposits and/or aggressive water resulting from corrosion.

Any other defects or failures, either in the connected heating system or outside of the boiler itself.

Faults caused by inadequate supply of electricity, gas or water to the property.

Installations within commercial settings for which this boiler was not designed.

Reimbursement of any third party repair or replacement costs that we haven't been told about or agreed with you in advance.

Compensation for consequential losses (e.g. loss of earnings, business losses, stress and inconvenience) arising from a production breakdown, including repair delays caused by factors outside our reasonable control.

After Sales Service **0844 241 2502** or e-mail field.trial.uk@bdrthermea.com.