

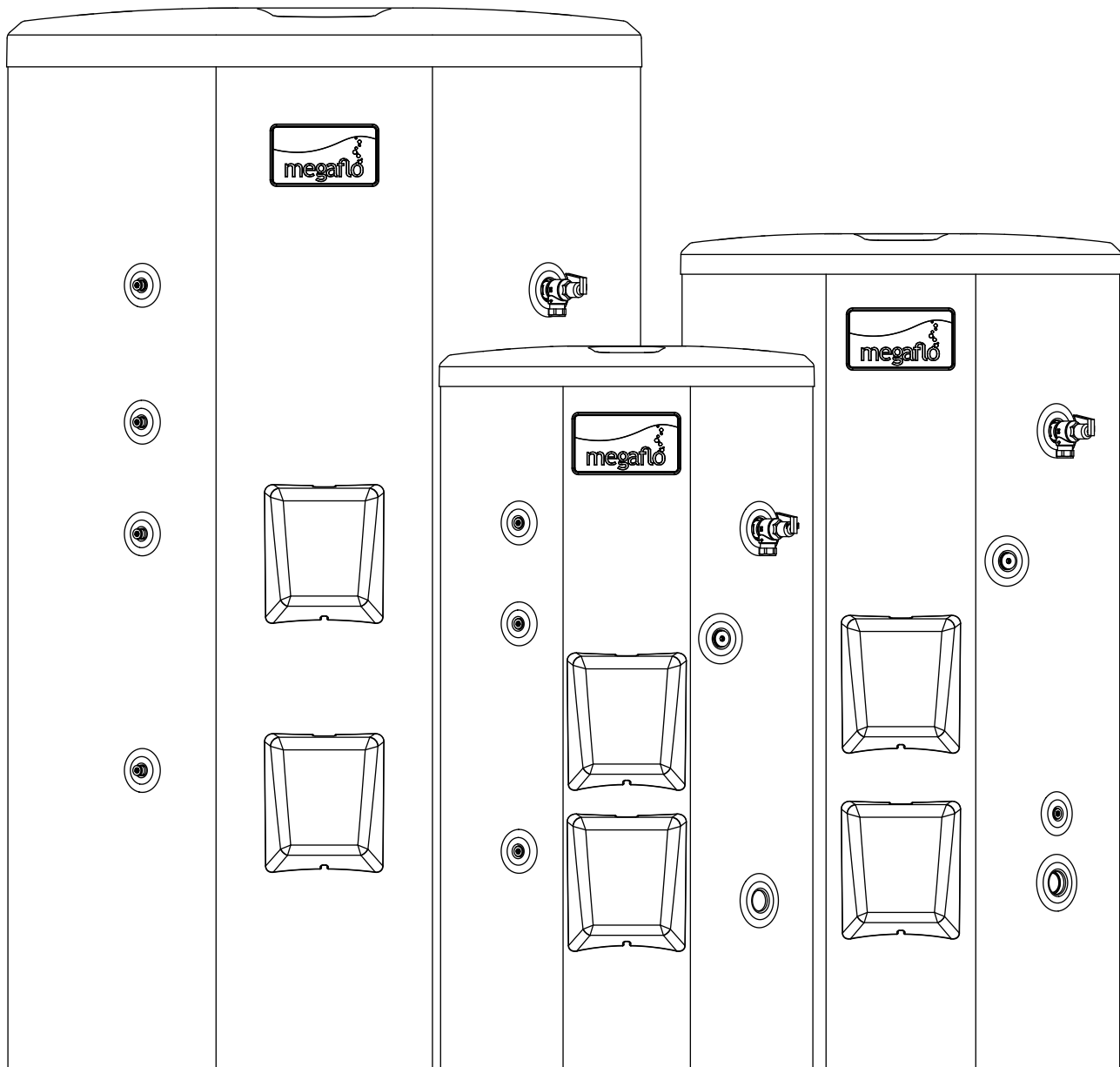

Unvented Direct & Indirect Hot Water Cylinders (400L - 2500L)



Important

Please read & understand all these instructions before commencing installation.
Please leave this manual with the customer for future reference

Contents

Product Specification	3
Introduction	3
General requirements	3
THE BENCHMARK™ SCHEME	3
Checklist	4
Storage and handling	5
Operational summary	6
Technical data	8
Thermostat control schematics	13
Limitations	14
Water supply	14
Installation & Commissioning	15
General Installation	15
Cold Water Supply	15
Discharge Pipe work	20
Indirect Model	22
Commissioning	23
Maintenance & Servicing	25
Maintenance requirements	25
Clean the strainer	25
Fault finding	27
Benchmark log book	28
Spares	30
Servicing	30
Spares drawings	32
User Guide	32
Lifetime Guarantee Terms and Conditions	38



Product specification

Introduction

Congratulations on your purchase of a MEGAFLO **Commercial** unvented water heater. The MEGAFLO **Commercial** products are manufactured in the UK from top quality materials and meets all the latest relevant safety and constructional standards. The high grade Duplex stainless steel cylinder offers exceptional strength and corrosion resistance which is backed by a 25 year guarantee* Its performance and insulation levels exceed the latest requirements of Building Regulation Part L.

The MEGAFLO **Commercial** unvented water heater can be fed directly from the cold water mains supply to the property without the need for separate feed cisterns or vent pipes. It is supplied complete with all its necessary inlet and safety controls.

The MEGAFLO **Commercial** cylinder range all require a separate expansion vessel to accommodate any expanded water.

General Requirements

IMPORTANT: Please read and understand this product guide before installing the MEGAFLO **Commercial** water heater. Incorrect installation may invalidate the guarantee*.

The MEGAFLO **Commercial** must be Installed, Commissioned and Maintained by a competent installer in accordance with Building Regulation G3 (England and Wales), Technical Standard P3 (Scotland) or Building Regulation P5 (Northern Ireland) and the Water Fitting Regulations (England and Wales) or Water Byelaws (Scotland).

THIS APPLIANCE CAN BE USED BY CHILDREN AGED FROM 8 YEARS AND ABOVE AND PERSONS WITH REDUCED PHYSICAL, SENSORY OR MENTAL CAPABILITIES OR LACK OF EXPERIENCE AND KNOWLEDGE IF THEY HAVE BEEN GIVEN SUPERVISION OR INSTRUCTION CONCERNING USE OF THE APPLIANCE IN A SAFE WAY AND UNDERSTAND THE HAZARDS INVOLVED. CHILDREN SHALL NOT PLAY WITH THE APPLIANCE. CLEANING AND USER MAINTENANCE SHALL NOT BE MADE BY CHILDREN WITHOUT SUPERVISION

WARNING: Do not switch on if there is a possibility that the water in the heater is frozen.

THE BENCHMARK™ SCHEME

Benchmark™ places responsibilities on both manufacturers and installers. The purpose is to ensure that customers are provided with the correct equipment for their needs, that it is installed, commissioned and serviced in accordance with the manufacturer's instructions by competent persons and that it meets the requirements of the appropriate Building Regulations. The Benchmark™ Checklist can be used to demonstrate compliance with Building Regulations and should be provided to the customer for future reference.

Installers are required to carry out installation, commissioning and servicing work in accordance with the Benchmark™ Code of Practice which is available from the Heating and Hotwater Industry Council who manage and promote the Scheme. Visit www.centralheating.co.uk for more information.

* See Terms and Conditions of guarantee on page 38

Note: This Megaflo commercial cylinder needs a minimum 100L/min water supply at open outlet.



Checklist

Before commencing installation check that all the components for your MEGAFLO **Commercial** unit are contained in the package. The following components are supplied as standard with your MEGAFLO **Commercial** unit:

- Table 1: Cold Water Inlet Control Kit (as below, depending on model)

Commercial Cylinder Volume (ltr)	Pressure Reducing Valve	Pressure Relief Valve	Single Check Valve
400 - 500	1" Integrated inlet control valve		
800	1.25" (1.5 - 6 bar) or (5 -10 bar)	1" x 1.25" (8 bar) or (13 bar)	1.25"
1000	1.25" (1.5 - 6 bar) or (5 -10 bar)	1" x 1.25" (8 bar) or (13 bar)	1.25"
1250 - 1450	1.5" (1.5 - 6 bar) or (5 -10 bar)	1" x 1.25" (8 bar) or (13 bar)	1.5"
2000 - 2500	2" (1.5 - 6 bar) or (5 -10 bar)	1.25" x 1.5" (8 bar) or (13 bar)	2"

- Table 2: Expansion Vessel (as below)

Commercial Cylinder Volume (ltr)	Expansion Vessel Size (ltr)	Mounting Kit	Weights
400 - 500	60	Floor Mounted	12kg
800	100	Floor Mounted	17kg
1000 - 1250	150	Floor Mounted	24kg
1450	200	Floor Mounted	38.5kg
2000 - 2500	300	Floor Mounted	41kg

- Factory fitted Temperature & Pressure Relief Valve, set at 90°C / 1 MPa (10bar) or factory fitted Temperature & Pressure Relief valve set at 90°C / 1.5MPa (15bar) Depending on model. Connection size 1 1/4" BSP to cylinder, 28mm compression fitting out.
- Tundish 1 1/4" inlet/ 1 1/2" outlet
- Thermostat and Thermal cut-out (Indirect units only)
- Isolating Valve (1", 1.25", 1.5" or 2") Depending on model
- 1" Drain Valve
- 2-Port Motorised Valve (Indirect units only)
- All connections BSP female

Notes:

1" Integrated inlet control valve is not assembled.

Storage and Handling

Please take care when handling a packaged MEGAFLO **Commercial**. The unit is heavy and must only be moved manually within safe working practices. If the unit is to be stored before installation, it must be placed on a secure, level surface and in a dry, frost free environment.

Precautions to be carried out prior to commencement of work:

1. Tidy area ensuring there is safe access and egress to installation place, free from trip hazards.
2. Be aware of other people who may be in the area
3. Operate any machinery in accordance with training and operating instructions
4. Visually inspect the equipment prior to use, do not use damaged equipment.
5. Safe working practices are adopted for manual handling of appliances/parts
6. Correct PPE to be worn.

The MEGAFLO **Commercial** unit must be vertically floor mounted. It can be placed anywhere convenient provided the discharge pipe(s) from its safety valves can be correctly installed. Areas that are subject to freezing must be avoided. Ensure that the floor is level and of sufficient strength to support the "full" weight of the unit when filled with water (refer to Table 4 on page 8 or Table 6, page 9 for unit weights). Pipe runs should be kept as short as possible for maximum economy. Access to associated controls, immersion heaters and indirect controls should be possible for servicing and maintenance of the system.

To aid installation, the MEGAFLO **Commercial** is provided with lifting points located at the top of the unit. To access the lifting eyes please remove the top cover. The weights of the units are noted on Table 4, page 8 or Table 6, page 9.

FIGURE 1: Lifting

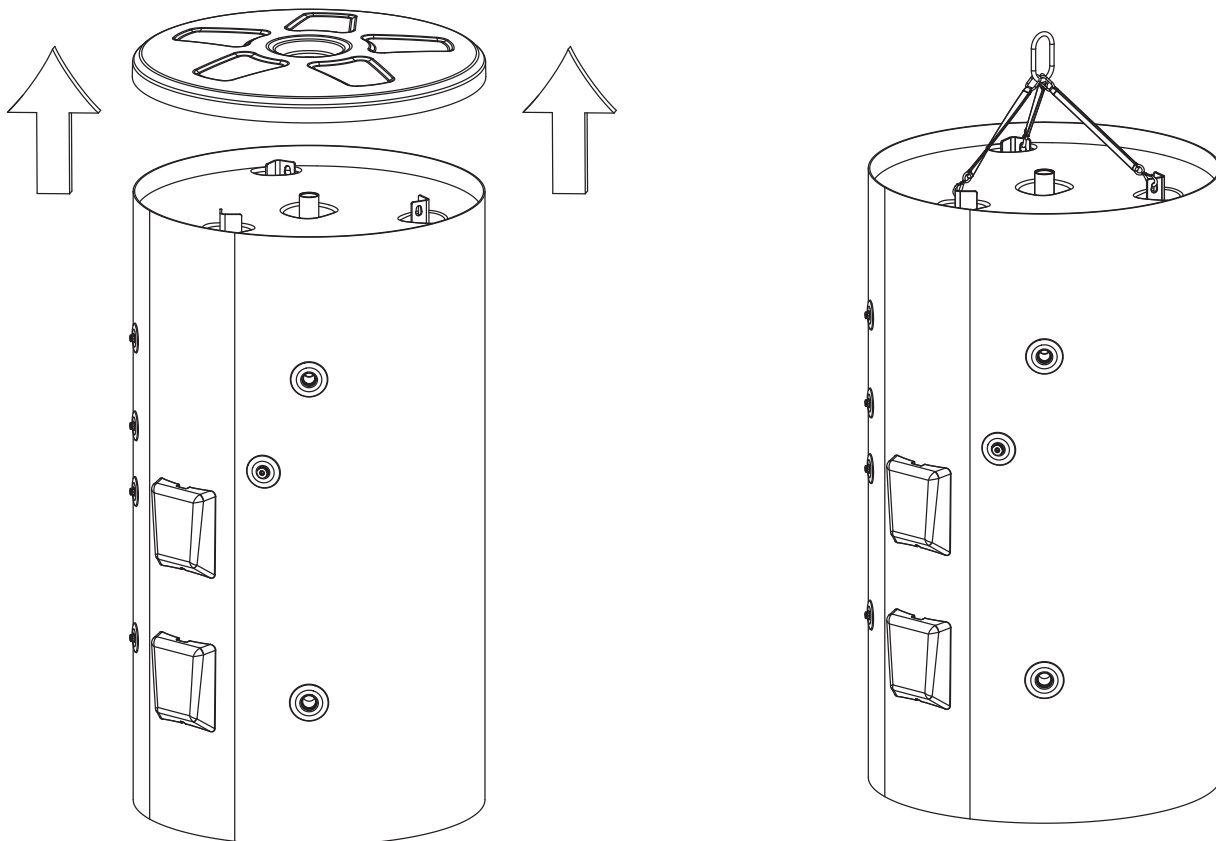

OPERATIONAL SUMMARY (Indirect models in conformance with BS EN 12897:2006)

Maximum mains water supply pressure	2.5MPa (25 bar)
Operating pressure/PRV (low pressure system)	0.60MPa (6. bar)
Operating pressure/PRV (high pressure system)	1.00MPa (10 bar)
Expansion vessel pressure (low pressure system)	1.0MPa (10 bar max)
Expansion vessel pressure (high pressure system)	1.6MPa (16 bar max)
Expansion relief valve setting (low pressure system)	0.8MPa (8 bar)
Expansion relief valve setting (high pressure system)	1.3MPa (13 bar)
Maximum design pressure (low pressure system)	0.80MPa (8 bar)
Maximum design pressure (high pressure system)	1.3MPa (13 bar)
T&P relief valve setting	1.0MPa/90 °C (10 bar)
T&P relief valve setting	1.5MPa/90 °C (15 bar)
Primary coil operating pressure (max)	0.30MPa (3 bar)
Immersion heater rating (a.c. supply only) single phase	6kW & 9kW 50/60Hz ~
Immersion heater rating (a.c. supply only) 3 phase	12kW - 54kW 50/60Hz ~
(See Accessories on page 35 for full range)	
Primary Coil ratings	See Table 10, page 10
Pressure drop across coils	See table 11, page 10
Storage weights (empty and full)	See Table 4, Page 8 See Table 6, Page 9
Coil surface area	See table 10, page 10

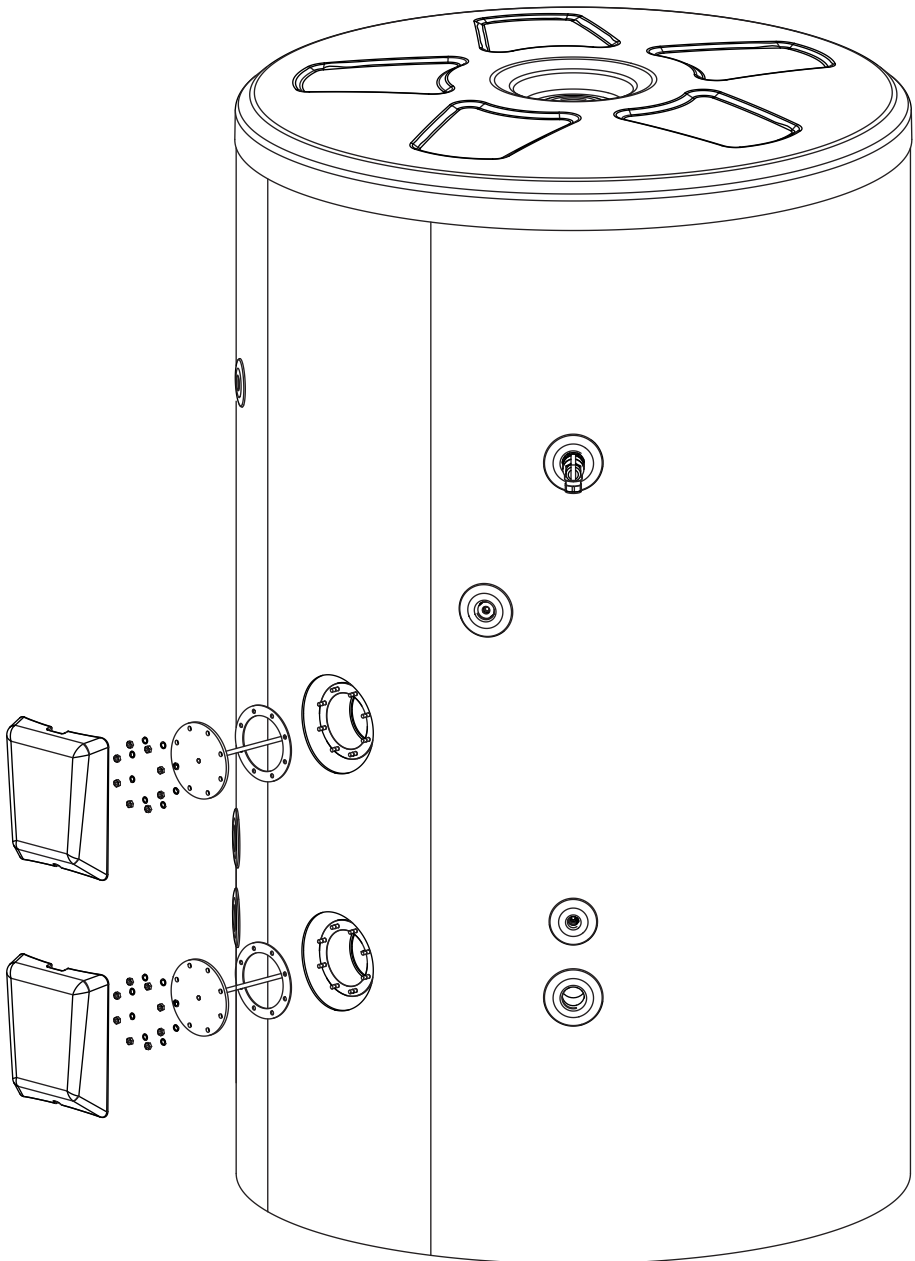

FIGURE 2: Indirect dimensions

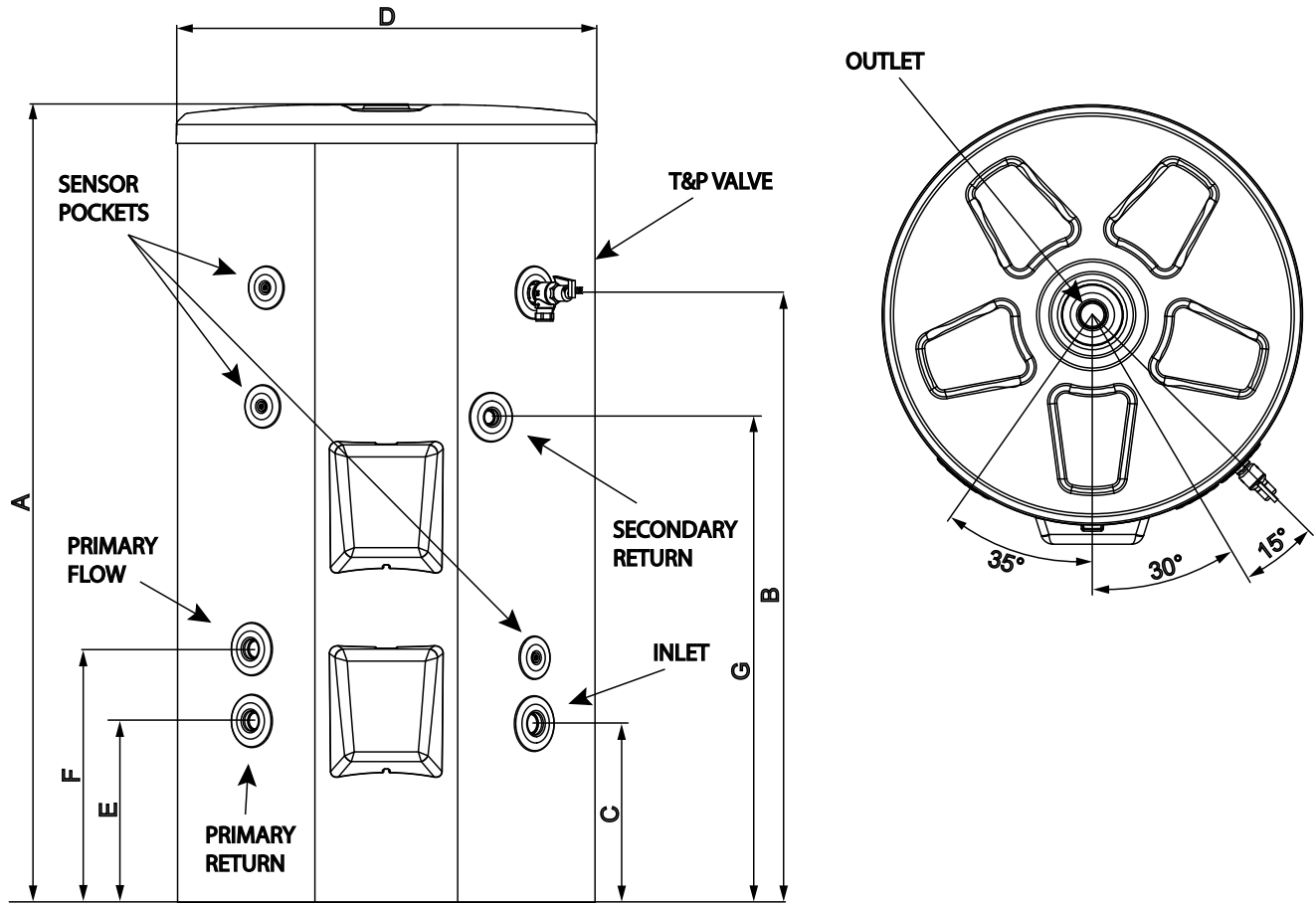

Table 3: Indirect measurements

Direct	Connection	400l	500l	Connection	800l	1000l	Connection	1250l	1450l	Connection	2000l	2500l
A	N/A	1535	1804	N/A	1906	2301	N/A	1936	2253	N/A	2014	2419
B	N/A	1264	1416	N/A	1487	1882	N/A	1408	1693	N/A	1410	1515
C	1 1/4" BSP	400	399	1 1/2" BSP	437	437	1 1/2" BSP	523	527	2" BSP	606	605
D	N/A	872	872	N/A	1024	1024	N/A	1224	1224	N/A	1470	1470
E	1 1/4" BSP	418	418	1 1/4" BSP	443	443	1 1/2" BSP	527	527	1 1/2" BSP	599	599
F	1 1/4" BSP	593	593	1 1/4" BSP	618	618	1 1/2" BSP	707	707	1 1/2" BSP	779	779
G	1" BSP	1008	1108	1" BSP	1183	1433	1" BSP	1172	1373	1" BSP	1225	1474

NOTE: All connections BSP female threads

Table 4: Indirect weights

Size (Litres)	Unit Weight (kg)	
	Empty	Full
400	105	505
500	110	610
800	164	964
1000	188	1188
1250	319	1569
1450	322	1872
2000	445	2445
2500	450	2950

FIGURE 3: Direct dimensions

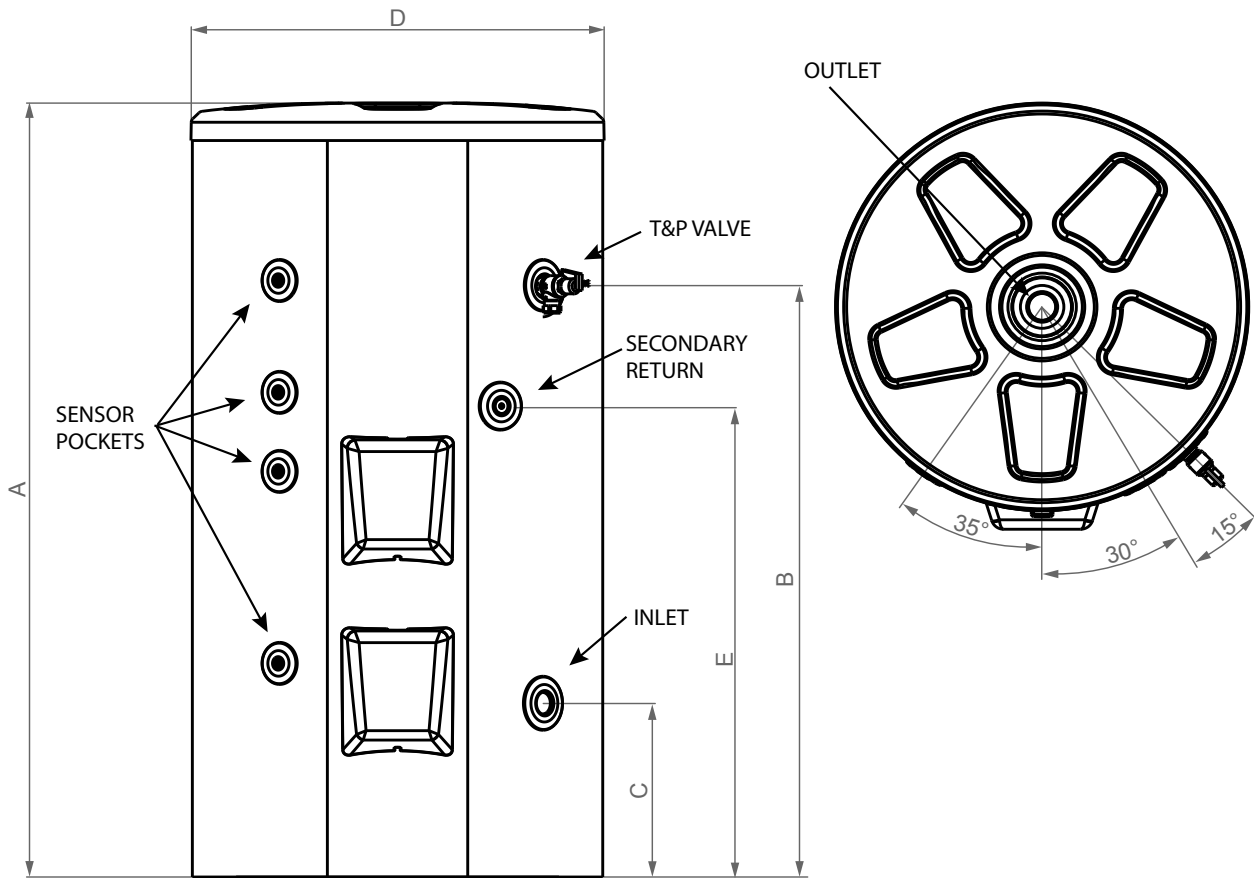

Table 5: Direct measurements

Direct	Connection	400L	500L	Connection	800L	1000L	Connection	1250L	1450L	Connection	2000L	2500L
A	N/A	1535	1804	N/A	1906	2301	N/A	1936	2253	N/A	2014	2419
B	N/A	1264	1416	N/A	1487	1882	N/A	1408	1693	N/A	1410	1515
C	1 1/4" BSP	400	399	1 1/2" BSP	437	437	1 1/2" BSP	523	527	2" BSP	606	605
D	N/A	872	872	N/A	1024	1024	N/A	1224	1224	N/A	1470	1470
E	1" BSP	1008	1108	1" BSP	1183	1433	1" BSP	1172	1373	1" BSP	1225	1474

NOTE: All connections BSP female threads

Table 6: Direct weights

Size (Litres)	Unit Weight (kg)	
	Empty	Full
400	95	495
500	100	600
800	153	953
1000	178	1178
1250	297	1547
1450	304	1754
2000	415	2415
2500	421	2921

Table 9: Standing heat-loss

NOMINAL CAPACITY (LITRES)	STANDING HEAT LOSS	
	PER DAY (kWh/24h)	PER YEAR (kWh/24h)
400	1.72	627
500	2.14	781
800	2.74	1000
1000	3.33	1215
1250	3.60	1314
1450	4.17	1522
2000	4.30	1569
2500	4.50	1642

Table 10: Indirect coil kW ratings

NOMINAL CAPACITY (LITRES)	PRIMARY FLOW RATE l/min			COIL SURFACE AREA
	15	30	60	
400	29.4kW	43.6kW	59.7kW	2m ²
500	28.7kW	41.8kW	55.8kW	
800	31.3kW	52.7kW	76.9kW	3m ²
1000	32.9kW	51.4kW	76.5kW	
1250	35.0kW	63.6kW	97.9kW	5m ²
1450	30.1kW	61.2kW	91.7kW	
2000	40.2kW	98.4kW	132.2kW	7.5m ²
2500	37.5kW	86.4kW	126.4kW	

Table 11: Pressure drop across coils

NOMINAL CAPACITY (LITRES)	PRIMARY FLOW RATE l/min		
	15	30	60
400	0.02bar	0.04bar	0.32bar
500	0.02bar	0.04bar	0.32bar
800	0.01bar	0.08bar	0.44bar
1000	0.01bar	0.08bar	0.44bar
1250	0.01bar	0.06bar	0.25bar
1450	0.01bar	0.06bar	0.25bar
2000	0.01bar	0.07bar	0.30bar
2500	0.01bar	0.07bar	0.30bar

Table 12: Indirect heat-up times (based on a 45°C temperature rise)

NOMINAL CAPACITY (LITRES)	PRIMARY FLOW RATE l/min		
	15	30	60
400	43 min	29 min	21 min
500	55 min	38 min	28 min
800	80 min	48 min	32 min
1000	91 min	59 min	39 min
1250	112 min	62 min	40 min
1450	130 min	72 min	50 min
2000	180 min	99 min	48 min
2500	225 min	124 min	62 min

Testing is carried out to BS EN12897:2006

Primary flow rates are based on a flow temperature of 80°C +/- 2°C

Table 13: Maximum kW ratings for Direct Cylinders

NOMINAL CAPACITY (LITRES)	Maximum kW ratings		
	Lower boss	Upper boss	Total kW
400	30	9	39
500	45	12	57
800	45	18	63
1000	45	36	81
1250	54	30	84
1450	54	36	90
2000	54	36	90
2500	54	36	90

Table 14: Water delivered to 40°C (Indirect cylinders only)

NOMINAL CAPACITY (LITRES)	Water delivered to 40°C (Litres)
400	384
500	482
800	776
1000	961
1250	1206
1450	1399
2000	1930
2500	2482

Table 15: Direct heat up times based on maximum kW per cylinder

NOMINAL CAPACITY (LITRES)	Heat-up times		NOMINAL CAPACITY (LITRES)	Heat-up times	
	Maximum kW	Heat up Time (mins)		Maximum kW	Heat up Time (mins)
400	39	32	1250	84	47
500	57	28	1450	90	51
800	63	40	2000	90	70
1000	81	39	2500	90	87

Times based on nominal volume
 Times based on a 45°C temperature rise

Direct heat up times are based on the formula below:

$$\text{Time} = \frac{\text{Volume of water to be heated (litres)} \times \text{Temperature rise}}{\text{kW loading of cylinder} \times 14.3}$$

Worked Example: Volume of water= 500Litres
 Temperature rise = 45°C
 kW loading = 57

$$\text{Time} = \frac{500 \times 45}{57 \times 14.3}$$

$$\text{Time} = \frac{22500}{815.1}$$

Time = 27.6 minutes

Element Allocation Table

Element Kw	94110301		94110302		94110303		94110304		94110305		94110306		94110307		94110308		94110309		
	Upper	Lower	Upper	Lower	Upper	Lower	Upper	Lower	Upper	Lower	Upper	Lower	Upper	Lower	Upper	Lower	Upper	Lower	
Location	6	6	9	9	12	12	18	18	24	24	30	30	36	36	45	45	54	54	
Direct	400	✓	✓	✓	✓	✓	✓	✓	✓	✓	✓	✓	✓	✓	✓	✓	✓	✓	
	500	✓	✓	✓	✓	✓	✓	✓	✓	✓	✓	✓	✓	✓	✓	✓	✓	✓	
	800	✓	✓	✓	✓	✓	✓	✓	✓	✓	✓	✓	✓	✓	✓	✓	✓	✓	
	1000	✓	✓	✓	✓	✓	✓	✓	✓	✓	✓	✓	✓	✓	✓	✓	✓	✓	
	1250	✓	✓	✓	✓	✓	✓	✓	✓	✓	✓	✓	✓	✓	✓	✓	✓	✓	
	1450	✓	✓	✓	✓	✓	✓	✓	✓	✓	✓	✓	✓	✓	✓	✓	✓	✓	✓
	2000	✓	✓	✓	✓	✓	✓	✓	✓	✓	✓	✓	✓	✓	✓	✓	✓	✓	
2500	✓	✓	✓	✓	✓	✓	✓	✓	✓	✓	✓	✓	✓	✓	✓	✓	✓		
Indirect	400	✓	✓	✓	✓	✓	✓	✓	✓	✓	✓	✓	✓	✓	✓	✓	✓	✓	
	500	✓	✓	✓	✓	✓	✓	✓	✓	✓	✓	✓	✓	✓	✓	✓	✓	✓	
	800	✓	✓	✓	✓	✓	✓	✓	✓	✓	✓	✓	✓	✓	✓	✓	✓	✓	
	1000	✓	✓	✓	✓	✓	✓	✓	✓	✓	✓	✓	✓	✓	✓	✓	✓	✓	
	1250	✓	✓	✓	✓	✓	✓	✓	✓	✓	✓	✓	✓	✓	✓	✓	✓	✓	
	1450	✓	✓	✓	✓	✓	✓	✓	✓	✓	✓	✓	✓	✓	✓	✓	✓	✓	
	2000	✓	✓	✓	✓	✓	✓	✓	✓	✓	✓	✓	✓	✓	✓	✓	✓	✓	
2500	✓	✓	✓	✓	✓	✓	✓	✓	✓	✓	✓	✓	✓	✓	✓	✓	✓		

Note:
The element/elements are not factory fitted.

Thermostat/Cut-out

All immersion heaters are fitted with a thermostat which is fitted in the centre of the heater plate and a cut-out which is fitted to the side of the thermostat. These MUST be wired in series with the operating coil circuit of the contactor (not supplied). See figures 4, 5 & 6, below.

Maximum working temperature is 80°C/176°F. In very hard water areas limit to 60/65°C (140/150°F).

For optimal working conditions the thermal cut-out should be set to 80°C and the thermostat should be set to 70°C max. If the thermostat is set above 70°C there could be instances of nuisance tripping of the thermal cut-out.

Notes:

The 2 external contactors must be approved components certified for 10,000 cycles of operation for the contactor controlled by the thermostat and at least 30 for the contactor controlled by the non-self-resetting thermal cut-out.

FIGURE 4: Thermostat and thermal cut-out settings

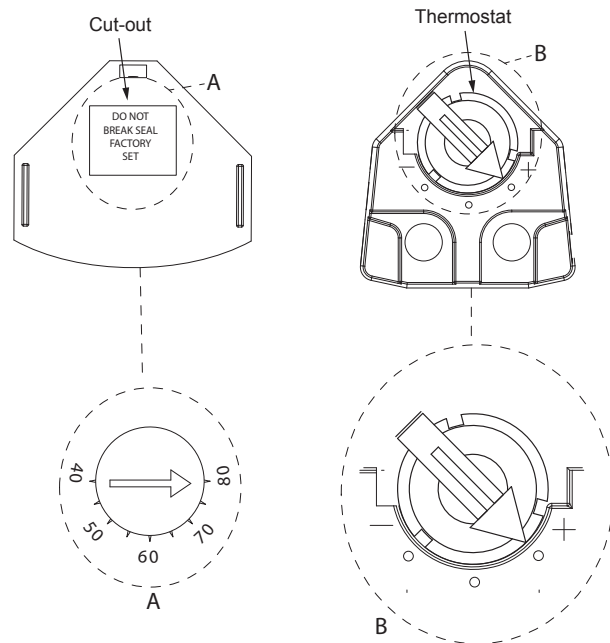
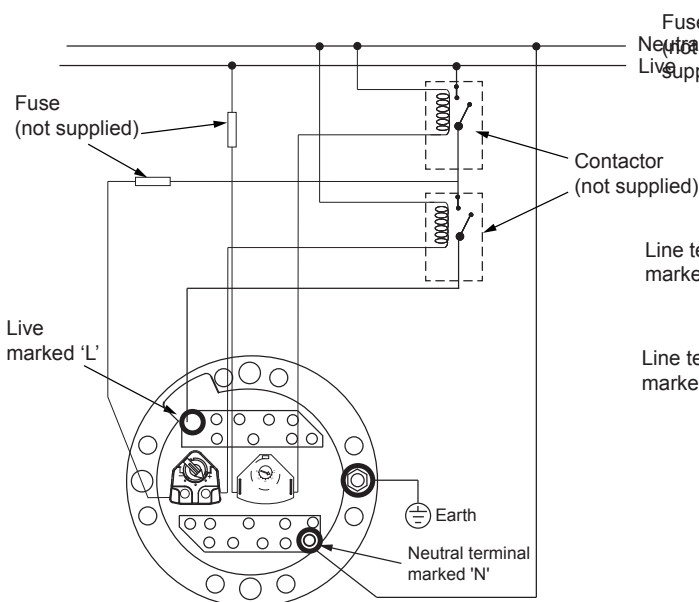
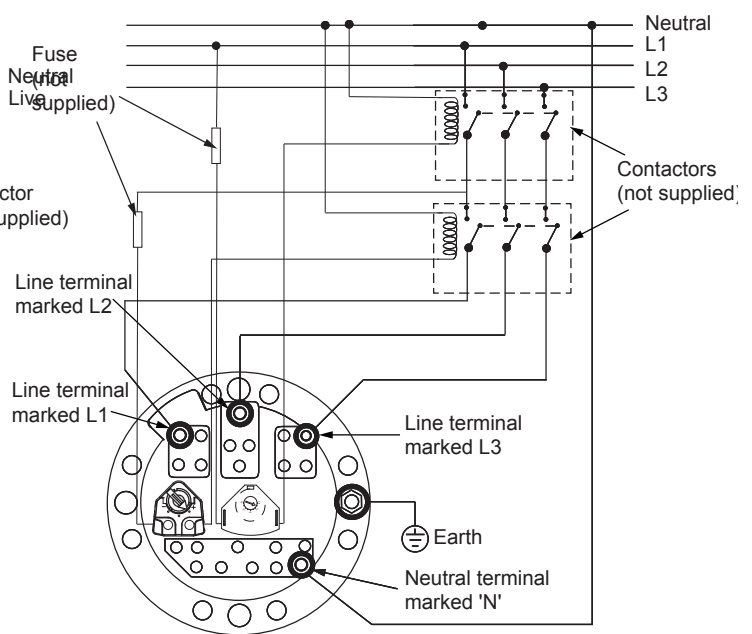

FIGURE 5: Single phase wiring schematic



Typical wiring diagram for single phase heater

FIGURE 6: 3 phase wiring schematic



Typical wiring diagram for three phase heater

Limitations

- The MEGAFLO **Commercial** unvented water heater should not be used in any of the following instances:
- Solid fuel boilers or any other boiler in which the energy input is not under effective thermostatic control unless additional and appropriate safety measures are installed.
- Gravity circulation primaries.
- Steam heating plant unless additional and appropriate safety devices are installed.
- Ascending spray type bidets or any other Class 5 back syphonage risk requiring that a Type AA, AB, AD or AG air gap be employed.
- Water supplies that have either inadequate pressure or where the supply may be intermittent.
- Situations where it is not possible to safely pipe away any discharge from the safety valves.
- Areas where the water consistently contains a high proportion of solids, eg. suspended matter that could block the strainer, unless adequate filtration can be ensured.
- The installation must be carried out in accordance with the relevant requirements of the appropriate Building Regulations: either The Building Regulations (England), The Building Regulations (Scotland) or Building Regulations (Northern Ireland), The Water Fittings Regulations (England and Wales) or Water Byelaws (Scotland).

Water supply

Bear in mind that the mains water supply to the property will be supplying both the hot and cold water requirements simultaneously. It is recommended that the maximum water demand be assessed and the water supply checked to ensure this demand can be met. A minimum flow rate of 100l/min is required for the MEGAFLO **Commercial** range of cylinders

NOTE: A high mains water pressure will not always guarantee high flow rates.

Wherever possible the main supply pipe should be in 28mm. The minimum mains water supply requirements should be 0.15 MPa (1.5 bar) working pressure and minimum 100 litres per minute flow rate. At these values outlet flow rates may be poor if several outlets are used simultaneously, the higher the available pressure and flow rate the better the system performance will be.

The water supply must be of wholesome water quality (Fluid Category 1 as defined by the Water Supply Regulations 1999). The MEGAFLO **Commercial** is to be used for the storage of wholesome water (max. 250mg/l chloride).

Water container:

Duplex stainless steel. 100% pressure tested to 2.25 MPa (22.5 bar).

Installation & Commissioning

General installation

Pipe fittings

All pipe connections to the MEGAFLO **Commercial** are made via BSP female parallel threaded pipe connection directly to the unit.

Cold water supply

A 28mm cold water supply is recommended, however, if a smaller supply exists which provides sufficient flow this may be used. More flow noise may be experienced from small bore pipes due to the increased water velocity through them. A minimum flow rate of 100l/min is required for the MEGAFLO **Commercial** range of cylinders

High flow cold water control pack 1" & 1½" (Low and high pressure)

The control pack consists of a pressure reducing valve with integral strainer, check valve, core unit and expansion relief valve. The pressure settings are adjustable for the low or high pressure valve sets. For the "low" pressure valve set the pressure reducing valve can be set between 1 and 6 bar. For the "high" pressure valve set the pressure can be set between 5 and 10 bar. For optimum performance the following installation instructions should be complied with.

Note: The expansion vessel pressure must be set in accordance with the inlet pressure set on the pressure reducing valve.

Installation:

Cold water supply to be 28mm minimum. Flush supply pipe work before connection to remove all flux and debris prior to fitting the inlet controls. Failure to do this may result in irreparable damage to the controls and will invalidate the warranty.

The pressure reducing valve can be fitted in any orientation to suit the installation as long as it is fitted in the correct flow direction. Check the flow arrows on the side of the body.

The expansion relief valve should be installed with the discharge pipe work in either the horizontal position or facing downwards, if the discharge pipe is facing upwards debris may be deposited on the seat of the valve when in operation.

The blank plastic plugs in the body of the pressure relief valve are pressure gauge connections to enable pressure monitoring to be carried out, should the system develop a fault. It is recommended that these be accessible (the pressure reducing valve has two – only one need be accessible).

Expansion relief discharge pipe work must be connected to a safe visible discharge point via a tundish and the pipe work must have a continuous fall. If site conditions allow, the expansion relief discharge pipe work can be connected to the T&P valve discharge pipe work before the tundish.

Pressure reducing valve:

The pressure reducing valve can be connected anywhere on the cold water mains supply prior to the MEGAFLO **Commercial** unit. There is no requirement to site it close to the unit, it can be located at a point where the mains supply enters the premises if this is more convenient but you must install a non-return valve just after the reducing valve for ease of maintenance.

The pressure reducing valve incorporates an adjustable pressure reducer / strainer. The valve can be fitted in any orientation to suit the installation, however, ensure that the valve is installed with the direction of flow arrows (stamped on the side of the brass body) pointing towards the MEGAFLO **Commercial** heater.

Figure 07: Cold water combination valve (for 400 & 500ltr)

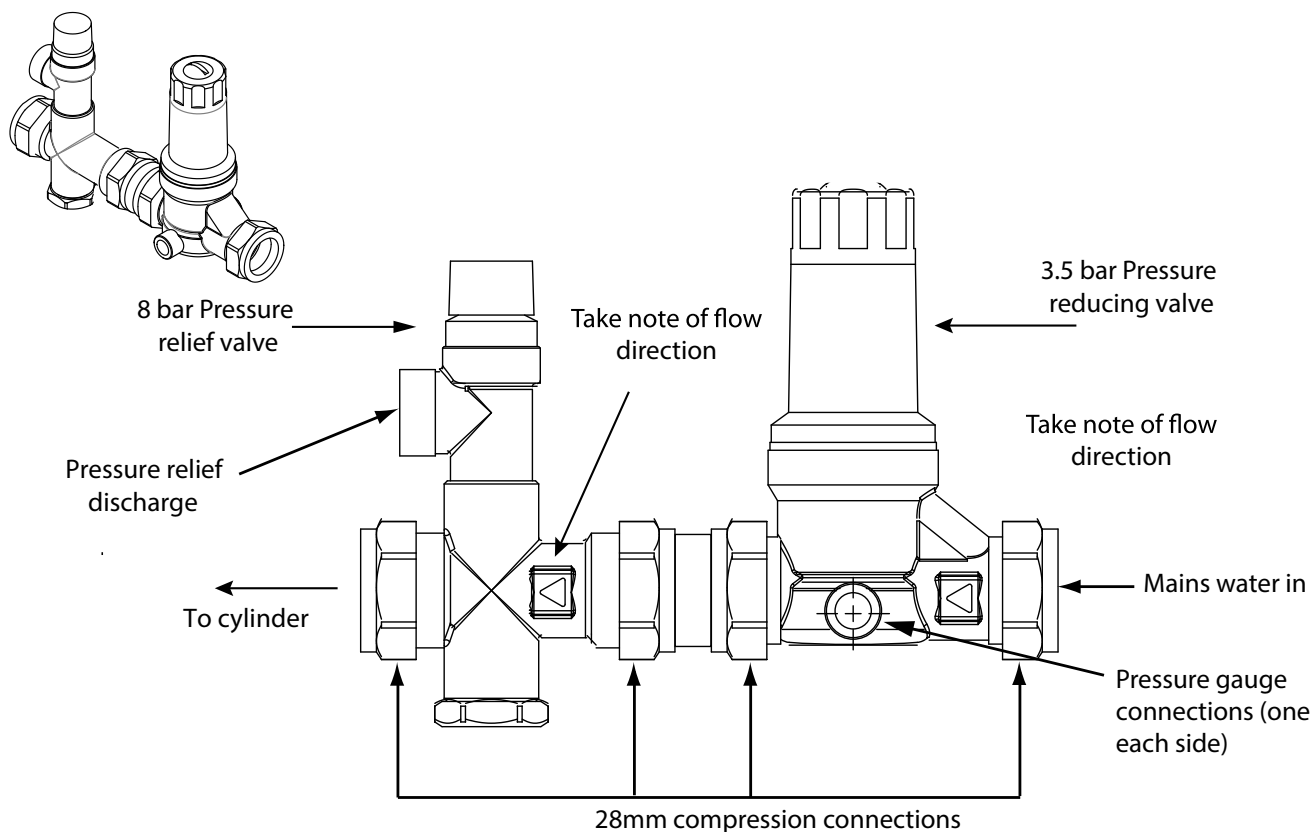
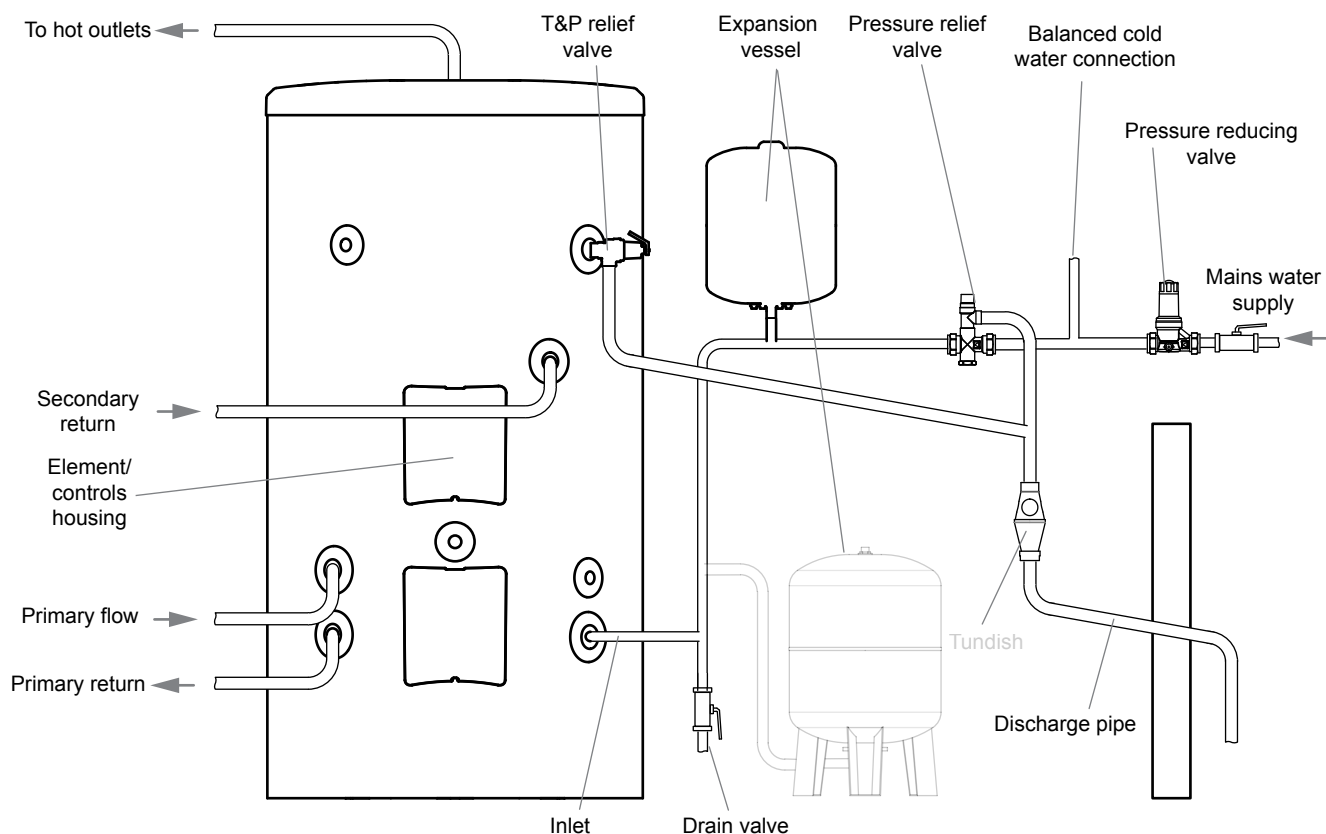

Figure 08: Schematic installation



Pressure Relief Valve

This should be installed between the Pressure Reducing Valve and the MEGAFLO **Commercial** cylinder. Should a balanced pressure cold water draw off supply be required for the cold water outlets, this should be taken off between the Pressure Reducing Valve and Pressure Relief Valve. Branches to drinking water outlets should be taken before the Pressure Relief Valve to avoid the possibility of warm expanded water being drawn from the tap.

Drain valve

It is recommended that the drain valve (supplied) be incorporated into the cold water inlet system, Fig 08, page 16. It is recommended that the outlet point of the drain pipe work be at least 1 metre below the level of the heater (this can be achieved by attaching a hose pipe to the drain valve outlet spigot).

Outlet Pipe work

Ideally the pipe work from the MEGAFLO **Commercial** to the outlet fittings should be in 2" pipe, smaller bore pipe can be used but it could impact on the performance of the unit. Small bore pipe can also be used to suit some taps, but runs should be of minimum length. Pipe sizes may vary due to system design.

Secondary Circulation

If a secondary circulation system is required it is recommended that it be connected to the MEGAFLO **Commercial** as shown in Figure 010, Page 18. The secondary return pipe should be in 28mm pipe and incorporate a check valve to prevent back flow. A suitable WRAS approved bronze circulation pump will be required. On large systems, due to the increase in system water content, it may be necessary to fit additional expansion volume to the secondary system by fitting an external expansion vessel to the circuit. This should be done if the capacity of the secondary circuit exceeds 10 litres.

Pipe capacities (copper)

22mm o/d = 0.38 litres per metre run (10 litres = 26m)

28mm o/d = 0.55 litres per metre run (10 litres = 18m)

35mm o/d = 0.83 litres per metre run (10 litres = 12m)

42mm o/d = 1.23 litres per meter run (10 litres = 8m)

Warnings

1. Under no circumstances should the factory fitted Temperature /Pressure Relief Valve be removed other than by authorised Heatrae Sadia personnel. To do so will invalidate any guarantee or claim.
2. The Cold Water Combination Valve must be fitted to the mains water supply to the MEGAFLO **Commercial** unit.
3. No control or safety valves should be tampered with or used for any other purposes.
4. Water may drip from the discharge pipe of the pressure relief device (Expansion Valve) and this pipe must be left open to atmosphere. The discharge pipe should not be blocked or used for any other purpose.
5. The tundish must be installed so that it is visible to the end user.
6. The tundish, drain valve and motorised valves (indirect units only) must be installed away from any electrical components.
7. No valve should be fitted between the 8 bar or 13 bar pressure relief valve and the MEGAFLO **Commercial** unit.

Figure 09: Pressure reducing valve - 800L - 2500L

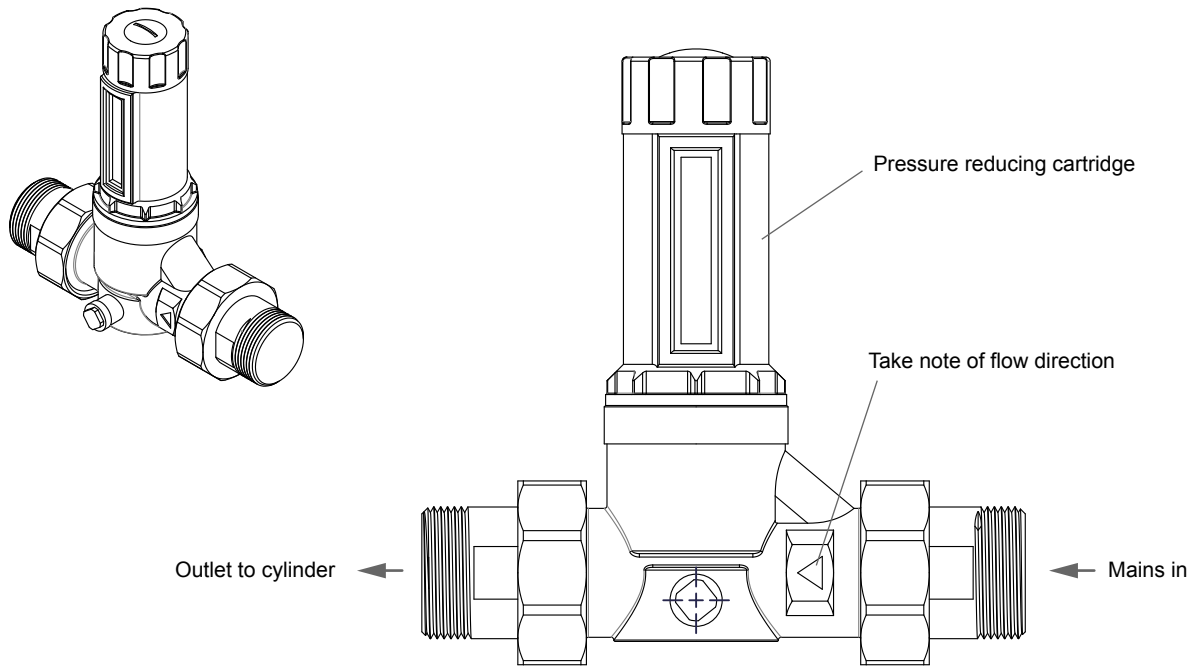

INSTALLATION AND COMMISSIONING (2)

Figure 10: Secondary circulation

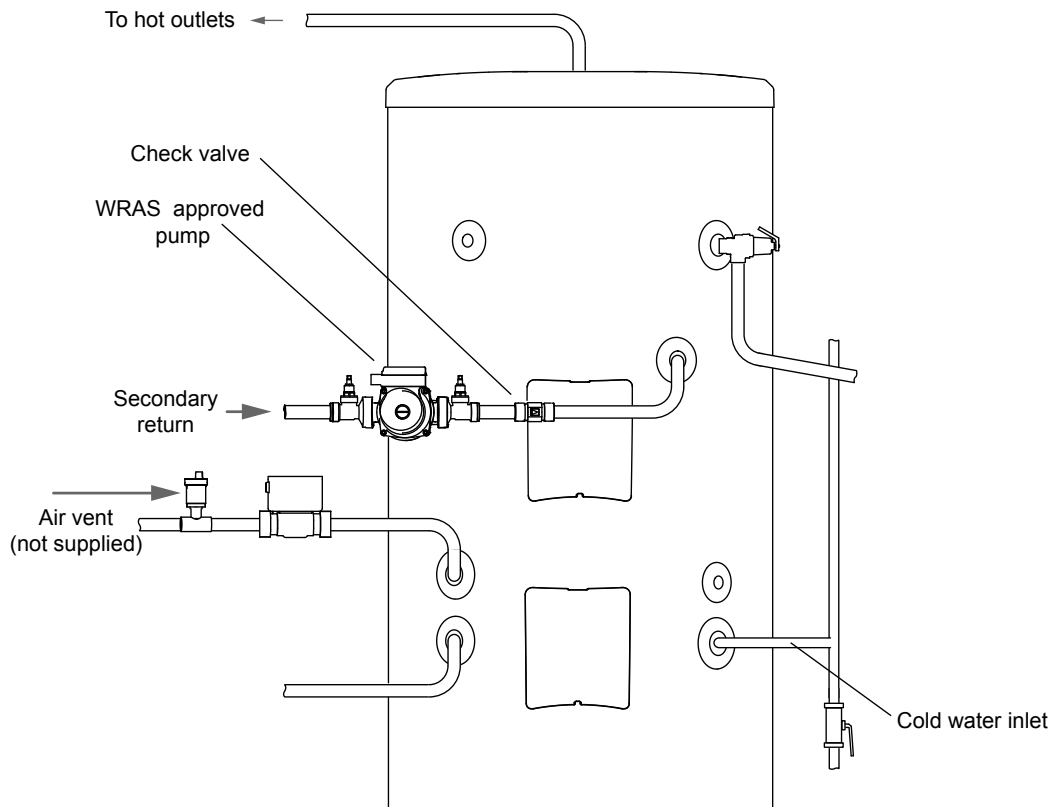

The following extract is taken from the latest G3 Regulations

Discharge pipes from safety devices

Discharge pipe D1

- 3.50 Safety devices such as **temperature relief valves** or **combined temperature and pressure and pressure relief valves** (see paragraphs 3.13 or 3.18) should discharge either directly or by way of a manifold via a short length of metal pipe (D1) to a **tundish**.
- 3.51 The diameter of discharge pipe (D1) should be not less than the nominal outlet size of the **temperature relief valve**.
- 3.52 Where a manifold is used it should be sized to accept and discharge the total discharge from the discharge pipes connected to it.
- 3.53 Where valves other than the **temperature and pressure relief valve** from a single unvented hot water system discharge by way of the same manifold that is used by the safety devices, the manifold should be factory fitted as part of the **hot water storage system unit** or package.

Tundish

- 3.54 The **tundish** should be vertical, located in the same space as the unvented **hot water storage system** and be fitted as close as possible to, and lower than, the valve, with no more than 600mm of pipe between the valve outlet and the **tundish** (see Diagram 1).

Note: To comply with the Water Supply (Water Fittings) Regulations, the **tundish** should incorporate a suitable air gap.

- 3.55 Any discharge should be visible at the **tundish**. In addition, where discharges from safety devices may not be apparent, e.g. in dwellings occupied by people with impaired vision or mobility, consideration should be given to the installation of a suitable safety device to warn when discharge takes place, e.g. electronically operated.

Discharge pipe D2

- 3.56 The discharge pipe (D2) from the **tundish** should:
- (a) have a vertical section of pipe at least 300mm long below the **tundish** before any elbows or bends in the pipework (see Diagram 1); and
 - (b) be installed with a continuous fall thereafter of at least 1 in 200.
- 3.57 The discharge pipe (D2) should be made of:
- (a) metal; or
 - (b) other material that has been demonstrated to be capable of safely withstanding temperatures of the water discharged and is clearly and permanently marked to identify the product and performance standard (e.g. as specified in the relevant part of BS 7291).
- 3.58 The discharge pipe (D2) should be at least one pipe size larger than the nominal outlet size of the safety device unless its total equivalent hydraulic resistance exceeds that of a straight pipe 9m long, i.e. for discharge pipes between 9m and 18m the equivalent resistance length should be at least two sizes larger than the nominal outlet size of the safety device; between 18 and 27m at least 3 sizes larger, and so on; bends must be taken into account in calculating the flow resistance. See Diagram 1, Table 1 and the worked example.
- Note:** An alternative approach for sizing discharge pipes would be to follow Annex D, section D.2 of BS 6700:2006 Specification for design, installation, testing and maintenance of services supplying water for domestic use within buildings and their curtilages.
- 3.59 Where a single common discharge pipe serves more than one system, it should be at least one pipe size larger than the largest individual discharge pipe (D2) to be connected.
- 3.60 The discharge pipe should not be connected to a soil discharge stack unless it can be demonstrated that that the soil discharge stack is capable of safely withstanding temperatures of the water discharged, in which case, it should:
- (a) contain a mechanical seal, not incorporating a water trap, which allows water into the branch pipe without allowing foul air from the drain to be ventilated through the **tundish**;
 - (b) be a separate branch pipe with no **sanitary appliances** connected to it;
 - (c) if plastic pipes are used as branch pipes carrying discharge from a safety device they should be either polybutalene (PB) to Class S of BS 7291-2:2006 or cross linked polyethylene (PE-X) to Class S of BS 7291-3:2006; and
 - (d) be continuously marked with a warning that no **sanitary appliances** should be connected to the pipe.

Note:

1. Plastic pipes should be joined and assembled with fittings appropriate to the circumstances in which they are used as set out in BS EN ISO 1043-1.
2. Where pipes cannot be connected to the stack it may be possible to route a dedicated pipe alongside or in close proximity to the discharge stack.

Termination of discharge pipe

- 3.61 The discharge pipe (D2) from the **tundish** should terminate in a safe place where there is no risk to persons in the vicinity of the discharge.
- 3.62 Examples of acceptable discharge arrangements are:
- b) to a trapped gully with the end of the pipe below a fixed grating and above the water seal;
 - (c) downward discharges at low level; i.e. up to 100mm above external surfaces such as car parks, hard standings, grassed areas etc. are acceptable providing that a wire cage or similar guard is positioned to prevent contact, whilst maintaining visibility; and
 - (d) discharges at high level: e.g. into a metal hopper and metal downpipe with the end of the discharge pipe clearly visible or onto a roof capable of withstanding high temperature discharges of water and 3m from any plastic guttering system that would collect such discharges.
- 3.63 The discharge would consist of high temperature water and steam. Asphalt, roofing felt and non-metallic rainwater goods may be damaged by such discharges.

G3 Requirement

"...there shall be precautions...to ensure that the hot water discharged from safety devices is safely conveyed to where it is visible but will not cause danger to persons in or about the building".

Discharge Pipe work

It is a requirement of Building Regulations that any discharge from an unvented system is conveyed to where it is visible, but will not cause danger to persons in or about the building. The tundish and discharge pipes should be fitted in accordance with the requirements and guidance notes of Building Regulations. Building Regulation G3 Requirements and Guidance section 2 (page 17) are reproduced in the previous sections.

For discharge pipe arrangements not covered by G3 Guidance advice should be sought from your local Building Control Officer. Any discharge pipe connected to the pressure relief devices (Expansion Valve and Temperature / Pressure Relief Valve) must be installed in a continuously downward direction and in a frost free environment.

The water may drip from the discharge pipe of the pressure relief device and that this pipe must be left open to the atmosphere. The pressure relief device is to be operated regularly to remove lime deposits and to verify that it is not blocked.

Worked example of discharge pipe sizing (Taken from Building Regulations 2000, G3, 2010 edition)

The example below is for a G1" temperature relief valve with a discharge pipe (D2) having 4 No. elbows and length of 7m from the tundish to the point of discharge.

From Table 5:

Maximum resistance allowed for a straight length of 35mm copper discharge pipe (D2) from a G1" temperature relief valve is 9m.

Subtract the resistance for 4 No. 35mm elbows at 1.4m each = 5.6m

Therefore the permitted length equates to: 3.4m

3.4m is less than the actual length of 7m therefore calculate the next largest size.

Maximum resistance allowed for a straight length of 42mm pipe (D2) from a G1" temperature relief valve equates to 18m.

Subtract the resistance of 4 No. 42mm elbows at 1.7m each = 6.8m

Therefore the maximum permitted length equates to: 11.2m

As the actual length is 7m, a 42mm (D2) copper pipe will be satisfactory.

Note:

The tundish must be installed away from any electrical devices

Notes:

- 1) Discharge pipe-work D2 can now be a plastic pipe but only pipes that have been tested to a minimum 110°C must be used.
- 2) Discharge pipe D2 can now be plumbed in the soil stack but only soil stacks that can handle temperatures of 99°C or greater should be used.

Table 5 Sizing of copper discharge pipe "D2" for common T&P Relief Valve sizes.

VALVE OUTLET SIZE	MINIMUM SIZE OF DISCHARGE PIPE D1	MINIMUM SIZE OF DISCHARGE PIPE D2 FROM TUNDISH	MAXIMUM RESISTANCE ALLOWED, EXPRESSED AS A LENGTH OF STRAIGHT PIPE (I.E. NO ELBOWS OR BENDS)	RESISTANCE CREATED BY EACH ELBOW OR BEND
G 1/2	15mm	22mm 28mm 35mm	UP TO 9m UP TO 18m UP TO 27m	0.8m 1.0m 1.4m
G 3/4	22mm	28mm 35mm 42mm	UP TO 9m UP TO 18m UP TO 27m	1.0m 1.4m 1.7m
G 1	28mm	35mm 42mm 54mm	UP TO 9m UP TO 18m UP TO 27m	1.4m 1.7m 2.3m

Figure 11: Typical discharge pipe arrangement (Extract from Building Regulations G3 Guidance section 3.5 to 3.63)

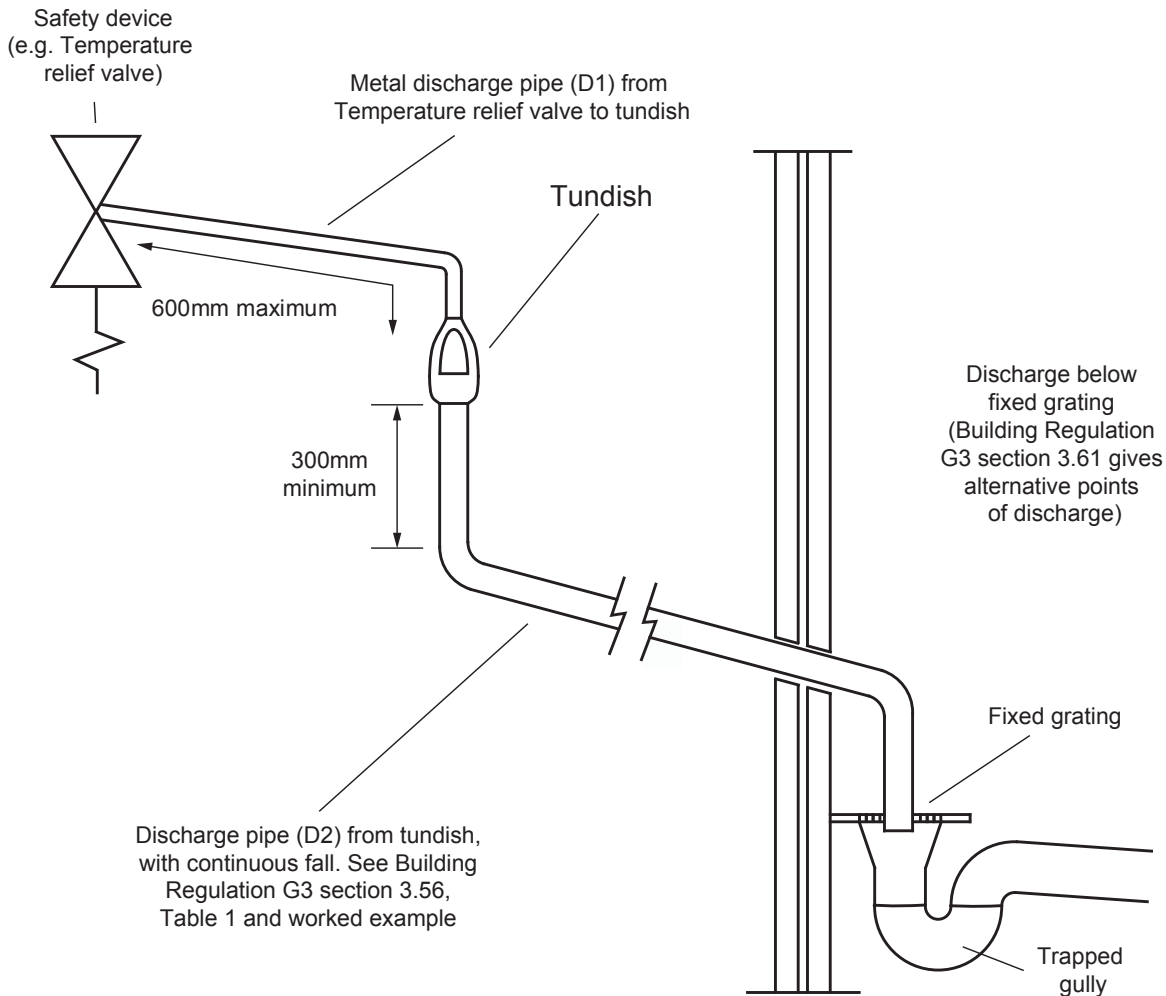

Indirect Model

Boiler Selection

The MEGAFLO **Commercial** Indirect models are suitable for use with most gas or oil fired boilers compatible with unvented systems i.e. fitted with a temperature control thermostat and thermal cut-out. If in doubt consult the boiler manufacturer. Solid fuel boilers or any other boiler in which the energy input is not under effective thermostatic control, unless additional and appropriate safety measures are installed, **SHOULD NOT** be used. The boiler used can either be a sealed system or open vented type, maximum primary circuit pressure 3 bar. The primary flow from the boiler **MUST** be pumped. Gravity circulation will not work due to the special design of the primary heat exchanger. It is recommended that an air bleed point or automatic air vent is incorporated in the primary return pipe work close to the MEGAFLO **Commercial** unit. The boiler flow temperature should usually be set to 82°C (maximum flow temperature to primary heat exchanger 89°C). The boiler cannot be vented through the MEGAFLO **Commercial** unit.

Indirect Thermal Cut-Out And 2-Port Motorised Valve

To comply with Building Regulations, and to prevent the MEGAFLO **Commercial** from overheating the 2-port motorised valve supplied **MUST** be fitted to the primary flow to the indirect coil. It must be wired such that in the event of the cylinder over heating it will close the primary circuit.

Wiring

All electrical wiring should be carried out by a competent electrician and be in accordance with the latest I.E.E. Wiring Regulations BS 7671.

IT IS RECOMMENDED THAT ALL WIRING TO THE IMMERSION HEATERS IS OF A FIXED TYPE.

DO NOT OPERATE THE IMMERSION HEATER(S) UNTIL THE MEGAFLO COMMERCIAL HAS BEEN FILLED WITH WATER.

Safety

**DO NOT BYPASS THE THERMAL CUT-OUT(S) IN ANY CIRCUMSTANCES
DISCONNECT FROM THE MAINS SUPPLY BEFORE REMOVING ANY COVERS
NEVER ATTEMPT TO REPLACE AN IMMERSION HEATER OTHER THAN WITH THE
RECOMMENDED HEATRAE SADIA MEGAFLO COMMERCIAL SPARE PART**

Figure 12: Indirect controls

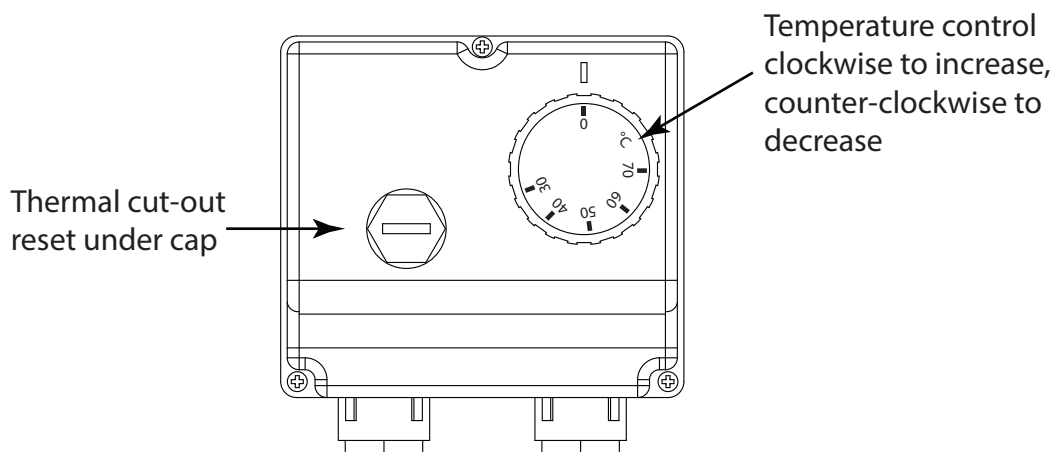
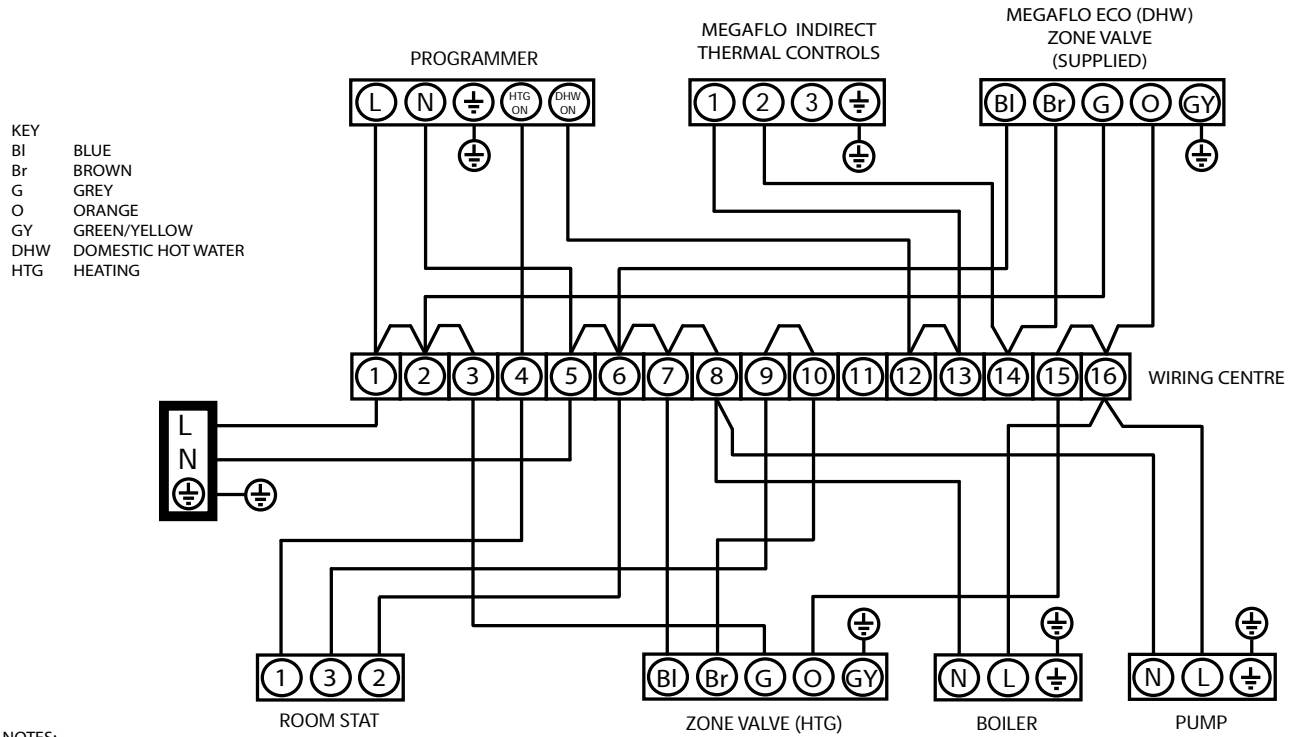
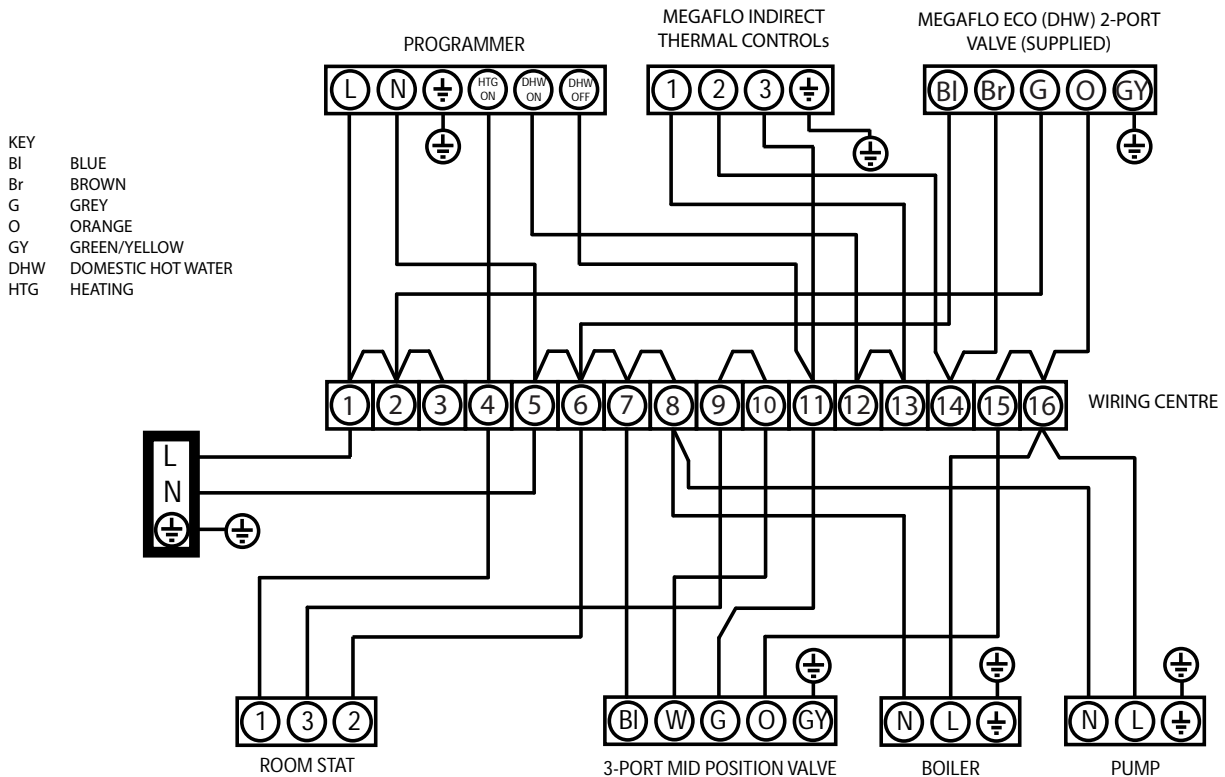

Figure 13: 2 port valve in conjunction with a 3 port mid-position valve system ("Y" Plan)



- NOTES:**
1. A DOUBLE POLE ISOLATING SWITCH MUST BE INSTALLED IN THE MAINS SUPPLY.
 2. ALL EARTH CONNECTIONS MUST BE LINKED BACK TO THE MAINS EARTH SUPPLY.
 3. DO NOT MOUNT WIRING CENTRE ON CYLINDER.
 4. THE ABOVE DIAGRAM IS FOR GUIDANCE ONLY, HEATRAE SADIA ACCEPT NO LIABILITY FOR ANY LOSS OR DAMAGE ARISING FROM ANY ERRORS OR OMISSIONS. THAT MAY BE INADVERTENTLY CONTAINED WITHIN THIS DIAGRAM. THE VARIOUS EQUIPMENT MANUFACTURERS SHOULD BE CONSULTED TO CONFIRM THE CORRECT OPERATION OF THEIR PRODUCTS WITHIN THE SYSTEM.

Figure 14: 2 x 2 port valve system ("S" Plan)



- NOTES:**
1. A DOUBLE POLE ISOLATING SWITCH MUST BE INSTALLED IN THE MAINS SUPPLY.
 2. ALL EARTH CONNECTIONS MUST BE LINKED BACK TO THE MAINS EARTH SUPPLY.

Direct Model

Immersion Heater(s)

The MEGAFLO **Commercial** can be fitted with a selection of single phase and three phase immersion heaters (see Table 13 and element allocation table, page 12 for details). The immersion heaters must be installed in accordance with the installation instructions supplied with the immersion heater (supplied separately)

Warning: Before starting any work on the Megaflo commercial immersion heaters switch off all electrical supplies to such immersion heaters including thermostatic controls, these may be on a separate circuit.

To remove the immersion heater:

Drain down the cylinder before any work is carried out on the Immersion heaters. Remove the immersion heater cover and disconnect all wiring from the Immersion and thermostatic controls. Remove the 8 nuts (or bolts) and withdraw the immersion heater from the cylinder. Take care when lifting the immersion out of the cylinder and work within safe working practices.

Replacement:

Make sure the Immersion heater gasket face is clean and if necessary replace the gasket (spare part number 95607396). Replace the Immersion heater and make sure the 8 nuts (or bolts) are correctly torqued (20Nm or 14.75 ft/lbf) as per the Megaflo commercial immersion heater fitting instructions (36006161). Wire up the immersion heater as per Fig 5, page 13 or Fig 6, page 13 or Megaflo commercial immersion heater fitting instructions. Refill the cylinder and check for leaks. Turn on the supply and set the thermostat temperature to the desired water temperature (60°C - 65°C is recommended).

Wiring (See Figures 4, 5 & 6)

All electrical wiring should be carried out by a competent electrician and be in accordance with the latest I.E.E. Wiring Regulations BS 7671.

DO NOT OPERATE THE IMMERSION HEATER(S) UNTIL THE MEGAFLO Commercial HAS BEEN FILLED WITH WATER.

Operation

See Fig 4, page 13 for details on how to adjust the temperature setting of the heater.

DO NOT BYPASS THE THERMAL CUT-OUT IN ANY CIRCUMSTANCES.

Notes:

Commissioning

Filling and flushing the MEGAFLO Commercial

Ensure that all fittings and immersion heaters are correctly fitted and tightened.

- i) Open a hot tap furthest from the MEGAFLO **Commercial**.
- ii) Open the mains stop cock to fill the unit. When water issues from the tap, allow to run for a few minutes to thoroughly flush through any residue, dirt or swarf, then close tap.
- iii) Open successive hot taps to purge any air from the system.
- iv) Check all connections for leaks and rectify as necessary.
- v) The Strainer housed within the Pressure Reducing Valve should be cleaned to remove any debris that may have been flushed through the main supply pipe.

Check the operation of the Safety Valves

- i) Slowly, manually open for a few seconds, the Temperature and Pressure Relief Valve (T&P Valve) situated on the MEGAFLO **Commercial** unit. Check water discharged runs freely away through the tundish and discharge pipe work. Close valve, ensure water flow stops and valve reseats correctly.
- ii) Repeat for the Pressure Relief Valve.

NOTE: The water discharged may be very hot.

Direct Units

Switch on the electrical supply to the immersion heater(s) and allow the unit to heat up. Check that the thermostat operates correctly. A storage temperature of approx. 60°C is recommended, install and set up immersions as per immersion heater fitting instructions (36006161) . Check that no water is discharged from either the Expansion Valve or Temperature and Pressure Relief Valve during the heating cycle. The thermal cut-out should be set for 85°C max for direct heating

Indirect Units

Fill the indirect (primary) circuit following the boiler manufacturer's commissioning instructions. To ensure the primary heating coil in the MEGAFLO **Commercial** indirect is filled the 2-port motorised valve (supplied) should be manually opened by moving the lever on the motor housing to the MAN OPEN position. When the primary circuit is full return the lever to the AUTO position. Vent any trapped air by opening the air bleed. If necessary the cylinder water temperature can be adjusted by turning the knob located on front of the thermostat housing, see fig 12, page22. The minimum thermostat setting is 30°C. The maximum thermostat setting is 70°C, it is recommended that the water temperature setting is between 60°C and 65°C for optimum working conditions. The thermostat controls contain a thermal cut-out which is set 82°

Benchmark™ Log Book

On completion of the installation and commissioning procedures detailed in this Product Guide the Benchmark™ "Installation, Commissioning and Service Record Log" should be completed and signed off by the competent installer or commissioning engineer in the relevant sections. The various system features, location of system controls, user instructions and what to do in the event of a system failure should be explained to the customer. The customer should then countersign the Benchmark™ commissioning checklist to accept completion. The Service Record should be filled in when any subsequent service or maintenance operation is carried out on the MEGAFLO **Commercial** unit.

Maintenance & Servicing

Maintenance requirements

To ensure the continued optimum performance of the MEGAFLO **Commercial** it should be regularly maintained. This is of particular importance in hard water areas or where the water supply contains particulate matter. Maintenance should be carried out by a competent person and any replacement parts used should be authorised MEGAFLO **Commercial** spare parts. It is recommended that maintenance is carried out every 12 months and includes the checks detailed below.

In hard water areas consideration should be given to periodically descaling the immersion heater elements. To do this the MEGAFLO **Commercial** unit will need to be drained.

Check operation of Safety Valves

Slowly open the Temperature and Pressure Relief Valve by twisting its cap for a few seconds. Check water is discharged and that it flows freely through the tundish and discharge pipe work. Check valve reseats correctly when released.

NOTE: The water discharged may be very hot.

Repeat the procedure for the Pressure Relief Valve.

Inspection

The immersion heater boss can be used as an access for inspecting the cylinder internally.

Clean the strainer

The strainer is incorporated within the Pressure Reducing Valve housing of the Valve. To inspect and clean the strainer:

1. Turn off the isolating valve prior to the Pressure Reducing Valve or the main stop cock to the system.
2. Open the lowest hot tap in the system to relieve the system pressure.
3. Using a spanner unscrew the pressure reducing cartridge and remove the moulded housing. The strainer will be removed with the cartridge.
4. Wash any particulate matter from the strainer under clean running water.
5. Replace the strainer and screw the Pressure Reducing Valve cartridge into the moulded housing.
6. Close hot tap, turn on isolating valve or main stop cock to the system. Check for leaks.

Draining the MEGAFLO Commercial unit

Switch off the electrical supply to the immersion heater(s) and shut down the boiler on indirect units. Turn off the mains water supply to the MEGAFLO **Commercial** unit. Attach a hosepipe to the drain valve having sufficient length to take water to a suitable discharge point below the level of the unit, at least one metre below the unit is recommended. Open hot water tap nearest to the MEGAFLO **Commercial** to relieve the system pressure. Open drain valve. If water fails to drain from the MEGAFLO **Commercial** vent the unit by manually opening the Temperature / Pressure Relief Valve.

Refilling system

DO NOT switch on the immersion heater(s) or boiler until the system has been completely refilled. Close the drain valve. With the hot tap open, turn on mains water supply. When water flows from the hot tap allow to flow for a short while to purge air and to flush through any disturbed particles. Close hot tap and then open successive hot taps in system to purge any air. The electrical supply can now be switched on.

Benchmark™

On completion of any maintenance or service of the MEGAFLO **Commercial**, the Benchmark™ “Installation, Commissioning and Service Record”, Pages 30 & 31, should be filled in to record the actions taken and the date the work was undertaken.

Maintenance

Under normal circumstances the control valves should not require any maintenance. However, annual inspection and/or cleaning of the integral strainer , pressure reducing valve cartridge, expansion relief valve cartridge and seating may be necessary depending on local water conditions.

Pressure reducing valve

Isolate cold water supply and drain system if necessary

Unscrew the retaining nut of the valve. The complete operating mechanism, including the strainer can be removed. Clean the filter mesh and cartridge ensuring that the strainer is correctly located and reassemble the unit.

Expansion Valve

Isolate cold water supply

Unscrew expansion relief cartridge from body and clean the filter mesh and cartridge.

Clean valve seat face and seating – do not scratch or damage either seal face or seating,

Refit in reverse order. Do not over tighten.

Warnings

IF WATER DISCHARGES FROM THE TEMPERATURE / PRESSURE RELIEF VALVE ON THE MEGAFLO COMMERCIAL UNIT REFER TO FAULT FINDING TABLE FIRST FOR GUIDANCE. IF THIS DOES NOT RECTIFY THE FAULT SWITCH OFF ELECTRICAL SUPPLY TO THE IMMERSION HEATER(S) [DIRECT UNITS] OR SHUT DOWN THE BOILER [INDIRECT UNITS]. DO NOT TURN OFF THE WATER SUPPLY. CONTACT A COMPETENT INSTALLER FOR UNVENTED WATER HEATERS TO CHECK THE SYSTEM.

DO NOT TAMPER WITH ANY OF THE SAFETY VALVES FITTED TO THE MEGAFLO COMMERCIAL SYSTEM, IF A FAULT IS SUSPECTED CONTACT A COMPETENT INSTALLER.

Fault finding

The Fault Finding chart will enable operational faults to be identified and their possible causes rectified. Any work carried out on the MEGAFLO **Commercial** unvented water heater and its associated controls **MUST** be carried out by a competent installer for unvented water heating systems. In case of doubt contact the MEGAFLO **Commercial** Service Department.

Table 3: Fault Finding guide

Fault	Possible Cause	Remedy
No hot water flow	Mains water supply off	Check and open stop cock/isolating valve
	Strainer blocked	Turn off water supply, remove strainer and clean
	Cold water combination valve incorrectly fitted	Check and refit as required
Water from hot tap is cold	Direct immersion heater not switched on	Check and switch on
	Direct immersion heater thermal cut-out has operated	Check, reset by pushing button on thermal cut-out
	Indirect programmer set to central heating only	Check, set to domestic hot water programme
	Indirect boiler not working	Check boiler operation. If fault is suspected consult boiler manufacturer's instructions
	Indirect thermal cut-out has operated	Check, reset by pushing button on thermal cut-out Check operation of indirect thermostat
Water discharges from overflow visual indicator (tundish)	INTERMITTENTLY	Incorrect pre-charge pressure for expansion vessel
	CONTINUALLY	Check pressure from pressure reducing valve
		Remove expansion relief cartridge from pressure relief valve and check seating. If necessary fit new cartridge
Water discharges from the T&P relief valve intermittently	Expansion relief valve faulty	Check valve and replace if necessary
Water discharges from the T&P relief valve continually	Thermal control failure NOTE: Water will be very hot	Switch off power to immersion heater(s) and shut down boiler. DO NOT turn off water supply. When discharge stops check all thermal controls, replace if faulty

Servicing

Important

- i) Servicing should only be carried by authorised heateam engineers, Agents or by installers competent in the installation and maintenance of unvented water heating systems.
- ii) Any spare parts used MUST be authorised MEGAFLO **Commercial** parts.
- iii) Disconnect the electrical supply before removing any electrical equipment covers.
- iv) NEVER bypass any thermal controls or operate system without the necessary safety valves.
- v) Water contained in the MEGAFLO **Commercial** unit may be very hot, especially following a thermal control failure. Caution must be taken when drawing water from the unit.

Spares

Spare parts

A full range of spare parts are available for the MEGAFLO **Commercial** range. Refer to the Technical Data label on the unit to identify the model installed and ensure the correct part is ordered.

KEY	DESCRIPTION	SPARES NUMBER
1	IMMERSION HEATER GASKET	95611025
2	BLANKING PLATE KIT	95607396
4	EXPANSION VESSEL 60L 6 BAR	95607445
6	EXPANSION VESSEL 100L 6 BAR	95607458
7	EXPANSION VESSEL 150L 6 BAR	95607461
8	EXPANSION VESSEL 200L 6 BAR	95612723
9	EXPANSION VESSEL 300L 6 BAR	95612724
10	1" INTEGRATED INLET CONTROL VALVE 5-10BAR	95605176
11	ISOLATING BALL VALVE 1"	95605178
12	ISOLATING BALL VALVE 1 1/4"	95605179
13	ISOLATING BALL VALVE 1 1/2"	95605180
14	ISOLATING BALL VALVE 2"	95605181
15	ISOLATING DRAIN VALVE 1"	95605182
16	TUNDISH 1 1/2" x 2"	95607452
17	PRV 1 1/4" SET PRESSURE 1.5 TO 6 BAR MAX IP 16 BAR	95605183
18	PRV 1 1/4" SET PRESSURE 5 TO 10 BAR MAX IP 16 BAR	95605184
19	PRV 1 1/2" SET PRESSURE 1.5 TO 6 BAR MAX IP 16 BAR	95605185
20	PRV 1 1/2" SET PRESSURE 5 TO 10 BAR MAX IP 16 BAR	95605186
21	PRV 2" SET PRESSURE 1.5 TO 6 BAR MAX IP 16 BAR	95605187
22	PRV 2" SET PRESSURE 5 TO 10 BAR MAX IP 16 BAR	95605188
23	SINGLE CHECK VALVE 1 1/4"	95605189
24	SINGLE CHECK VALVE 1 1/2"	95605190
25	SINGLE CHECK VALVE 2"	95605191
26	EXPANSION RELIEF VALVE 1" x 1 1/4" SET PRESSURE 8 BAR	95605192
27	EXPANSION RELIEF VALVE 1" x 1 1/4" SET PRESSURE 13 BAR	95605193
28	EXPANSION RELIEF VALVE 1 1/4" x 1 1/2" SET PRESSURE 8 BAR	95605194
29	EXPANSION RELIEF VALVE 1 1/4" x 1 1/2" SET PRESSURE 13 BAR	95605195
30	TEMPERATURE AND PRESSURE RELIEF VALVE - SET PRESSURE 10 BAR	95605196
31	TEMPERATURE AND PRESSURE RELIEF VALVE - SET PRESSURE 15 BAR	95605197
32	DUAL CONTROL THERMOSTAT	95612650

Spares

KEY	DESCRIPTION	SPARES NUMBER
33	CUT-OUT THERMOSTAT	95612652
34	ROD THERMOSTAT	95980025
35	2 PORT MOTORISED VALVE (DN 32)	95605198
36	2 PORT MOTORISED VALVE (DN 40)	95605199
37	PUMP 3 SPEED CIRCULATION UP 20-30N	95607366
38	PUMP 3 SPEED CIRCULATION UPS 15-50N 130	95607404
39	28mm PUMP ISOLATING VALVE	95605177
40	1/2" BLANKING STAT POCKET	95607690
41	1" BLANKING STAT POCKET	95607691
43	EXPANSION VESSEL 60L 10 BAR	95607446
44	EXPANSION VESSEL 100L 10 BAR	95607459
45	EXPANSION VESSEL 150L 10 BAR	95607462
46	EXPANSION VESSEL 200L 10 BAR	95612725
47	EXPANSION VESSEL 300L 10 BAR	95612726
48	1" INTEGRATED INLET CONTROL VALVE 1-6BAR	95605109
49	OVER TEMPERATURE ROD THERMOSTAT	95980009
50	PUMP ISOLATION VALVE 28mm COMPRESSION TO 1 1/2"	95605110

Accessories

6kW Commercial Immersion - Single phase	94110301
9kW Commercial Immersion - Single phase	94110302
12kW Commercial Immersion - Three phase	94110303
18kW Commercial Immersion - Three phase	94110304
24kW Commercial Immersion - Three phase	94110305
30kW Commercial Immersion - Three phase	94110306
36kW Commercial Immersion - Three phase	94110307
45kW Commercial Immersion - Three phase	94110308
54kW Commercial Immersion - Three phase	94110309
De-Stratification loop kit - 400-500 litre	95970140
De-Stratification loop kit - 800-1450 litre	95970157
De-Stratification loop kit - 2000-2500 litre	95970158
Temperature gauge	95970141
Pressure gauge	95970142
Temperature gauge (calibrated)	95970017
Pressure gauge (calibrated)	95970016

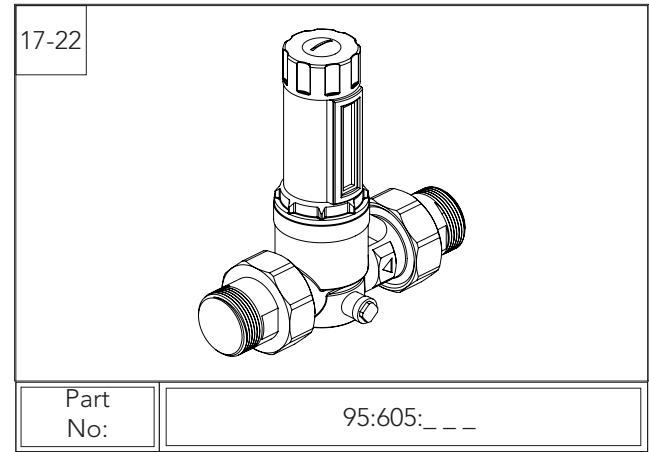
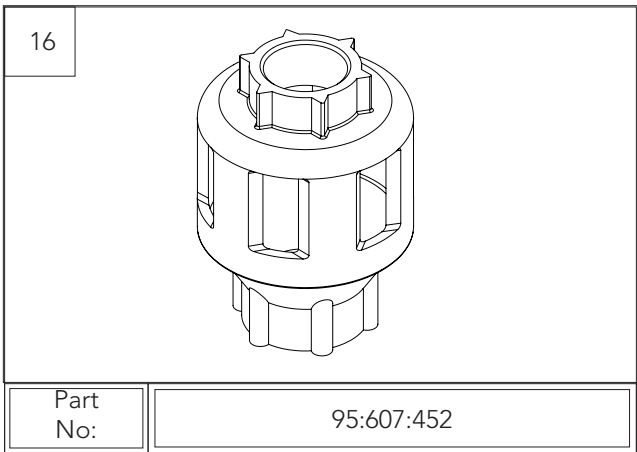
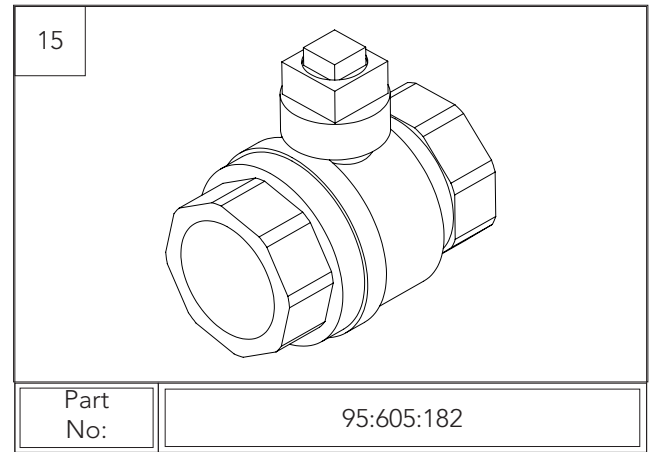
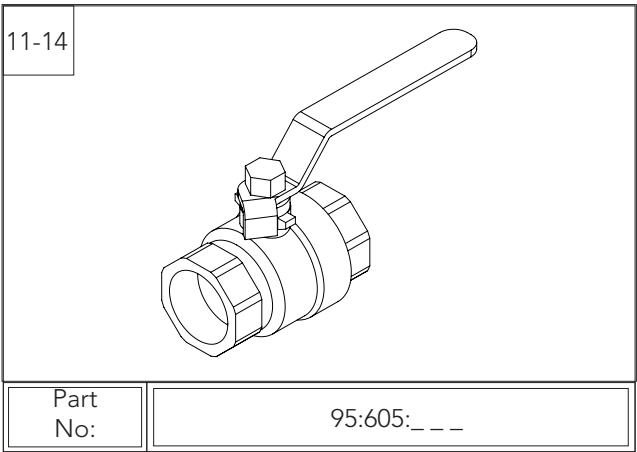
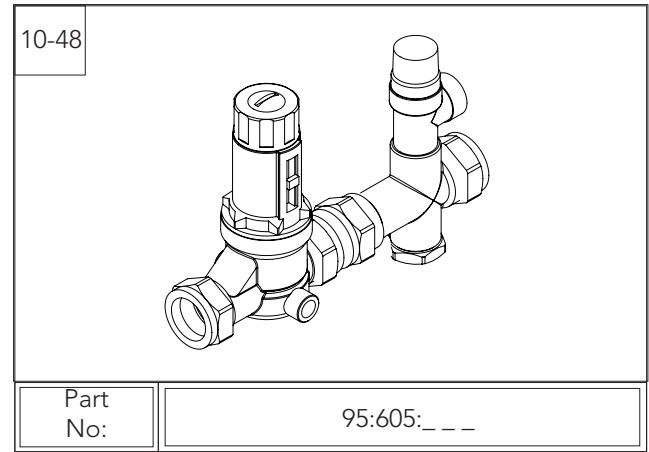
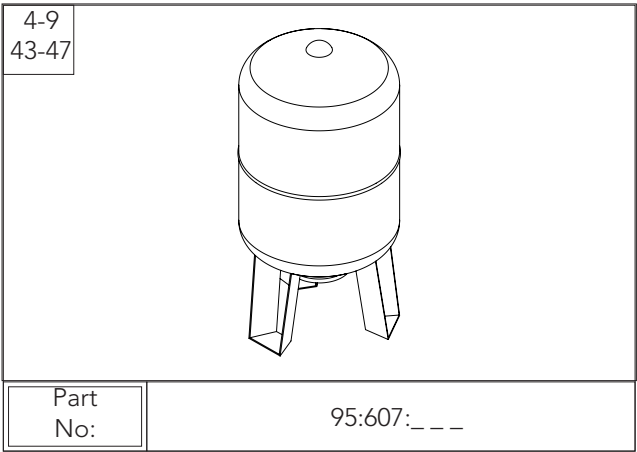
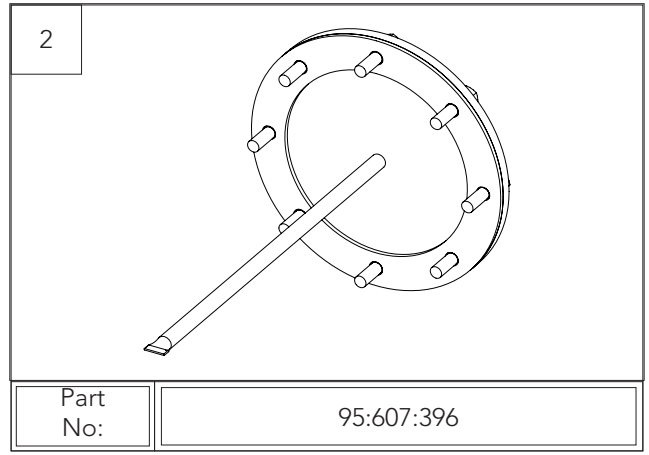
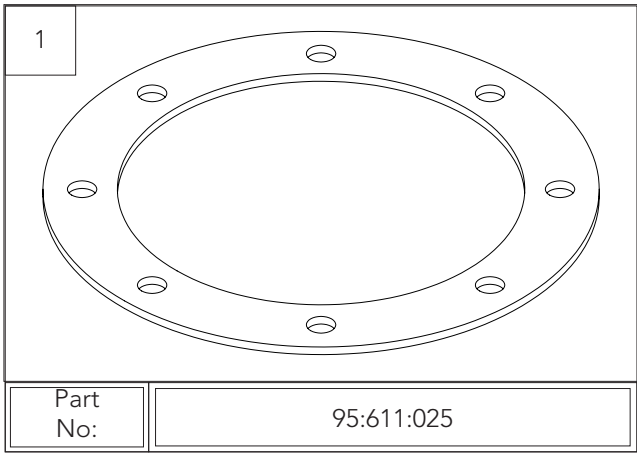

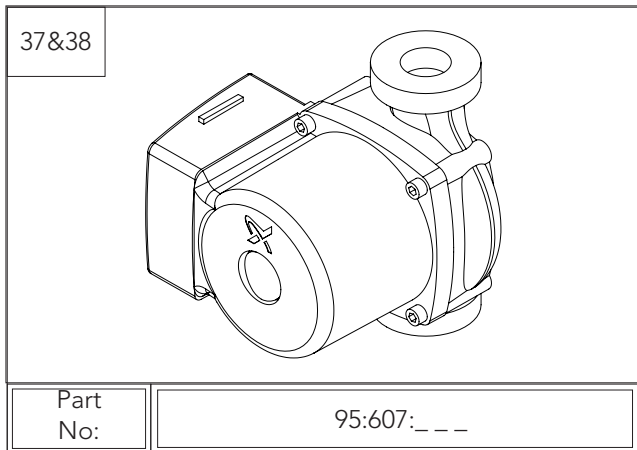
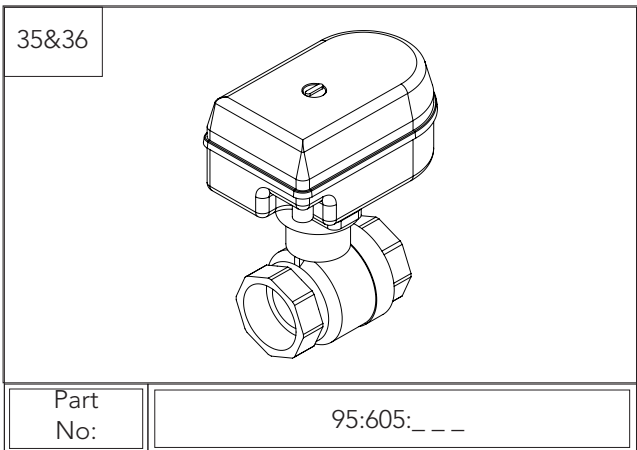
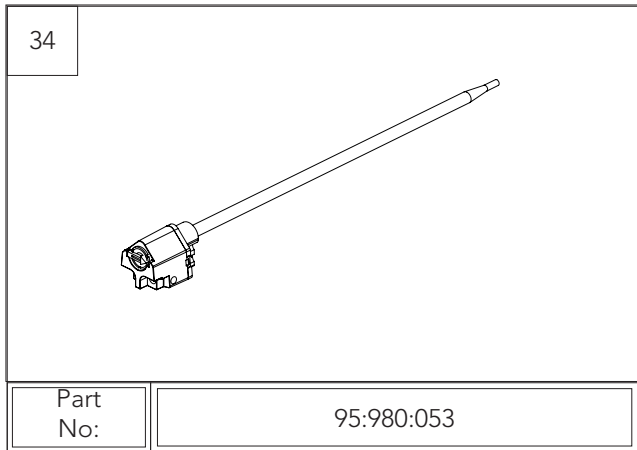
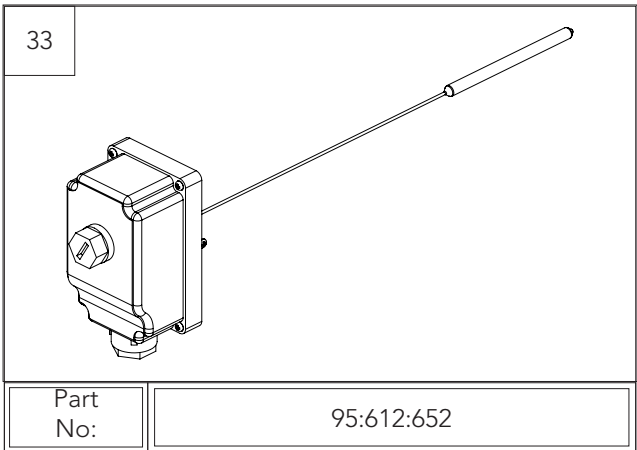
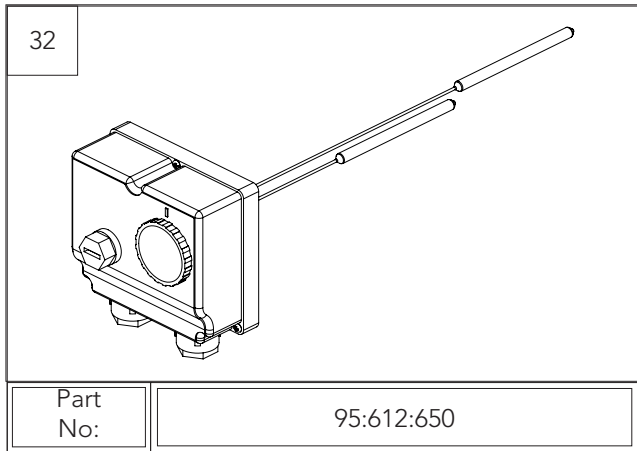
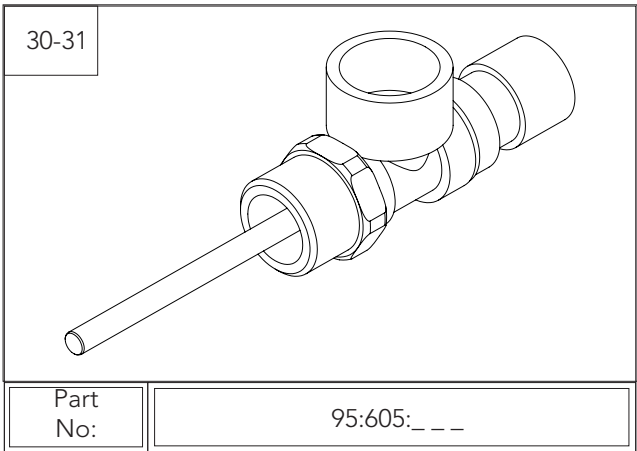
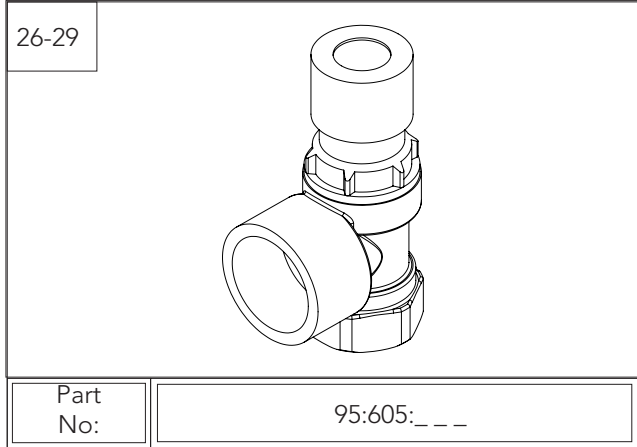
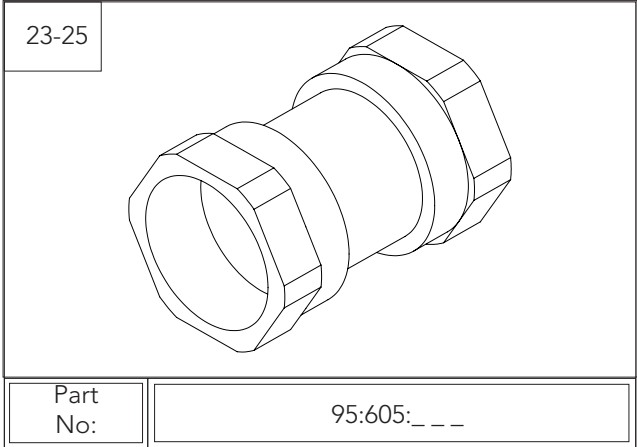

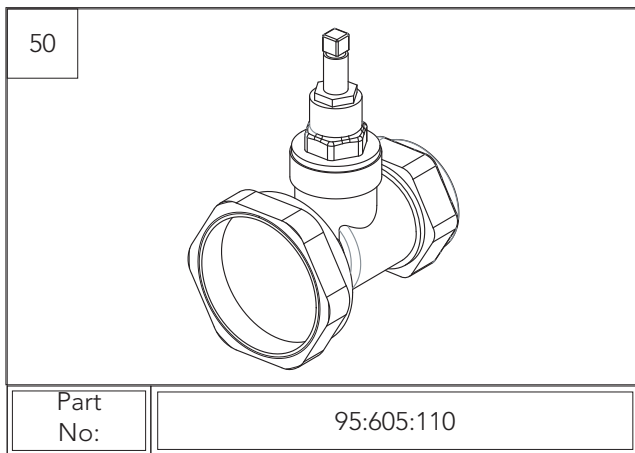
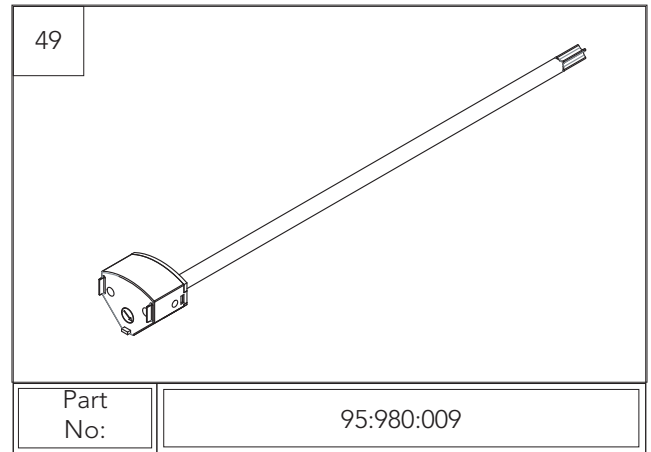
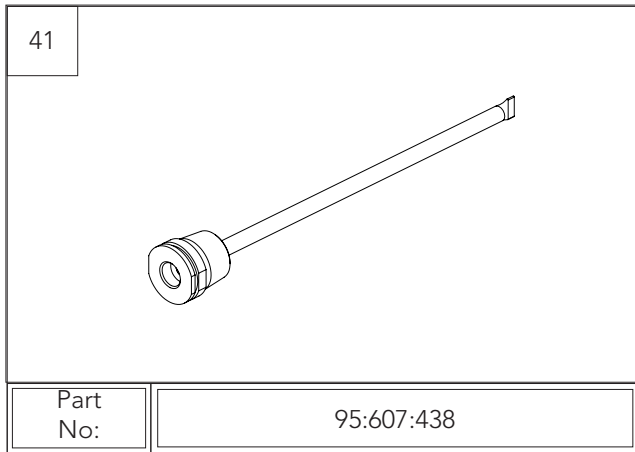
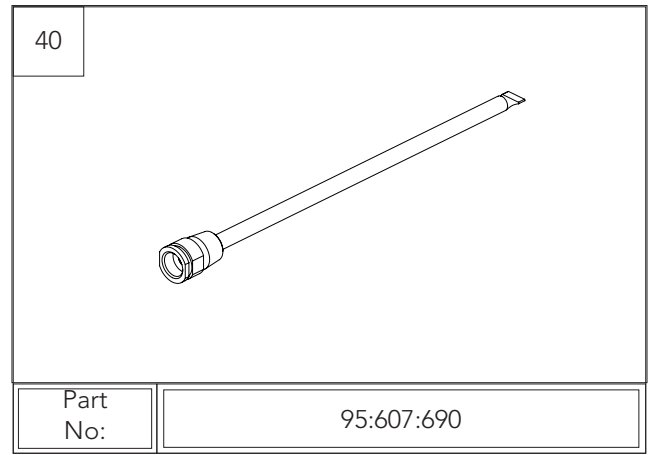
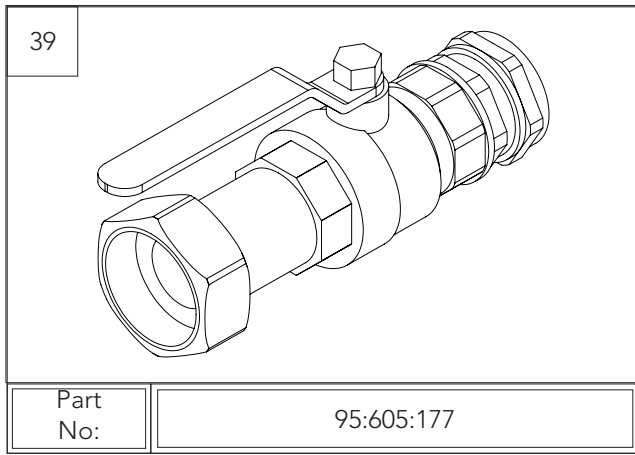

SERVICE RECORD

It is recommended that your hot water system is serviced regularly and that the appropriate Service Record is completed.

Service Provider

Before completing the appropriate Service Record below, please ensure you have carried out the service as described in the manufacturer's instructions.

SERVICE 1 Date _____
Engineer Name _____
Company Name _____
Telephone Number _____
Comments _____

Signature _____

SERVICE 2 Date _____
Engineer Name _____
Company Name _____
Telephone Number _____
Comments _____

Signature _____

SERVICE 3 Date _____
Engineer Name _____
Company Name _____
Telephone Number _____
Comments _____

Signature _____

SERVICE 4 Date _____
Engineer Name _____
Company Name _____
Telephone Number _____
Comments _____

Signature _____

SERVICE 5 Date _____
Engineer Name _____
Company Name _____
Telephone Number _____
Comments _____

Signature _____

SERVICE 6 Date _____
Engineer Name _____
Company Name _____
Telephone Number _____
Comments _____

Signature _____

SERVICE 7 Date _____
Engineer Name _____
Company Name _____
Telephone Number _____
Comments _____

Signature _____

SERVICE 8 Date _____
Engineer Name _____
Company Name _____
Telephone Number _____
Comments _____

Signature _____

SERVICE 9 Date _____
Engineer Name _____
Company Name _____
Telephone Number _____
Comments _____

Signature _____

SERVICE 10 Date _____
Engineer Name _____
Company Name _____
Telephone Number _____
Comments _____

Signature _____

User Guide

Lifetime Guarantee Terms and Conditions

WARNING: Should the factory fitted temperature and pressure relief valve be tampered with or removed your guarantee will be invalidated. Neither the Distributor nor Manufacturer shall be responsible for any consequential damage howsoever caused.

Guarantee Terms

Heatrae Sadia guarantees the MEGAFLO **Commercial** cylinder against faulty manufacture or materials for a period of two years from the date of purchase including parts and labour. This two year guarantee is extended to five years for the cold water control valve and to 25 years (from the date of installation) for the stainless steel inner vessel.

These guarantees are valid provided that:

- The MEGAFLO **Commercial** has been installed by a competent engineer and as per the instructions contained in the installation manual and all relevant Codes of Practice and Regulations in force at the time of installation.
- Any disinfection has been carried out in accordance with BS EN 806-5:2012
- Should the factory fitted temperature and pressure relief valve be tampered with or removed your guarantee will be invalidated.
- The MEGAFLO **Commercial** unit has not been modified in anyway other than by heateam approved engineers.
- The MEGAFLO **Commercial** unit has only been used for the storage of wholesome sanitary water (max 250mg/l chloride).
- Only stainless steel dummy plugs are to be used.
- The MEGAFLO **Commercial** unit has not been subjected to excessive pressure beyond the guidelines detailed in the installation instructions.
- The MEGAFLO **Commercial** unit has not been subjected to frost, nor has it been tampered with or been subject to misuse or neglect.
- No factory fitted parts have been removed for un-authorized repair or replacement
- Regular maintenance has been carried out by a competent person in accordance with the requirements set in the maintenance section of the installation manual and any replacement parts used should be approved MEGAFLO **Commercial** spare parts.
- The guarantee is not valid outside of the United Kingdom.

The warranty does NOT cover:

Consequential damages or profit loss which may arise from a defect.

Warranty claims have no delaying effect on the payment dates and other demands

Your MEGAFLO **Commercial** warranty covers you for a direct replacement and labour in the event that the unit fails prematurely as a result of a proved manufacturing defect.

In order that this can be achieved, full access to replace the unit is essential. If it is found that access can not be achieved the warranty will be limited to the replacement of the unit only and subsequent labour charges would not be met under the warranty.

For installations outside of the United Kingdom, please contact either the Megaflo Export Department on Tel: +44 1603 420271 or Baxi International on Tel: +44 1926 478323 for further details of the guarantee terms and conditions applicable. This guarantee does not affect your statutory rights. The unit is not guaranteed against damage due to frost. This guarantee does not affect your statutory rights.

The Environment

This product is made from many recyclable materials, therefore at the end of its useful life it should be disposed of at a Local Authority Recycling Centre in order to realise the full environmental benefits. Insulation is by means of an approved HCFC/CFC free polyurethane foam.

Spares Stockists

megafloservice@heateam.co.uk
Electric Water Heating Co.
2 Horsecroft Place
Pinnacles
Harlow
Essex
CM19 5BT
Tel: 0845 0553811
E-Mail: sales@ewh.co.uk

SPD
Special Product Division
Units 9 & 10
Hexagon Business Centre
Springfield Road
Hayes
Middlesex
UB40 0TY
Tel: 0208 5730574

Parts Center
Network 65 Business Park
Bentley Wood Way
Burnley
Lancashire
BB11 5ST
Telephone
0844 8711535 (option 5)
Facsimile
0844 8711528
E mail
Tel: 01282 834403
www.partscenter.co.uk

Newey & Eyre
Specialist Products Division
Please Contact your Local Branch

UK Spares Ltd
Unit 1155
Aztec West
Almondsbury
Bristol
BS32 4TF
Tel: 01454 620500

William Wilson Ltd
Unit 3A
780 South Street
Whiteinch
Glasgow
G14 0SY
Tel: 0141 434 1530



Customer Service

Telephone

0845 070 1058

Facsimile

0845 070 1059

E mail

heateam.commercial@baxicommercialdivision.com

Megaflo

Hurricane Way

Norwich

Norfolk

NR6 6EA

PART OF BDR THERMEA © 2011