

+ INSTALLATION AND SERVICING

LOGIC SYSTEM
15IE 18IE 24IE 30IE

For Users Guide see reverse of book



For details of document amendments, refer to page 3

When replacing any part on this appliance, use only spare parts that you can be assured conform to the safety and performance specification that we require. Do not use reconditioned or copy parts that have not been clearly authorised by Ideal.

For the very latest copy of literature for specification and maintenance practices visit our website www.idealboilers.com where you can download the relevant information in PDF format.



NOTES FOR THE INSTALLER

**FOR ANY TECHNICAL QUERIES PLEASE RING THE
IDEAL INSTALLER/TECHNICAL HELPLINE : +44 (0)1482 498704**

NOTE. BOILER RESET PROCEDURE -

To reset boiler, turn mode knob to reset position and immediately turn knob back to required setting.
The boiler will repeat the ignition sequence if a heat demand is present.

DOCUMENT AMENDMENTS

Relevant Installation changes implemented in this book from Mod Level..... **A04** (Jan 14) to **A05** (May 14)

Cover Pages

Re-brand outer covers

GENERAL

Table 1 - General Data

Ideal Logic System IE			15IE	18IE	24IE	30IE
Gas supply			2H - G20 - 20mbar			
Gas Supply Connection			15mm copper compression			
Injector Size	(mm)		4.15	4.15	4.15	4.65
Flow Connection	Central Heating		22mm copper compression			
Return Connection	Central Heating		22mm copper compression			
Flue Terminal Diameter	mm (in)		100 (4)			
Average Flue Temp-Mass Flow Rate			56°C - 6g/s	58°C - 8 g/s	63°C - 10g/s	69°C - 13g/s
Maximum Working Pressure (Sealed Systems)	bar (lb/in ²)		2.5 (36.3)			
Electrical Supply			230 V ~ 50 Hz.			
Power Consumption	W		126	131	146	152
Fuse Rating			External : 3A Internal : T4H HRC L250 V			
Water content	litre (gal)		1.2 (0.26)			
Packaged Weight	kg (lb)		34.4 (76)	34.4 (76)	34.4 (76)	34.4 (76)
Maximum Installation Weight	kg (lb)		28 (61.7)	28 (61.7)	28 (61.7)	28 (61.7)
Boiler Casing Size	Height	mm (in)	700 (27.5)			
	Width	mm (in)	395 (15.5)			
	Depth	mm (in)	278 (11)			

Table 2 - Performance Data - Central Heating

			15IE		18IE		24IE		30IE	
			MIN	MAX	MIN	MAX	MIN	MAX	MIN	MAX
Boiler Input :										
Boiler Input 'Q'	Nett CV	kW	4.9	15.1	4.9	18.1	4.9	24.3	6.1	30.4
		(Btu/h)	(16,600)	(51,520)	(16,600)	(61,800)	(16,600)	(82,900)	(20,700)	(103,600)
	Gross CV	kW	5.4	16.6	5.4	20.1	5.4	27.0	6.7	33.7
		(Btu/h)	(18,400)	(56,800)	(18,400)	(68,600)	(18,400)	(92,000)	(23,000)	(115,000)
Gas Consumption		m ³ /h	0.500	1.537	0.500	1.872	0.500	2.512	0.622	3.135
		(ft ³ /h)	(17.8)	(54.7)	(17.8)	(66.1)	(17.8)	(89)	(22)	(111)
Boiler Output :										
Non Condensing kW			4.8	15.0	4.8	18.0	4.8	24.2	6.1	30.3
70°C Mean Water temp.		(Btu/h)	(16,500)	(51,300)	(16,500)	(61,600)	(16,500)	(82,600)	(20,700)	(103,300)
Condensing kW			5.1	15.9	5.1	19.1	5.1	25.6	6.4	31.0
40°C Mean Water temp.		(Btu/h)	(17,500)	(54,250)	(17,500)	(65,100)	(17,500)	(87,400)	(21,800)	(105,800)
Seasonal efficiency* SEDBUK 2005			91.1%		91%		91%		91.1%	
Seasonal efficiency* SEDBUK 2009			89.3		89.2%		89.5%		89.6%	
NOx Classification			CLASS 5							

* The value is used in the UK Government's Standard Assessment Procedure (SAP) for energy rating of dwellings. The test data from which it has been calculated have been certified by a notified body.

Note. Gas consumption is calculated using a calorific value of 38.7 MJ/m³ (1038 Btu/ft³) gross or 34.9 MJ/m³ (935 Btu/ft³) nett

To obtain the gas consumption at a different calorific value:

- a. **For l/s** - divide the gross heat input (kW) by the gross C.V. of the gas (MJ/m³)
- b. **For ft³/h** - divide the gross heat input (Btu/h) by the gross C.V. of the gas (Btu/ft³)
- c. **For m³/h** - multiply l/s by 3.6.

Key to symbols

GB = United Kingdom **IE** = Ireland (Countries of destination)

PMS = Maximum operating pressure of water

C₁₃ C₃₃ C₅₃ = A room sealed appliance designed for connection via ducts to a horizontal or vertical terminal, which admits fresh air to the burner and discharges the products of combustion to the outside through orifices which, in this case, are concentric. The fan is up stream of the combustion chamber.

I_{2H} = An appliance designed for use on 2nd Family gas, Group H only.

GENERAL

IDEAL Logic System IE

Natural Gas only

Boiler size	G.C. Appliance No. (Benchmark No.)	PI No.
15IE	41-750-44	86 CL 08
18IE	41-750-45	86 CL 08
24IE	41-750-46	86 CL 08
30IE	41-750-47	86 CL 08

Destination Country: GB, IE

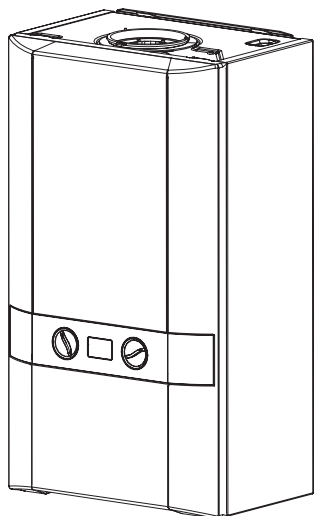

CONTENTS

Air Supply	9
Benchmark Commissioning Checklist	56
Boiler Clearances	10
Boiler Exploded Diagram	13
Condensate Drain	24,25
Commissioning & Testing	30
Electrical Connections	26
Electrical Supply	9
Fault Finding	48-52
Flue Fitting	17
Flue Installation	8
Gas Safety Regulations	7
Gas Supply	8
Initial Lighting	31
Installation	13-32
Pump	46
Safe Handling	6
Servicing	33-47
Spare Parts Info	53
Thermostatic Radiator Valves	9
Water and Systems	9,11-12
Water Connections	10,26
Water Treatment	12
Wiring Diagram	29

For GB, to comply with Building Regulations Part L1 (Part 6 in Scotland) the boiler should be fitted in accordance with the manufacturer's instructions. Self-certification that the boiler has been installed to comply with Building Regulations can be demonstrated by completing and signing the Benchmark Commissioning Checklist.

Before installing this boiler, read the Code of Practice sheet at the rear of this book.

BENCHMARK COMMISSIONING CHECKLIST DETAILS

Boiler	Page	Page	
Make and model.....	5	Burner operating pressure	n/a
Appliance serial no. on data badge	Front Cover	Central heating flow temp.	measure and record
SEDBUK No. %.....	4	Central heating return temp.	measure and record
Controls		For combination boilers only	
Time and temperature control to heating	27	Scale reducer	12
Time and temperature control to hot water	N/A	<i>Hot water mode</i>	
Heating zone valves.....	27	Heat input.....	to be calculated
TRV's.....	9	Max. operating burner pressure	n/a
Auto bypass	9	Max. operating water pressure.....	measure & record
Boiler interlock.....	9	Cold water inlet temp	measure & record
For	all boilers	Hot water outlet temp	measure & record
Flushing to BS.7593.....	12	Water flow rate at max. setting.....	measure & record
Inhibitor	12	For condensing boilers only	
<i>Central heating mode</i>		Condensate drain.....	24,25
Heat input.....	to be calculated	For all boilers: complete, sign & hand over to customer	

For assistance see Technical Helpline on the back page

NOTE TO THE INSTALLER: COMPLETE THE BENCHMARK COMMISSIONING CHECKLIST AND LEAVE THESE INSTRUCTIONS WITH APPLIANCE



INTRODUCTION

The **Logic System IE** range of boilers are wall mounted, full sequence, automatic spark ignition, low water content, fanned flue, high efficiency, condensing, system gas boilers.

Note. *Due to the high efficiency of the boiler a plume of water vapour will form at the terminal during operation.*

Central heating (CH) output is fully modulating with a range of:

15	4.8 to 15kW (16,500 to 51,300 Btu/h)
18	4.8 to 18kW (16,500 to 61,600 Btu/h)
24	4.8 to 24.2kW (16,500 to 82,600 Btu/h)
30	6.1 to 30.3kW (20,700 to 103,300 Btu/h)

The boiler is supplied fully assembled with circulating pump, pressure gauge, safety valve and CH expansion vessel.

A variable CH temperature control is fitted on the user control.

The boiler includes as standard:

- Boiler frost protection
- Daily pump exercise.

Note. The appliance must be wired with a permanent live supply or the boiler frost protection will not operate.

The boiler warranty will be invalid if this requirement is not complied with.

The boiler casing is of white painted mild steel.

The boiler temperature control is visibly located in the control panel on the front of the boiler.

The heat exchanger is manufactured from cast aluminium.

The boiler is suitable for connection to fully pumped, sealed heating systems ONLY. Adequate arrangements for completely draining the system by provision of drain cocks MUST be provided in the installation pipework.

Pipework from the boiler is routed downwards.

OPERATION

When there is a demand for CH, the heating system is supplied at the selected temperature of between 30°C and 80°C.

The boiler features a comprehensive diagnostic system which gives detailed information on the boiler status when operating, and performance of key components to aid commissioning and fault finding.

SAFE HANDLING

This boiler may require 2 or more operatives to move it to its installation site, remove it from its packaging base and during movement into its installation location. Manoeuvring the boiler may include the use of a sack truck and involve lifting, pushing and pulling.

Caution should be exercised during these operations.

Operatives should be knowledgeable in handling techniques when performing these tasks and the following precautions should be considered:

- Grip the boiler at the base.
- Be physically capable.
- Use personal protective equipment as appropriate, e.g. gloves, safety footwear.

During all manoeuvres and handling actions, every attempt should be made to ensure the following unless unavoidable and/or the weight is light.

- Keep back straight.
- Avoid twisting at the waist.
- Avoid upper body/top heavy bending.
- Always grip with the palm of the hand.
- Use designated hand holds.
- Keep load as close to the body as possible.
- Always use assistance if required.

OPTIONAL EXTRA KITS

- **Horizontal Flue Terminal** (600mm long)
- **Horizontal Flue Terminal** (1000mm long)
- **Horizontal Flue Telescopic**
- **Flue Extension Ducts** (1000mm long)
 - 15-up to 9m
 - 18-up to 9m
 - 24-up to 9m
 - 30-up to 8m
- **90° Elbow Kit** (maximum per installation).
 - 15-up to 6 elbows
 - 18-up to 6 elbows
 - 24-up to 6 elbows
 - 30-up to 6 elbows
- **45° Elbow Kit** (maximum per installation).
 - 15-up to 6 elbows
 - 18-up to 6 elbows
 - 24-up to 6 elbows
 - 30-up to 6 elbows
- **Roof Flue Kit** (to a maximum of 7.5m)
- **Powered Vertical Flue Kit** (5m primary and 17m secondary is a typical maximum length. For alternative details refer to Powered Vertical Instructions)
- **Flue Finishing Kit**
- **High Level Flue Outlet Kit**
- **Flue Deflector Kit**
- **Adjustable Flue Support Bracket**
- **Balcony Flue Kit**
- **Raised Horizontal Flue Outlet Kit**
- **Concentric Flue Screw Retaining Kit**
- **Weather Collar (Universal)**
- **Weather Collar (Flat Roof)**
- **Stand-Off Kit**
- **Stand-Off Kit (inc. pipes)**
- **Pre-Piping Frame Kit**
- **Condensate Pump Kit**
- **Weather Compensation Kit**
- **Security Bracket Kit**
- **PRV Wall Outlet Kit**
- **Pressure Gauge Extension Kit**

SAFETY

Current Gas Safety (installation and use) regulations or rules in force:

The appliance is suitable only for installation in GB and IE and should be installed in accordance with the rules in force.

In GB, the installation must be carried out by a Gas Safe Registered Engineer. It must be carried out in accordance with the relevant requirements of the:

- Gas Safety (Installation and Use) Regulations
- The appropriate Building Regulations either The Building Regulations, The Building Regulations (Scotland), Building Regulations (Northern Ireland).
- The Water Fittings Regulations or Water byelaws in Scotland.
- The Current I.E.E. Wiring Regulations.

Where no specific instructions are given, reference should be made to the relevant British Standard Code of Practice.

In IE, the installation must be carried out by a Registered Gas Installer (RGII) and installed in accordance with the current edition of I.S.813 "Domestic Gas Installations", the current Building Regulations and reference should be made to the current ETCI rules for electrical installation.

Detailed recommendations are contained in the following British Standard Codes of Practice:

- BS. 5440:1** Flues (for gas appliances of rated input not exceeding 70 kW).
- BS. 5440:2** Ventilation (for gas appliances of rated input not exceeding 70 kW).
- BSEN. 12828:2003** Heating Systems in buildings: Design for water based heating systems.
- BSEN 12831:2003** Heating Systems in buildings: Method for calculation of the design heat load.
- BSEN 14336:2004** Heating Systems in buildings: Installation and commissioning of water based heating systems.
- BS. 5546** Installation of gas hot water supplies for domestic purposes (2nd Family Gases)
- BS. 6798** Installation of gas fired hot water boilers of rated input not exceeding 70 kW.
- BS. 6891** Low pressure installation pipes.

Health & Safety Document No. 635.

The Electricity at Work Regulations, 1989.

The manufacturer's notes must NOT be taken, in any way, as overriding statutory obligations.

IMPORTANT. These appliances are CE certificated for safety and performance. It is, therefore, important that no external control devices, e.g. flue dampers, economisers etc., are directly connected to these appliances unless covered by these Installation and Servicing Instructions or as otherwise recommended by **Ideal Stelrad Group** in writing. If in doubt please enquire.

Any direct connection of a control device not approved by **Ideal Stelrad Group** could invalidate the certification and the normal appliance warranty. It could also infringe the Gas Safety Regulations and the above regulations.

SAFE HANDLING OF SUBSTANCES

No asbestos, mercury or CFCs are included in any part of the boiler or its manufacture.

LOCATION OF BOILER

The boiler must be installed on a flat and vertical internal wall, capable of adequately supporting the weight of the boiler and any ancillary equipment.

The boiler may be fitted on a combustible wall and insulation between the wall and the boiler is not necessary, unless required by the local authority.

For electrical safety reasons there must be no access available from the back of the boiler.

The boiler must not be fitted outside.

Timber Framed Buildings

If the boiler is to be fitted in a timber framed building it should be fitted in accordance with the Institute of Gas Engineering document IGE/UP/7:2006 - Edition 2.

Bathroom Installations

This appliance is rated **IP20**.

The boiler may be installed in any room or internal space, although particular attention is drawn to the requirements of the current IEE (BS.7671) Wiring Regulations and the electrical provisions of the building regulations applicable in Scotland, with respect to the installation of the boiler in a room or internal space containing a bath or shower. For IE reference should be made to the current ETCI rules for electrical installations and I.S. 813:2002.

If the appliance is to be installed in a room containing a bath or shower then, providing water jets are not going to be used for cleaning purposes (as in communal baths/showers), the appliance must be installed beyond Zone 2, as detailed in BS.7671.

Compartment Installations

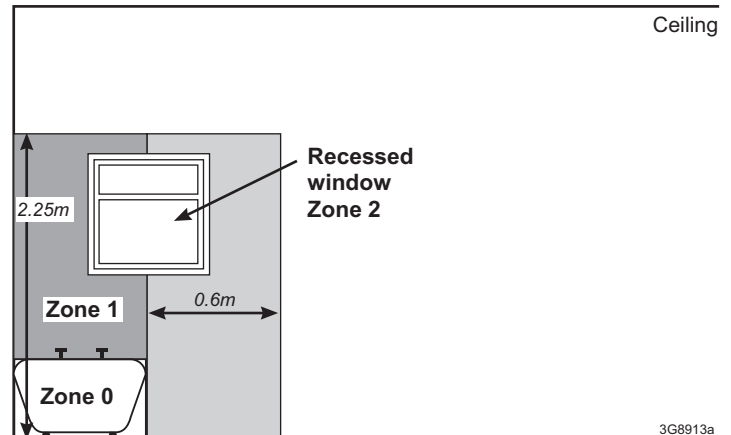

A compartment used to enclose the boiler should be designed and constructed specially for this purpose.

An existing cupboard or compartment may be used, provided that it is modified for the purpose.

In both cases, details of essential features of cupboard / compartment design, including airing cupboard installation, are to conform to the following:

- BS 6798 (No cupboard ventilation is required - see 'Air Supply' for details).
- The position selected for installation MUST allow adequate space for servicing in front of the boiler.
- For the minimum clearances required for safety and subsequent service, see the wall mounting template and Frame 1. In addition, sufficient space may be required to allow lifting access to the wall mounting plate.

GENERAL

GAS SUPPLY

The local gas supplier should be consulted, at the installation planning stage, in order to establish the availability of an adequate supply of gas. An existing service pipe must NOT be used without prior consultation with the local gas supplier.

The boiler MUST be installed on a gas supply with a governed meter only.

A gas meter can only be connected by the local gas supplier or by a Gas Safe Registered Engineer. In IE by a Registered Gas Installer (RGI).

An existing meter should be checked, preferably by the gas supplier, to ensure that the meter is adequate to deal with the rate of gas supply required.

It is the responsibility of the Gas Installer to size the gas installation pipework in accordance with BS6891:2005. Whilst the principle of the 1:1 gas valve ensures the Logic range is able to deliver it's full output at inlet pressures as low as 14mb, other gas appliances in the property may not be as tolerant. When operating pressures are found to be below the minimum meter outlet of 19mb these should be checked to ensure this is adequate for correct and safe operation.

Allowing for the acceptable pressure loss of 1mb across the installation pipework, it can be assumed that a minimum permitted operating pressure of 18mb will be delivered to the inlet of the appliance. (Reference BS 6400-1 Clause 6.2 Pressure Absorption).

The external gas cock could further reduce the operating pressure when measured at its test point. The pressure drop is relative to the heat input to the boiler (kW), refer to graph below.

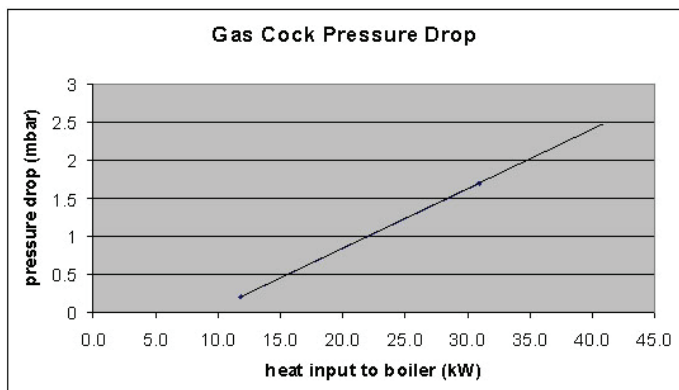

IMPORTANT.

Installation pipes must be fitted in accordance with BS.6891. In IE refer to IS.813:2002.

The complete installation MUST be tested for gas tightness and purged as described in the above code.

FLUE INSTALLATION

Plumbing will occur at the terminal so terminal positions where this could cause a nuisance should be avoided.

The flue must be installed in accordance with the recommendations of BS. 5440-1: 2008.

In IE refer to I.S. 813:2002.

The following notes are intended for general guidance:

1. The boiler MUST be installed so that the terminal is exposed to external air.
2. It is important that the position of the terminal allows the free passage of air across it at all times.
3. Minimum acceptable spacing from the terminal to obstructions and ventilation openings are specified in Table 4.

4. Where the lowest part of the terminal is fitted less than 2m (6'6") above a balcony, above ground or above a flat roof to which people have access then the terminal MUST be protected by a purpose designed guard.

Terminal guards are available from boiler suppliers. (Ask for TFC flue guard model no. K6 - round, plastic coated). In case of difficulty contact:

TFC Group Ltd. Tel. + 44 (0) 01732 351 680
 Tower House, Vale Rise Fax. + 44 (0) 01732 354 445
 Tonbridge. Kent TN9 1TB www.tfc-group.co.uk

Ensure that the guard is fitted centrally.

5. The flue assembly shall be so placed or shielded as to prevent ignition or damage to any part of any building.
6. The air inlet/products outlet duct and the terminal of the boiler MUST NOT be closer than 25mm (1") to combustible material. Detailed recommendations on the protection of combustible material are given in BS. 5440-1:2008.

IMPORTANT. It is essential to ensure, in practice, that products of combustion discharging from the terminal cannot re-enter the building or buildings through any openings into the building such as ventilators, windows, doors, or other sources of natural air infiltration, such as forced ventilation openings etc.

If products of combustion re-entry is identified or suspected this should be immediately investigated and corrected following the guidance provided in the current Gas Industry Unsafe Situation Procedure.

Table 4 - Balanced Flue Terminal Position

Flue Terminal Positions	Min. Spacing*
1. Directly below, above or alongside an opening window, air vent or other ventilation opening.	300mm (12")
2. Below guttering, drain pipes or soil pipes. <i>BS5440-1 2008</i>	25mm (1")* 75mm (3")
3. Below eaves. <i>BS5440-1 2008</i>	25mm (1")* 200mm (8")
4. Below balconies or a car port roof. <i>BS5440-1 2008</i>	25mm (1")* 200mm (8")
5. From vertical drain pipes or soil pipes. <i>BS5440-1 2008</i>	25mm (1")* 150mm (6")
6. From an internal or external corner or to a boundary along side the terminal. <i>BS5440-1 2008</i>	25mm (1")* 300mm (12")
7. Above adjacent ground, roof or balcony level.	300mm (12")
8. From a surface or a boundary facing the terminal.	600mm (24")
9. From a terminal facing a terminal.	1,200mm (48")
10. From an opening in a car port (e.g. door or window) into dwelling.	1,200mm (48")
11. Vertically from a terminal on the same wall.	1,500mm (60")
12. Horizontally from a terminal on the wall.	300mm (12")
Vertical Terminals	
13. Above the roof pitch with roof slope of all angles. Above flat roof.	300mm (12") 300mm (12")
14. From a single wall face. From corner walls.	300mm (12") 300mm (12")
15. Below velux window	2000mm (79")
16. Above or side of velux window	600mm (24")

* Only one reduction down to 25mm is allowable per installation otherwise BS5440-1 2008 dimensions must be followed.

GENERAL

TERMINAL

The terminal assembly can be adapted to accommodate various wall thicknesses. Refer to Frame 1.

AIR SUPPLY

It is NOT necessary to have a purpose-provided air vent in the room or internal space in which the boiler is installed. Neither is it necessary to ventilate a cupboard or compartment in which the boiler is installed, due to the low surface temperatures of the boiler casing during operation; therefore the requirements of BS 6798, Clause 12, and BS 5440:2 may be disregarded.

WATER CIRCULATION SYSTEM

IMPORTANT.

A minimum length of 1 metre of copper pipe MUST be fitted to both flow and return connections from the boiler before connection to any plastic piping.

The central heating system should be in accordance with BS.6798 and, in addition, for smallbore and microbore systems, BS.5449.

WATER TREATMENT - see Frame 4

BOILER CONTROL INTERLOCKS

Central heating systems controls should be installed to ensure the boiler is switched off when there is no demand for heating, in compliance with Building Regulations.

Heating systems utilising full thermostatic radiator valve control of temperature in individual rooms should also be fitted with a room thermostat controlling the temperature in a space served by radiators not fitted with such a valve.

When thermostatic radiator valves are used, the space heating temperature control over a living / dining area or hallway having a heating requirement of at least 10% of the minimum boiler heat output should be achieved using a room thermostat, whilst other rooms are individually controlled by thermostatic radiator valves. However, if the system employs thermostatic radiator valves on all radiators, or two port valves, then a bypass circuit must be fitted with an automatic bypass valve to ensure a flow of water should all valves be in the closed position.

ELECTRICAL SUPPLY

WARNING.

This appliance must be earthed.

Wiring external to the appliance MUST be in accordance with the current I.E.E. (BS.7671) Wiring Regulations and any local regulations which apply. For IE reference should be made to the current ETCI rules for electrical installations.

The mains supply to the boiler and system wiring centre shall be through one common fused double pole isolator. For new heating systems, and where practicable replacement boiler installations, the isolator shall be situated adjacent to the appliance.

CONDENSATE DRAIN

Refer to Frames 21, 22 & 38

A condensate drain is provided on the boiler. This drain must be connected to a drainage point on site. All pipework and fittings in the condensate drainage system MUST be made of plastic - *no other materials may be used.*

IMPORTANT.

Any external runs must be in accordance with BS 6798.

The drain outlet on the boiler is sized for standard 21.5mm (3/4") overflow pipe. It is a universal fitting to allow use of different brands of pipework.

GENERAL

1 BOILER DIMENSIONS, SERVICES & CLEARANCES

all dimensions in mm

The boiler connections are made on the boiler connection tails. Refer to Frame 23.

The following minimum clearances must be maintained for operation and servicing.

Additional space will be required for installation, depending upon site conditions.

Side and Rear Flue

a. Provided that the flue hole is cut accurately, e.g. with a core drill, the flue can be installed from inside the building where

wall thicknesses do not exceed 600mm (24"). Where the space into which the boiler is going to be installed is less than the length of flue required the flue must be fitted from the outside.

Installation from inside ONLY

b. If a core boring tool is to be used inside the building the space in which the boiler is to be installed must be at least wide enough to accommodate the tool.

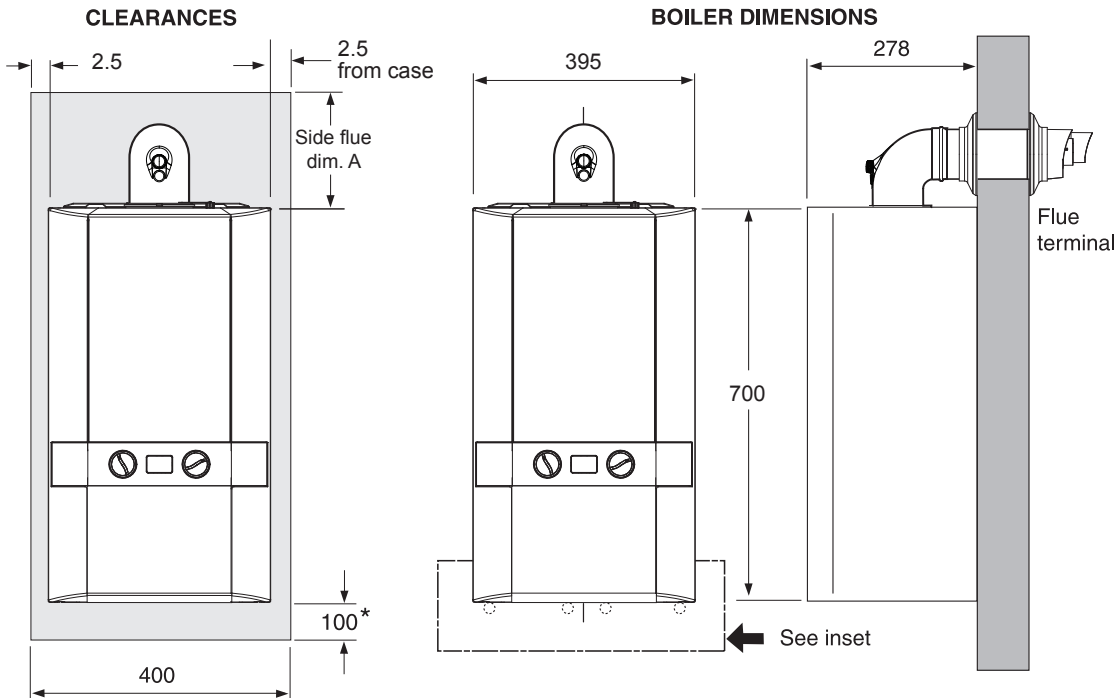

Inset: Water Connections and Gas Connection

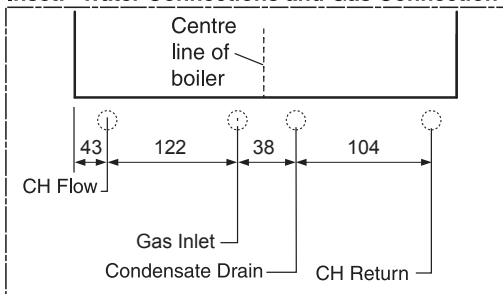

Front clearance

The minimum front clearance when built in to a cupboard is 5mm from the cupboard front door but 450mm overall clearance is still required, with the cupboard door open, to allow for servicing.

* Bottom clearance

Bottom clearance after installation can be reduced to 5mm.

This must be obtained with an easily removable panel, to enable the consumer to view the system pressure gauge, and to provide the 100mm clearance required for servicing.

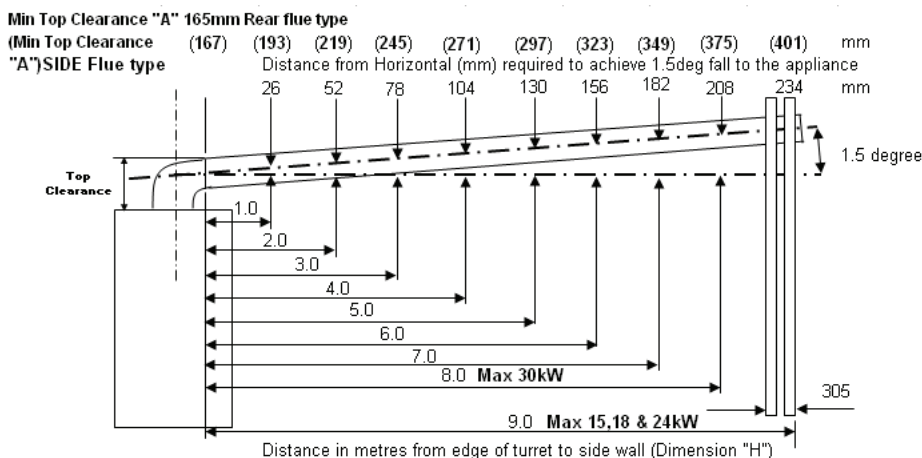

1. Dimension "H" must remain inside the Maximum flue length requirement for the designated kW capacity of the appliance been installed.
 2. For flue lengths requiring "D" pack extensions the flue must incline by 26mm per 1 Metre of flue length.
- No flue length greater that the maximum flue length shown above should be exceeded.

GENERAL

2 SYSTEM REQUIREMENTS - Central Heating

Notes

- a. The method of filling, refilling, topping up or flushing sealed primary hot water circuits from the mains via a temporary hose connection is only allowed if acceptable to the local water authority.
- b. Antifreeze fluid, corrosion and scale inhibitor fluids suitable for use with boilers having aluminium heat exchangers may be used in the central heating system.

General

1. The installation must comply with all relevant national and local regulations.
2. The installation should be designed to work with flow temperatures of up to 86 °C.
3. All components of the system must be suitable for a working pressure of 3 bar and temperature of 110 °C. Extra care should be taken in making all connections so that the risk of leakage is minimised.

The following components are incorporated within the appliance:

- a. Circulating pump.
 - b. Safety valve, with a non-adjustable preset lift pressure of 3 bar.
 - c. Pressure gauge, covering a range of 0 to 4 bar.
 - d. An 8-litre expansion vessel, with an initial charge pressure of 0.75 bar.
4. **'Make-up' Water.** Provision must be made for replacing water loss from the system, either :
 - a. From a manually filled 'make-up' vessel with a readily visible water level. The vessel should be mounted at least 150mm above the highest point of the system and be connected through a non-return valve to the system, fitted at least 150mm below the 'make-up' vessel on the return side of the radiators. **or**
 - b. Where access to a 'make-up' vessel would be difficult, by pre-pressurisation of the system.

The maximum cold water capacity of the system should not exceed 143 litres. This is the maximum system volume for the boiler expansion vessel. If the capacity of the vessel is not considered sufficient for this, or for any other reason, an additional vessel **MUST** be installed on the return to the boiler.

Guidance on vessel sizing is given in table opposite.

5. Filling

The system may be filled by the following method:

Through a temporary hose connection from a 'draw-off' tap, supplied from a service pipe under mains pressure. Where the mains pressure is excessive, a pressure reducing valve must be used to facilitate filling. When installing the filling device, it must be connected as below to fully comply with the water regulations.

This may involve the fitting of an additional WRAS approved isolator valve to the mains supply.

- i. Thoroughly flush out the whole system with cold water.
- ii. This boiler is designed to work with a low pressure supply. If sufficient mains pressure is available proceed as follows.
- iii. Fill and vent the system until the pressure gauge registers 1.5 bar, and examine for leaks.
- iv. Check the operation of the safety valve by raising the water pressure until the valve lifts. This should occur within 0.3 bar of the preset lift pressure.
- v. Release water from the system until the minimum system design pressure is reached; 1.0 bar if the system is to be pre-pressurised.

Note. Where supply pressures are less than 0.15bar the boiler / system fill point should be within 450mm of the boiler return isolation valve to ensure adequate filling of the boiler pump.

Safety valve setting	bar	3.0	
Vessel charge pressure	bar	0.5 to 0.75	
System pre-charge pressure	bar	None	1.0
System volume (litres)		Expansion vessel volume (litres)	
25		1.6	1.8
50		3.1	3.7
75		4.7	5.5
100		6.3	7.4
125		7.8	9.2
150		9.4	11.0
175		10.9	12.9
190		11.9	14.0
200		12.5	14.7
250		15.6	18.4
300		18.8	22.1
For other system volumes multiply by the factor across		0.063	0.074

Model	15IE	18IE	24IE	30IE
Max CH output kW (Btu/h)	15 (51,300)	18 (61,600)	24.2 (82,600)	30.3 (103,300)
Water flow rate l/min (gal/min)	10.7 (2.4)	13 (2.8)	17.2 (3.8)	21.5 (4.7)
Temp differential °C (°F)	20 (36)	20 (36)	20 (36)	20 (36)
Head available m.w.g. for system (ft.w.g.)	5 (16.2)	4.5 (14.7)	3.3 (10.8)	1.9 (6.2)

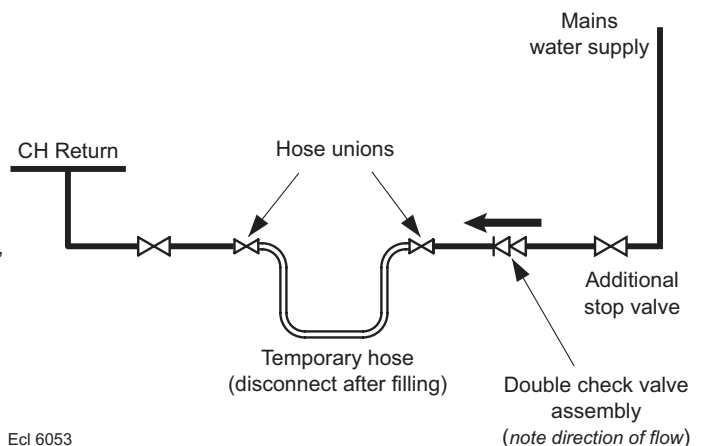

GENERAL

3 SYSTEM BALANCING

The boiler does not normally need a bypass but at least some radiators on the heating circuit, of load of at least 10% of the minimum boiler output, must be provided with twin lockshield valves so that this minimum heating load is always available. See note regarding thermostatic radiator valves on page 9.

Note. *Systems incorporating zone valves which could completely cut off the flow through the system must also include a bypass.*

BALANCING

1. Set the programmer to ON.

Close the manual or thermostatic valves on all radiators, leaving the twin lockshield valves (on the radiators referred to above) in the OPEN position.

Turn up the room thermostat and adjust the lockshield valve to give an uninterrupted flow through the radiator.

These valves should now be left as set.

2. Open all manual or thermostatic radiator valves and adjust the lockshield valves on the remaining radiators, to give

around 20°C temperature drop at each radiator.

3. Adjust the room thermostat and programmer to NORMAL settings.

4 WATER TREATMENT

CENTRAL HEATING

The Logic System IE range of boilers have an ALUMINIUM alloy heat exchanger.

IMPORTANT.

The application of any other treatment to this product may render the guarantee of Ideal Stelrad Group Invalid.

Ideal Stelrad Group recommend Water Treatment in accordance with the Benchmark Guidance Notes on Water Treatment in Central Heating Systems.

If water treatment is used **Ideal Stelrad Group** recommend only the use of SCALEMASTER GOLD 100, FERNOX, MBI, ADEY MC1 or SENTINEL X100 inhibitors and associated water treatment products, which must be used in accordance with the manufacturers' instructions.

Notes.

1. *It is most important that the correct concentration of the water treatment products is maintained in accordance with the manufacturers' instructions.*
2. *If the boiler is installed in an existing system any unsuitable additives MUST be removed by thorough cleansing. BS 7593:2006 details the steps necessary to clean a domestic heating system.*
3. *In hard water areas, treatment to prevent lime scale may be necessary - however the use of artificially softened water is NOT permitted.*
4. *Under no circumstances should the boiler be fired before the system has been thoroughly flushed.*

For further information contact:

Fernox Cookson Electronics
Forsyth Road
Sheerwater
Woking
Surrey GU21 5RZ
+44 (0) 870 601 5000

Sentinel Performance Solutions
The Heath Business & Technical Park
Runcorn
Cheshire WA7 4QX
Tel: 0800 389 4670
www.sentinel-solutions.net

Scalemaster Water Treatment Products
Emerald Way
Stone
Staffordshire ST15 0SR
Tel: +44 (0) 1785 811636

Calmag Ltd.
Unit 3-6, Crown Works
Bradford Road
Sandbeds, Keighley
West Yorkshire BD20 5LN
Tel: +44 (0) 1535 210 320

Adey Professional Heating Solutions
Gloucester Road
Cheltenham GL51 8NR
Tel: +44 (0) 1242 546700

INSTALLATION

5 BOILER ASSEMBLY - Exploded View

Note that item numbers are linked to the spares list

- | | | | | | |
|------|-------------------------|-----|-------------------------------------|-----|-----------------------------|
| 104 | CH RETURN VALVE | 205 | GAS VALVE | 304 | CONTROL THERMISTOR (RETURN) |
| 105 | CH FLOW VALVE | 206 | PIPE - GAS INJECTOR | 306 | ELECTRODE IGNITION |
| 108 | PUMP HEAD | 211 | INJECTOR ASSEMBLY | 307 | ELECTRODE DETECTION |
| 110 | PUMP AUTO AIR VENT | 214 | VENTURI | 308 | IGNITER UNIT |
| 113 | PRESSURE RELIEF VALVE | 215 | FAN | 309 | THERMISTOR CONTROL/NO FLOW |
| 114 | PIPE - PRV OUTLET | 217 | BURNER | 313 | IGNITION LEAD |
| 115A | UPPER FLOW PIPE | 218 | GASKET - BURNER | 314 | CONTROL BOX LENS |
| 115B | LOWER FLOW PIPE | 219 | SUMP CLEAN OUT COVER | 324 | CONTROLS BOX LID |
| 116 | PIPE - RETURN | 223 | FLUE MANIFOLD | 325 | CONTROL BOX FRONT |
| 117 | PIPE - EXPANSION VESSEL | 224 | FLUE MANIFOLD TOP | 401 | HEAT ENGINE |
| 118 | EXPANSION VESSEL | 227 | CLAMP RETAINING FLUE TURRET | 503 | WALL MOUNTING BRACKET |
| 120 | FLOW GROUP MANIFOLD | 228 | HOSE CONDENSATE INTERNAL | 504 | FRONT PANEL |
| 121 | BY-PASS KIT | 229 | SIPHON TRAP | 505 | FASCIA |
| 135 | PRESSURE GAUGE | 231 | CONDENSATE OUTLET CONNECTION | 506 | BRACKET - GAS VALVE |
| 139 | FLOW SENSOR | 301 | CONTROLS BOX FIXINGS HINGE & SPRING | 507 | BRACKET - EXPANSION VESSEL |
| 203 | GAS COCK | 302 | PRIMARY PCB* | | |
| 204 | PIPE - GAS INLET | 303 | CUI BOARD | | |

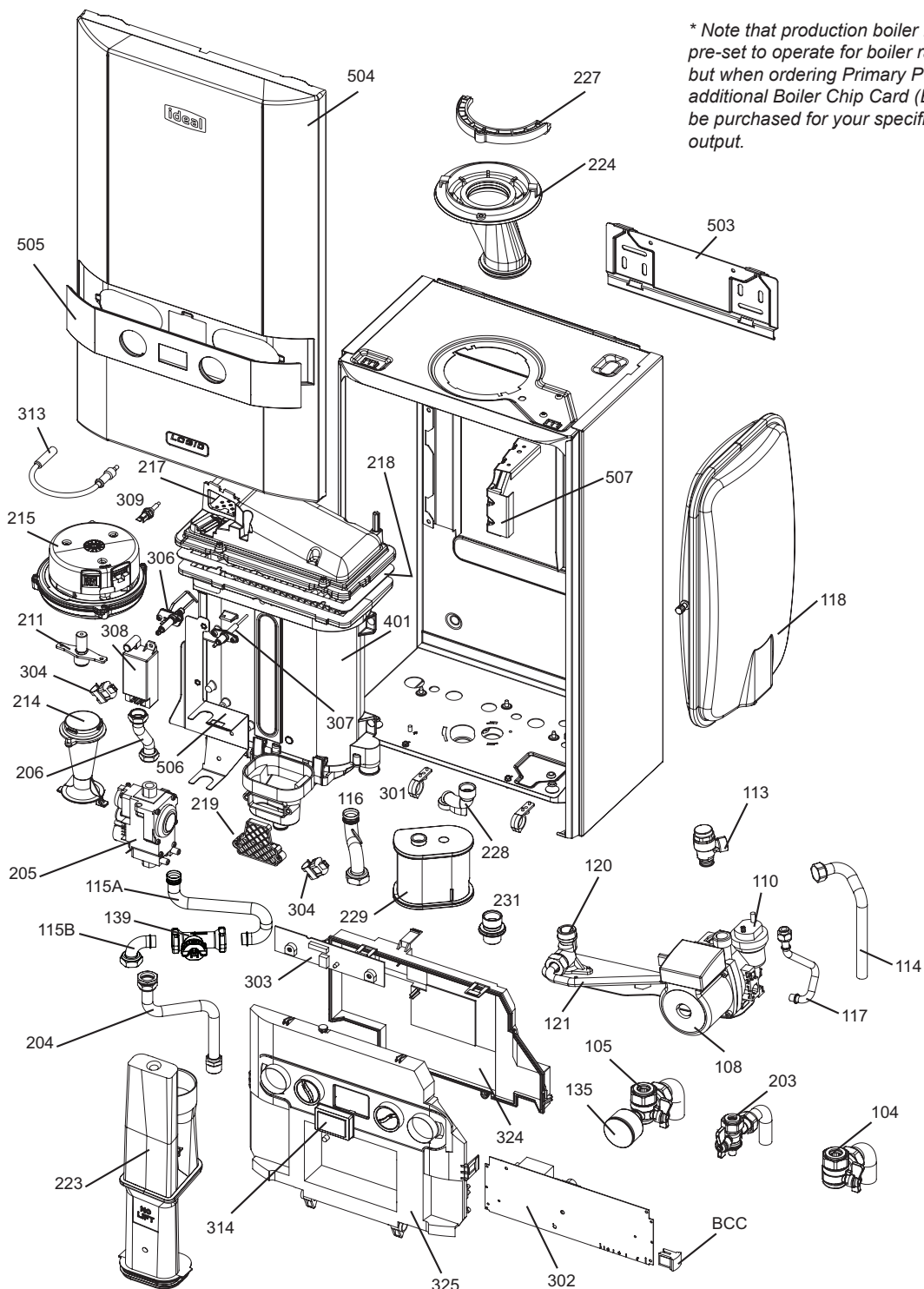

* Note that production boiler PCBs are factory pre-set to operate for boiler range and output, but when ordering Primary PCB as a spare, an additional Boiler Chip Card (BCC) MUST also be purchased for your specific boiler range and output.

INSTALLATION

INSTALLATION

6 UNPACKING

The boiler is supplied fully assembled in Pack A. A telescopic or non-telescopic flue assembly for rear or side flue outlet in Pack B is supplied as a separate order.

Unpack and check the contents.

Pack A Contents

- A Boiler
- B Hardware Pack Box
- C Wall Mounting Plate
- D These Installation/Users Instructions
- E Wall Mounting Template (located on internal protective packaging)
- F Turret Clamp
- G Boiler Guarantee & Registration Pack

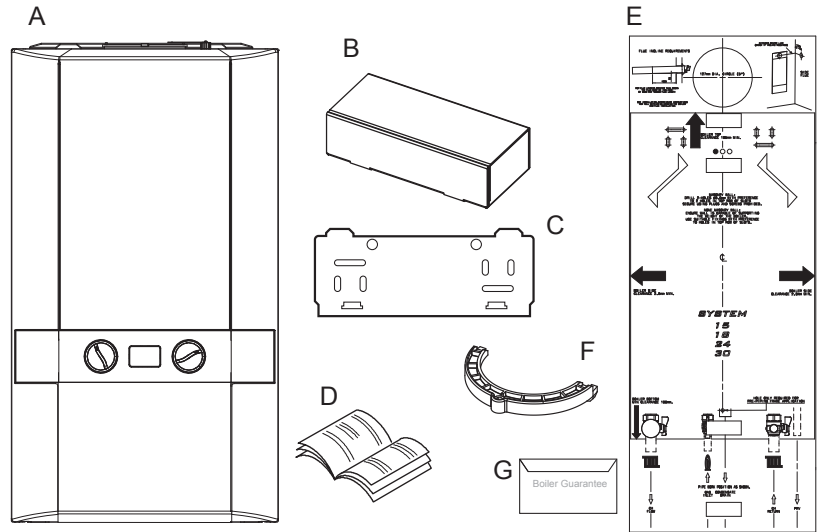

HARDWARE PACK CONTENTS

Gas Valve Pack

1. Pipe - Gas Inlet
2. Washer - Gas (blue)
3. Gas Cock

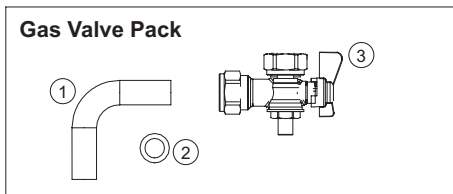

Return Valve Pack

1. Pipe CH Return
2. Washer CH
3. Valve Return

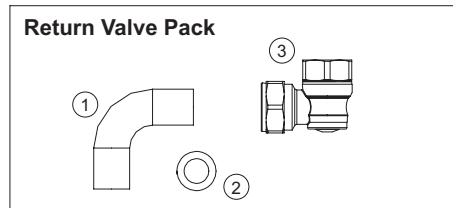

Accessory Pack

1. Screw (x2)
2. Wallplug (x2)
3. Turret Clamp Screw (x1)

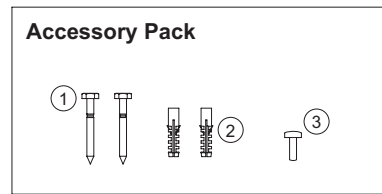

Flow Valve Pack

1. Pipe CH Flow
2. Washer CH
3. Valve Flow (with gauge)

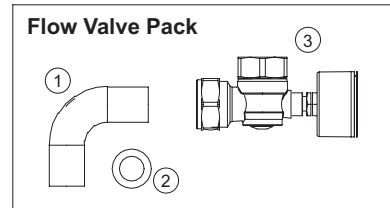

7 UNPACKING....CONT'D

Note. This flue system incorporates a removable flue outlet nose that utilises a push fit location system. This enables the installation of deflector, high level or balcony outlet flue kits without the removal of the whole 'B' pack terminal. The appliance must not be operated without the desired outlet nose correctly fitted in place.

Note. Location dimples must be aligned with terminal mounting frame.

Pack B Contents Non-Telescopic

- A Flue terminal
- B Flue turret
- C Rubber terminal wall seal
- D Cutting Aid
- E Wall Seal (white)

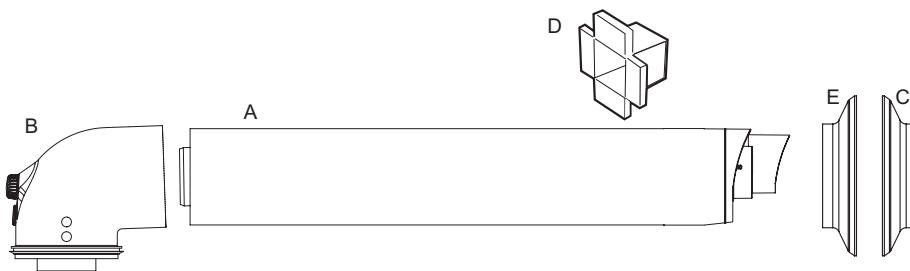

Pack B Contents Telescopic

- A Telescopic flue terminal
- B Flue turret
- C Rubber terminal wall seal
- D Screw
- E Sealing Tape
- F Wall Seal (white)

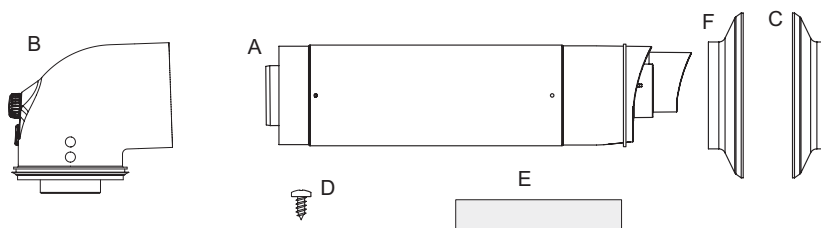

8 FRONT PANEL REMOVAL

1. Loosen the 2 screws retaining the front panel.
2. Pull the two spring clips downwards to disengage.
3. Pull the front panel forward and upwards to remove.

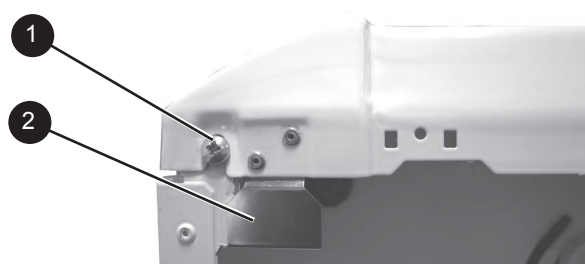

INSTALLATION

9 WALL MOUNTING TEMPLATE

The wall mounting template is located on the internal protective packaging. The template shows the position of the fixing and rear flue centre holes for a standard installation

Care **MUST** be taken to ensure the correct holes are drilled.

1. Tape template into the required position, ensuring its squareness by hanging a plumbline as shown.
2. If fitting a side flue, extend the flue centreline onto the side by **155mm** on a standard wall fix or **200mm** if using a stand-off bracket.
3. Mark the following on to the wall:
 - a. The selected group of wall mounting screw holes.
 - b. The centre position of the flue duct. Marking both the centre and the circumference of the flue duct.
4. Remove the template plate from the wall.

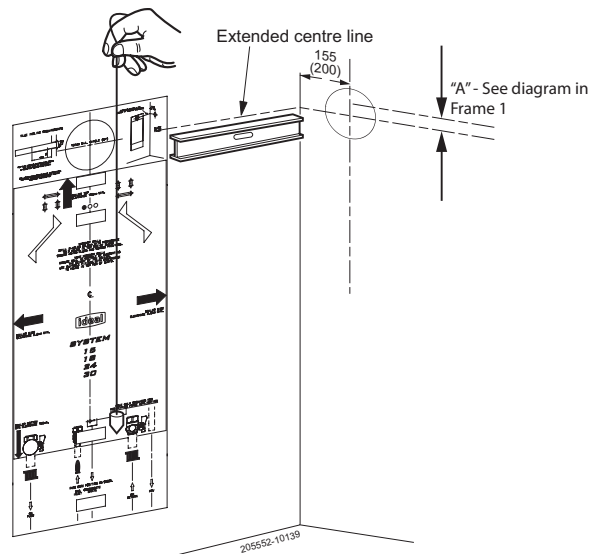

10 PREPARING THE WALL

IMPORTANT.

Ensure that, during the cutting operation, masonry falling outside of the building does not cause damage or personal injury.

1. Cut the flue hole (preferably with a 5" core boring tool), ensuring that the hole is square to the wall. Both wall faces immediately around the cut hole should be flat.
2. Drill 2 mounting holes (marked from template) with a 7.5mm / 8mm masonry drill and insert the plastic plugs, provided, for the wall mounting plate.
3. Locate 2 No.14 x 50mm screws in the wall mounting plate (one at each side, in any of the 3 holes provided at each side) and screw home. Ensure mounting bracket is level.

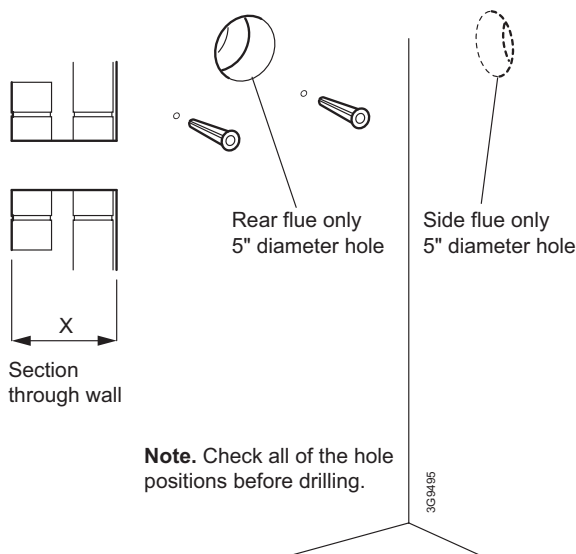

11 FITTING THE WALL MOUNTING PLATE

Screw the wall mounting plate to the wall using 2 wall plugs (previously fitted) with the 2 screws provided.

Choose one of the 2 sets of slots in left and right bank. Ensuring that at least one of the screws is fitted into a top slot.

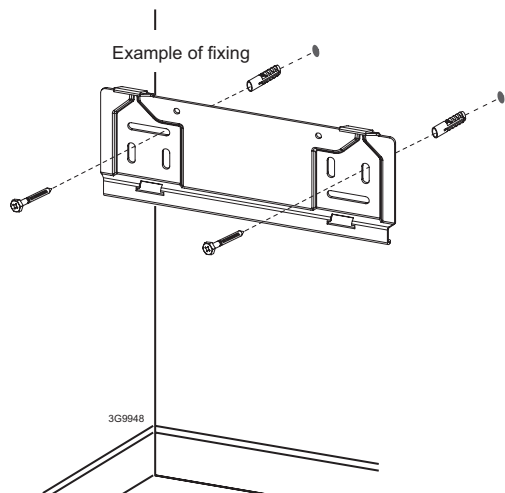

12 MOUNTING THE BOILER

1. Ensure the plastic plug is removed from the CH connections before mounting the boiler.
2. Lift the boiler onto the wall mounting plate (refer to the Introduction section for safe handling advice), locating it over the two tabs.

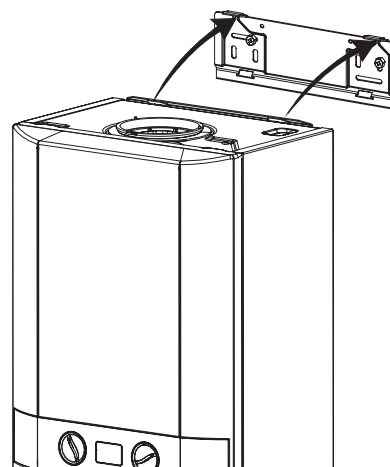

INSTALLATION

13 DETERMINING THE FLUE LENGTH AND FLUE PACKS REQUIRED

IMPORTANT. The boiler must be installed in a vertical position in accordance to the installation instructions.

FLUE KITS

Telescopic Flue 'B' Pack - contains: Flue turret, telescopic flue incorporating a terminal and rubber wall seals.

Horizontal Flue Terminal (600mm long) 'B' Pack - contains: Flue turret, non telescopic single piece flue incorporating a terminal and rubber wall seals.

Horizontal Flue Terminal (1000mm long) 'B' Pack - Flue turret, telescopic flue incorporating a terminal, rubber wall seals and instructions.

Note. If 'B' packs are used on their own (either 1 piece or telescopic), then they can be fitted horizontally as the flue inside is designed to slope 1.5 degrees.

'D' Pack - contains: 1 metre length of flue pipe (Functional length 950mm), 1 support bracket and instructions.

When extension 'D' Packs are used the flue duct must incline 1.5 degrees away from the appliance, to allow the condensate to drain back to the boiler and out of the condensate drain. It is recommended that a support bracket is fitted on every 1 metre of pipe work used and the bracket is located as close to the collar as possible. The bracketing must ensure a 1.5 degree fall back to the appliance.

Optional Flue Finishing Kit - UIN 155988 & Concentric Flue Screw Retaining Kit (Optional Kit of mechanical fixing of flue joints)

Only use water as a lubricant during assembly.

The 'B' pack terminal is classed as part of the maximum flue length.

These flue systems incorporates a removable flue outlet nose that utilises a push fit location system. This enables the installation of deflector, high level or balcony flue kits without the removal of the whole 'B' pack terminal. The appliance must not be operated without the desired outlet nose correctly fitted in place, ensuring the side location dimples are in line with the mounting face allowing the correct sealing of the components.

It is IMPORTANT that all attachments are fitted in accordance to the installation instructions provided with them.

The TURRET supplied in the 'B' Pack has an upper combustion sample point with a screw cap seal and a lower air sample point with an air stopper seal. Ensure all caps & seals are in place.

Additional Termination Kits available for use with these 'B' packs.

Flue Deflector Kit	The resistance is the equivalent of 1 metre of flue pipe and therefore must be deducted from any maximum flue length
High Level Flue Outlet Kit	The maximum permissible concentric flue length when using a standard (500mm) kit is 4.5 metres
Balcony Flue Outlet Kit	The maximum permissible concentric flue length when using this kit is dependant on the length of the balcony flue outlet run which combined with the concentric run must not exceed the maximum flue length requirement of the appliance it is to be fitted to

Total Maximum Permissible Horizontal Concentric Flue Length combining both 'B' Packs and 'D' Packs
(Measured from centreline of the turret to the outside of the wall terminal)

15, 18 & 24 kW appliances	Total Maximum: 9 metres - minus any flue kit options or bends
30 kW Appliances	Total Maximum: 8 metres - minus any flue kit options or bends

Total Maximum Permissible Vertical Flue Length combining both Roof Terminal and 'D' Packs

15, 18, 24 & 30kW Appliances	Total Maximum: 7.5 Metres - minus any bends
Powered Vertical Flue	
15, 18, 24 & 30kW Appliances	Total Maximum: 5 Metres - Concentric Flue and 17m flue pipe only. For additional details refer to the powered Vertical Instructions

90° Elbow Kit 60/100 - (Equivalent flue length resistance = **1M**)

45° Elbow Kit 60/100 - (Equivalent flue length resistance = **0.6M**)

Minimum Horizontal Flue Lengths (Centre line of turret to outside of wall terminal)

Telescopic Flue 'B' Pack = 400mm

Horizontal Flue terminal (600mm long) 'B' Pack = 285mm

Wall Thickness

Std Metric Brick 102.5mm wide

'B' Pack Flue Type 60/100	Minimum permissible Wall Thickness			Maximum permissible Wall Thickness		
	Rear Flue	Rear Flue + Std-Off	Side Flue	Rear Flue	Rear Flue + Std-Off	Side Flue
Horizontal Flue Terminal (600mm long) B Pack	116	102.5	102.5	501	456	456
Telescopic Flue B Pack	231	186	186	429	384	384
Horizontal Flue Terminal (1000mm long) B Pack	546	501	501	761	716	716
Horizontal Flue Terminal (1000mm long) B Pack cut 75mm	471	426	426	686	641	641

For Flue lengths between 658 & 708 use a Horizontal Flue Terminal (1000mm long) B Pack, cut 75mm off the end of the terminal section of the telescopic flue only.

INSTALLATION

14 DETERMINING THE FLUE LENGTH AND FLUE PACKS REQUIRED, CONT'D

FIGURE 1

Note. Maximum permissible flue length is measured from centre line of appliance flue outlet to outside wall face.

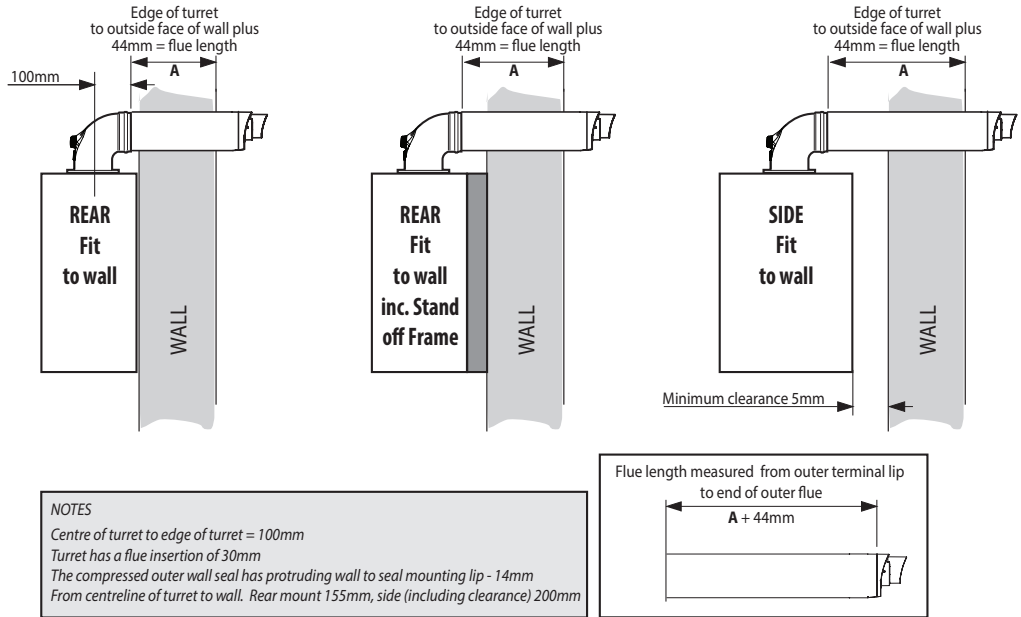

FIGURE 2

Shows the flue required when measured from outside edge of turret to the outside face of the wall (to obtain cut length add 44mm)

	Minimum & Maximum finished flue lengths obtainable (dimension 'A' +44mm)								
	Horizontal Flue Terminal (600mm long) B Pack		Telescopic Flue B Pack		Horizontal Flue Terminal (1000mm long) B Pack (Telescopic)		Horizontal Flue Terminal (1000mm long) B Pack (Telescopic) Cut 75mm		
	Minimum	Maximum	Minimum	Maximum	Minimum	Maximum	Minimum	Maximum	
B Pack (Standard)	171	556	286	484	601	816	526	741	Max output 30 kW Max output 15, 18 & 24 kW
Plus 1 (1m D pack)	1121	1506	1236	1434	1551	1766	1476	1691	
Plus 2 (1m D pack)	2071	2456	2186	2384	2501	2716	2426	2641	
Plus 3 (1m D pack)	3021	3406	3136	3334	3451	3666	3376	3591	
Plus 4 (1m D pack)	3971	4356	4086	4284	4401	4616	4326	4541	
Plus 5 (1m D pack)	4921	5306	5036	5234	5351	5566	5276	5491	
Plus 6 (1m D pack)	5871	6256	5986	6184	6301	6516	6226	6441	
Plus 7 (1m D pack)	6821	7206	6936	7134	7251	7466	7176	7391	
Plus 8 (1m D pack)	7771	8186	7886	8084	8201	8416	8126	8341	
Plus 9 (1m D pack)	8721	9000	8836	9000	9000	9000	9000	9000	

Note; Telescopic flue B Pack or attached "D" pack extensions do not need to be cut between minimum and maximum values shown above (except where specified). Horizontal Flue Terminal (600mm long) B Pack flue will require cutting on values below maximum values shown in the table above.

FLUE OUTLET

15 CUTTING & SETTING THE FLUE LENGTH

TELESCOPIC FLUES

TELESCOPIC FLUE B PACK SHOULD ONLY BE ADJUSTED FOR USE WITHIN ITS SPECIFIED RANGE AND MUST NOT BE CUT

HORIZONTAL FLUE TERMINAL (1000MM LONG) B PACK (TELESCOPIC) MUST ONLY BE CUT IF REQUIRED FLUE LENGTHS ARE BETWEEN **602 & 652MM**. THIS WILL REQUIRE 75MM TO BE CUT OFF THE TERMINAL END OF THE 1000MM TELESCOPIC FLUE.

ALL OTHER LENGTHS OBTAINED USING "D" PACK EXTENSIONS IN FLUE LENGTH TABLE 1, COLUMN "HORIZONTAL FLUE TERMINAL (1000MM LONG) B PACK CUT 75MM" (TELESCOPIC) SHOULD HAVE THE 75MM CUT OFF THE "D" PACK EXTENSION AND NOT TELESCOPIC FLUE

CUT 75MM OFF HORIZONTAL FLUE TERMINAL 1000MM LONG B PACK (TELESCOPIC)

1. Measure cut flue length (A+44mm). (If required telescopic length is not between 658 and 708 then proceed to "Setting Telescopic Flue B Pack").
2. Remove telescopic end piece from the flue body and set aside.
3. Mark the circumference 75mm from the open end of the outer flue.
4. Cut along the 75mm mark cutting **only the outer flue** ensuring the cut is square.
5. Dress the cut end to make sure all burr is removed and the cut edge is in its original shape.
6. Measure 20mm from the newly cut edge of the outer flue, place a mark at the top of the flue approximately 20mm wide & write stop the terminal side of the line.
7. Mark the inner tube 10mm longer than the outer tube around its circumference and cut following the mark to ensure its cut square
8. Remove all burrs and place a chamfer on the outer edge to aid assembly.
9. Re-assemble telescopic section.

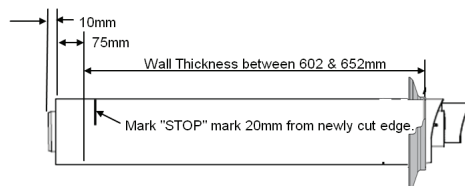

SETTING TELESCOPIC FLUE B PACK

1. Measure the required flue length (A+44mm).
2. Measure from the outer terminal lip to end of outer flue. Pull apart flue until desired length is achieved. ENSURE THE STOP MARK IS NOT VISIBLE, IF IT IS, THE FLUE IS TOO SHORT AND SHOULD NOT BE USED.
3. Check that both flue seams are at the top and the outlet terminal is upper most.
4. Drill a 3.5mm hole through one of the 2 outer side holes in the outer flue section into the inserted outer flue (as shown). Take care not to pierce the inner plastic flue. Fit screw provided.
5. Seal the joint on the outer air duct with the tape provided.
6. Fit internal and external wall seals (see installing flue)

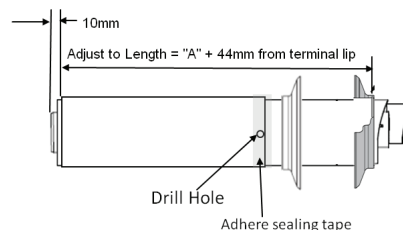

CUTTING HORIZONTAL FLUE TERMINAL (600MM LONG) B PACK

1. Measure the required cut flue length (A+44mm). If inside the dimensions shown in Figure 2 "1 Piece 600mm" proceed.
2. Measure from the outer terminal lip to end of outer flue. Mark the required cut length (A+44) around the circumference of the outer flue and cut following the mark to ensure its cut square.
3. Dress the cut end to make sure all burr's are removed and the cut edge is in its original shape.
4. Mark the inner tube 10mm longer than the outer tube around its circumference and cut following the mark to ensure its cut square.
5. Remove all burrs and place a light chamfer on the outer edge to aid assembly.

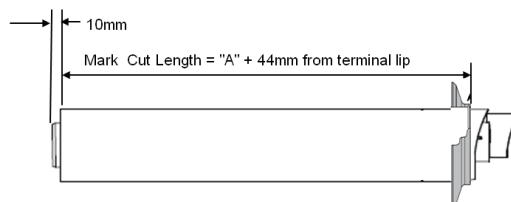

16 INSTALLING THE FLUE

FITTING FLUE THROUGH THE WALL

1. Measure wall thickness and add 14mm.
2. Measure from the outer terminal lip towards the end of outer flue, place a small location mark at the dimension acquired at point 1.
3. Add a further 14mm to the dimension, obtain at item 1 (point 1) and place an additional small location mark.
4. Fit external black wall seal ensuring the inside of the outer lip is in contact with the terminal lip you have been measuring from (see fig 1)
5. Fit the internal wall seal approximately 65mm before the outer of the 2 location marks.
6. For an internal fit place flue terminal in the centre of the 5" drilled hole in the wall. Apply pressure and lightly move the flue left to right or up and down. This will cause the outer flange to fold in and allow the flue to pass through the wall.
7. Push through a further 65mm or until the inner flange is press against the inner wall. This will allow the outer flange to return to its original shape.
8. Pull back the flue until the first of the 2 location marks is level with the internal face of the wall.

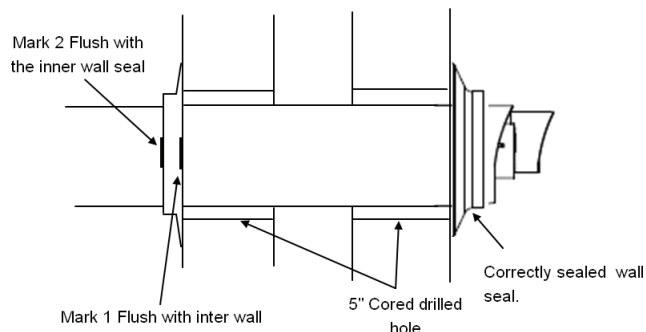
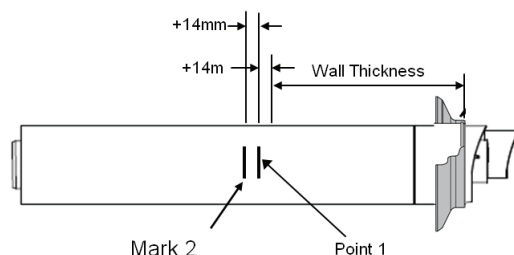

Note. If the 2 location marks are not visible then the flue is not pulled back far enough to obtain the correct seal. If the 1st location mark has passed the face of the wall the flue has been pulled to far back and the outer wall seal will have been dislodged from its mounting and will need to be refitted.

9. When 1st mark is in line with the wall, whilst holding the flue firmly, push the white wall sealing flange to the wall until the 2nd of the two marks is just visible. If the last location mark is clearly passed the white inner wall seal then the outer wall seal will have been dislodged from its mounting and will need to be re-fitted.
10. Ensure the seam and the outlet terminal are at the top and fitted as shown.

Note. If less than 50% of the length of the flue is internal the flue should be fitted from outside.

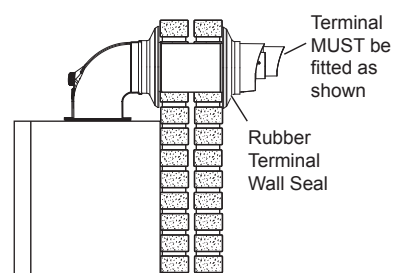
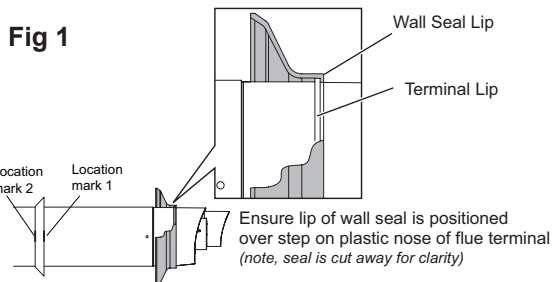

FITTING THE TURRET

1. Ensure the rubber seal is fitted correctly on the appliance manifold and that all flue seals are undamaged.
2. Hold the flue firmly and push the turret on until it has travelled 30mm on to the flue pipe and is fully engaged. Make sure the flue has not rotated or moved forward during fitting and the flue seam is upper most.
3. Push the turret into the manifold ensuring the upper plastic lip is flush with the top of the manifold.
4. Fully engage the clamp location section into the manifold location holes. Rotate down on to turret flange.
5. Secure clamp to appliance using securing screw.
6. Ensure all sample points are accessible and all sample plugs and caps are fitted.

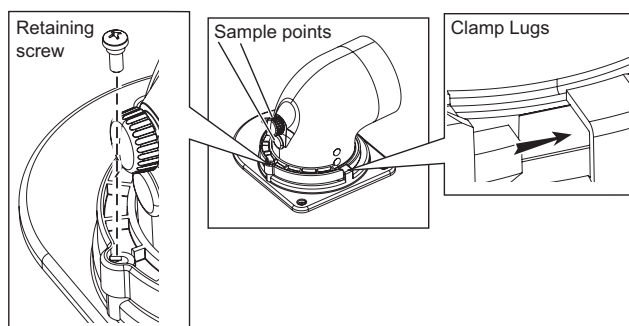
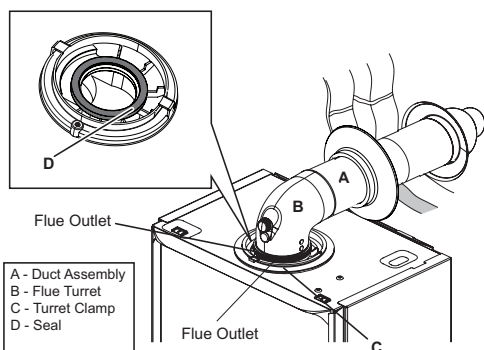

INSTALLATION

17 FITTING THE OPTIONAL ROOF FLUE KIT (Flat or Pitched)

Note.

A flat or pitched roof flashing plate (not supplied) is required before proceeding with the installation of this kit.

This kit is suitable for both flat and pitched roof terminations, using a concentric flue to run vertically from the top of the boiler and terminating above roof level.

Connection to the top of the boiler is made using a separately supplied vertical connector.

WEATHER PROOFING

Where the flue passes through the roof line an adequate seal must be made. This is achieved by using either:

- Flat roof weather collar
- or
- Universal weather collar.

ACCESSORIES

Flue Duct Extension Kits are available for flue lengths extending beyond 1m. These packs contain 1m extension ducts and may be cut to the desired length.

If the offset vertical option is used an elbow Kit is required. For a full accessories list refer to page 6, Optional Extras.

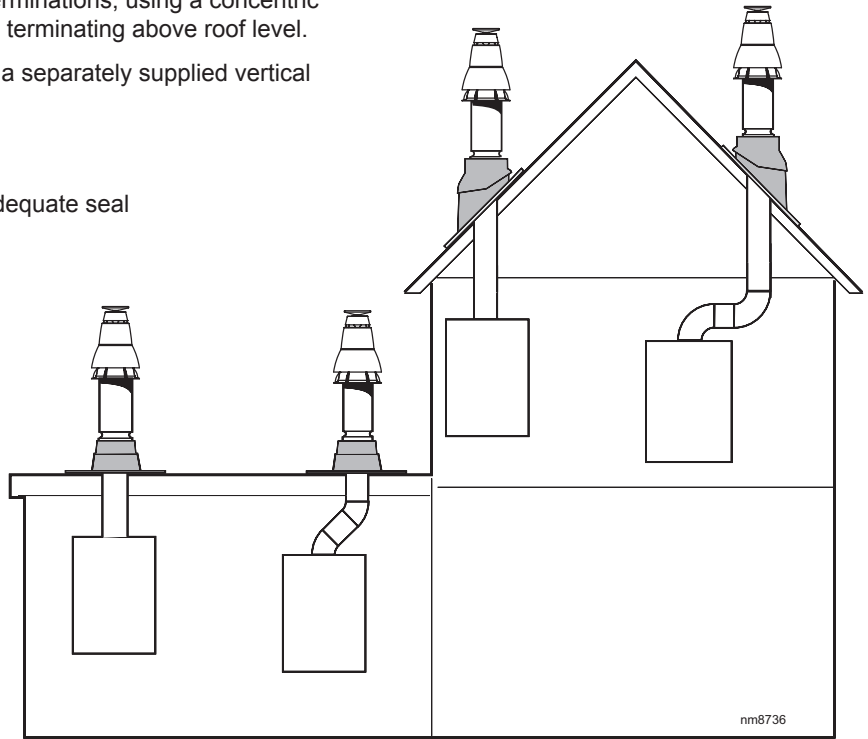

18 ROOF FLUE KIT CONTENTS / OPTIONS

Flue Terminal
UIN 203132

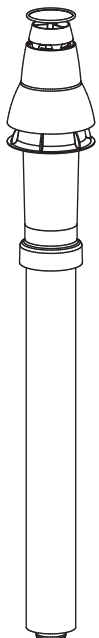

Flue Seal Collar - Flat Roof
UIN 152259

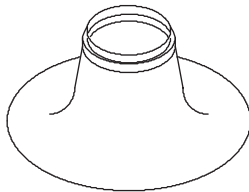

Vertical connector
UIN 208175



90° elbow
UIN 203130



Flue duct support



Flue Seal Collar - Tile Roof
UIN 152258

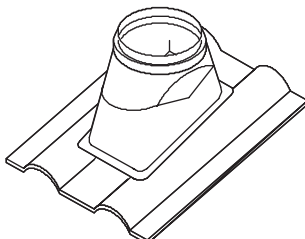

45° elbow
UIN 203131

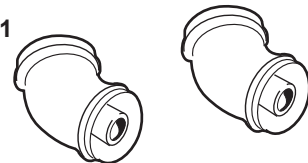

Roof Flue Extension Duct
UIN 203129

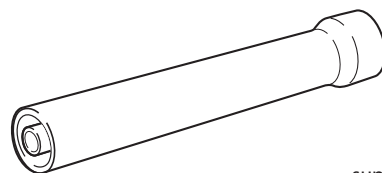

Flue duct support

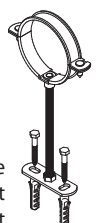

INSTALLATION

19 FLUE TERMINAL POSITION

The terminal should be positioned so that products of combustion can safely disperse at all times.

Plumbing may occur at the termination so, where possible, terminal positions where this could cause a nuisance should be avoided.

Minimum dimensions are shown below

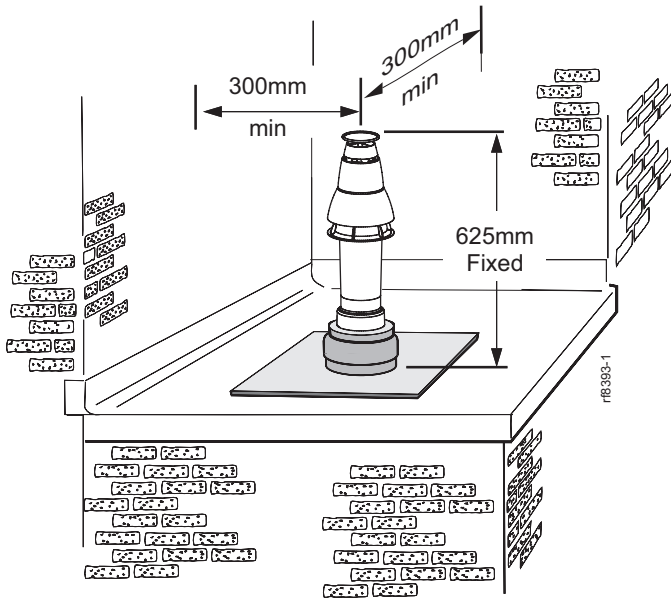
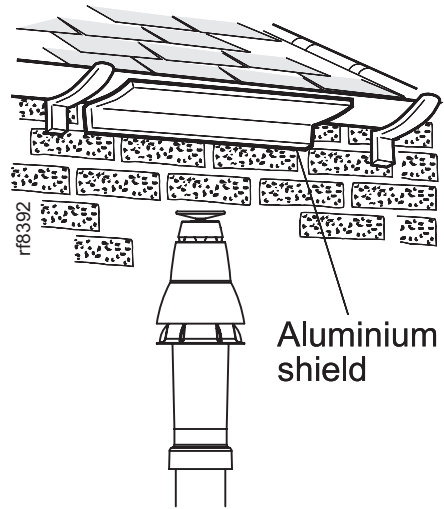

Flat roof - with structure

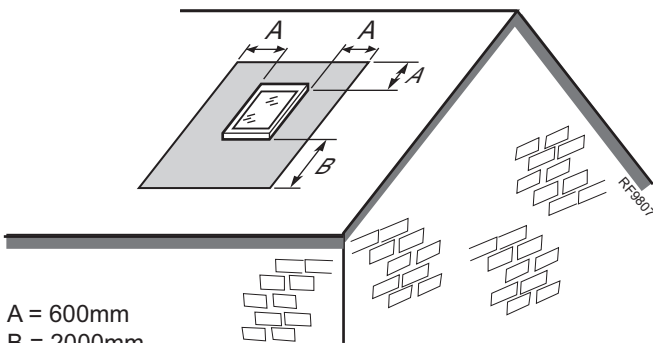
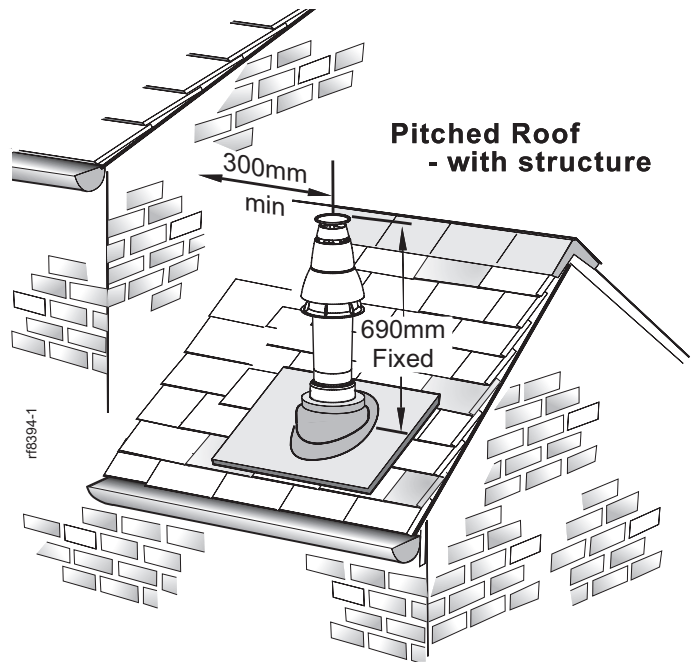

A = 600mm
B = 2000mm

The flue terminal shall not penetrate the shaded area of the roof

Terminal Position	Minimum Dimension
Directly below an opening, air brick, windows, etc.	300 mm
Below plastic / painted gutters	300 mm
Painted surface	300 mm
Below eaves or balcony	500 mm
Below velux windows	2000mm
Above or side of velux windows	600mm

Note.

The equivalent flue length resistance of the elbow kits are:

90° elbow kit = 1m

45° elbow kit = 0.6m

INSTALLATION

20 ASSEMBLING THE ROOF FLUE KIT

Determine the correct height that the flue should terminate above the roof. If after calculating or measuring the overall flue height from the top of the boiler, it is necessary to cut both pipes of assembly A, then ensure they are cut equally leaving the inner flue tube longer than the outer air tube as supplied.

Ensure the cut pipe ends are free from any burrs.

1. Position the roof flashing plate (supplied separately) over the hole cut in the roof and insert flue terminal from the roof end.

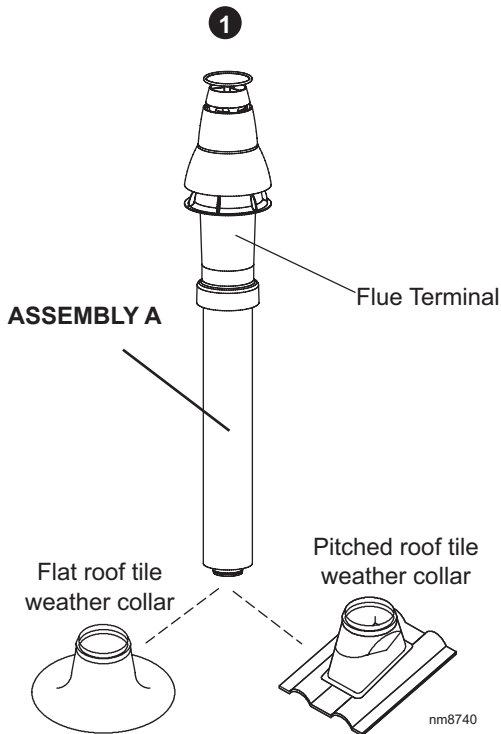
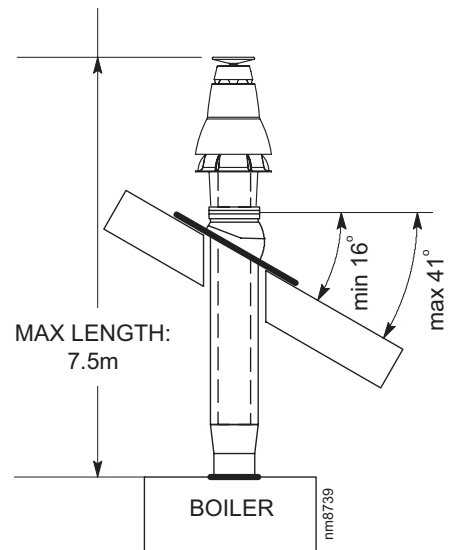

2. Fit the vertical connector (supplied separately) in accordance with the in the instructions provided with the vertical connector kit.
3. Secure the vertical connector by applying downward pressure on the connector.
4. Position the clamp on the top face of the flue manifold and push it horizontally backwards. Locate both clamp lugs into the flue manifold and secure to the flue manifold with the M5 retaining screw.
5. "Push" fit extension duct (if required (supplied separately)) into vertical connector.

Note. Ensure turret sample points are servicable and all caps and plugs are fitted.

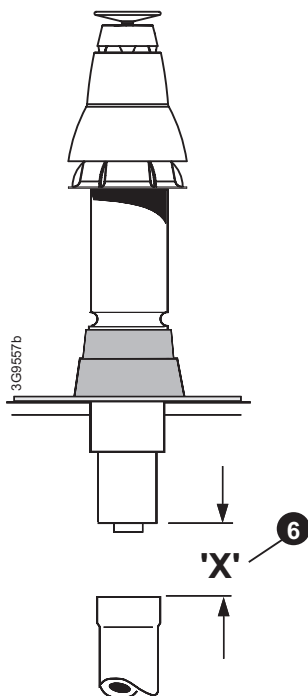

6. If the last extension duct requires cutting, measure 'X', the distance (outer ducts), between the duct and the terminal and add 100 mm to this dimension. This gives the length of the last extension duct.

Note. Check the position of the inner flue duct relative to the outer duct on the assembled extension duct(s) and ensure the terminal flue duct is cut longer than the air duct to ensure engagement in the final flue duct seal.

7. Finally ensure the roof flashing plate is correctly sealed to the roof.

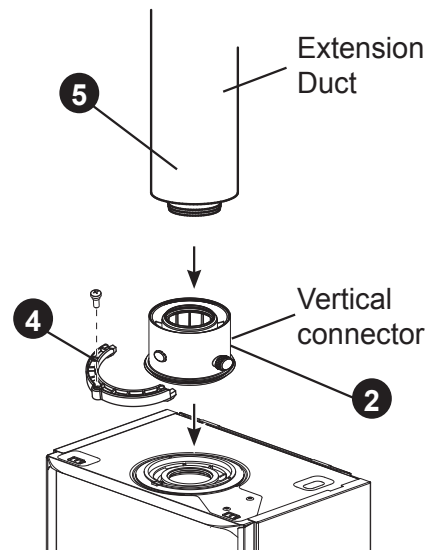

21 CONDENSATE DRAIN

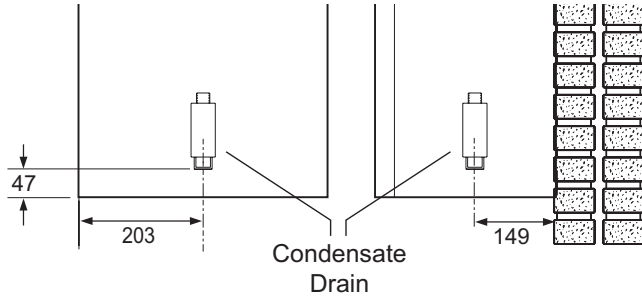

This appliance is fitted with a siphonic 75mm condensate trap system that requires filling before operating the appliance for the 1st time or after maintenance.

All condensate pipework should conform to the following:

- a. Where a new or replacement boiler is being installed, access to an internal 'gravity discharge' termination should be one of the main factors considered in determining boiler location.
- b. Plastic with push fit or solvent connections.
- c. Internal plastic pipe work a minimum of 19mm ID (typically 22mm OD)
- d. External plastic pipe must be a minimum of 30mm ID (typically 32 OD) before it passes through the sleeved wall.
- e. All horizontal pipe runs, must fall a minimum of 45mm per metre away from the Boiler.
- f. External & unheated pipe work should be kept to a minimum and insulated with Class "O" waterproof pipe insulation.
- g. All installations must be carried out in accordance to the relevant connection methods as shown in the "Condensate installation diagrams" & BS6798:2009
- h. Pipe work must be installed so that it does not allow spillage into the dwelling in the event of a blockage (through freezing)
- i. All internal burrs should be removed from the pipe work and any fittings.

In order to minimise the risk of freezing during prolonged very cold spells, one of the following methods of terminating condensate drainage pipe should be adopted.

Internal Drain Connections

Wherever possible, the condensate drainage pipe should be routed to drain by gravity to a suitable internal foul water discharge point such as an internal soil and vent stack or kitchen or bathroom waste pipe etc. See Figs 1 and 2.

Condensate Pump

Where gravity discharge to an internal termination is not physically possible or where very long internal pipe runs would be required to reach a suitable discharge point, a condensate pump of a specification recommended by the boiler or pump manufacturer should be used terminating into a suitable internal foul water discharge point such as an internal soil and vent stack or internal kitchen or bathroom waste pipe etc. (fig 3).

External Drain Connections

The use of an externally run condensate drainage pipe should only be considered after exhausting all internal termination options as described previously. An external system must terminate at a suitable foul water discharge point or purpose designed soak away. If an external system is chosen then the following measures must be adopted:

The external pipe run should be kept to a minimum using the most direct and "most vertical" route possible to the discharge point, with no horizontal sections in which condensate might collect.

- For connections to an external soil/vent stack see Fig 4. Insulation measures as described should be used.
- When a rainwater downpipe is used, an air break must be installed between the condensate drainage pipe and the downpipe to avoid reverse flow of rainwater into the boiler should the downpipe become flooded or frozen, see Fig 5.
- Where the condensate drain pipe terminates over an open foul drain or gully, the pipe should terminate below the grating level, but above water level, to minimise "wind chill" at the open end. The use of a drain cover (as used to prevent blockage by leaves) may offer further prevention from wind chill. See Fig 6.
- Where the condensate drain pipe terminates in a purpose designed soak away (see BS 6798) any above ground condensate drain pipe sections should be run and insulated as described above. See Fig 7

Unheated Internal Areas

Internal condensate drain pipes run in unheated areas, e.g. lofts basements and garages, should be treated as external pipe.

Ensure the customer is aware of the effects created by a frozen condensate and is shown where this information can be found in the user manual.

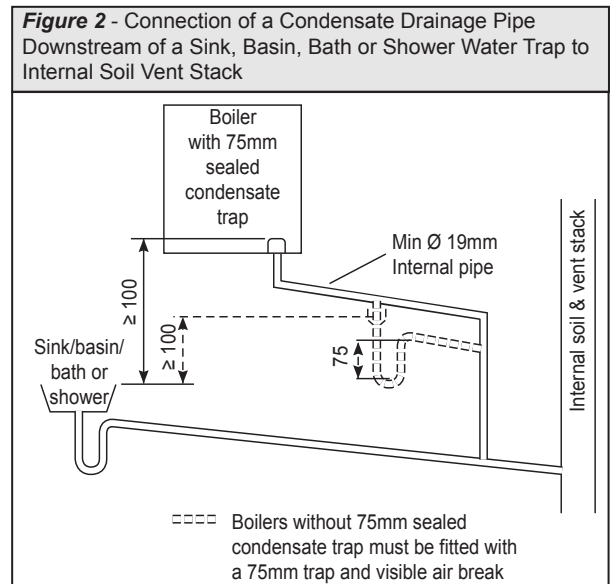
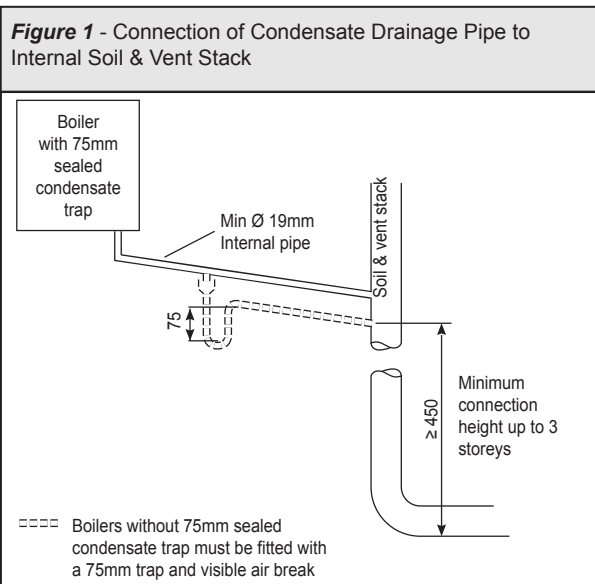

continued

22 CONDENSATE DRAIN - CONT'D.....

Figure 3 - Connection of a Condensate Pump Typical Method (see manufacturers detailed instructions)

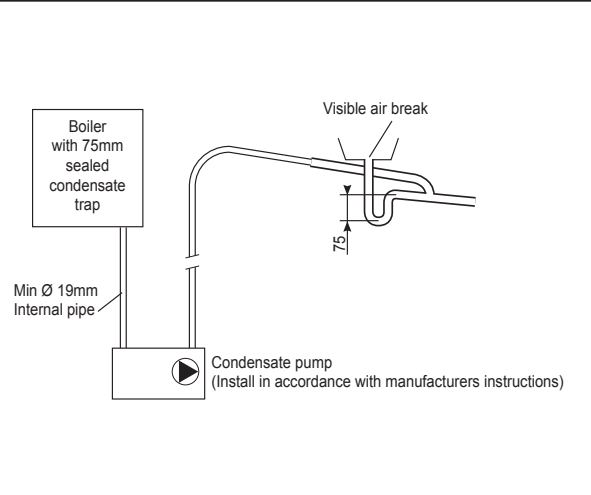

Figure 4 - Connection of condensate Drainage Pipe to External Soil & Vent Stack

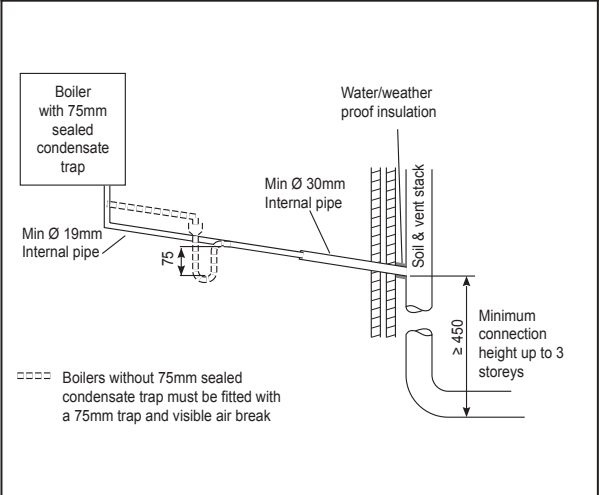

Figure 5 - Connection of a Condensate Drainage Pipe to an External Rainwater Downpipe (only combined foul/rainwater drain)

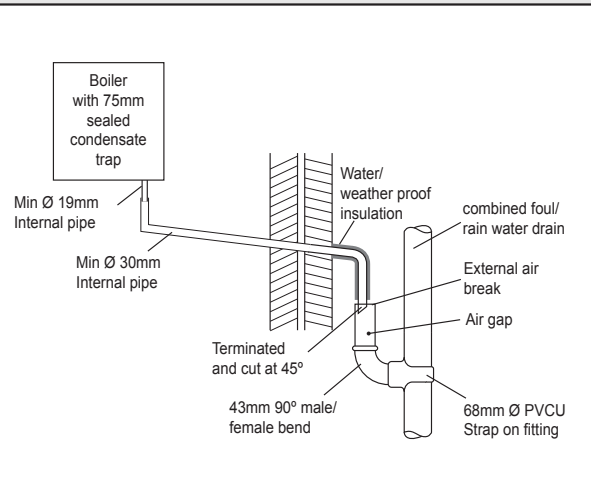

Figure 6 - Connection of Condensate Drainage Pipe Upstream of a Sink, Basin, Bath or Shower Waste Trap to External Drain, Gully or Rainwater Hopper

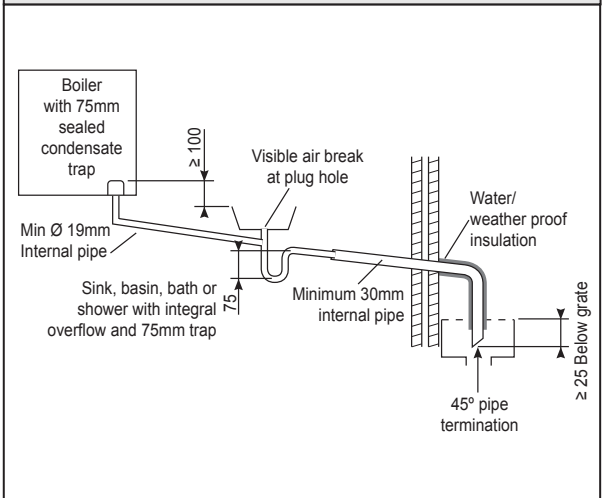
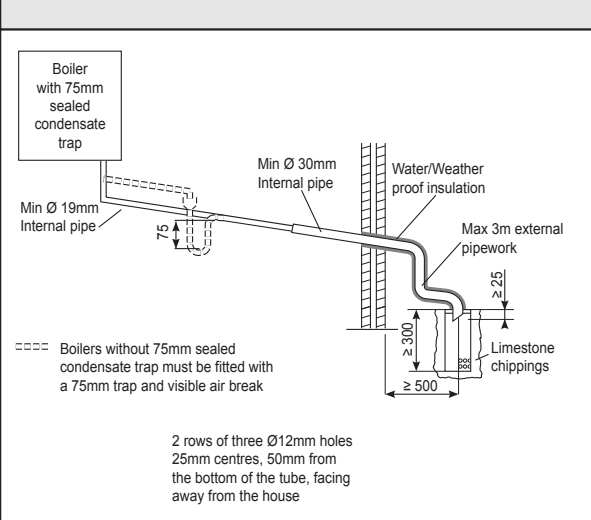

Figure 7 - Connection of a Condensate Drainage Pipe to an External Purpose Made Soak Away.



INSTALLATION

23 CONNECTIONS & FILLING

NOTES.

Ensure all boss blanking plugs are removed before connecting hardware. Each valve must be fitted to the correct boss as shown in the picture.

Ensure each union is fitted with fibre seals provided. Do not subject any of the isolating valves to heat as the seals may be damaged.

WATER CONNECTIONS CH

1. Connect the CH flow service valve provided in the hardware pack to the threaded boss connection provided at the lower rear of the boiler.
2. Connect the CH return valve.
3. For boiler outputs of 18, 24 & 30:
If connecting the boiler to heating loads in excess of 60,000 Btu/h, connecting flow and return heating systems pipework must be sized in 28mm diameter at the point of pipe connection to the boiler tails. Use 22mm x 28mm pipe adaptors as appropriate.

GAS CONNECTION

IMPORTANT. The gas service cock is sealed with a non-metallic blue fibre washer, which must not be overheated when making capillary connections. Refer to Frame 1 for details of the position of the gas connection.

For additional gas supply information refer to "Gas Supply" on page 8.

SAFETY VALVE DRAIN

The safety valve connection, located at the bottom right-hand side of the boiler, comprises a 15mm diameter stub pipe.

Installer to provide a compression joint on the end of the stub pipe. This assists with pipe removal when servicing.

The discharge pipe should be positioned so that the discharge of water or steam cannot create a hazard to the occupants of the premises or damage the electrical components and wiring.

Note. An optional safety valve wall outlet kit is available if required.

FILLING

IMPORTANT - when filling:

- A. Ensure the dust cap on air vent located at the rear of the pump chamber is slightly unscrewed.
- B. When filling, there may be a slight water leak from the air vent therefore electrical connections should be protected.

1. Ensure that the CH isolating handles are open.
2. Fill and vent the system. Refer to Frame 2 for filling and setting pressure procedure.
3. Check for water soundness.

Note.
On low pressure installations ensure the pump is full of water before initial lighting.

Dust Cap

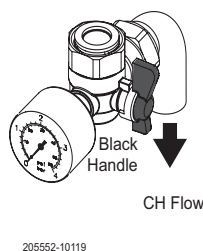
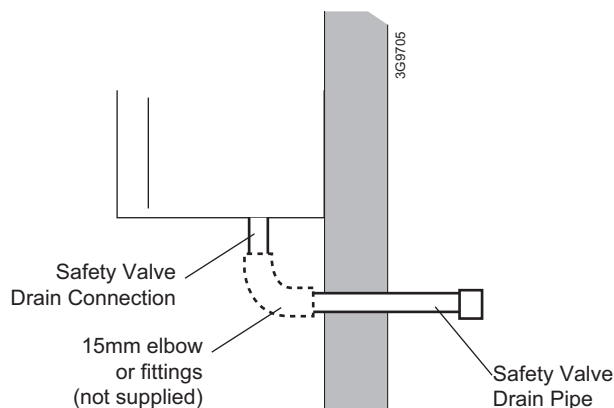

Note that all isolation handles are shown in the open position.

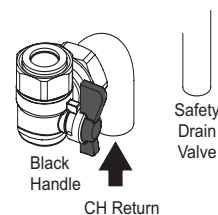
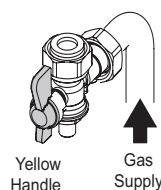

24 ELECTRICAL CONNECTIONS

WARNING. This appliance MUST be earthed.

A mains supply of 230Vac ~ 50 Hz is required.

The fuse rating should be 3A. All external controls and wiring must be suitable for mains voltage.

Wiring external to the boiler MUST be in accordance with the current I.E.E. (BS.7671) Wiring Regulations and any local regulations.

Wiring should be 3 core PVC insulated cable, not less than 0.75mm² (24 x 0.2mm), and to BS 6500 Table 16. For IE reference should be made to the current ETCI rules for electrical installations.

Connection must be made in a way that allows complete isolation of the electrical supply such as a double pole switch having a 3mm (1/8") contact separation in both poles. The means of isolation must be accessible to the user after installation.

25 INTERNAL WIRING

The Logic System IE boiler comes pre-fitted with 1.8m of mains cable. This must be connected to a permanent live supply and NOT switched by thermostats/programmers. For installers wishing to change this cable refer to Frame 26.

Connecting the Switched Live to the Boiler

1. Consult the Y Plan and S Plan diagrams below.
2. Isolate the mains supply to the boiler
3. Remove the front panel. Refer to Frame 8.
4. Swing the control box down into the servicing position.
5. Route incoming cable through a grommet in the bottom panel (note that the grommets are "blind" and will require puncturing) and secure using the clamp and screws provided in the hardware pack.
6. Connect the switched live to the terminal block as shown.

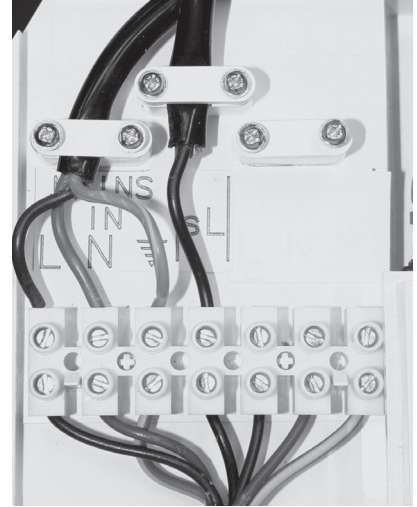

FROST THERMOSTAT - WIRING

If parts of the system are vulnerable to freezing or the programmer is likely to be left off during cold weather, a frost stat should be fitted in conjunction with a pipe thermostat.

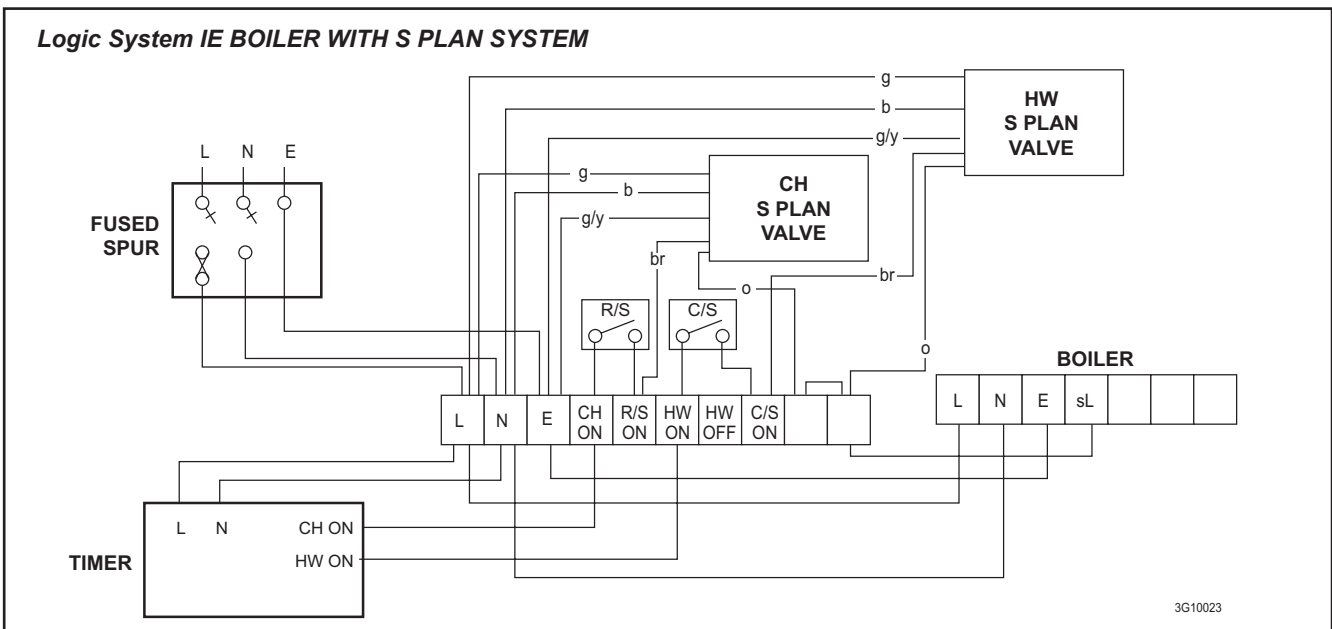
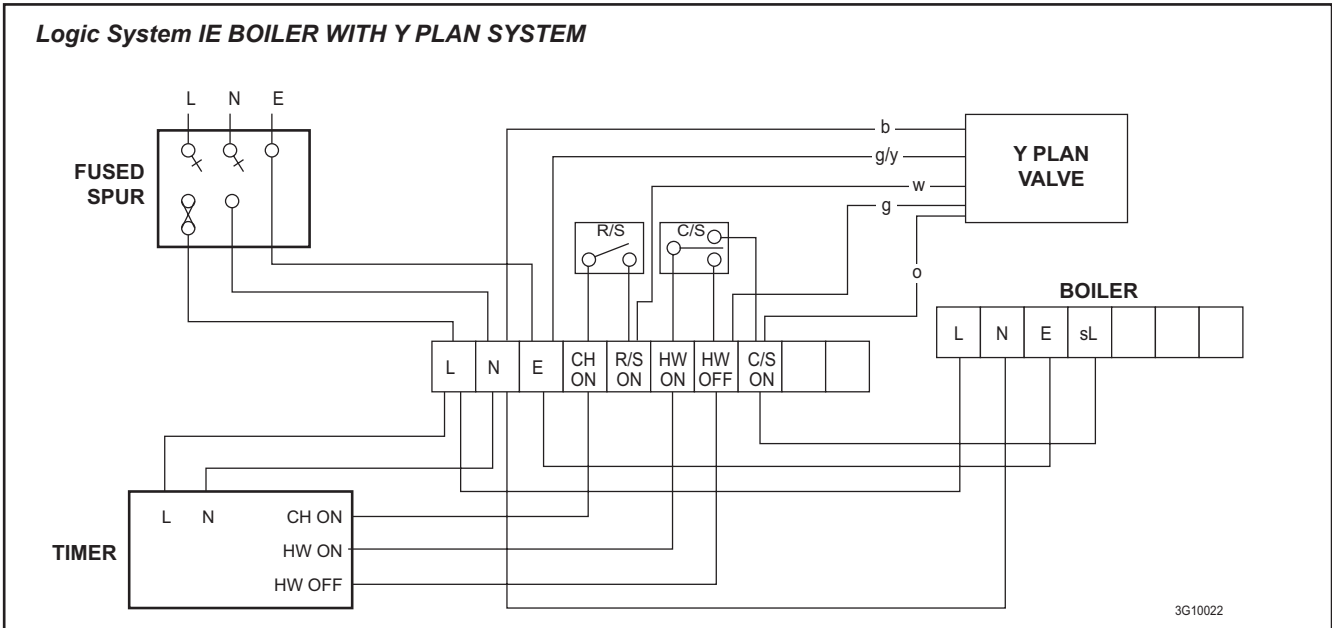

26 REPLACING PRE-FITTED MAINS CABLE

If it is necessary to use an alternative mains cable to the one pre-fitted then use the following guide.

Replacement wiring should comply with notes in Frame 24.

1. Isolate the mains supply to the boiler.
2. Remove the front panel. Refer to Frame 35.
3. Swing the control box down into the service position. Refer to frame 41.
4. Remove the live, neutral and earth wires from the terminal block.
5. Loosen the cable clamp and withdraw the mains cable.
6. Route replacement cable back through the cable clamp and grommet and re-tighten to provide cord anchorage.
7. Connect the live, neutral and earth wires to the terminal strip. When making the mains electrical connections to the boiler it is important that the wires are prepared in such a way that the earth conductor is longer than the current carrying conductors, such that if the cord anchorage should slip, the current carrying conductors become taut before the earthing conductor.
8. Swing the control box back up into the operating position and re-fit the front panel ensuring a good seal is made.



27 EXTERNAL ELECTRICAL CONTROLS

Wiring External to the Boiler

The fuse rating should be 3A.

Wiring external to the boiler **MUST** be in accordance with the current I.E.E. (BS.7671) Wiring Regulations and any local regulations.

Frost Protection

If parts of the pipework run outside the house or if the boiler will be left off for more than a day or so then a frost thermostat should be wired into the system.

The frost thermostat should be sited in a cold place but where it can sense heat from the system.

Note. *If the boiler is installed in a garage it may be necessary to fit a pipe thermostat, preferably on the return pipework.*

28 WIRING DIAGRAM

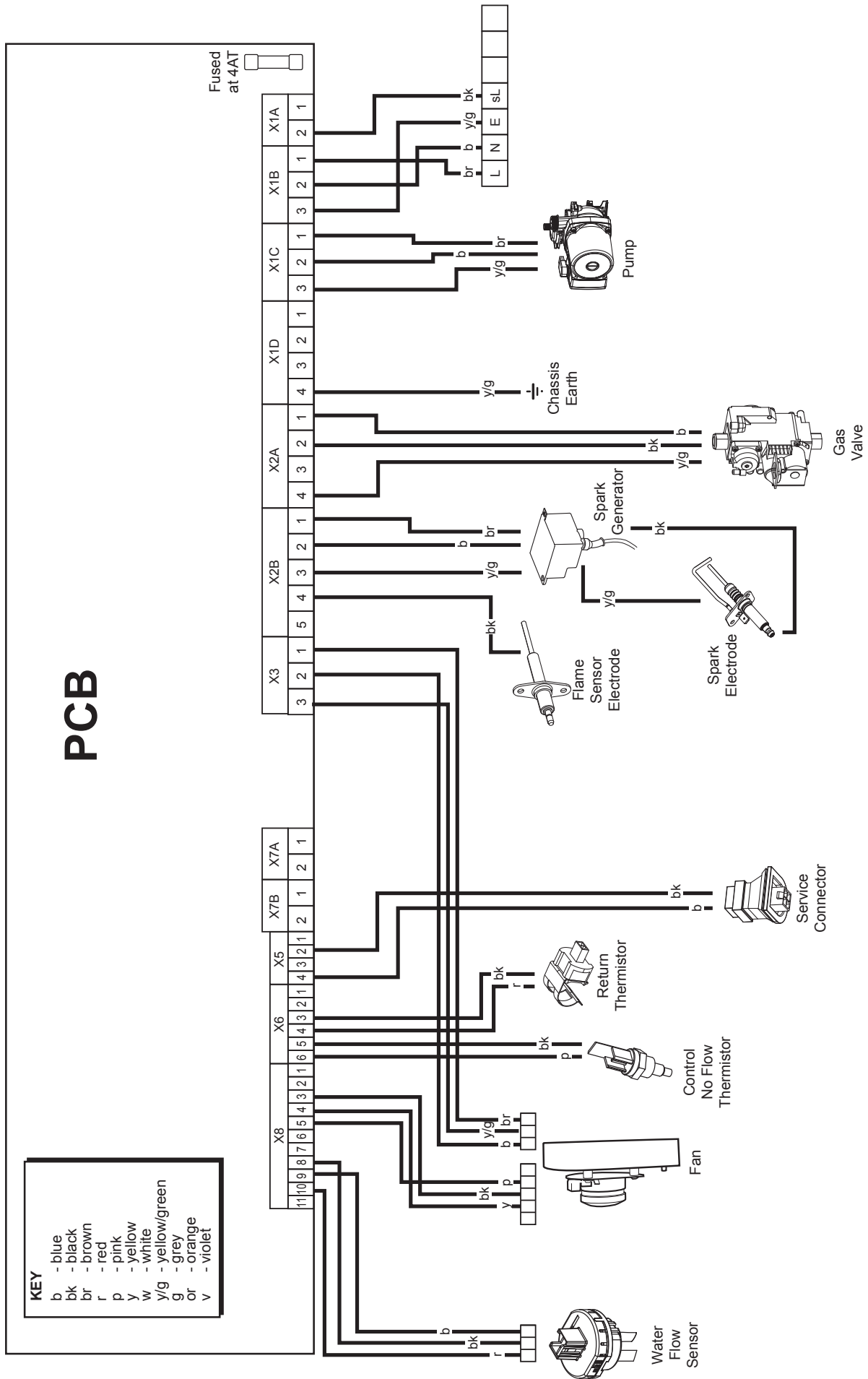

29 COMMISSIONING AND TESTING

A. Electrical Installation

1. Checks to ensure electrical safety should be carried out by a competent person.
2. ALWAYS carry out the preliminary electrical system checks, i.e. earth continuity, polarity, resistance to earth and short circuit, using a suitable test meter.
3. After wiring the boiler, all grommets in the bottom panel MUST be in place to ensure that boiler case sealing is maintained.

B. Gas Installation

1. The whole of the gas installation, including the meter, should be inspected and tested for tightness and purged in accordance with the recommendations of BS. 6891. In IE refer to IS.813:2002.
2. Purge air from the gas installation by the approved methods only.

WARNING. Whilst effecting the required gas tightness test and purging air from the gas installation, open all windows and doors, extinguish naked lights and **DO NOT SMOKE.**

GENERAL

Please Note: The combustion for this appliance has been checked, adjusted and preset at the factory for operation on the gas type defined on the appliance data plate. **DO NOT** adjust the air/gas ratio valve.

Having checked:

- That the boiler has been installed in accordance with these instructions.
- The integrity of the flue system and the flue seals, as described in the Flue Installation section.

Proceed to put the boiler into operation as follows:

CHECK THE OPERATIONAL (WORKING) GAS INLET PRESSURE

Set up the boiler to operate at maximum rate.

With the boiler operating in the maximum rate condition check that the operational (working) gas pressure at the inlet gas pressure test point complies with the requirements - refer to "Gas Supply" on page 8.

Ensure that this inlet pressure can be obtained with all other gas appliances in the property working.

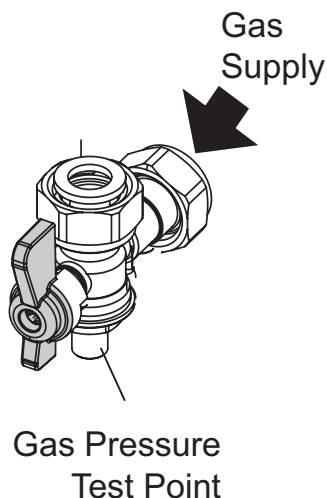

As part of the commissioning process, the combustion of this appliance must be checked and the Benchmark Checklist completed. A flow chart to assist is provided on page 59.

ATTENTION !
IT IS A CONDITION OF THE MANUFACTURERS WARRANTY THAT THE BENCHMARK COMMISSIONING CHECKLIST IS FULLY COMPLETED AND LEFT WITH THE APPLIANCE

30 INITIAL LIGHTING

Legend

- A. CH temperature control
- B. Mode Control Knob
- C. Boiler Status
- D. Burner 'on' indicator
- E. CH Flow Isolating Valve
- F. Pressure Gauge
- G. Gas Inlet Pressure Test Point
- H. Gas Service Cock
- J. CH Return Isolating Valve
- K. Drain Valve

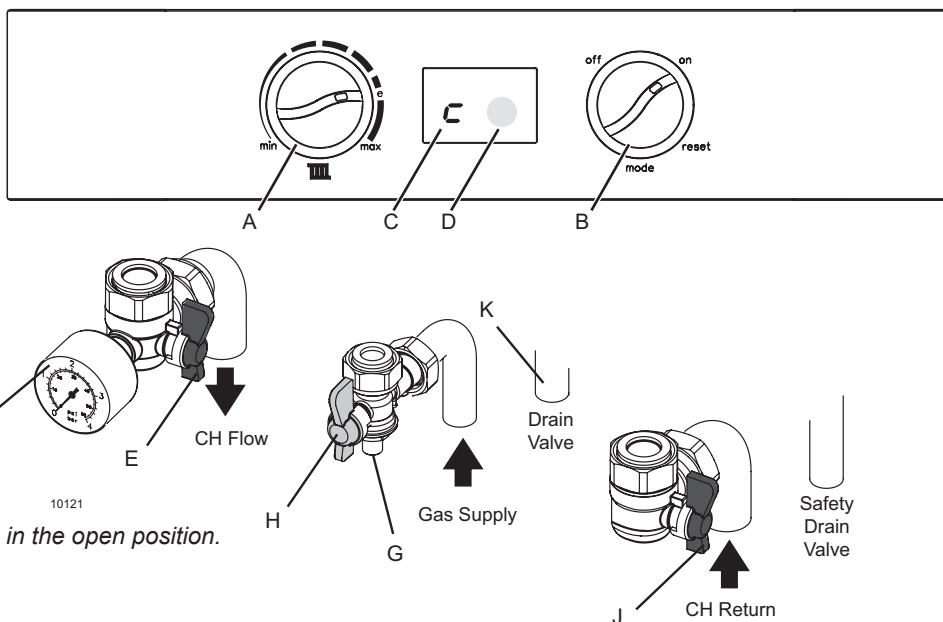

Note. Valves shown are in the open position.

1. Check that the system has been filled and that the boiler is not airlocked. Ensure the automatic air vent cap is open. Refer to Frame 28.

Note.

It is important the burner is not operated before the system is fully vented of air. If it is necessary to operate the appliance pump to assist venting of the air this must be done with the gas service cock turned off.

2. Refit the boiler front panel. Refer to Frame 35.
3. Check that the drain valve (K) is closed and that the CH isolating valve (E and J) are OPEN.
4. Check that the electrical supply is OFF.
5. Check that the boiler mode control knob (B) is off.
6. Check that the gas service cock (H) is OPEN.
7. Slacken the screw in the inlet pressure test point (G) and connect a gas pressure gauge via a flexible tube.
8. Switch the electricity supply ON and check all external controls are calling for heat.

CENTRAL HEATING

9. Set the CH temp control (A) to max and turn the mode control knob (B) to ON. The boiler control should now go through its ignition sequence until the burner is established.
10. If the boiler does not light after 5 attempts the boiler will lock out and display fault code $L-2$ constantly. Reset the boiler (Refer to Frame 32). The boiler will repeat its ignition sequence. If reset occurs 5 times within 15 minutes then $L-5$ will be shown. If power is removed this will be reset.

When the burner is established the BLUE 'Burner On' neon (D) will be illuminated, the LED display (C) will show status C .

11. Ensure that with the boiler operating the dynamic gas pressure is able to obtain maximum output. Refer to Table 2.

IMPORTANT

The gas input to the burner is regulated by the gas valve according to the air flow produced by the fan. It is NOT user-adjustable. Any interference to sealed settings on the gas valve will adversely affect operation and render our warranty void.

For additional gas supply information refer to "Gas Supply" on page 8.

THE DISPLAY

The user control has one neon and one display to inform the user about the status. The display will show the status of the boiler. The neon will show the status of the flame. If no flame is detected the neon is off. When the flame is detected the neon will be lit permanently.

Below is a list with display function in normal operation.

- \emptyset Standby, no demand for heat present.
- c Boiler is active for central heating or hot water.
- F Boiler is active for boiler frost protection.
- L Boiler is in lockout for a specific error. Display will be blinking, alternating with a number or letter to show which error is detected.
- F Boiler has a fault for a specific error. Display will be blinking, alternating with a number or letter to show which error is detected.

Note: Boiler frost protection - boiler fires if temperature is below 5 degrees C.

Note. The boiler incorporates a fan overrun cycle which MUST NOT be prematurely interrupted by isolation of the mains electricity supply.

INSTALLATION

31 GENERAL CHECKS Make the following checks for correct operation:

CENTRAL HEATING (CH) MODE

1. Ensure that the CH external controls are calling for heat.

The display should read: c ☀

2. Check the boiler gas rate when the boiler is at full output.

Check at the gas meter, with no other appliance in use. Refer to Table 2 for gas rate.

3. Set the central heating external controls to OFF. The burner should go off and the pump continue to run for 4 minutes

The display should read: \square

4. Check the correct operation of the timer and all other system controls. Operate each control separately and check that the main burner responds.

WATER CIRCULATION SYSTEM

1. With the system COLD, check that the initial pressure is correct to the system design requirements.
For pre-pressurised systems, this should normally be 1.0 bar if sufficient system filling pressure is available.
 2. With the system HOT, examine all water connections for soundness. The system pressure will increase with temperature rise but should not exceed 2.5 bar.
 3. With the system still hot, turn off the gas, water and electricity supplies to the boiler and drain down to complete the flushing process.
- Note:** A flushing solution should be used during the flushing procedure.
Flushing solutions: Fernox Superfloc, Sentinel X300 (new systems) or X400 (existing systems). Refer to Frame 4.
4. Refill and vent the system, add inhibitor (see Frame 4), clear all air locks and again check for water soundness.
 5. Reset the system initial pressure to the design requirement.
 6. Balance the system. Refer to Frame 3.
 7. Check the condensate drain for leaks and check that it is discharging correctly.
 8. Finally, set the controls to the User's requirements.

Note: The pump will operate briefly as a self-check once every 24 hours in the absence of any system demand.

WATER TEMPERATURES

Temperatures can be selected using the CH temperature control (A)

Knob Setting	CH Flow Temp °C (°F)
Max	80 (176)
Min	30 (86)

32 RESET PROCEDURE

To reset boiler, turn the mode control knob (B) to reset position and immediately turn knob back to required setting. The boiler will repeat the ignition sequence if a heat demand is present.

Legend

- A. CH temperature control
- B. Mode Control Knob
- C. Boiler Status
- D. Burner 'on' indicator

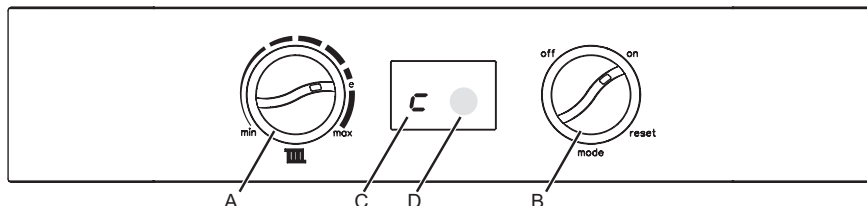

33 HANDING OVER

After completing installation and commissioning of the system the installer should hand over to the householder by the following actions:

1. Hand the User Instructions to the householder and explain his/her responsibilities under the relevant national regulations.
 2. Explain and demonstrate lighting and shut down procedures.
 3. The operation of the boiler and the use and adjustment of all system controls should be fully explained to the householder, to ensure the greatest possible fuel economy consistent with the household requirements of both heating and hot water consumption.
Advise the User of the precautions necessary to prevent damage to the system and the building, in the event of the system remaining inoperative during frosty conditions.
 4. Explain the function and the use of the boiler heating controls.
 5. Explain the function of the boiler fault mode.
Emphasise that if a fault is indicated refer to "Fault Codes" in the User Guide.
 6. Explain and demonstrate the function of time and temperature controls, radiator valves etc., for economic use of the system.
 7. If a timer is fitted draw attention to the timer Users Instructions and hand them to the householder.
 8. Loss of system water pressure
Explain that the dial underneath the boiler indicates the central heating system pressure and that if the normal COLD pressure of the system is seen to decrease over a period of time then a water leak is indicated. Explain the re-pressurising procedure and if unable to re-pressurise or if the pressure continues to drop a registered local heating installer should be consulted.
 9. Explain Boiler reset procedure.
 10. After installation and commissioning please complete the Benchmark Commissioning Checklist before handover to the customer. For IE, it is necessary to complete a "Declaration of Conformity" to indicate compliance to I.S. 813:2002.
- IMPORTANT**
11. A comprehensive service should be carried out ANNUALLY.
Stress the importance of regular servicing by a Gas Safe Registered Engineer. In IE servicing work must be carried out by a Registered Gas Installer (RGII).
 12. Inform the householder of the guarantee/registration found within the envelope pack and the requirement to register it to receive the full benefit of the warranty.

34 SERVICING SCHEDULE

For the very latest copy of literature for specification & maintenance practices, visit our website www.idealboilers.com, where you will be able to download the relevant information. N.B. Technical Bulletins are also available on www.idealboilers.com.

WARNING. Always turn OFF the gas supply at the gas service cock, and switch OFF and disconnect the electricity supply to the appliance before servicing.

Combustion testing must be carried out by a competent person using a combustion analyser conforming to BS7927.

To ensure the continued safe and efficient operation of the appliance it is recommended that it is checked at regular intervals and serviced as necessary. The frequency of servicing will depend upon the installation condition and usage but should be carried out at least annually.

It is the law that any service work must be carried out by a Gas Safe Registered Engineer. In IE service work must be carried out by a Registered Gas Installer (RGII).

INSPECTION

1. Light the boiler and carry out a pre-service check, noting any operational faults.
2. Check the flue terminal (and terminal guard if fitted) is undamaged and clear of any obstruction.
3. Check all water and gas joints for signs of leakage. Remake any suspect joints ensuring a gas tightness check is carried out if applicable and the water system is correctly refilled, vented and re-pressurised.

CLEANING PROCEDURE

Note. In order to carry out either servicing or replacement of components the boiler front panel must be removed. Refer to Frame 35.

1. Clean the main burner. Refer to Frame 37.
2. Clean the heat exchanger & condensate trap/siphon. Refer to Frames 38 & 39.
3. Check the main injector for blockage or damage. Refer to Frame 36.
4. Check that the flue terminal is unobstructed and that the flue system is sealed correctly.

The cleaning procedures are covered more fully in Frames 36-40 and MUST be carried out in sequence.

IMPORTANT.

6. After completing the servicing or exchange of components always test for gas tightness.
7. When work is complete the front panel MUST be correctly refitted, ensuring that a good seal is made.

Do NOT OPERATE the boiler if the front panel is not fitted.

8. If, for any reason, the condensate trap/siphon has been removed ensure the trap is refilled with water before reassembling.
9. Check the gas consumption.
10. Check combustion by connecting the flue gas analyser to the flue gas sampling point as shown in the diagram and measure CO & CO₂.

If the CO/CO₂ ratio is greater than 0.004 AND the integrity of the complete flue system and combustion circuit seals have been verified and the inlet gas pressure (and gas rate) have been verified, then contact Ideal.

11. Complete the service section in the Benchmark Commissioning Checklist.

GENERAL

Please Note: During routine servicing, and after any maintenance or change of part of the combustion circuit, the following must be checked:

- The integrity of the flue system and the flue seals,
- The integrity of the boiler combustion circuit and the relevant seals
- The operational (working) gas inlet pressure at maximum rate.
- The gas rate
- The combustion performance.

COMPETENCE TO CARRY OUT THE CHECK OF COMBUSTION PERFORMANCE

Please Note: BS 6798:2009 Specification for installation and maintenance of gas-fired boilers of rated input not exceeding 70kW net advises that:

- The person carrying out a combustion measurement should have been assessed as competent in the use of a flue gas analyser and the interpretation of the results.
- The flue gas analyser used should be one meeting the requirements of BS7927 or BS-EN50379-3 and be calibrated in accordance with the analyser manufacturers requirements, and
- Competence can be demonstrated by satisfactory completion of the CPA1 ACS assessment, which covers the use of electronic portable combustion gas analysers in accordance with BS7967, Parts 1 to 4.

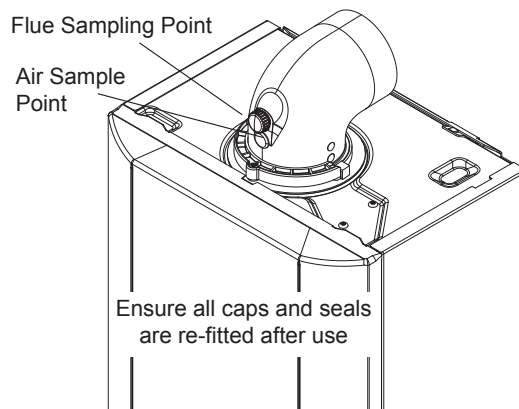

SERVICING

35 BOILER FRONT PANEL REMOVAL / REPLACEMENT

REMOVAL

1. Loosen the two screws retaining the front panel.
2. Pull the two spring clips down to disengage and pull panel forward and upward and remove.

REPLACEMENT

3. Hook the panel onto the top retaining clips.
4. Push the panel until the 2 bottom spring clips engage ensuring the 4 control knobs line up with the holes in the front panel.
5. Re-tighten the two retaining screws.

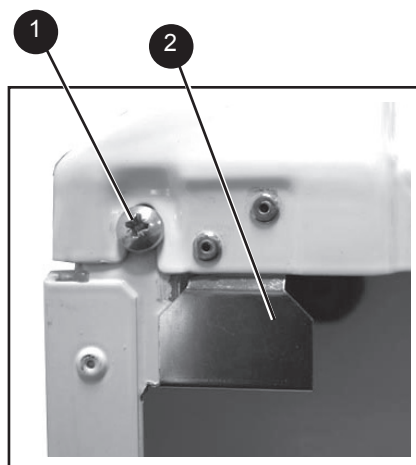

view from bottom of boiler

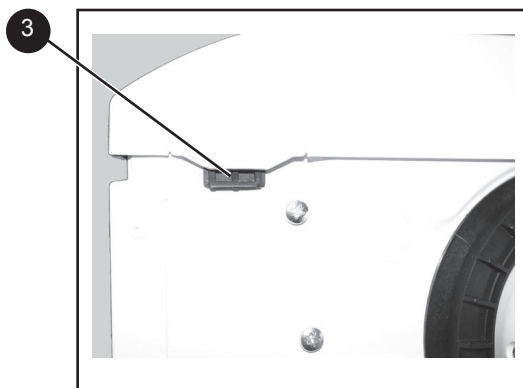

view from top of boiler

36 FAN AND VENTURI ASSEMBLY REMOVAL AND CLEANING

1. Disconnect the electrical leads from the fan.
2. Undo the gas pipe union connection to the injector housing.
3. Remove the extended nut on the fan mounting bracket.
4. Lift off fan and venturi assembly.
5. Inspect the injector for blockage or damage.
6. Inspect fan outlet sealing gasket and replace if necessary.

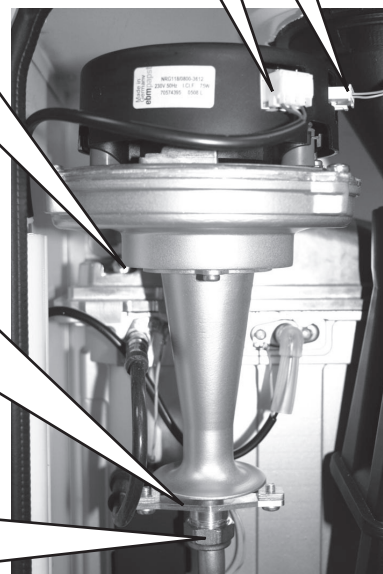
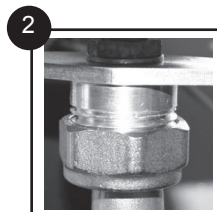
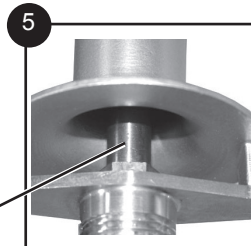
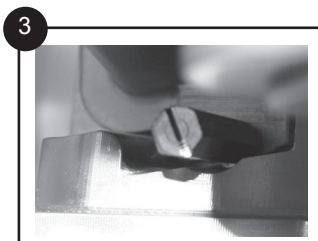

37 BURNER REMOVAL AND CLEANING

1. Ensure the sump is fully drained
2. Undo the two screws and remove the sump cover retaining the lower flue manifold.
3. Lift the manifold to clear the bottom sealing gasket and remove manifold.
4. Remove the 2 burner front fixing screws and loosen the 2 rear extended nuts by at least ten turns.
5. Lift off the burner from the combustion chamber. To facilitate the removal angle the burner as shown.

IMPORTANT

The burner head is a ceramic plaque construction. Care must be taken to ensure that **the burner is not placed down upon its face** as this may cause damage to the ceramic.

6. Brush off any deposits that may be on the ceramic with a SOFT brush.
7. Inspect the sealing gasket around the burner for any signs of damage. Replace as necessary.

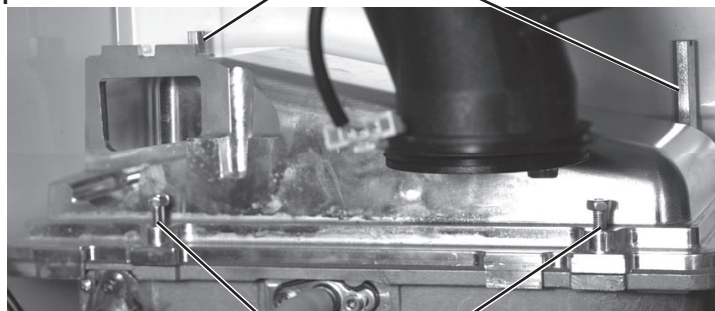
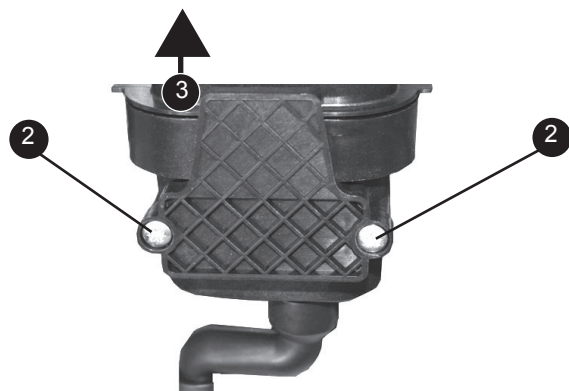
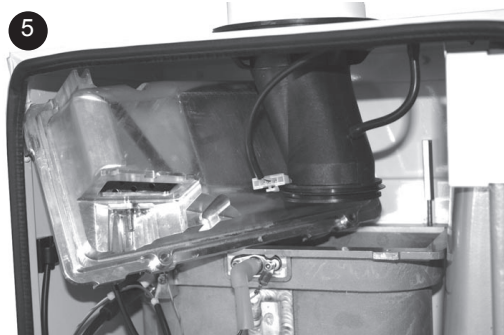

38 CLEANING THE CONDENSATE TRAP/SIPHON

1. Pull off the rubber pipe at the sump drain.
2. Disconnect the condensate drain pipe.
3. Turn the siphon clockwise to disengage and lift to remove.

Note. Keep siphon upright when removing

4. Clean siphon with water.
 5. Re-assemble in reverse order.
- B When re-assembling ensure the trap is full of water.

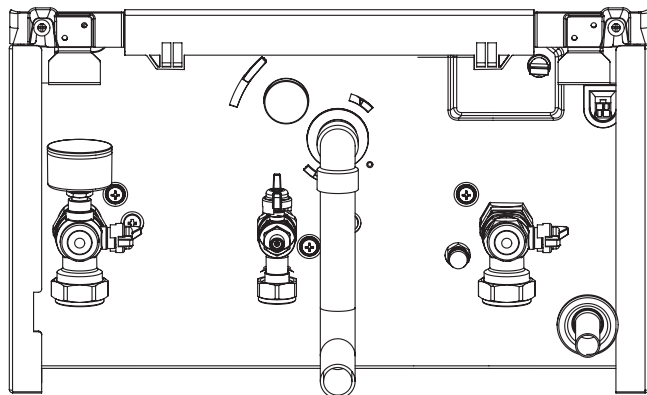

39 CLEANING THE HEAT EXCHANGER

Note: Ensure the condensate trap/siphon is fully drained before cleaning. Refer to Frame 50.

1. Remove ignition and flame detection electrodes. Refer to Frames 46 & 47.
2. It is advisable to replace the sump cover prior to the water flush process.
3. Thoroughly flush the heat exchanger by pouring water into the top of the combustion chamber ensuring the full top area is covered.
4. Remove the sump cover and clean loose deposits from the sump.
5. Inspect the ignition and detection electrodes. Ensure that they are clean and in good condition - replace if necessary.
6. Re-fit the ignition and flame detection electrodes, ensuring that both earth tabs are fitted to ignition electrode.
7. Check that the ignition and detection gaps are correct. Refer to Frames 46 & 47.

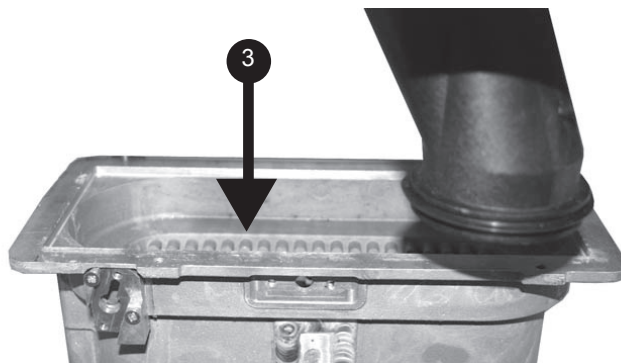
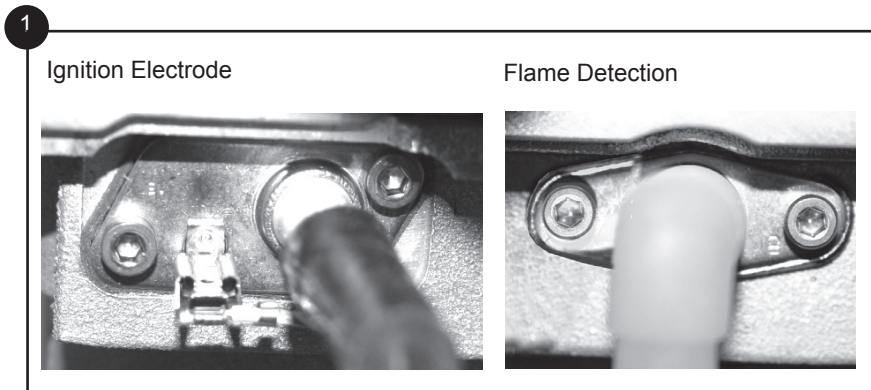

40 REASSEMBLY

Reassemble the boiler in the following order:

1. Ensure that the condensate trap/siphon is full of water.
2. Refit the burner ensuring the sealing gasket is correctly positioned and free from damage (tighten the 4 fixing screws in the sequence shown below).
3. Refit the fan / venturi assembly ensuring the retaining tabs are correctly positioned and the sealing gasket is correctly positioned and free from damage.
4. Reconnect the fan electrical leads.
5. Remove the sump cover and refit the lower flue manifold as shown.
6. Refit the sump cover.
7. Refit the boiler front panel.

IMPORTANT. Ensure that the boiler front panel is correctly fitted and that a good seal is made.
8. Swing the control box back into its working position and secure.
9. Turn on the gas supply at the gas service cock.
10. Reconnect the electrical supply.
11. Check the operation of the boiler. refer to Frame 30 & 31.

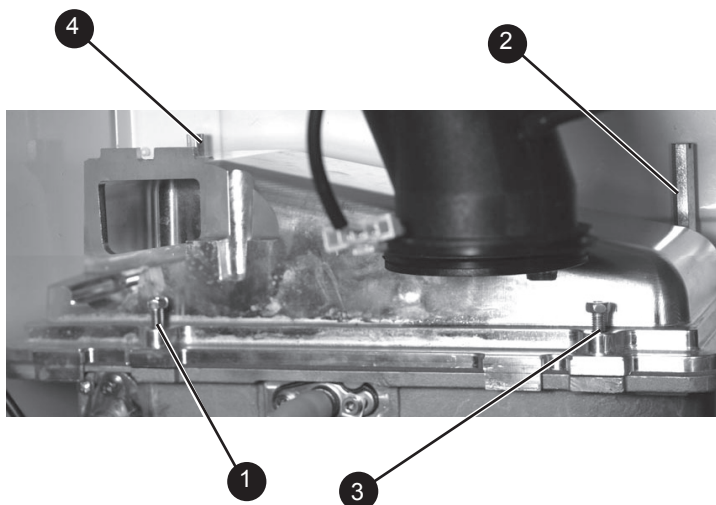

SERVICING

41 REPLACEMENT OF COMPONENTS

GENERAL

When replacing ANY component

1. Isolate the electricity supply.
2. Turn off the gas supply.
3. Remove the boiler front panel. Refer to Frame 35.
4. Release the retaining clip and swing the control box down into its servicing position.

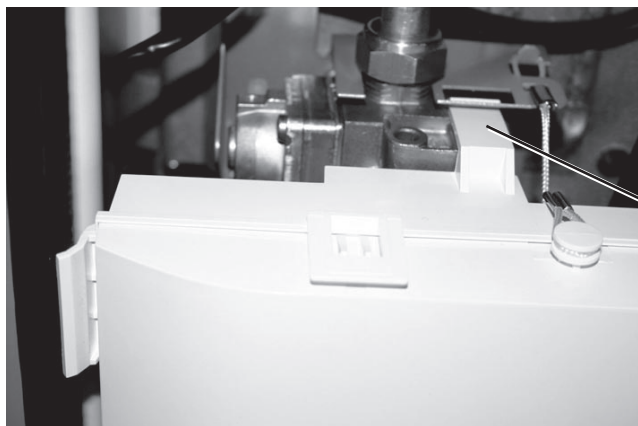

After replacing ANY component check operation of the boiler, including gas soundness, gas rate and combustion test.

IMPORTANT.

When work is complete, the front panel must be correctly refitted - ensuring that a good seal is made.

Notes.

1. In order to assist fault finding, the control panel has an LED diagnostic display. The key to boiler fault conditions is shown in Frame 63.
2. In order to replace components in Frames 54-61 it is necessary to drain the boiler. Refer to Frame 53.

THE BOILER MUST NOT BE OPERATED WITHOUT THE FRONT PANEL FITTED

42 FAN REPLACEMENT

1. Refer to Frame 41.
2. Disconnect the electrical leads from the fan.
3. Undo the gas pipe union connection to the injector housing.
4. Remove the extended nut retaining the fan mounting bracket.
5. Lift and remove the fan and venturi assembly.
6. Remove the screw and twist venturi anti-clockwise to remove venturi assembly, *noting the orientation of the venturi in relation to the fan body.*
7. Transfer the venturi assembly to the new fan, replacing the 'o' ring if evidence of damage or deterioration is visible.
8. Fit the new fan / venturi assembly ensuring the retaining tabs are correctly positioned and the fan outlet sealing gasket is correctly positioned and free from damage. Refit the extended nut.
9. Reassemble the boiler in reverse order, taking care not to overtighten the screw on the fan mounting bracket.
10. Check the operation of the boiler. Refer to Frames 30 & 31.

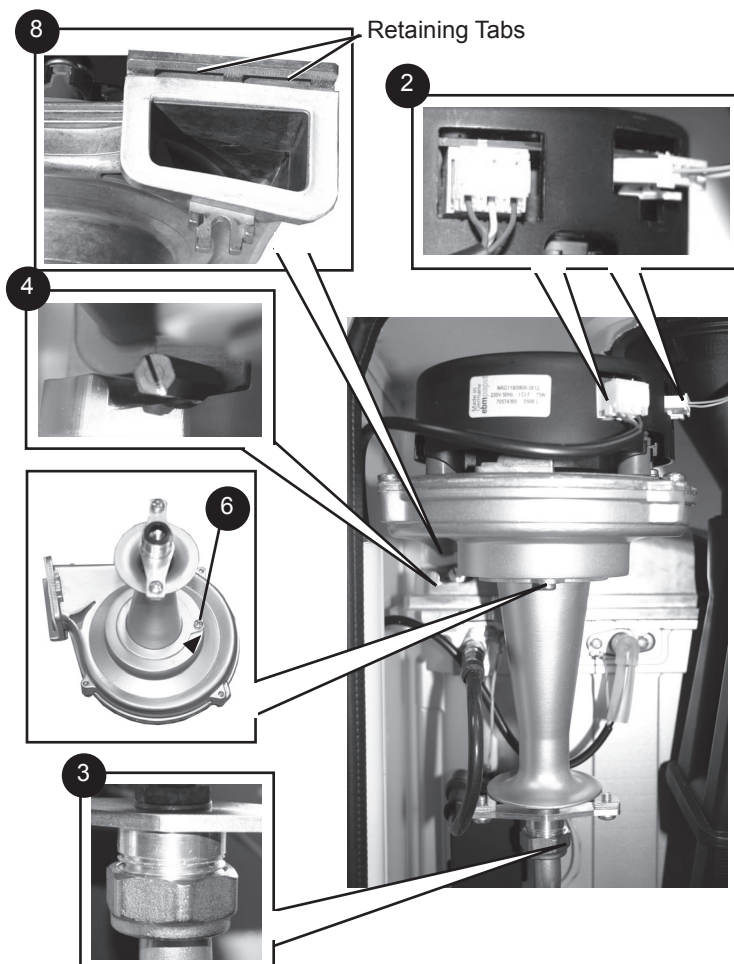

43 BURNER INJECTOR REPLACEMENT

1. Refer to Frame 41.
2. Disconnect the electrical leads from the fan.
3. Undo the gas pipe union connection to the injector housing.
4. Loosen the screw retaining the fan mounting bracket.
5. Lift and remove the fan and venturi assembly.
6. Remove the 2 injector housing screws.
7. Withdraw the injector housing.
8. Fit the new injector housing complete with injector.
9. Reassemble in reverse order, ensuring that the new gas seal supplied is located correctly in the injector housing.
10. Check operation of the boiler. Refer to Frames 30 & 31.

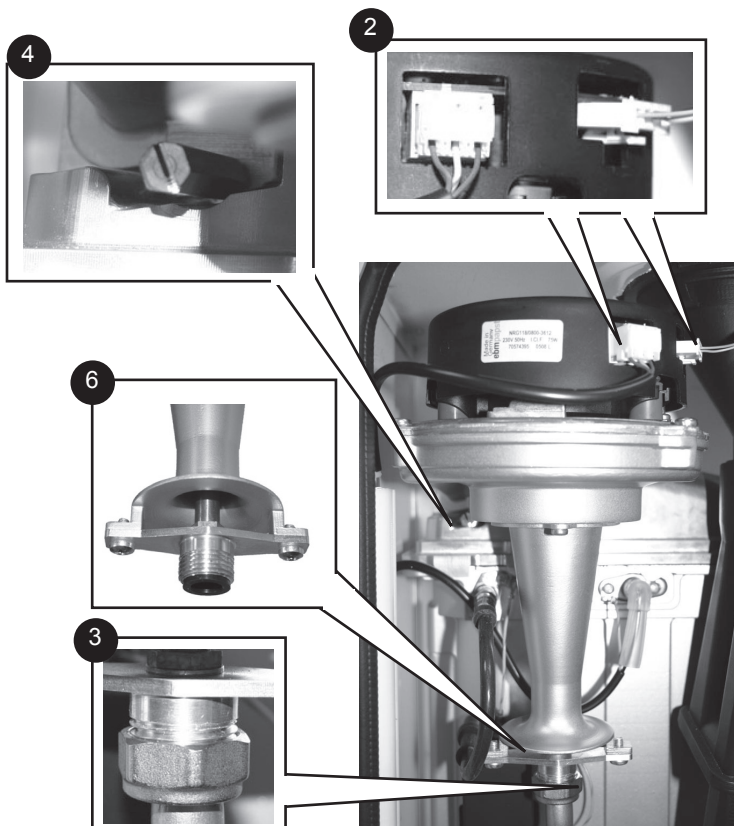

44 BURNER REPLACEMENT

1. See Frame 43.
2. Refer to Frame 41.
3. Undo the two screws and remove the sump cover.
4. Lift the manifold to clear the bottom sealing gasket and remove manifold.
5. Remove the 2 front fixing screws and loosen the 2 rear extended nuts.
6. Lift off the burner from the combustion chamber. To facilitate the removal angle the burner as shown.
7. Fit the new burner, replacing any damaged or deteriorating sealing gasket.
8. Reassemble in reverse order. Refer to Frame 40.
9. Check the operation of the boiler. Refer to Frames 30 & 31.

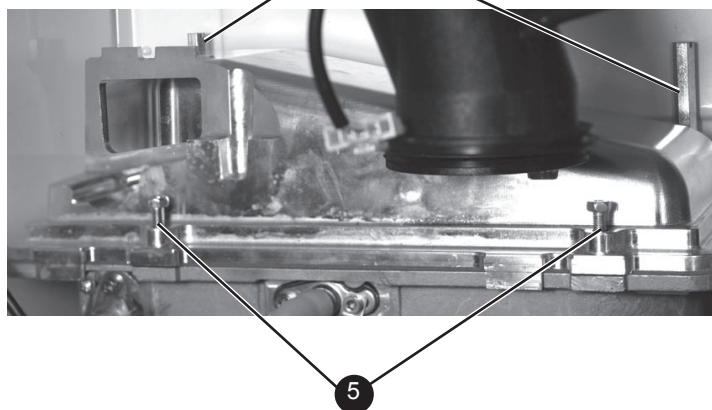
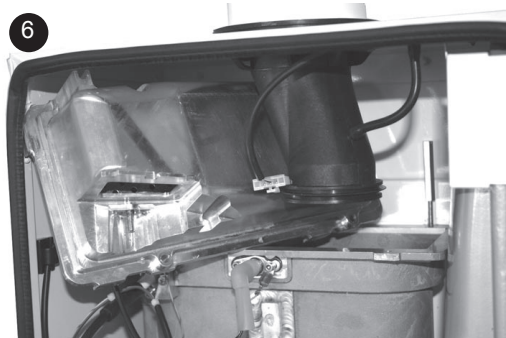
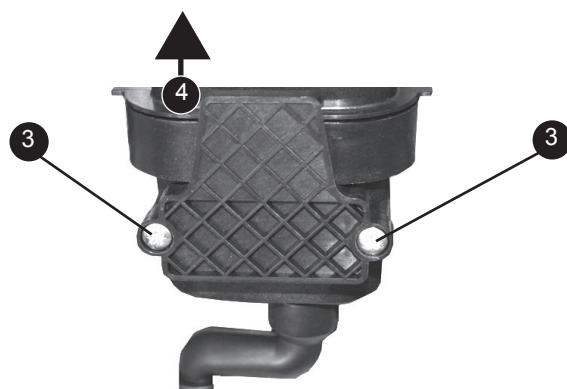

45 RETURN THERMISTOR RENEWAL

1. Refer to Frame 41.
2. Unclip the return thermistor from the return pipe and withdraw it from the boiler.
3. Disconnect the electrical leads from the thermistor.
4. Reconnect the electrical lead to the new thermistor and reassemble in reverse order, ensuring that the thermistor is securely fitted to the pipe on the thermistor locator tab as shown.
6. Check the operation of the boiler. Refer to Frames 30 & 31.

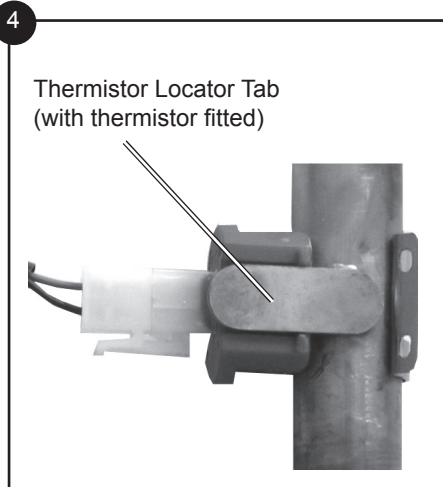
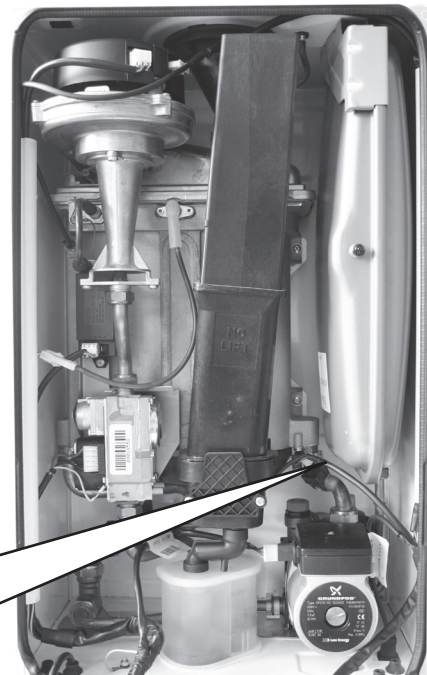

46 IGNITION ELECTRODE REPLACEMENT

1. Refer to Frame 41.
2. Remove the burner. Refer to Frame 44.
3. Unplug the ignition lead from the electrode.
4. Remove the earth lead from the ignition electrode.
5. Remove the 2 screws holding the ignition electrode to the combustion chamber.
6. Remove the electrode.
7. Fit the new ignition electrode, using the new gasket supplied. Check dimensions as shown.
8. Reassemble in reverse order.
9. Check the operation of the boiler. Refer to Frames 30 & 31.

Ignition Electrode

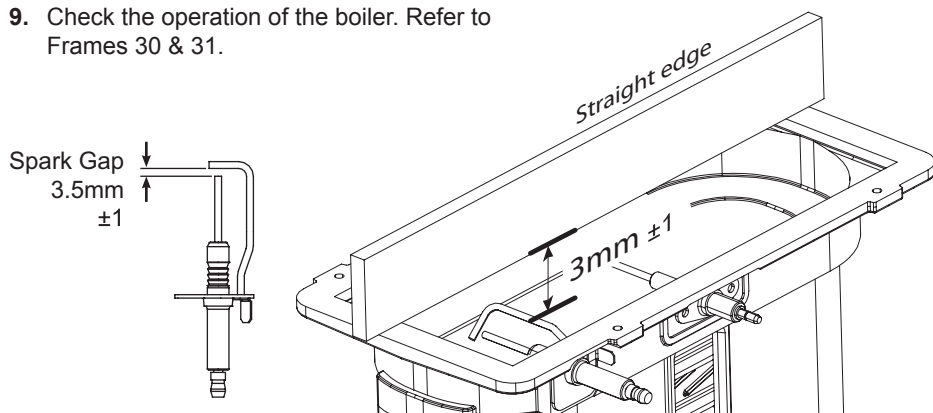
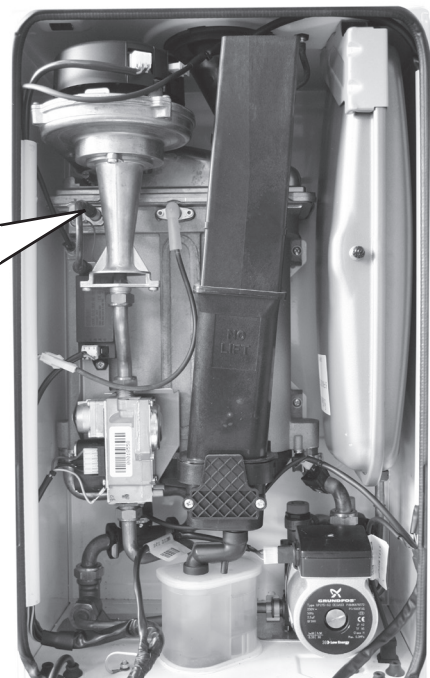
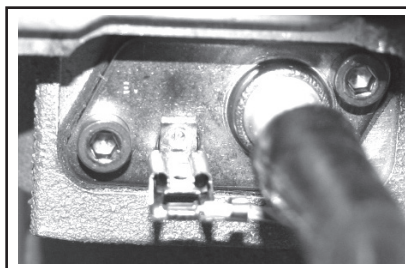

47 FLAME DETECTION ELECTRODE REPLACEMENT

1. Refer to Frame 41.
2. Remove the burner. Refer to Frame 44.
3. Unplug the flame detection lead from the electrode.
4. Remove the 2 screws retaining the detection electrode.
5. Remove the electrode.
6. Fit the new flame detection electrode, using the new gasket supplied.
7. Reassemble in reverse order.
8. Check the operation of the boiler. Refer to Frames 30 & 31.

Flame Detection Electrode

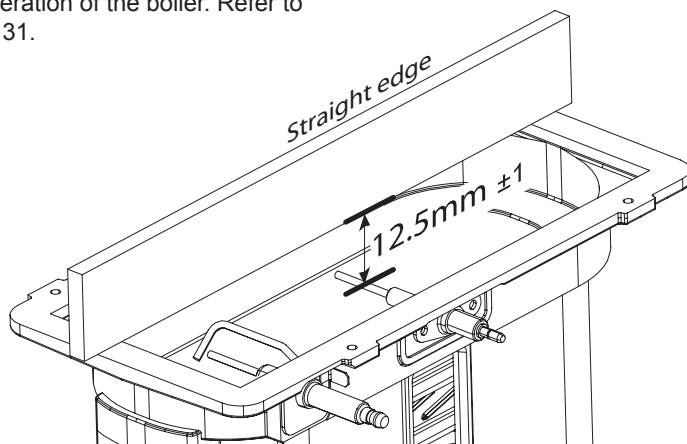
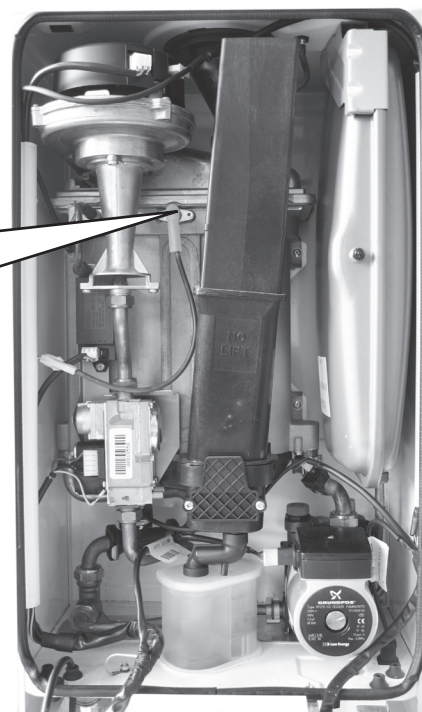
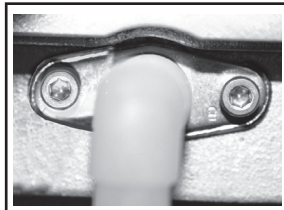

48 SPARK GENERATOR REPLACEMENT

1. Refer to Frame 41.
2. Disconnect the leads from the spark generator.
3. Remove the M5 screws securing the spark generator to the boiler chassis.
4. Fit the new spark generator and re-assemble in reverse order ensuring the two earth leads are correctly replaced.
5. Check operation of the boiler. Refer to Frames 30 & 31.

Spark Generator

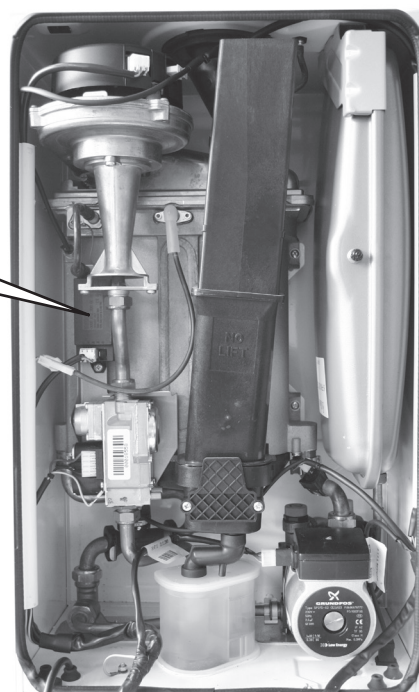
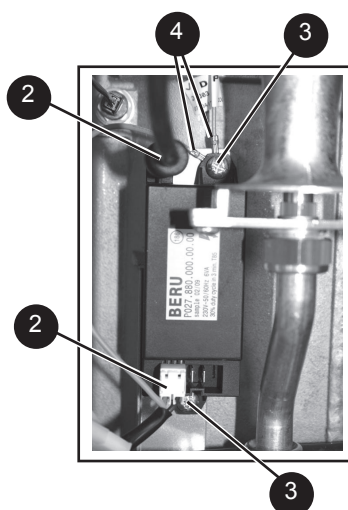

49 GAS CONTROL VALVE REPLACEMENT

1. Refer to Frame 41.
2. Unplug the electrical lead connection from the gas control valve and disconnect the earth wire.
3. Undo the union nut on the outlet of the gas control valve.
4. Undo the gas inlet pipe union at the inlet to the gas control valve.
5. Loosen the back nut retaining the valve to the bracket and withdraw the valve forwards.
6. Fit the new gas control valve ensuring the two sealing washers are in place and reconnect gas and electrical connections.
7. Check operation of the boiler. Refer to Frames 30 & 31.

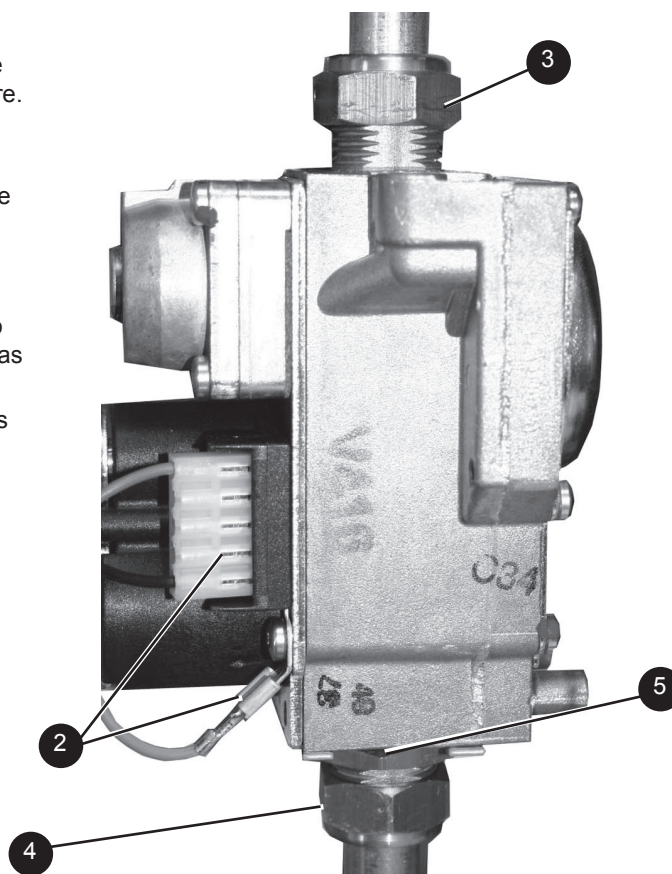

50 CONDENSATE TRAP/SIPHON REPLACEMENT

1. Refer to Frame 41.
2. Pull off the rubber pipe at the sump drain.
3. Disconnect the condensate drain pipe.
4. Turn the siphon clockwise to disengage and lift to remove.

Note. Keep siphon upright when removing

5. Clean siphon with water.
6. Re-assemble in reverse order.
7. When re-assembling ensure the trap is full of water.
8. Check operation of the boiler. Refer to Frames 30 & 31.

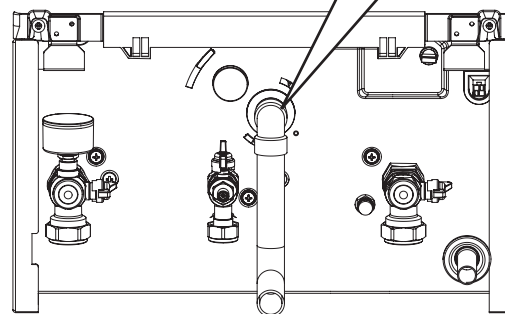
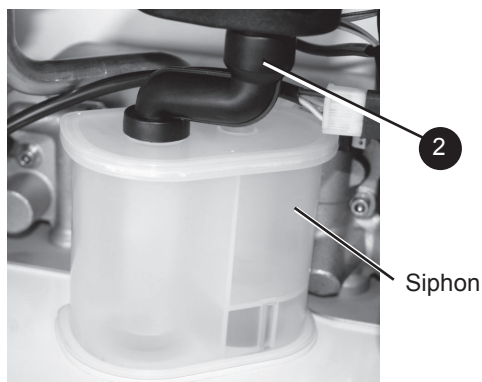

51 MAIN PCB REPLACEMENT

Note that production boiler PCBs are factory pre-set to operate for boiler range and output, but when ordering Primary PCB as a spare, an additional Boiler Chip Card (BCC) MUST also be purchased for your specific boiler range and output.

Note. Fit the earth strap provided with the PCB to your wrist and secure to a suitable earth on the boiler chassis.

1. Refer to Frame 41.
2. Note the control knob positions.
3. Remove the 2 screws retaining the control box cover.
4. Carefully lift the 4 retaining clips and remove control box cover.
5. Unplug all lead connections to the PCB including the ribbon cable (to facilitate ribbon cable removal, ease side clips apart and pull upwards), also where applicable, push the small plastic clip with an electrical screwdriver to facilitate plug removal.
6. Spring out the two side retaining clips and pull the PCB upwards to clear the 4 corner retaining posts.
7. Take the new Primary PCB and attach the appropriate Boiler Chip Card (BCC) to it (this should correspond to the output of the boiler: 15kW, 18kW, 24kW or 30kW). **Note.** Ensure the correct orientation of BCC by placing "TOP" side up as shown.
8. Re-connect all plug connections.
9. Reassemble in reverse order.
10.
 - a. Turn power on
 - b. Displays "8" blue light on/off, "first digit input", "second digit input", "1st letter appliance type", i.e. "2", "4", "s"
 - c. Move knob to required setting (standby, summer, winter)

Note. If no BCC fitted on non programmed board items a & b will be displayed then "Boiler Type Card Fault - Contact Installer" The correct BCC for this appliance will need to be fitted.
11. Check operation of the boiler. Refer to Frames 30 & 31.

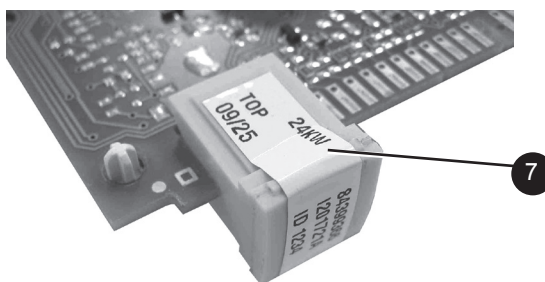
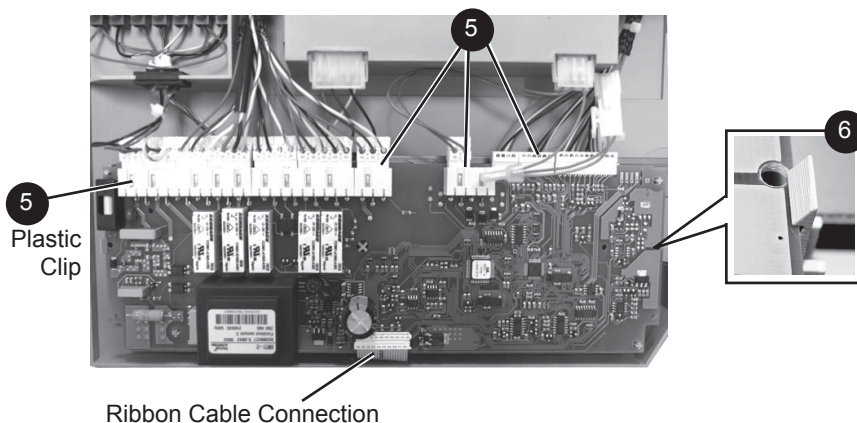
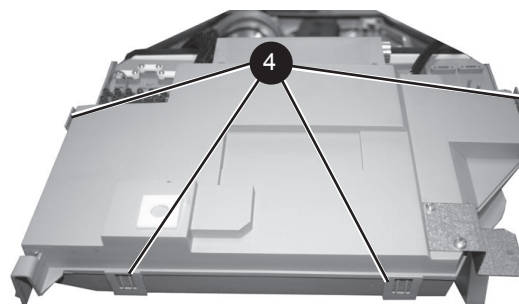
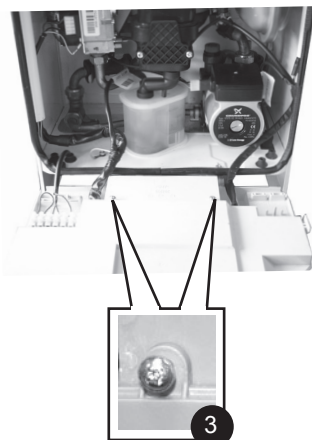

52 USER CONTROL PCB REPLACEMENT

Note. Fit the earth strap provided with the PCB to your wrist and a suitable earth on the boiler chassis.

1. Refer to Frame 41.
2. Remove the main PCB, refer to Frame 51.
3. Unclip the PCB and lift to clear the mounting posts.
4. Fit the new PCB ensuring the 4 potentiometer spindles line up with the control knobs which must be in a vertical position.
5. Reassemble in reverse order.
6. Check operation of the boiler. Refer to Frames 30 & 31.

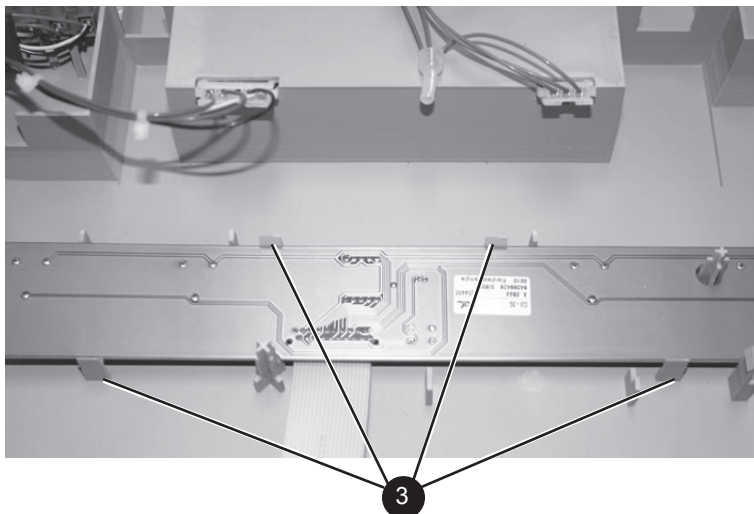

4

PCB

Control Knobs (to be in vertical position)

Potentiometer spindle

3G9954

53 DRAINING THE BOILER

CENTRAL HEATING CIRCUIT

1. Refer to Frame 41.
2. Close all the CH water isolating valves on the boiler inlet.
3. To drain the primary heat exchanger circuit: Open the drain valve and attach a length of hose to the CH drain point.
4. After replacing any component on the boiler, remove the hose, close the drain valve and open all system isolating valves (re-pressurise as appropriate) before proceeding to check operation of the boiler.
5. Check operation of the boiler. Refer to Frames 30 & 31.

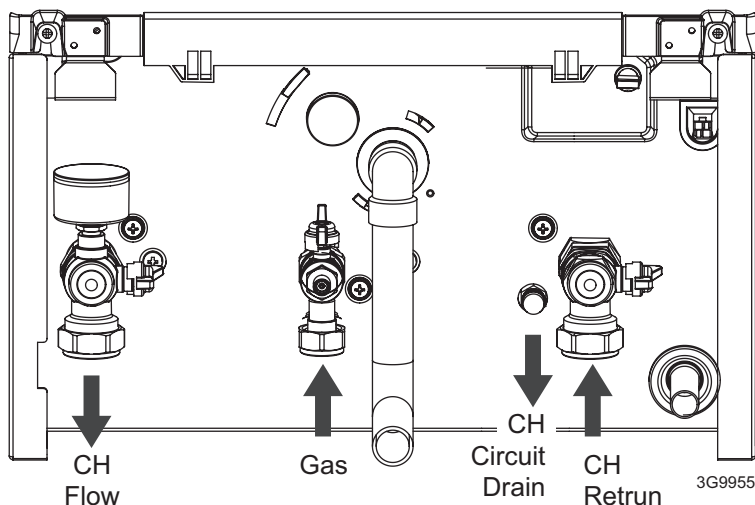

SERVICING

54 PRESSURE GAUGE RENEWAL

1. Refer to Frame 41.
2. Drain the heating system. Refer to Frame 53.
3. Unscrew the pressure gauge and discard.
4. Fit new pressure gauge, using suitable jointing compound.
5. Refill the boiler. Refer to Frame 23.
6. Check operation of the boiler. Refer to Frames 30 & 31.

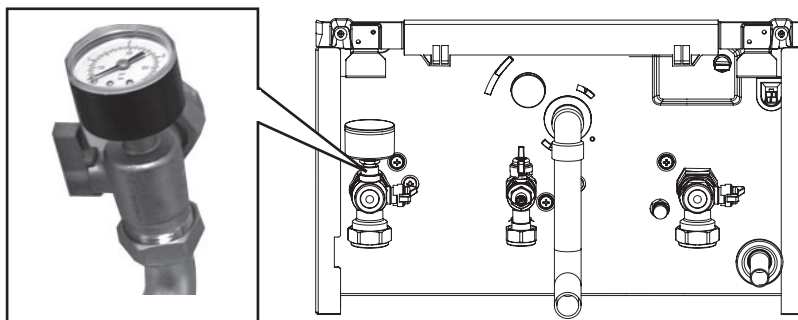

55 SAFETY RELIEF VALVE RENEWAL

1. Refer to Frame 41.
2. Drain the boiler. Refer to Frame 53.
3. Remove the condensate trap/siphon. Refer to Frame 50.
4. Remove expansion vessel. Refer to Frame 61.
5. Disconnect the electrical connection from the return thermistor.
6. Disconnect the 22mm pipe connection at the rear of the pump outlet.
7. Pull off the clip retaining the pipe to the heat exchanger swing the pipe to clear the pump and remove pipe.
8. Undo the safety valve union connection.
9. Withdraw the clip securing the safety valve.
10. Lift safety valve from boiler.
11. Fit the new safety valve and reassemble in reverse order ensuring the new 'o' ring is fitted to the top of the return pipe.
12. Refill boiler. Refer to Frame 28. Check operation of boiler. Refer to Frames 30 & 31.

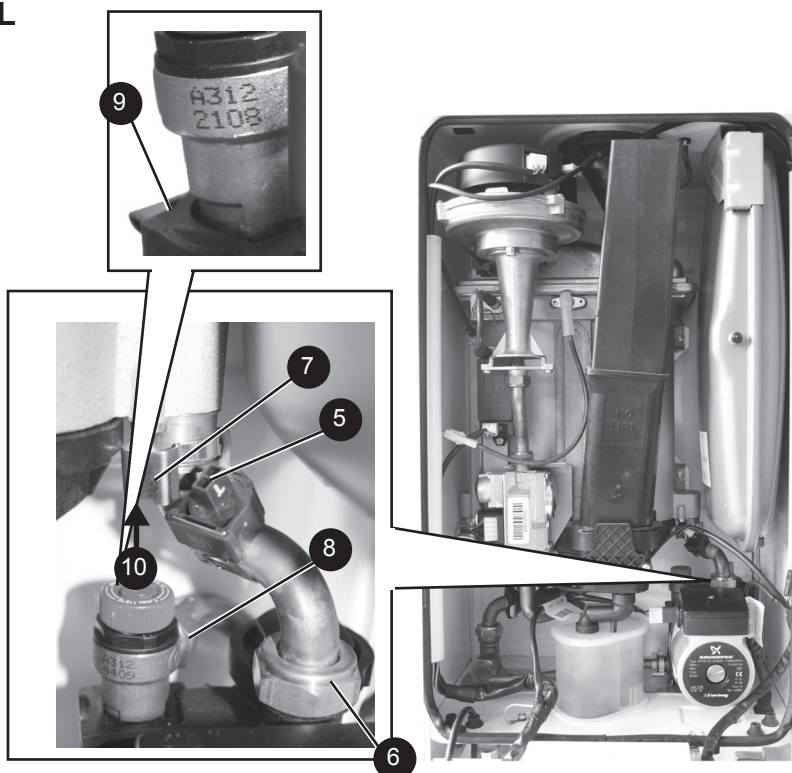

56 PUMP AUTOMATIC AIR VENT REPLACEMENT

1. Refer to Frame 41.
2. Drain the boiler. Refer to Frame 53.
3. Remove the expansion vessel. Refer to Frame 61.
4. Firstly, increase access area by disconnecting the 22mm pipe connection at top of pump chamber and bottom of heat exchanger and remove pipe Refer to Frame 55 (no's 5,6 & 7).
5. The automatic air vent head is retained in the pump body with a bayonet connection. The air vent head and float assembly is removed by turning the head anti-clockwise (viewed from above) and pulling upwards.
6. Reassembly is the reverse of the above. Ensure the air vent head 'o' ring seal is in place when refitting and the new 'o' ring is fitted to the return pipe top connection.
7. Ensure the air vent cap is loose.
8. Refill the boiler. Refer to Frame 23. Check for leaks around the new air vent joint.
9. Check the operation of the boiler. Refer to Frames 30 & 31.



57 PUMP HEAD REPLACEMENT

1. Refer to Frame 41.
2. Drain the boiler. Refer to Frame 53.
3. Disconnect the electrical lead from the pump.
4. Remove the 4 Allen screws retaining the pump head.
5. Remove the pump head.
6. Fit the new pump head.
7. Reassemble in reverse order.
8. Refill the boiler. Refer to Frame 23.
9. Check operation of the boiler. Refer to Frames 30 & 31.

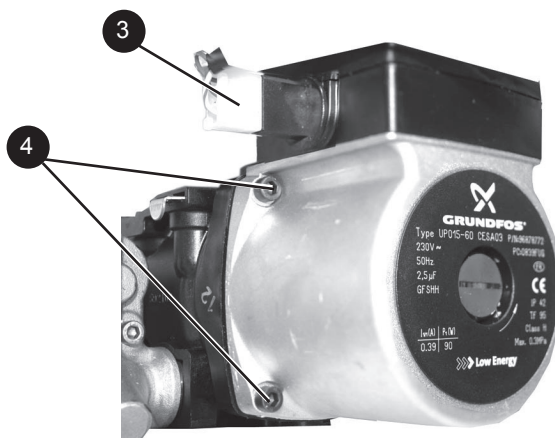

58 CH WATER PRESSURE SENSOR REPLACEMENT

1. Refer to Frame 41.
2. Drain the boiler. Refer to Frame 53.
3. Pull off the electrical connection
4. Turn the retaining collar anti-clockwise and pull the head from the housing.
5. Fit the new water flow switch head, ensuring the electrical lead connections wires point to the bottom of the boiler as shown.
6. Re-assemble in reverse order.
7. Re-fill the boiler. Refer to Frame 23.
8. Check the operation of the boiler. Refer to Frames 30 & 31.

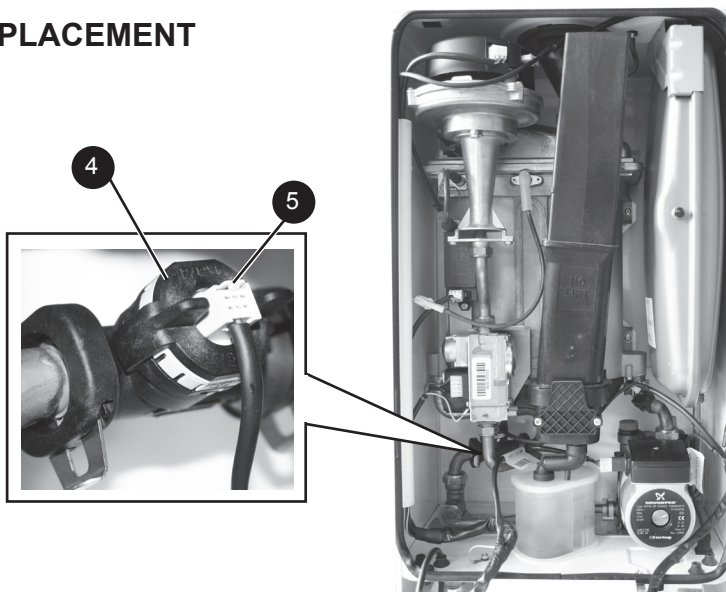

59 CONTROL / NO FLOW THERMISTOR REPLACEMENT

1. Refer to Frame 41.
2. Drain down the boiler. Refer to Frame 53.
3. Unplug the electrical lead.
4. Unscrew the thermistor (to facilitate removal a 13mm socket spanner should be used).
5. Fit the new thermistor using the sealing washer provided.
6. Reassemble in the reverse order.
7. Refill the boiler. Refer to Frame 23.
8. Check the operation of the boiler. Refer to Frames 30 & 31.

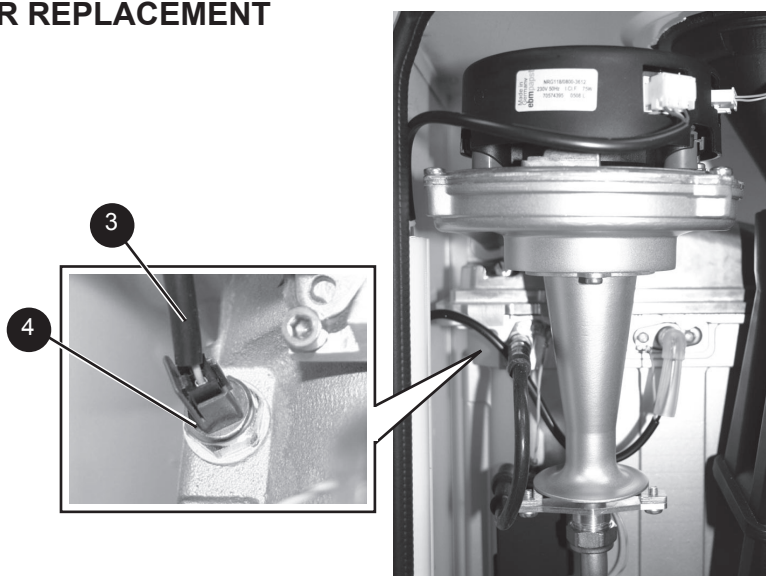

60 HEAT ENGINE RENEWAL

Refer also to Frame 5 - 'Boiler Exploded View'

IMPORTANT

Before starting the removal procedure, protect the gas and electrical controls with a waterproof sheet or plastic bag.

1. Refer to Frame 41.
2. Drain the boiler. Refer to Frame 53.
3. Remove the fan / venturi assembly and place on one side. Refer to Frame 42.
4. Remove the burner and place on one side. Refer to Frame 44.
5. Remove the ignition and detection electrodes. Refer to Frames 46 & 47.
6. Remove the spark generator. Refer to Frame 48.
7. Remove the gas valve. Refer to Frame 49.
8. Remove the expansion vessel. Refer to Frame 61.
9. Remove the control/no flow thermistor. Refer to Frame 59.
10. Remove the 2 M5 screws retaining the gas valve mounting bracket and transfer bracket to the new heat exchanger.
11. Undo the inlet pipe union nut and remove the retaining spring clip and remove pipe.
12. Undo the lower flow pipe union nut, withdraw 'c' clip from upper flow pipe connection and remove flow pipe/sensor assembly.
13. Remove the condensate rubber pipe. Refer to Frame 50, no. 2.
14. Remove the two heat exchanger fixing screws.
15. Remove the Heat exchanger.
16. Reassemble in reverse order, ensuring the heat exchanger LH retaining bracket is correctly positioned. Replace any new 'o' rings supplied with new heat exchanger and replacing gaskets or seals if any sign of damage is evident. When replacing the spring clips located on both the flow and return pipe connections, ensure clip is oriented to correctly match connecting pipe diameters.
17. Ensure the trap/siphon is filled with water. Refer to Frame 50.
18. Refill the boiler. Refer to Frame 23.
19. Check operation of the boiler. Refer to Frames 30 & 31.

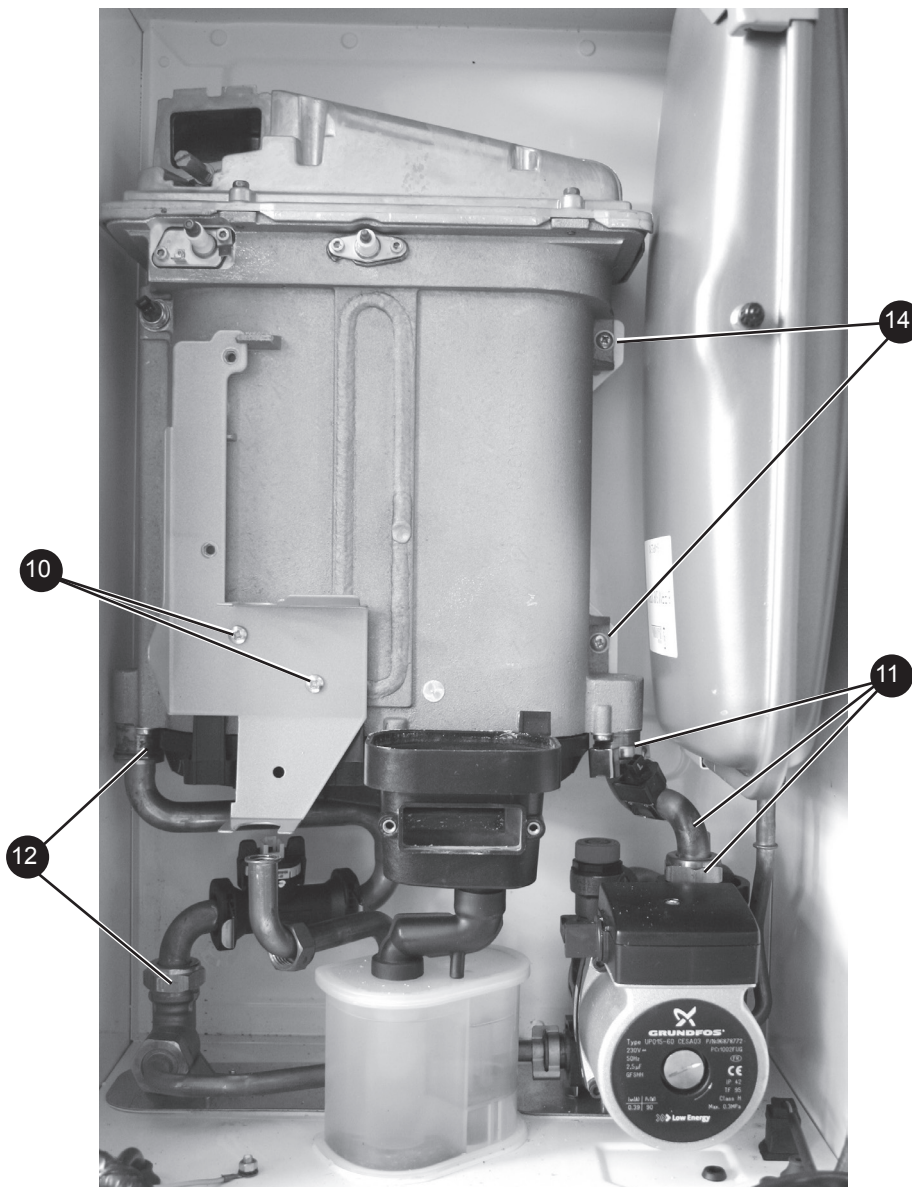

61 EXPANSION VESSEL RECHARGING & REPLACEMENT

RECHARGING

1. Remove the charge point cover.
2. Recharge the tank pressure to 0.75 bar.
3. Re-assemble in reverse order
4. Check operation of the boiler. Refer to Frames 30 & 31.

REPLACEMENT

5. Refer to Frame 41.
6. Drain the boiler CH circuit. Refer to Frame 53.
7. Unscrew the union nut on the vessel water connection pipe.
8. Support the expansion vessel and unscrew the 2 screws from the securing clamp, located on the top of the boiler, and remove. (Note the position of the bracket on the vessel)
9. Remove the expansion vessel.
10. Fit the new expansion vessel.
11. Reassemble in reverse order.
12. Refill the boiler. Refer to Frame 23.
13. Check operation of the boiler. Refer to Frames 30 & 31.

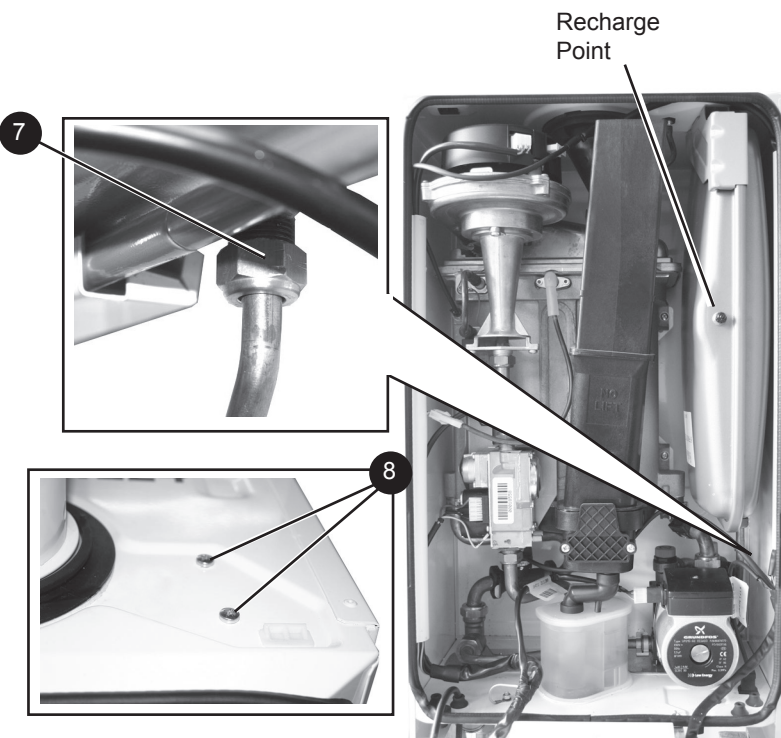

62 BOILER SEALING PANEL SEAL REPLACEMENT

1. Refer to Frame 41.
2. Remove the old seal from the casing and thoroughly clean the casing surfaces.
3. Fit the new seal, ensuring the bottom joint provides an air tight seal.
5. Reassemble in reverse order.
6. Check operation of the boiler. Refer to Frames 30 & 31.

Note. *Ensure that the boiler front panel is correctly sealed, compressing the seal to make an airtight joint.*

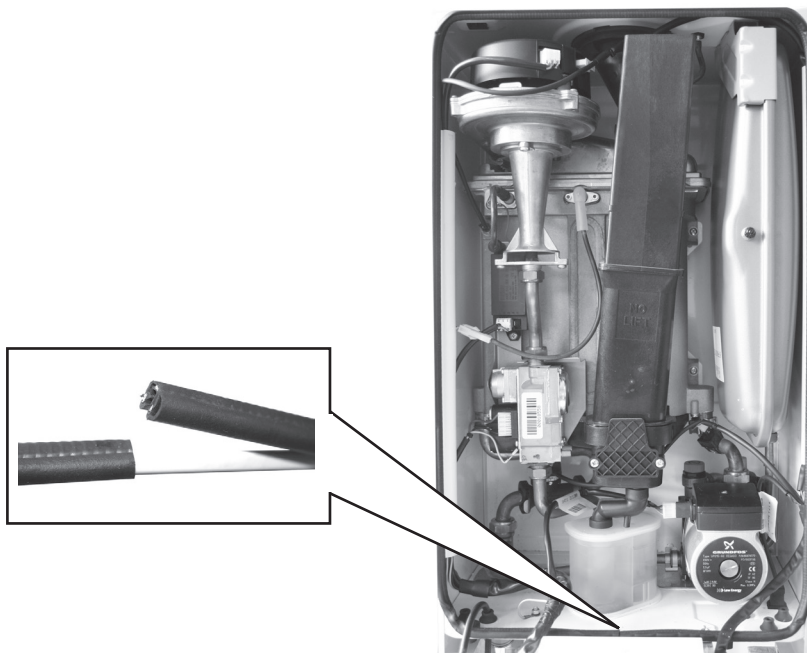

FAULT FINDING

63 FAULT FINDING CHART MAIN MENU

In order to assist fault finding the boiler has a 7 segment display. The key to the display codes is as follows:

ALTERNATING 'L' and '1'	GO TO FRAME 64 - FLOW TEMPERATURE OVERHEAT LOCKOUT or NO WATER FLOW LOCKOUT
ALTERNATING 'L' and '2'	GO TO FRAME 65 - IGNITION LOCKOUT
ALTERNATING 'L' and '5'	5 RESETS WITHIN 15 MINS - TURN POWER OFF AND ON
ALTERNATING 'L' and '6'	GO TO FRAME 66 - FALSE FLAME LOCKOUT
ALTERNATING 'F' and '0'	BCC (BOILER CHIP CARD) NOT FITTED SEE FRAME 51
ALTERNATING 'F' and '2'	GO TO FRAME 67 - FLAME LOSS
ALTERNATING 'F' and '3'	GO TO FRAME 68 - FAN FAULT
ALTERNATING 'F' and '4'	GO TO FRAME 69 - CONTROL/NO FLOW THERMISTOR FAULT
ALTERNATING 'F' and '5'	GO TO FRAME 70 - RETURN THERMISTOR FAULT
ALTERNATING 'F' and '6'	GO TO FRAME 71 - OUTSIDE SENSOR FAULT
ALTERNATING 'F' and '7'	LOW MAINS VOLTAGE - CONTACT ELECTRICITY PROVIDER
ALTERNATING 'F' and '9'	PCB FAULT - **REPLACE PCB
ALTERNATING 'F' and 'd'	GO TO FRAME 72 - NO WATER FLOW
ALTERNATING 'c' and '2'	GO TO FRAME 73 - BCC FAULT (BOILER CHIP CARD)
ALTERNATING 'c' and '0'	RESET BOILER
NO CH	GO TO FRAME 74
NO HW	GO TO FRAME 76
NO DISPLAY	GO TO FRAME 75

Note that production boiler PCBs are factory pre-set to operate for boiler range and output, but when ordering Primary PCB as a spare, an additional Boiler Chip Card (BCC) MUST also be purchased for your specific boiler range and output.

****If PCB replaced as a spare ensure that the BCC (boiler chip card - small plastic part) is fitted to the PCB otherwise replace PCB.**

RESET PROCEDURE - To reset boiler, turn mode knob to reset position and immediately turn knob back to required setting.

FAULT FINDING

64 ALTERNATING 'L' AND '1' - FLOW TEMPERATURE OVERHEAT LOCKOUT OR NO WATER FLOW LOCKOUT

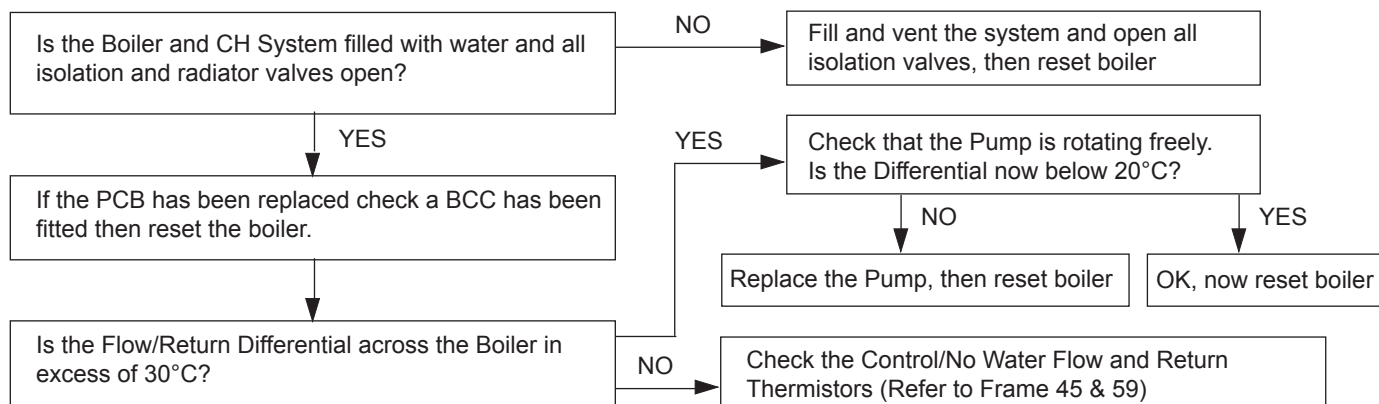

RESET PROCEDURE - To reset boiler, turn mode knob to reset position and immediately turn knob back to required setting.

65 ALTERNATING 'L' AND '2' - IGNITION LOCKOUT

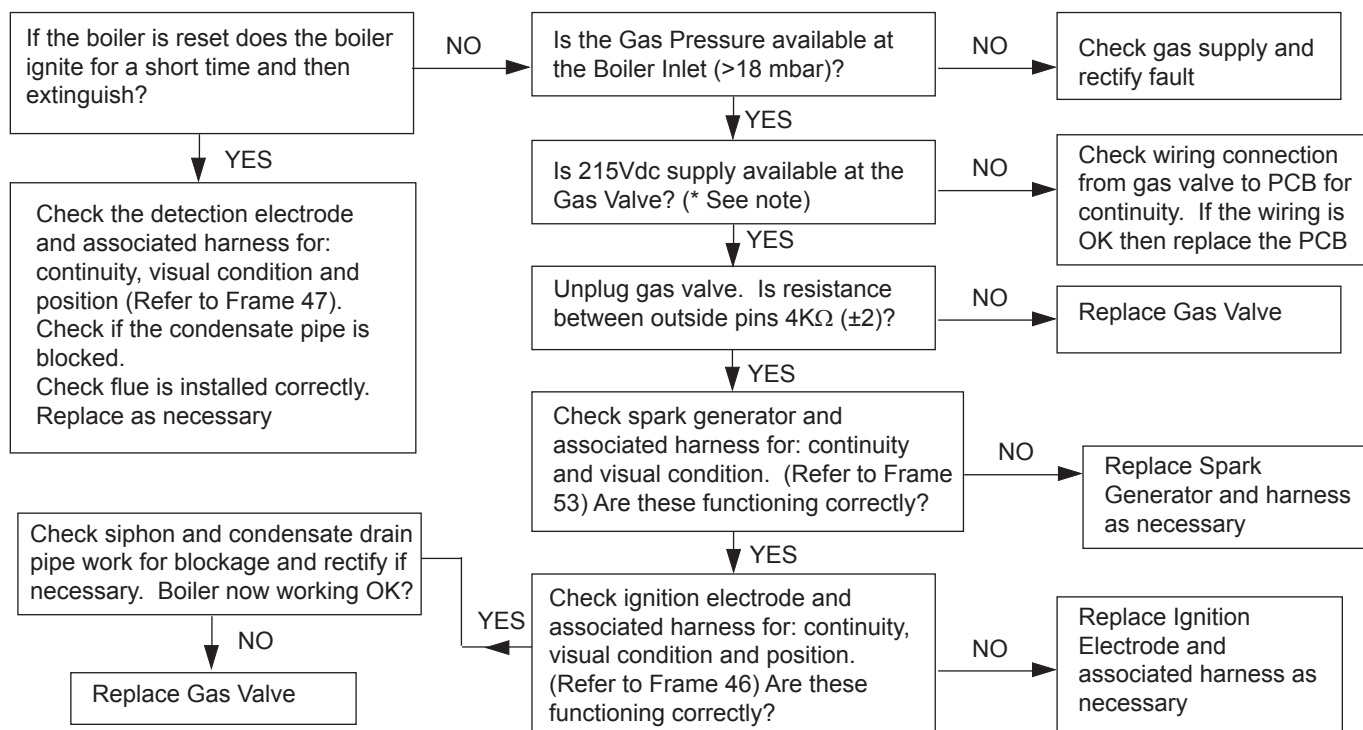

** Note: due to the wave form of the rectified voltage, the reading will vary depending on the type of meter used to measure the value. In general terms a reading greater than 150V indicates that the correct voltage is supplied to the gas valve.*

RESET PROCEDURE - To reset boiler, turn mode knob to reset position and immediately turn knob back to required setting.

66 ALTERNATING 'L' AND '6' - FALSE FLAME LOCKOUT

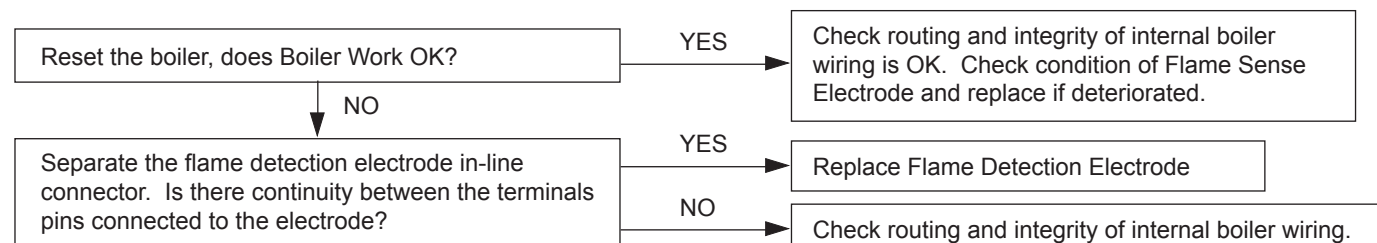

RESET PROCEDURE - To reset boiler, turn mode knob to reset position and immediately turn knob back to required setting.

FAULT FINDING

71 ALTERNATING 'F' AND '6' - OUTSIDE SENSOR FAULT

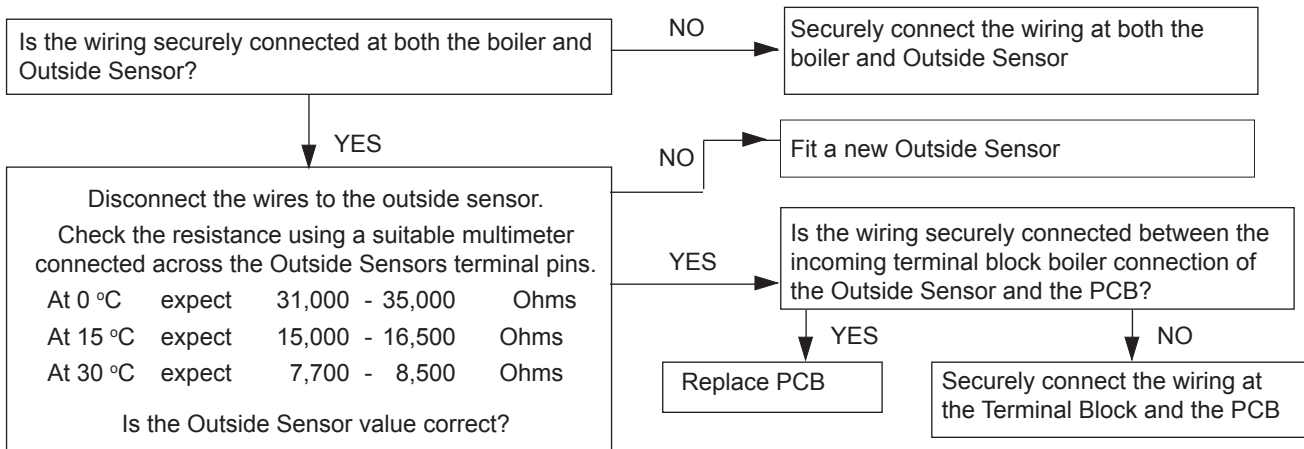

72 ALTERNATING 'F AND 'd' - NO WATER FLOW

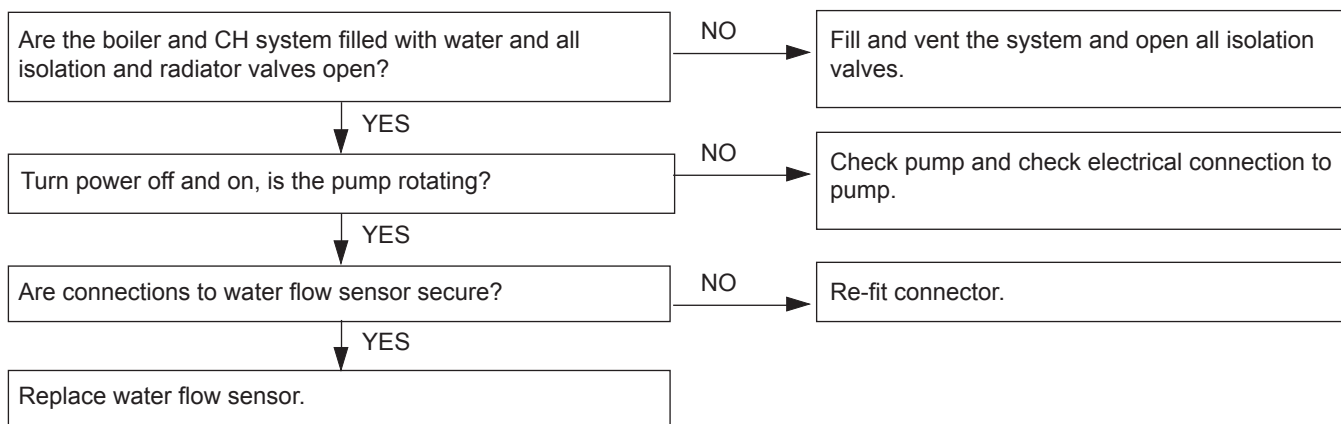

73 ALTERNATING 'c' AND '2' - BCC FAULT (BOILER CHIP CARD)

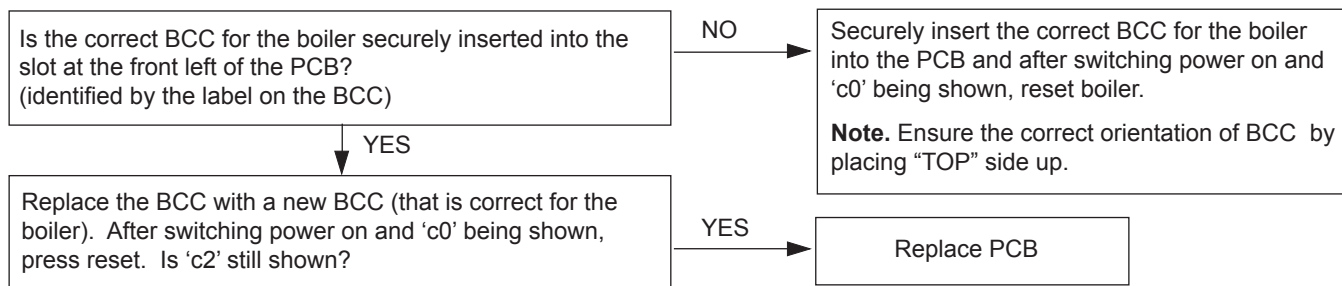

RESET PROCEDURE - To reset boiler, turn mode knob to reset position and immediately turn knob back to required setting.

SPARE PARTS

When replacing any part on this appliance use only spare parts that you can be assured conform to the safety and performance specification that we require. Do not use reconditioned or copy parts that have not been clearly authorised by Ideal. Failure to do so could affect safety or performance of this appliance.

Comprehensive spares parts information and details of approved Ideal Parts Distributors are available on www.idealparts.com

Our Parts team are also available to help with your Ideal Spare Parts enquiries on 01482 498665.

When calling, and to ensure we can provide you with the most accurate parts information, please ensure you have the following to hand;

- Boiler Model
- Appliance GC Number
- Boiler Serial Number

Code Of Practice

For the installation, commissioning and servicing of domestic heating and hot water products

Benchmark places responsibilities on both manufacturers and installers.* The purpose is to ensure that customers** are provided with the correct equipment for their needs, that it is installed, commissioned and serviced in accordance with the manufacturer's instructions by competent persons and that it meets the requirements of the appropriate Building Regulations. Installers are required to carry out work in accordance with the following:

Standards of Work

- Be competent and qualified to undertake the work required.
- Install, commission, service and use products in accordance with the manufacturer's instructions provided.
- Ensure that where there is responsibility for design work, the installation is correctly sized and fit for purpose.
- Meet the requirements of the appropriate Building Regulations. Where this involves notifiable work be a member of a Competent Persons Scheme or confirm that the customer has notified Local Authority Building Control (LABC), prior to work commencing.
- Complete all relevant sections of the Benchmark Checklist/Service Record when carrying out commissioning or servicing of a product or system.
- Ensure that the product or system is left in a safe condition and, whenever possible, in good working order.
- Highlight to the customer any remedial or improvement work identified during the course of commissioning or servicing work.
- Refer to the manufacturer's helpline where assistance is needed.
- Report product faults and concerns to the manufacturer in a timely manner.

Customer Service

- Show the customer any identity card that is relevant to the work being carried out prior to commencement or on request.
- Give a full and clear explanation/demonstration of the product or system and its operation to the customer.
- Hand over the manufacturer's instructions, including the Benchmark Checklist, to the customer on completion of an installation.
- Obtain the customer's signature, on the Benchmark Checklist, to confirm satisfactory demonstration and receipt of manufacturer's instructions.
- Advise the customer that regular product servicing is needed, in line with manufacturers' recommendations, to ensure that safety and efficiency is maintained.
- Respond promptly to calls from a customer following completion of work, providing advice and assistance by phone and, if necessary, visiting the customer.
- Rectify any installation problems at no cost to the customer during the installer's guarantee period.



*The use of the word "installer" is not limited to installation itself and covers those carrying out installation, commissioning and/or servicing of heating and hot water products, or the use of supporting products (such as water treatment or test equipment).

**Customer includes householders, landlords and tenants.

Benchmark Commissioning and Servicing Section

It is a requirement that the boiler is installed and commissioned to the manufacturers instructions and the data fields on the commissioning checklist completed in full.

To instigate the boiler guarantee the boiler needs to be registered with the manufacturer within one month of the installation.

To maintain the boiler guarantee it is essential that the boiler is serviced annually by a Gas Safe registered engineer who has been trained on the boiler installed. The service details should be recorded on the Benchmark Service Interval Record and left with the householder.



www.centralheating.co.uk

© Heating and Hotwater Industry Council (HHIC)

GAS BOILER SYSTEM COMMISSIONING CHECKLIST

This Commissioning Checklist is to be completed in full by the competent person who commissioned the boiler as a means of demonstrating compliance with the appropriate Building Regulations and then handed to the customer to keep for future reference.

Failure to install and commission according to the manufacturer's instructions and complete this Benchmark Commissioning Checklist will invalidate the warranty. This does not affect the customer's statutory rights.

Customer name:				Telephone number:			
Address:							
Boiler make and model:							
Boiler serial number:							
Commissioned by (PRINT NAME):				Gas Safe register number:			
Company name:				Telephone number:			
Company address:							
				Commissioning date:			
To be completed by the customer on receipt of a Building Regulations Compliance Certificate*							
Building Regulations Notification Number (if applicable):							
CONTROLS (tick the appropriate boxes)							
Time and temperature control to heating	Room thermostat and programmer/timer	<input type="checkbox"/>	Programmable room thermostat	<input type="checkbox"/>			
	Load/weather compensation	<input type="checkbox"/>	Optimum start control	<input type="checkbox"/>			
Time and temperature control to hot water	Cylinder thermostat and programmer/timer	<input type="checkbox"/>	Combination Boiler	<input type="checkbox"/>			
Heating zone valves	Fitted	<input type="checkbox"/>	Not required	<input type="checkbox"/>			
Hot water zone valves	Fitted	<input type="checkbox"/>	Not required	<input type="checkbox"/>			
Thermostatic radiator valves	Fitted	<input type="checkbox"/>	Not required	<input type="checkbox"/>			
Automatic bypass to system	Fitted	<input type="checkbox"/>	Not required	<input type="checkbox"/>			
Boiler interlock		<input type="checkbox"/>	Provided	<input type="checkbox"/>			
ALL SYSTEMS							
The system has been flushed and cleaned in accordance with BS7593 and boiler manufacturer's instructions				Yes	<input type="checkbox"/>		
What system cleaner was used?							
What inhibitor was used?				Quantity	litres		
Has a primary water system filter been installed?				Yes	<input type="checkbox"/>	No	<input type="checkbox"/>
CENTRAL HEATING MODE measure and record:							
Gas rate	m ³ /hr	<input type="checkbox"/>	OR	ft ³ /hr	<input type="checkbox"/>		
Burner operating pressure (if applicable)	mbar	<input type="checkbox"/>	OR Gas inlet pressure	mbar	<input type="checkbox"/>		
Central heating flow temperature				°C	<input type="checkbox"/>		
Central heating return temperature				°C	<input type="checkbox"/>		
COMBINATION BOILERS ONLY							
Is the installation in a hard water area (above 200ppm)?				Yes	<input type="checkbox"/>	No	<input type="checkbox"/>
If yes, and if required by the manufacturer, has a water scale reducer been fitted?				Yes	<input type="checkbox"/>	No	<input type="checkbox"/>
What type of scale reducer has been fitted?							
DOMESTIC HOT WATER MODE Measure and Record:							
Gas rate	m ³ /hr	<input type="checkbox"/>	OR	ft ³ /hr	<input type="checkbox"/>		
Burner operating pressure (at maximum rate)	mbar	<input type="checkbox"/>	OR Gas inlet pressure at maximum rate	mbar	<input type="checkbox"/>		
Cold water inlet temperature				°C	<input type="checkbox"/>		
Hot water has been checked at all outlets		Yes	<input type="checkbox"/>	Temperature	°C	<input type="checkbox"/>	
Water flow rate				l/min	<input type="checkbox"/>		
CONDENSING BOILERS ONLY							
The condensate drain has been installed in accordance with the manufacturer's instructions and/or BS5546/BS6798				Yes	<input type="checkbox"/>		
ALL INSTALLATIONS							
Record the following:	At max. rate:	CO	ppm	AND	CO/CO ₂	Ratio	<input type="checkbox"/>
	At min. rate: (where possible)	CO	ppm	AND	CO/CO ₂	Ratio	<input type="checkbox"/>
The heating and hot water system complies with the appropriate Building Regulations				Yes	<input type="checkbox"/>		
The boiler and associated products have been installed and commissioned in accordance with the manufacturer's instructions				Yes	<input type="checkbox"/>		
The operation of the boiler and system controls have been demonstrated to and understood by the customer				Yes	<input type="checkbox"/>		
The manufacturer's literature, including Benchmark Checklist and Service Record, has been explained and left with the customer				Yes	<input type="checkbox"/>		
Commissioning Engineer's Signature							
Customer's Signature							
(To confirm satisfactory demonstration and receipt of manufacturer's literature)							

* All installations in England and Wales must be notified to Local Authority Building Control (LABC) either directly or through a Competent Persons Scheme. A Building Regulations Compliance Certificate will then be issued to the customer.



SERVICE RECORD

It is recommended that your heating system is serviced regularly and that the appropriate Service Interval Record is completed.

Service Provider

Before completing the appropriate Service Record below, please ensure you have carried out the service as described in the manufacturer's instructions. Always use the manufacturer's specified spare part when replacing controls.

SERVICE 01					Date:
Engineer name:					
Company name:					
Telephone No:					
Gas safe register No:					
Record:	At max. rate:	CO	ppm	AND	CO ₂ %
	At min. rate: (Where Possible)	CO	ppm	AND	CO ₂ %
Comments:					
Signature					

SERVICE 02					Date:
Engineer name:					
Company name:					
Telephone No:					
Gas safe register No:					
Record:	At max. rate:	CO	ppm	AND	CO ₂ %
	At min. rate: (Where Possible)	CO	ppm	AND	CO ₂ %
Comments:					
Signature					

SERVICE 03					Date:
Engineer name:					
Company name:					
Telephone No:					
Gas safe register No:					
Record:	At max. rate:	CO	ppm	AND	CO ₂ %
	At min. rate: (Where Possible)	CO	ppm	AND	CO ₂ %
Comments:					
Signature					

SERVICE 04					Date:
Engineer name:					
Company name:					
Telephone No:					
Gas safe register No:					
Record:	At max. rate:	CO	ppm	AND	CO ₂ %
	At min. rate: (Where Possible)	CO	ppm	AND	CO ₂ %
Comments:					
Signature					

SERVICE 05					Date:
Engineer name:					
Company name:					
Telephone No:					
Gas safe register No:					
Record:	At max. rate:	CO	ppm	AND	CO ₂ %
	At min. rate: (Where Possible)	CO	ppm	AND	CO ₂ %
Comments:					
Signature					

SERVICE 06					Date:
Engineer name:					
Company name:					
Telephone No:					
Gas safe register No:					
Record:	At max. rate:	CO	ppm	AND	CO ₂ %
	At min. rate: (Where Possible)	CO	ppm	AND	CO ₂ %
Comments:					
Signature					

SERVICE 07					Date:
Engineer name:					
Company name:					
Telephone No:					
Gas safe register No:					
Record:	At max. rate:	CO	ppm	AND	CO ₂ %
	At min. rate: (Where Possible)	CO	ppm	AND	CO ₂ %
Comments:					
Signature					

SERVICE 08					Date:
Engineer name:					
Company name:					
Telephone No:					
Gas safe register No:					
Record:	At max. rate:	CO	ppm	AND	CO ₂ %
	At min. rate: (Where Possible)	CO	ppm	AND	CO ₂ %
Comments:					
Signature					

SERVICE 09					Date:
Engineer name:					
Company name:					
Telephone No:					
Gas safe register No:					
Record:	At max. rate:	CO	ppm	AND	CO ₂ %
	At min. rate: (Where Possible)	CO	ppm	AND	CO ₂ %
Comments:					
Signature					

SERVICE 10					Date:
Engineer name:					
Company name:					
Telephone No:					
Gas safe register No:					
Record:	At max. rate:	CO	ppm	AND	CO ₂ %
	At min. rate: (Where Possible)	CO	ppm	AND	CO ₂ %
Comments:					
Signature					

* All installations in England and Wales must be notified to Local Authority Building Control (LABC) either directly or through a Competent Persons Scheme. A Building Regulations Compliance Certificate will then be issued to the customer.

FLOWCHART FOR CO LEVEL AND COMBUSTION RATIO CHECK ON COMMISSIONING A CONDENSING BOILER

Important Preliminary Information on Checks

The air gas ratio valve is factory-set and must not be adjusted DURING COMMISSIONING.

If the boiler requires conversion to operate with a different gas family (e.g. conversion from natural gas to LPG) separate guidance is provided with the conversion kit supplied and this must be followed.

PRIOR TO CO LEVEL AND COMBUSTION RATIO CHECK

The installation instructions must have been followed, gas type verified and gas supply pressure / gas rate checked as required prior to commissioning.

As part of the installation process, ESPECIALLY WHERE A FLUE HAS BEEN FITTED BY PERSONS OTHER THAN THE BOILER INSTALLER, visually check the integrity of the whole flue system to confirm that all components are correctly assembled, fixed and supported. Check that maximum flue lengths have not been exceeded and all guidance has been followed (e.g. Gas Safe Register Technical Bulletin (TB) 008 where chimney/flues are in voids).

The ECGA should be of the correct type, as specified by BS 7967.

Prior to its use, the ECGA should have been maintained and calibrated as specified by the manufacturer. The installer must have the relevant competence for use of the analyser.

Check and zero the analyser IN FRESH AIR in accordance with the analyser manufacturer's instructions.

KEY:

CO = carbon monoxide

CO₂ = carbon dioxide

O₂ = oxygen

Combustion Ratio = The CO reading measured in ppm divided by the CO₂ reading first converted to ppm

ppm = parts per million

GS(I&U)R = Gas Safety (Installation and Use) Regulations

*Setting to Minimum Rate:

1. Turn the CH temperature control knob into the 10 O'clock position.
2. Create a heat demand by ensuring that the system controls are requesting heat and the boiler Mode Knob is in the On Position.
3. Within an overall time of 3 seconds, turn the CH temperature control knob fully clockwise, back to 10 O'clock and then fully clockwise again.
4. "S" will be shown on the display and the boiler output will be reduced to minimum.
5. The boiler will remain at minimum rate for 5 minutes before reverting to normal operation.

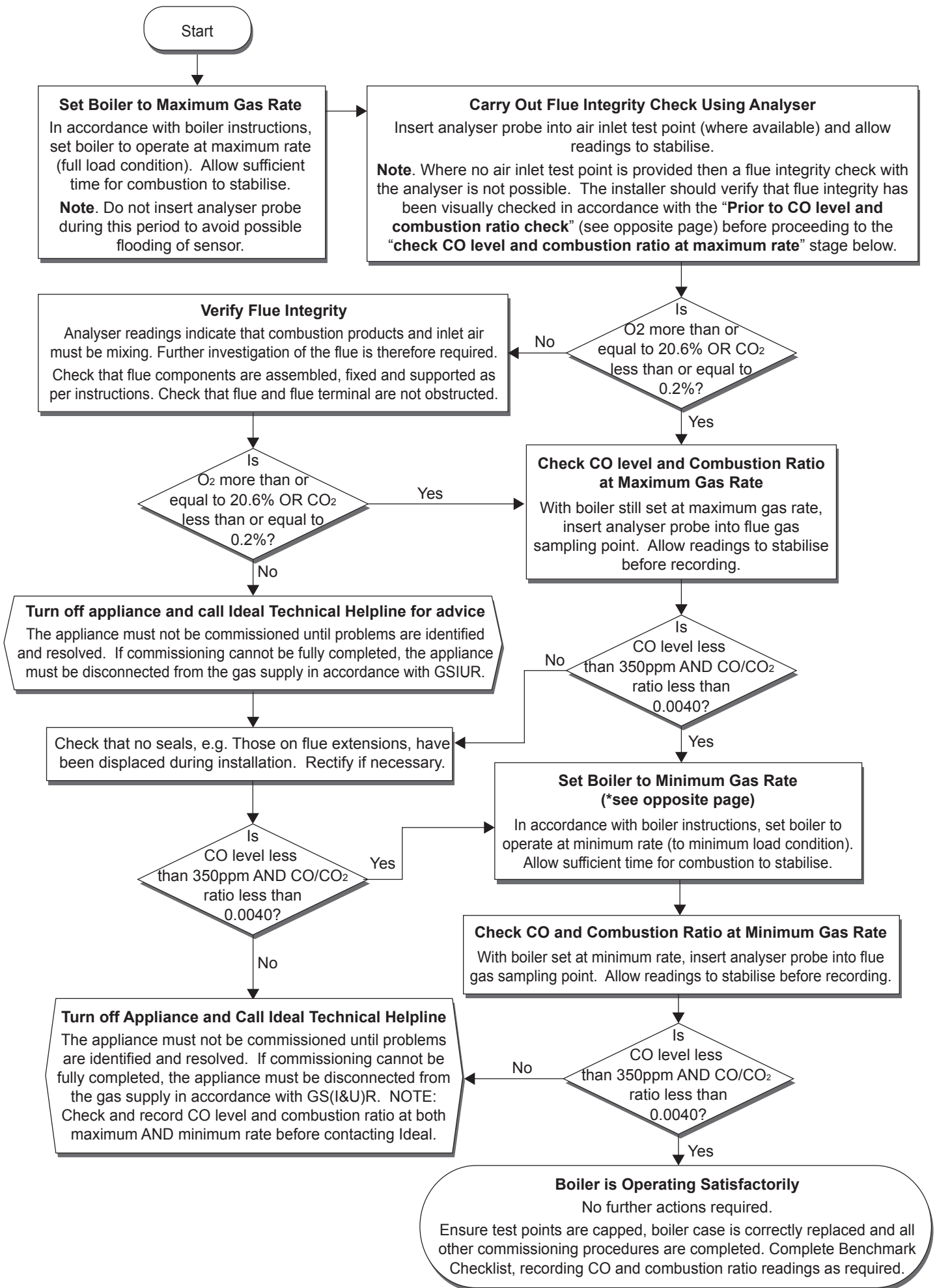

For additional fault finding advice please visit Ideal's website

www.idealboilers.com

Technical Training

The Ideal Technical Training Centre offers a series of first class training courses for domestic, commercial and industrial heating installers, engineers and system specifiers. For details of courses please ring:..... +44 (0)1482 498 432



The code of practice for the installation, commissioning & servicing of central heating systems



FM 59915

Manufactured under an ISO 9001 registered quality management system

Ideal Boilers Ltd., P.O. Box 103, National Ave, Kingston upon Hull, HU5 4JN. Telephone: +44 (0)1482 492 251 Fax: +44 (0)1482 448 858. Registration No. London 322 137.

Ideal Stelrad Group pursues a policy of continuing improvement in the design and performance of its products. The right is therefore reserved to vary specification without notice.



Ideal Stelrad Group

Ideal Technical Helpline: +44 (0)1482 498 663

www.idealboilers.com