



**+ EVOJET CONDENSING
PRESSURE JET BOILERS.
150 - 1450kW**

 @idealboilers  Ideal Boilers

IDEALCOMMERCIALBOILERS.COM



Ideal Commercial Boilers is one of the most respected names in the UK commercial and domestic heating industry, operating from its Hull manufacturing plant and offices since 1906. Ideal Commercial Boilers is one of the few true British Manufacturers left in the heating industry.

With over 100 years of manufacturing experience, you can be confident to know that our heating products are perfectly designed to meet your individual building requirements. Our products are easy to specify, simple to install, maintain and most importantly are reliable.

THE COMMERCIAL BOILERS TEAM

As industry leaders, Ideal Commercial Boilers is committed to ensuring that all products are engineered to the highest standards. From dedicated one-to-one support throughout the design, planning and after sales service stages, you can be confident to know that we can provide you with the Ideal Commercial Boilers and hot water solution.

COMMERCIAL PRODUCTS, SALES SUPPORT & CONTACT NUMBERS.

SALES - ORDERS, AVAILABILITY, LITERATURE AND PRICING ON COMMERCIAL BOILERS

T: 0844 5436060
F: 0844 5436181
commercial.boilers@idealboilers.com
www.idealcommercialboilers.com

Technical & Customer Services

T: 01482 498376
F: 01482 498621
commercial.services@idealboilers.com

SPARES, SALES SUPPORT & CONTACT NUMBERS.

Spares - Orders, availability and pricing on Spares

T: 01482 498665
F: 01482 498489

CONTENTS.

2	Introduction
4-5	Features & Benefits
6-7	Performance / General Data
8-9	Boiler Assembly
10	Place of Installation
11	Temperature Control & Ventilation
12-13	System Connections
14	System Applications
15	System Requirements
16-17	Commercial Range Overview

TRAINING & SUPPORT

18	Ideal Commercial Training
19	Ideal Service & Support



FLOOR
STANDING



NOX CLASS
5



PRESSURE
JET



ErP
COMPLIANT



DUAL FUEL

EVOJET 150 - 1450 kW.

CONDENSING PRESSURE JET

The Evojet condensing range of pressure jet boilers are available in 10 models with outputs from 150-1450kW. Floor standing boilers for applications in either single or multiple configurations.

FEATURES AND BENEFITS

- Up to 109.3% part load efficiency
- Dedicated low temp return
- Stainless steel heat exchanger
- Natural gas, LPG, oil and dual fuel models
- Triple flue pass for high operating efficiencies
- Natural gas/LPG burner options - modulating or high / low operation
- Modulation via 0-10 volt BMS, or RWF controller

DIMENSIONS AND CLEARANCES.

BOILER	DIM A	DIM B	DIM C
150	740	1455	1315
210	740	1455	1315
270	850	1630	1450
350	850	1830	1450
450	900	2035	1630
600	900	2235	1630
800	1060	2560	1910
1000	1060	2810	1910
1250	1180	3010	2030
1450	1225	3080	2180

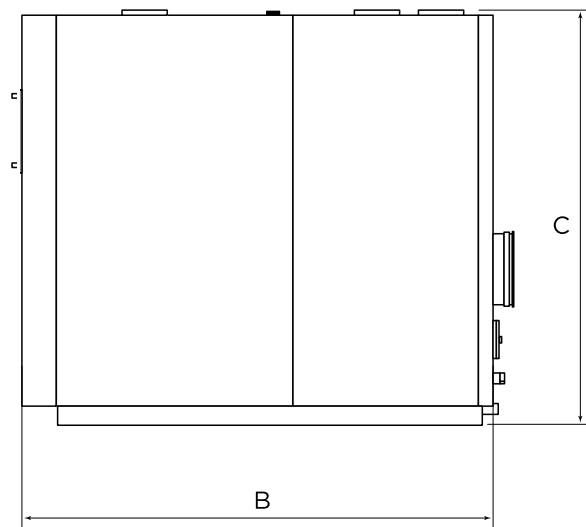
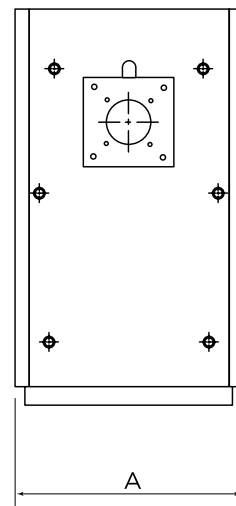

The following minimum clearances must be maintained for operation and servicing:

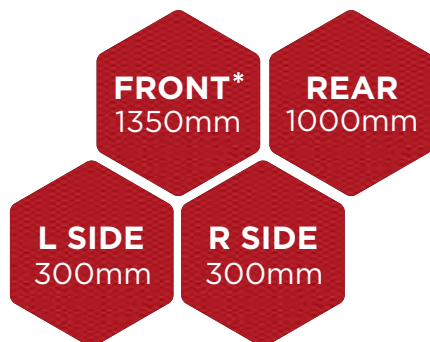

• Minimum recommended is the burner length

All dimensions in mm



PERFORMANCE DATA.

EVOJET 150 - 1450 kW (GAS)

MODEL			150	210	270	350	450	600	800	1000	1250	1450
Output Power (80/60)	Max	kW	146.6	205.2	264.3	343.7	441.9	589.2	785.6	982	1227.5	1423.9
	Min	kW	108.2	147.1	207.8	264.2	342.2	439.7	586	781	976	1219.7
Output Power (50/30)	Max	kW	160.5	224.7	288.9	374.5	481.5	642	856	1070	1337.5	1551.5
Efficiency Pn (80/60)	Max	%	97.7	97.7	97.9	98.2	98.2	98.2	98.2	98.2	98.2	98.2
	Min	%	97.5	97.7	98.2	98.3	97.5	97.5	97.5	97.5	97.5	97.5
Efficiency Pn (50/30)	Max	%	107	107	107	107	107	107	107	107	107	107
Efficiency Part Load		%	108.5	109.3	109.2	108.7	108.7	108.7	108.7	108.7	108.7	108.7
Losses from stack for sensible heat (Qmax)		%	1.7	1.7	1.5	1.5	1.9	1.9	1.9	1.9	1.9	1.9
Losses from casing with burner on		%	0.3	0.3	0.5	1.0	0.6	0.6	0.6	0.6	0.6	0.6

For Btu's, multiply gross heat input (kW) by 3412 (Btu)

GENERAL DATA.

EVOJET 150 - 1450 kW (GAS)

(*) Depends on return temperature (30-60°C)
 (**) At Pn max and output T = 80°C, return T = 60°C and CO₂ = 10.3%

MODEL		150	210	270	350	450	600	800	1000	1250	1450	
Fuel		GAS (Natural Gas & LPG compatible)										
Constant pressure drop	%	<1										
Flue gas temperature (ΔT)	°C	< 45+75 (*)										
Flue gas mass flow rate (Q max) (**)	kg/sec	0.07	0.09	0.12	0.15	0.20	0.26	0.33	0.43	0.54	0.63	
Furnace pressure	mbar	2.0	2.7	3.2	4.6	5.0	5.5	5.7	6.3	6.8	7.4	
Furnace volume	dm ³	172	172	241	279	442	496	753	845	1037	1249	
Total volume of flue gas side	dm ³	272	292	413	482	737	860	129	1454	1763	2097	
Heat exchanger surface area	m ²	8.2	10.4	13.0	16.3	21.8	28.8	39.6	46.5	56.2	62.28	
Volumetric heat load (Q max)	kW/m ³	872	1221	1120	1254	1018	1210	1062	1183	1205	1161	
Specific heat load	kW/m ²	18	19.9	20.4	20.9	20.1	20.3	18.5	21.0	21.7	22.6	
Maximum condensate production	l/h	18.4	27.4	31.9	40.9	52.2	73.8	88.0	111.4	132.7	159.5	
Maximum working pressure	bar	6										
Maximum admissible temperature	°C	110										
Maximum working temperature	°C	95										
Pressure drop ΔT 10°C	mbar	43.2	36.0	54.0	46.4	33.8	30.2	128.7	121.5	100.4	150.1	
Pressure drop ΔT 20°C	mbar	11.3	10.2	16.3	13.4	9.0	8.5	28.7	30.6	28.4	36.3	
Water capacity	l	323	360	495	555	743	770	1320	1395	1825	1900	
Weight of boiler	kg	510	530	677	753	1095	1250	1870	2085	2515	3050	
Weight of panelling	kg	50	50	60	70	90	120	140	160	215	230	

PERFORMANCE DATA.

EVOJET 150 - 1450 kW (OIL)

MODEL			210	270	350	450	600	800	1000	1250	1450
Output Power (80/60)	Max	kW	203.7	263.8	343.7	441.9	589.2	785.6	982	1227.5	1423.9
	Min	kW	147.1	207.8	264.2	342.2	439.7	586	781	976	1219.7
Efficiency Pn (80/60)	Max	%	97.0	97.7	98.2	98.2	98.2	98.2	98.2	98.2	98.2
	Min	%	97.4	98.5	97.5	97.5	97.5	97.5	97.5	97.5	97.5
Losses from stack for sensible heat (Qmax)		%	1.7	1.5	1.5	1.9	1.9	1.9	1.9	1.9	1.9
Losses from casing with burner on		%	0.3	0.5	1.0	0.6	0.6	0.6	0.6	0.6	0.6

GENERAL DATA.

EVOJET 150 - 1450 kW (OIL)

(*) At Pn max and output T = 80°C, return T = 60°C and CO₂ = 10.3%

MODEL		210	270	350	450	600	800	1000	1250	1450	
Fuel		Low Sulphur Oil									
Constant pressure drop	%	<1									
Flue gas temperature (ΔT)	°C	75.0									
Flue gas mass flow rate (Q max) (*)	kg/sec	0.09	0.12	0.15	0.20	0.26	0.33	0.43	0.54	0.63	
Furnace pressure	mbar	2.7	3.2	4.6	5.0	5.5	5.7	6.3	6.8	7.4	
Furnace volume	dm ³	172	241	279	442	496	753	845	1037	1249	
Total volume of flue gas side	dm ³	292	413	482	737	860	129	1454	1763	2097	
Heat exchanger surface area	m ²	10.4	13.0	16.3	21.8	28.8	39.6	46.5	56.2	62.28	
Volumetric heat load (Q max)	kW/m ³	1221	1120	1254	1018	1210	1062	1183	1205	1161	
Specific heat load	kW/m ²	19.9	20.4	20.9	20.1	20.3	18.5	21.0	21.7	22.6	
Maximum working pressure	bar	6									
Maximum admissible temperature	°C	110									
Maximum working temperature	°C	95									
Pressure drop ΔT 10°C	mbar	36.0	54.0	46.4	33.8	30.2	128.7	121.5	100.4	150.1	
Pressure drop ΔT 20°C	mbar	10.2	16.3	13.4	9.0	8.5	28.7	30.6	28.4	36.3	
Water capacity	l	360	495	555	743	770	1320	1395	1825	1900	
Weight of boiler	kg	530	677	753	1095	1250	1870	2085	2515	3050	
Weight of panelling	kg	50	60	70	90	120	140	160	215	230	

BOILER ASSEMBLY.

EVOJET 150 - 1450 kW

KEY FEATURES

- Twin return water connections
- High water content
- Pressurised combustion chamber for smooth burner operation
- Stainless steel turbulator for maximum heat transfer and increased efficiency
- Double insulated boiler housing
- Front door inspection without removing burner
- Complete with control panel
- Triple flue pass for high operating efficiencies

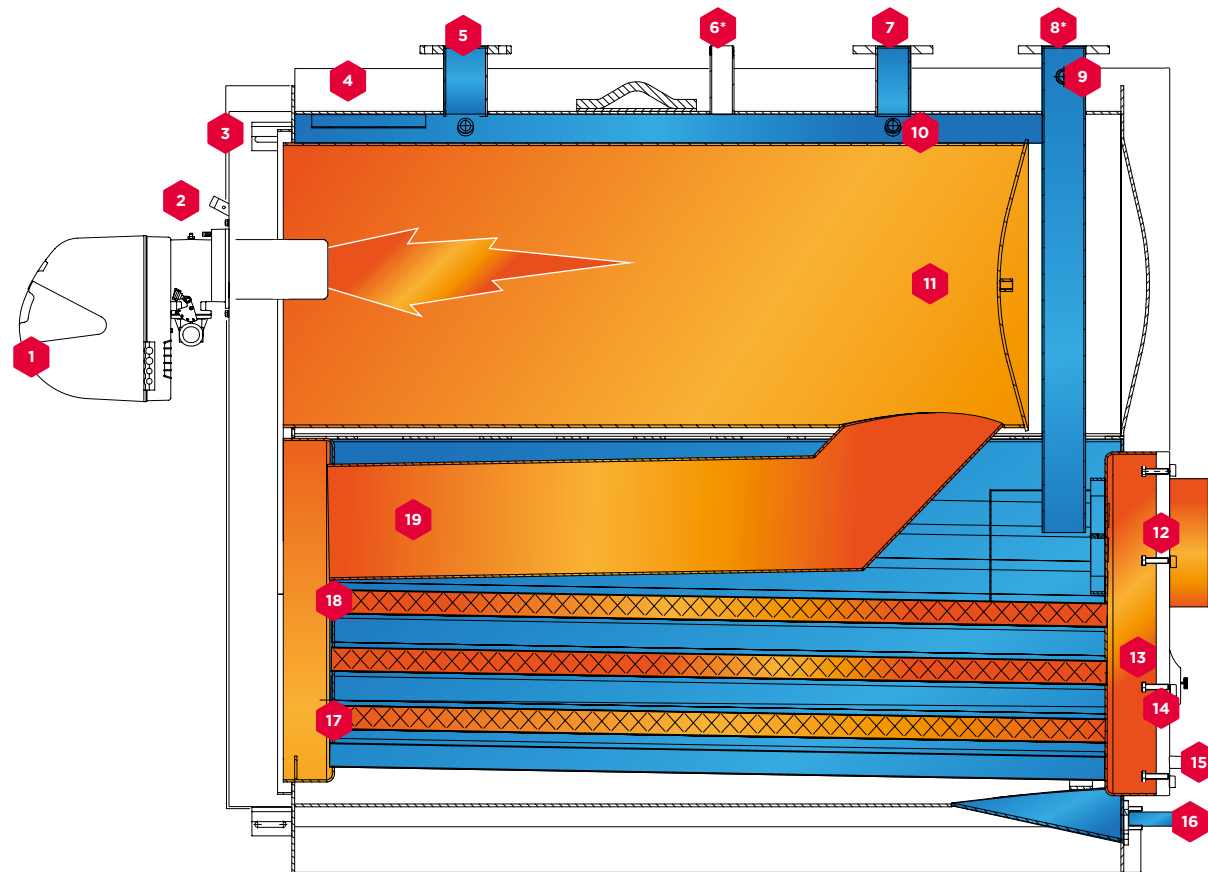

KEY

- | | | |
|--|---------------------------------------|----------------------|
| 1. Burner | 7 Heating return (high temperature) | 12. Flue connection |
| 2. Flame inspection window with pressure measurement point | 8. Heating return (low temperature)** | 13. Flue gas box |
| 3. Door | 9. Blind plug | 14. Inspection door |
| 4. Panelling | 10. Instrument bulb/probe socket | 15. Condensate drain |
| 5. Outlet | 11. Combustion chamber | 16. Boiler drain |
| 6. Safety device fitting* | | 17. Turbulators |
| | | 18. Third flue pass |
| | | 19. Second flue pass |

*For 1450 models the safety device fitting is flanged.

**For 1450 models the low temperature heating return is located at the rear of the boiler. (See page 11 1450 diagram)

BOILER ASSEMBLY.

EVOJET 150 - 1450 kW

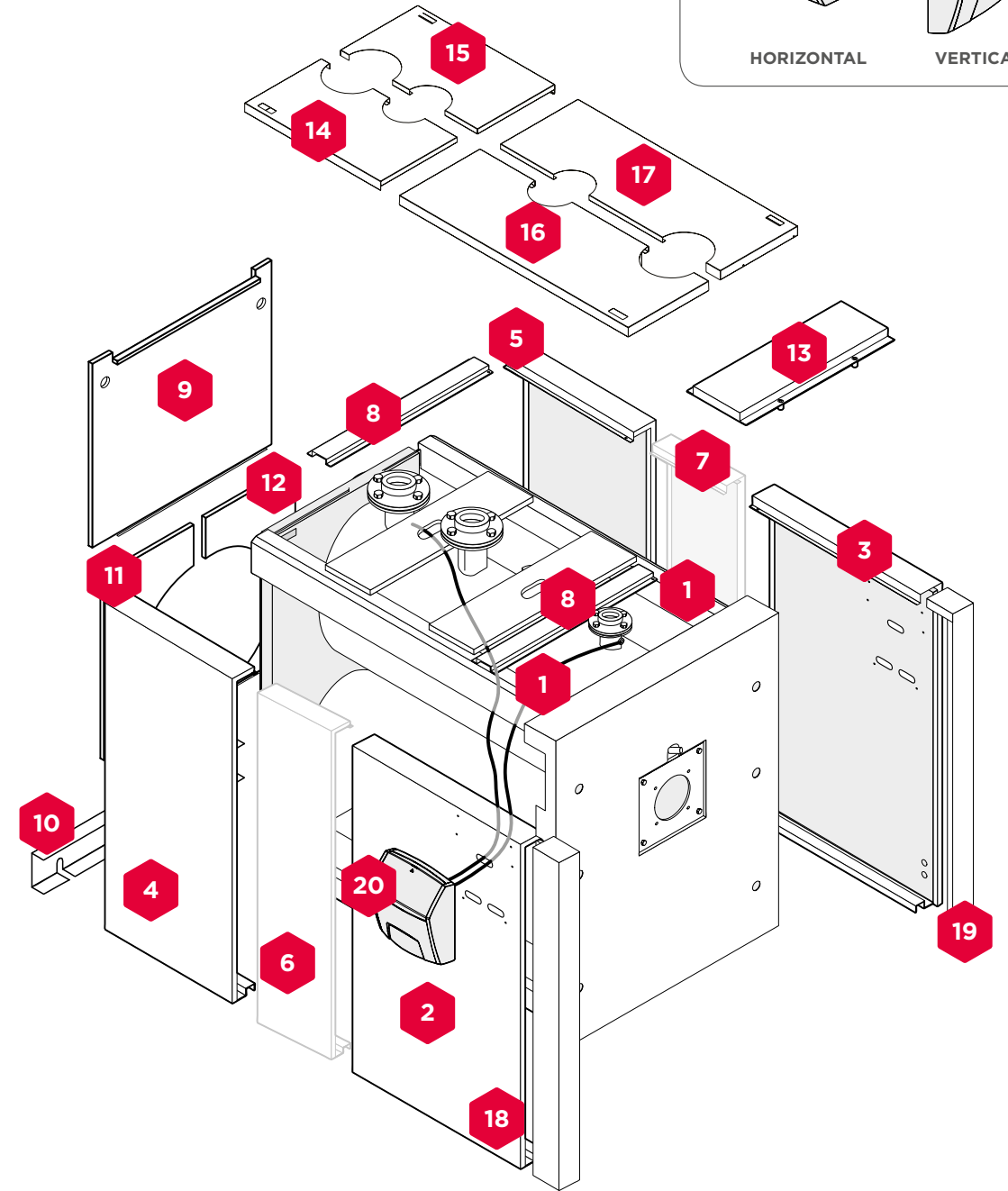
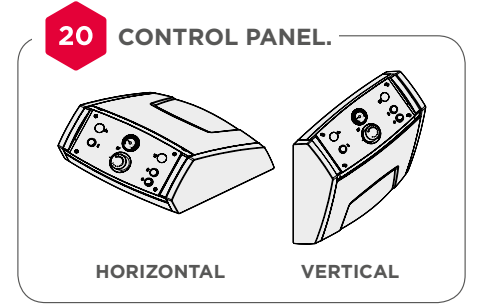

KEY

- | | | |
|------------------------|--------------------------|-----------------------|
| 1 - Boiler frame | 8 - Top cross beams | 15 - Top panel |
| 2 - Side Panel | 9 - Top rear panel | 16 - Top panel |
| 3 - Side Panel | 10 - Bottom rear bracket | 17 - Top panel |
| 4 - Rear Panel | 11 - Bottom rear panel | 18 - Front trim panel |
| 5 - Rear Panel | 12 - Bottom rear panel | 19 - Front trim panel |
| 6 - Central side panel | 13 - Front top panel | 20 - Control panel |
| 7 - Central side panel | 14 - Top panel | |

PLACE OF INSTALLATION.

EVOJET steel boilers must be installed in a dedicated boiler room, with adequately sized vents, in compliance with BS6644.

If at all possible, the boiler should be installed on a raised base to stop the burner fan sucking up dust and to facilitate installation of a condensate drain system.

The boiler condensate drain must be located above the height of the lid of the system's condensate neutraliser if fitted.

The gas supply pipe must be installed in such away that the boiler's panelling can be removed and the front door opened without having to remove the burner.

CLEARANCES.

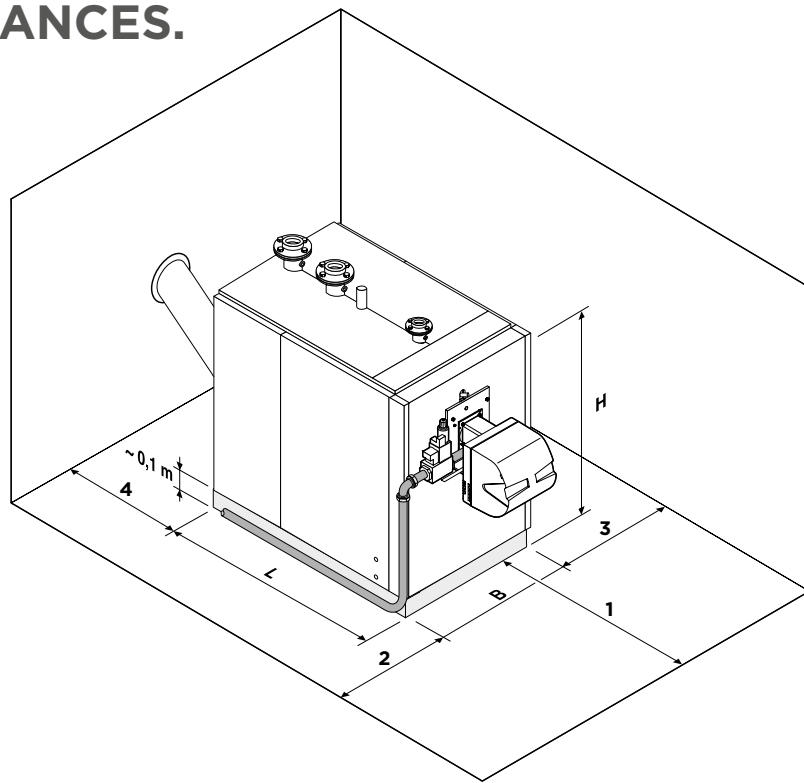

DESCRIPTION	BOILER MODEL									
	150	210	270	350	450	600	800	1000	1250	1450
B - Width (mm)	750	750	850	850	900	900	1000	1000	1200	1250
L - Depth (mm)	1350	1350	1620	1820	1930	2140	2400	2700	2920	3100
H - Overall height (boiler + base) (mm)	1420	1420	1540	1540	1700	1700	2010	2010	2130	2280
1 - Front clearance (mm) *	1350	1350	1620	1820	1930	2140	2400	2700	2920	3100
2 - Left clearance min (mm)**	300	300	300	300	300	300	300	300	300	600
3 - Right clearance min (mm)**	300	300	300	300	300	300	300	300	300	600
4 - Rear clearance (mm)	1000	1000	1000	1000	1000	1000	1000	1000	1000	1000

* Front clearance can be reduced dependent on the burner used and consideration for turbulator removal

**For further guidance on clearances refer to the installation manual

EVOJET TEMPERATURE CONTROL.

The standard Evojet boiler controller is suitable for controlling the temperature using a single jet burner.

Control panels can be installed either on the top of the boiler or on one of its side panels in either vertical or horizontal orientations.

CONTROL PANEL FEATURES INCLUDE:

- Robust ABS housing
- Thermometer
- Overheat lockout / reset button
- Burner lockout indicator
- Compatible with modulating burner controls utilising 0-10 volt BMS
- Compatible with modulating burner controls utilising RWF option



VENTILATION.

OPEN FLUED APPLICATION

Safe, efficient, and trouble-free operation of conventionally flued gas boilers is vitally dependent on the provision of an adequate supply of fresh air to the room in which the appliance is installed.

Ventilation by grilles communicating directly with the outside air is required at both high and low levels. The minimum free areas of these grilles must be in accordance with BS6644 or IGE UP10. The use of an extractor fan in the same room as the boiler (or in an adjacent room in communication) can, in certain conditions, adversely affect the safe operation of the boiler. Where such a fan is already fitted, or if an extractor fan is likely to be installed at a later date, then the advice of the gas supplier should be obtained.

BS 6644 - Inputs greater than 70kW (nett)

TOTAL GROSS INPUT RATING OF BOILERS	POSITION OF AIR VENTS	AIR VENT AREAS* (CM2) (AIR DIRECT FROM OUTSIDE)	
		Boiler room	Enclosure
70kW to 1.8MW	High level	Boiler room	Enclosure
		2	5
70kW to 1.8MW	Low level	Boiler room	Enclosure
		4	10

*Required area is cm2 per kW of nett input. Note: where a boiler installation is to operate in summer months (e.g. DHW) additional ventilation requirements are stated. If operating for more than 50% of time refer to BS 6644.

SYSTEM CONNECTIONS.

EVOJET boilers are designed and made for use in central heating installations, but can also be used for domestic hot water production if connected to suitable sub-systems. Water fittings are as specified in the following table:

DESCRIPTION	BOILER MODEL										
	150	210	270	350	450	600	800	1000	1250	1450	
1 - Heating flow (*)	65	65	65	80	100	100	125	125	150	150	DN
2 - Heating return 1 (Low Temperature) (*)	65	65	65	80	100	100	125	125	150	150	DN
3 - Heating return 2 (High Temperature) (*)	50	50	50	65	80	80	80	80	100	100	DN
4 - Safety device fitting	1" 1/4	1" 1/4	1" 1/4	1" 1/4	1" 1/2	1" 1/2	80	80	80	80	Ø"- DN
5 - Boiler drain fitting	1"	1"	1"	1"	1"	1"	1" 1/4	1" 1/4	1" 1/4	1" 1/4	Ø"
6 - Condensate drain fitting	1"	1"	1"	1"	1" 1/4	1" 1/4	1" 1/4	1" 1/4	1" 1/4	1" 1/4	Ø"- DN
7 - Flue gas exhaust fitting	200	200	250	250	300	300	350	350	400	450	Ø" mm
8 - Instrument bulb/probe sockets	3 x 1/2"	3 x 1/2"	3 x 1/2"	3 x 1/2"	3 x 1/2"	3 x 1/2"	3 x 1/2"	3 x 1/2"	3 x 1/2"	3 x 1/2"	n° x Ø"
A - Distance from burner head to heating flow outlet	300	300	300	315	311	311	410	410	430	440	mm
B - Distance from heating flow outlet to return 1	885	885	1050	1235	1400	1600	1800	2050	2200	2585	mm
C - Distance between heating returns 1 & 2	200	200	300	250	250	300	350	350	350	735	mm
D - Distance between heating return 2 and safety device fitting	285	285	300	450	600	700	750	850	850	850	mm
E - Distance between heating flow outlet and safety device fitting	400	400	450	535	550	600	700	855	1000	1000	mm
F - Distance between heating return 1 and flue gas outlet	200	200	225	225	270	270	325	325	345	560	mm
G - Height of condensate drain	160	160	165	165	215	215	195	195	225	235	mm
H - Height of boiler flanges	1340	1340	1450	1450	1630	1630	1910	1910	2030	2180	mm
I - Height of flue gas outlet	405	405	545	545	645	645	680	680	720	805	mm
L - Height of boiler drain fitting	60	60	55	55	75	75	95	95	105	85	mm
M - Boiler centreline	345	345	375	375	395	395	475	475	535	565	mm
N - Distance from burner head to door	110	110	120	120	125	125	125	125	140	150	mm
O - Distance from Boiler drain fitting	132	132	137	137	125	125	175	175	180	180	mm

(*) All flanged connections are PN6 according to EN 1092-1.

EVOJET 150 - 1250 models:

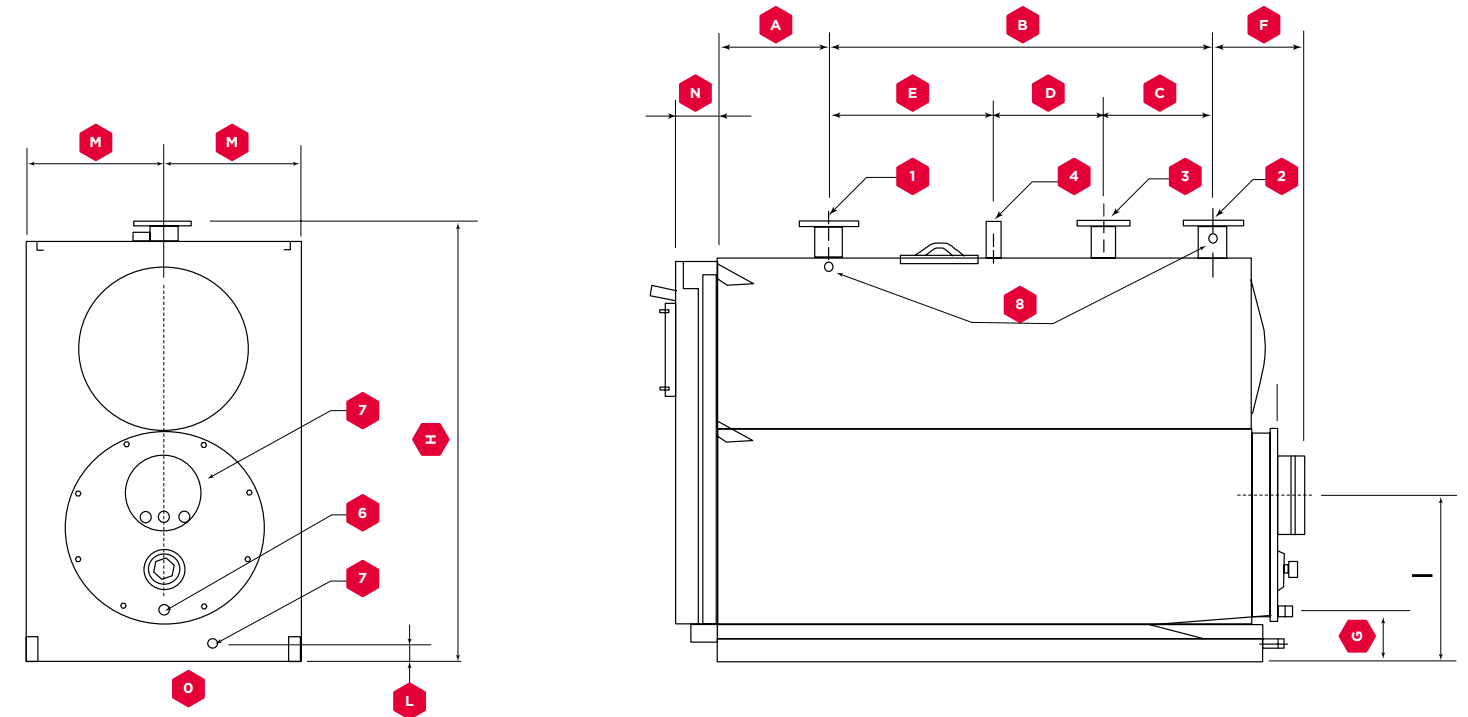

EVOJET 1450 model:

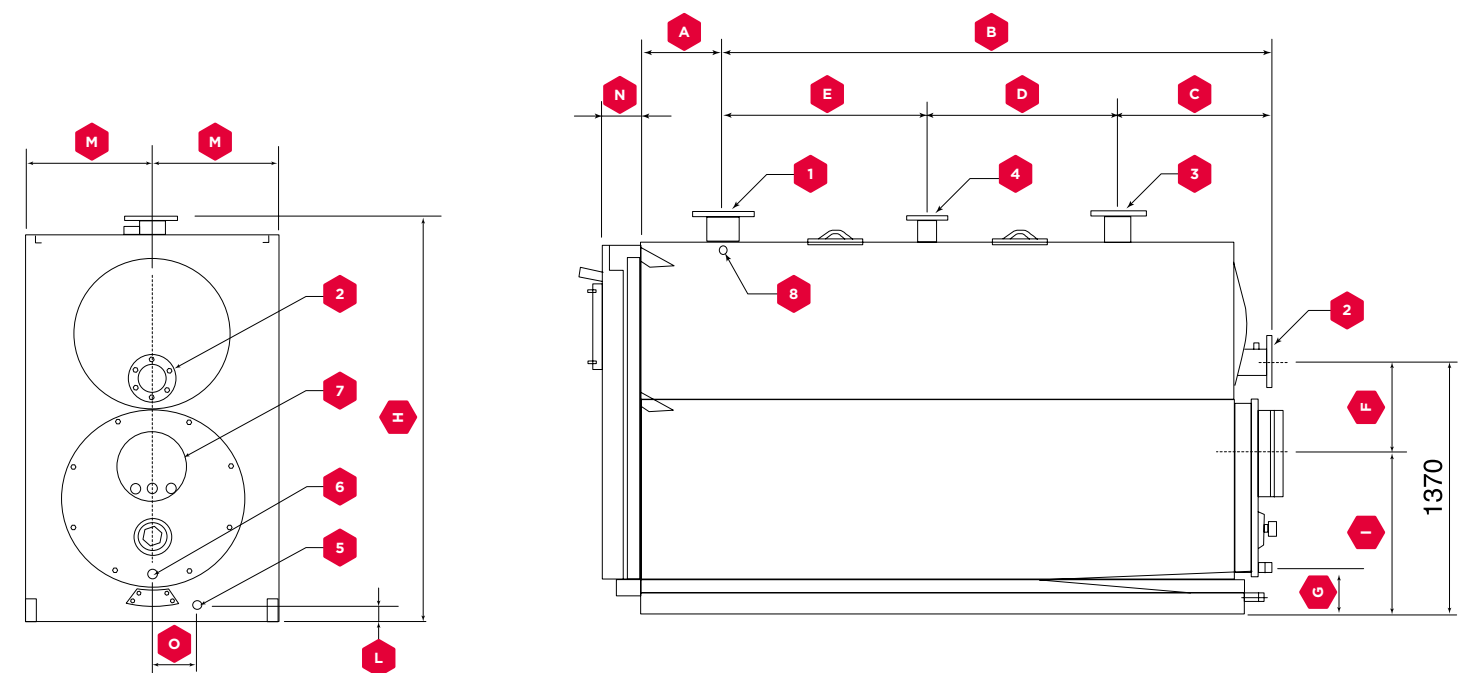

SYSTEM APPLICATION.

Ideal Evojet boilers are designed for central heating of commercial premises and also for supplying hot water via a calorifier or plate heat exchanger. They are suitable for fully pumped, open vented or pressurised systems and can be connected to heating and/or hot water systems.

They are not suitable for direct hot water supply or gravity heating/hot water systems.

BOILER	EVOJET
Maximum static head:	61 meters
Minimum static head:	10 meters
Maximum working pressure:	6 bar
Minimum working pressure:	1 bar
Maximum design flow temperature:	95°C

WATER TREATMENT.

CENTRAL HEATING

The EVOJET range of boilers have a stainless steel heat exchanger.

IMPORTANT

The application of any other treatment to this product may render the guarantee of Ideal Boilers Invalid.

Ideal Boilers recommend Water Treatment in accordance with the Benchmark Guidance Notes on Water Treatment in Central Heating Systems.

If water treatment is used Ideal Boilers recommend only the use of Scalemaster Gold 100, Fernox, MB-1, Adey MC1,

Sentinel-X100, CALMAG CM100 inhibitors and associated water treatment products, which must be used in accordance with the manufacturers' instructions.

NOTES

1. It is most important that the correct concentration of the water treatment products is maintained in accordance with the manufacturers' instructions.
2. If the boiler is installed in an existing system any unsuitable additives MUST be removed by thorough cleansing. BS 7593:2006 details the steps necessary to clean a domestic heating system.
3. In hard water areas, treatment to prevent lime scale may be necessary - however the use of artificially softened water is NOT permitted.
4. Under no circumstances should the boiler be fired before the system has been thoroughly flushed.

For further information contact:

Fernox Cookson Electronics
Forsyth Road, Sheerwater, Woking
Surrey GU21 5RZ
Tel: +44 (0) 870 601 5000

Sentinel Performance Solutions
The Heath Business & Technical Park
Runcorn, Cheshire WA7 4QX
Tel: 0800 389 4670
www.sentinel-solutions.net

Scalemaster Water Treatment Products
Emerald Way, Stone, Staffordshire
ST15 0SR
Tel: 01785 811636

Calmag Ltd.
Unit 3-6, Crown Works
Bradford Road, Sandbeds, Keighley
West Yorkshire BD20 5LN
Tel: +44 (0) 1535 210 320

Adey Professional Heating Solutions
Gloucester Road,
Cheltenham GL51 8NR
Tel: +44 (0) 1242 546700

SYSTEM REQUIREMENTS.

OPEN SYSTEMS

The system should be vented directly off the boiler flow pipe, as close to the boiler as possible. The cold feed entry should be inverted and MUST be positioned between the pump and the vent, and not more than 150mm (6") away from the vent connection.

There should be a minimum height, 500mm (20") of open vent above the cistern water level. The vertical distance between the highest point of the system and the feed/expansion cistern water level MUST not be less than 10 metres.

The information provided is based on the following assumptions:

The boiler is at the highest point of the circulation system. Systems designed to raise above the flow tappings will, of course, automatically require a minimum static head higher than shown.

The position of the open vent/safety pipe above the expansion cistern water level is given as a guide only. The final position will depend upon particular characteristics of the system. Pumping over of water into the expansion cistern should be avoided.

COLD FEED/OPEN VENT

The independent cold feed and the open vent must comply with BS 6644 and be of the following minimum size:

BOILER OUTPUT (KW)	COLD FEED	OPEN VENT
60 - 150	1" (25mm)	1¼" (32mm)
151 - 300	1¼" (32mm)	1½" (38mm)
301 - 600	1½" (38mm)	2" (50mm)
601 >	2" (50mm)	A=3.5 x Q _R

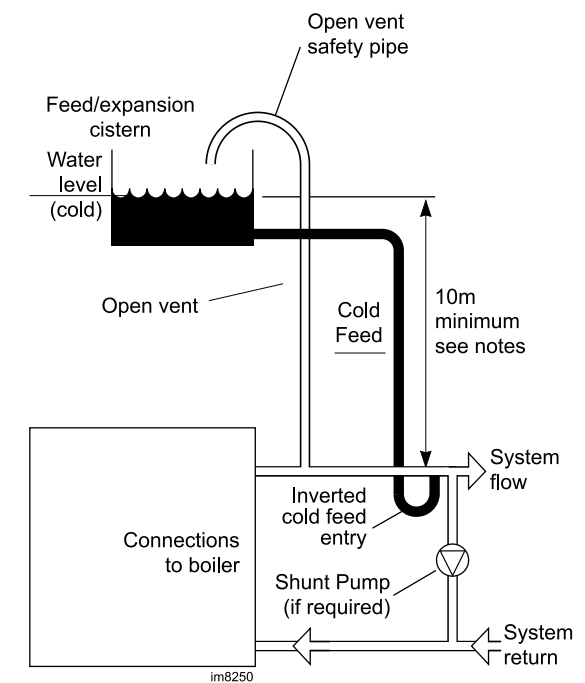

The minimum cross-sectional area of the venting pipe(s), A (in mm²) shall be determined using the equation shown here.
Where: Q_r is the rated heat output (kW)

SYSTEM REQUIREMENTS.

SEALED SYSTEMS

Working pressure 6 bar (87psi) maximum.

Particular reference should be made to BS 6644: Section 2;

Subsection 11, Guidance note PM5 "Automatically controlled steam and hot water boilers" published by the Health and Safety Executive and Water Regulations Guide.

The information and guidance given below is not intended to override any requirements of either of the above publications or the requirements of the Local Authority, gas or water undertakings.

In general, commercial closed pressurised systems are provided with either manual or automatic water make up. In both instances it will be necessary to fit automatic controls intended to protect the boiler circulating system and ancillary equipment by shutting down the boiler plant if a potentially hazardous situation should arise.

Examples of such situations are low water level and operating pressure or excessive pressure within the system. Depending on circumstances, controls will need to be either manually or automatically reset. In the event of shut down, both visual and audible alarms may be necessary.

Pressure vessels used must comply with EN13831 and must be sized on the basis of the total system volume and initial charge pressure. Initial minimum charge pressure should not be less than 0.5 bar (7.2psi) and must take account of static head and specification of the pressurising equipment.

The maximum water temperatures permissible at the point of minimum pressure in the system is specified in Guidance Note PM5.

When make up water is not provided automatically it will be necessary to fit controls which shut down the plant in the event of the maximum system pressure approaching to within 0.35 bar (5psi) of the safety valve setting.

Other British Standards applicable to commercial sealed systems are:

- BS 6880: Part 2
- BS 1212
- BS 6281: Part 1
- BS 6282: Part 1
- BS 6283: Part 4

CONDENSING BOILERS.



EVOMAX

- Wall Hung
- Aluminium Alloy Heat Exchanger
- 30-150 kW
- 30-80kW LPG available

IMAX XTRA

- Floor Standing
- Aluminium Alloy Heat Exchanger
- 80-280 kW

IMAX XTRA EL

- Floor Standing
- Aluminium Alloy Heat Exchanger
- 320-1240 kW

EVOMOD

- Floor Standing
- Stainless Steel Heat Exchanger
- Modular
- 250-1000 kW

EVOJET

- Floor Standing
- Stainless Steel Heat Exchanger
- 150-1450kW
- Condensing Pressure Jet

PRESSURE JET BOILERS.

- Floor Standing
- Range of matched burners

VISCOUNT GTS

754-1450 kW

- Cast Iron heat exchanger



VANGUARD L

420-7000kW

- Steel Shell and Tube

VICEROY GTS

450-780 kW

- Cast Iron heat exchanger



HEAT INTERFACE UNITS (HIU).

MODELS AVAILABLE:

LOGIC HIU 50 INDIRECT

LOGIC HIU 75 INDIRECT

LOGIC HIU 50 DIRECT
MEDIUM TEMP. (MT)

LOGIC HIU 50 DIRECT
HIGH TEMP. (HT)

- Indirect 50 & 75 units with twin plate design
- Direct 50 MT & HT units with single plate design
- Light weight and compact
- Ultrasonic metering options available

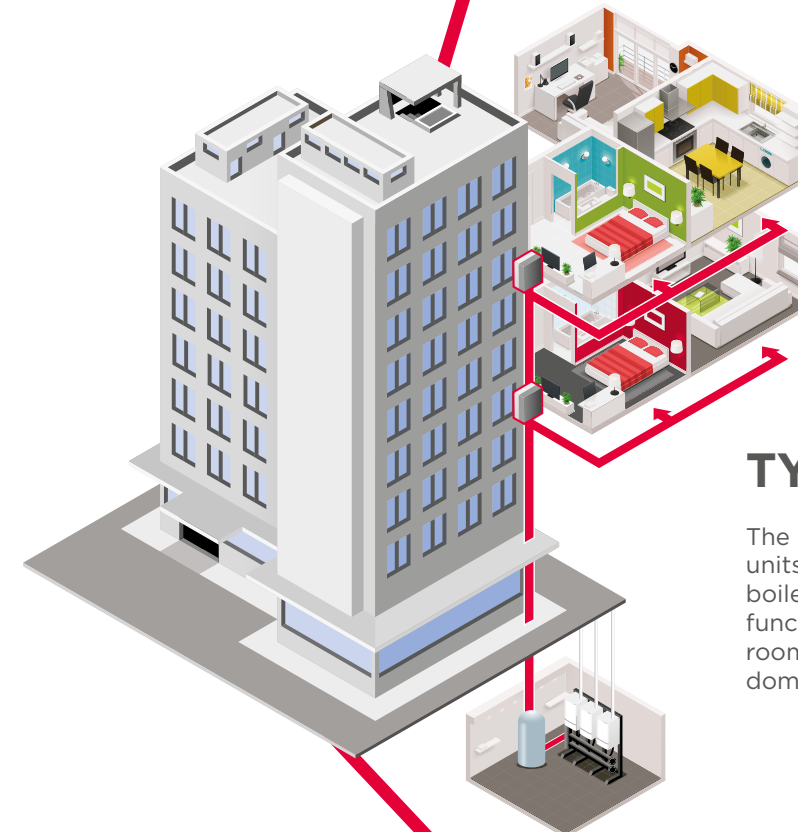

TYPICAL SYSTEM.

The Ideal Heat Interface Units are heat energy transfer units. Designed for use in conjunction with centralised boilers, district heating or central energy systems. The function is to efficiently transfer heat from the plant room to the individual dwellings central heating (CH) and domestic hot water (DHW) systems.

GET MORE WITH IDEAL COMMERCIAL.



EACH COURSE COVERS THE FOLLOWING.

- Product range overview
- Product specification
- Application and installation of products
- Electronic circuits and components
- Flue and accessory options
- Component overview, change and repair
- User controls
- Sequence of operation
- Fault finding
- Commissioning

The course involves discussion with tutors and demonstrations with practical advice.

Lunch and refreshments are provided and a certificate is awarded upon completion.

TRAINING.

These comprehensive one-day courses can be mixed and matched for individual installation and servicing companies. The course uses a simple step-by-step approach with hands on training to ensure all aspects of commissioning, servicing, and fault finding can be dealt with quickly and efficiently.

COMMERCIAL BOILER TRAINING COURSES 1 AND 2 DAYS

COURSES ARE AVAILABLE ON THE FOLLOWING PRODUCTS:

EVOMAX RANGE
(1 DAY) FREE OF CHARGE

EVOMOD RANGE
(1 DAY) FREE OF CHARGE

IMAX RANGE
(1 DAY) FREE OF CHARGE

LOGIC HIU
(1 DAY) FREE OF CHARGE

CONCORD CX RANGE
(1 DAY) £80 INC VAT

CONCORD SUPER RANGE
(1 DAY) £80 INC VAT

CONTACT TRAINING

Tel: 01482 498432
techincal.training@idealboilers.com

BOOK ONLINE AT
idealcommercialboilers.com



SERVICE & SUPPORT.

At Ideal, we are committed to delivering the highest levels of customer service. With over a century of experience in the heating industry, we know how important confidence and trust is to our customers.

You can be confident to know that you're partnering with a British manufacturer that's supported by a dedicated national service team, delivering help and advice to you and your customers throughout the year.

Our rigorous research and development procedures and manufacturing quality control checks, ensures that all of our products are produced to the highest standards; delivering total comfort and peace of mind.

The call centre team, based in Hull, East Yorkshire, is comprehensively trained to provide tailored advice. All calls will be answered by trained members of staff who will take ownership of the call. All of our trained staff are on-hand to assist with enquiries or help diagnose and resolve faults over the telephone. Should that not be possible, we will arrange an appointment for one of our engineers to visit. Our dedicated team of engineers are fully trained to exacting standards and are all Gas Safe registered.

IDEAL COMMERCIAL HEATING SERVICE.

SALES

Tel: 0844 5436060
Fax: 0844 5436181

TECHNICAL

Tel: 01482 440237
Fax: 01482 498621

commercial.services@idealboilers.com

 JOIN THE CONVERSATION @idealboilers

THE IDEAL COMMERCIAL BOILERS PRODUCT RANGE

Boiler output	kW	20	40	100	150	200	600	800	1000	1500	3500	
Condensing Boilers												
Evomax			30-150									
Evomax Cascade			30-600									
Imax Xtra				80-280								
Imax Xtra EL							320-1240					
Evomod							250-1000					
Evojet						150 - 1450						
High Efficiency Boilers												
Super Series 4							450-600					
Super Plus							500-600					
Pressure Jet Boilers												
Viceroy GTS							450-780					
Viscount GTS								754-1450				
Vanguard L							420-7000					

APPROVAL

These appliances are certified to G.A.D. 90/396 and B.E.D. 92/42 Safety and Performance Directives for gas boilers.

Ideal Commercial Boilers pursues a policy of continuous improvement in design and performance of its products and reserves the right to vary specification without notice. Statutory rights of the consumer are not affected.

PLEASE NOTE:

The information in this brochure was correct at the time of going to print. Ideal Commercial Boilers reserve the right to make any modifications to product specifications or any other details, without prior notification. For further clarification, please enquire in writing to the head office address (address below).

IDEAL COMMERCIAL BOILERS

P.O. Box 103
National Avenue
Kingston Upon Hull
HU5 4JN

T: 0844 5436060
F: 0844 5436181

www.idealcommercialboilers.com

 @idealboilers  Ideal Boilers

