

automatic oil burners. MODEL C1

MODEL

C1

The Nu-way C1 pressure jet burner is a small compact fully automatic burner designed to meet the requirements of all international markets. The burner is fitted with a simple adjustable head to ensure optimum efficiency and fuel economy. The C1 also includes a patented air control device to ensure quiet and smooth operation.
Available for on/off operation only.

FUEL

Light distillate oil Class D (1.5—5.5cST @ 40°C).

FUEL SYSTEM

Suitable for single pipe gravity feed or two pipe suction lift systems. A fuel filter is provided fuel connection $\frac{1}{4}$ " BSP.

CONSTRUCTION

A monobloc metric design, using fastenings to ISO standards. Suitable for flange mounting. The burner is fixed to the mounting flange by a single screw. This enables the burner to be easily removed for servicing. The fan and inner assembly are accessible by removing the cover plate.

AIR CONTROL

Metal inlet register.

CONTROLS

Flame supervision by photo-electric cell with sequence controller

The burner may be controlled by suitable thermostats, time switches, frost stats, etc.

OPTIONAL EXTRAS

Quickly detachable moulded cover.

APPROX. WEIGHT

11 kg,

ELECTRICAL DATA

Mains supply (V)	230+10%—15%
	1 ph 50 Hz
Burner motor (W)	75
(hp)	1/10
	2700 rev/min, capacitor start
Burner start current (A)	1.0
Burner run current (A)	0.6
Ignition by direct spark from double-wound and suppressed transformer secondary 10 kV 23 mA	
Centre tap to earth	
Recommended minimum mains cable size 1mm ²	
HRC Fuse 6amp.	

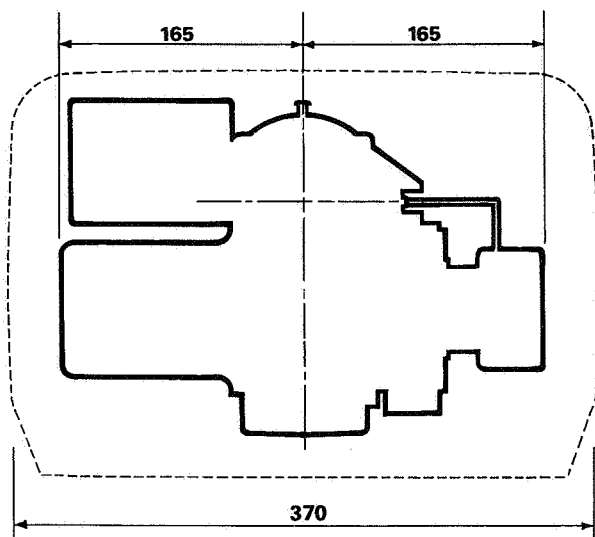
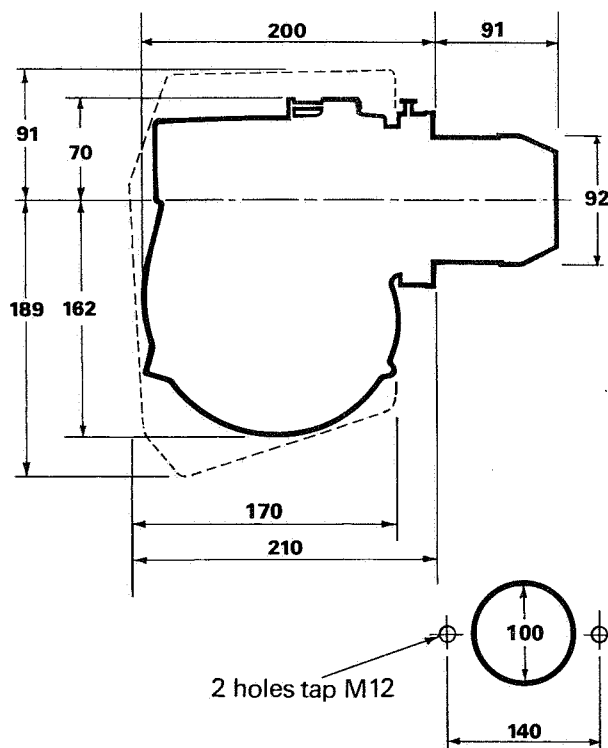

NU-WAY

BURNER DATA

Burner Model	Minimum Burner capacity†			Maximum Burner capacity†			Cone diameter mm	Minimum Burner Throughput*		Maximum Burner Throughput*		Nozzle Spray Angle ††
	kW	kcal/h x 10 ³	Btu/h x 10 ³	kW	kcal/h x 10 ³	Btu/h x 10 ³		Litres/h	USgal/h	Litres/h	USgal/h	
C1R**	14.6	12.6	50.0	24.9	21.4	85.0	73	1.36	0.36	2.35	0.62	80°
C1S	25.0	21.5	85.4	55.0	47.2	187.4	73	2.38	0.63	5.19	1.37	60°
C1T	55.1	47.3	187.8	80.6	69.3	275.1	73	5.22	1.38	7.65	2.02	60° & 45°

INSTALLATION

Flue The top of the chimney should be above all roofs within a radius of 10 m. If a cowl is fitted, remove it. Ensure that the flue pipe from the appliance finishes flush with the inside wall of the chimney.

If draught over the fire exceeds 0.02 kPa (2mm wg: 0.08 in wg) draught stabiliser should be fitted in a position recommended by the appliance maker. Draught over the fire when the burner is operating should be between 0.05 and 0.012 kPa (5.0—1.2mm wg : 0.05—0.2 in wg).

Fuel Storage and Handling The provisions of BS.2869 will normally ensure that the fuel will be of adequate performance when stored and handled without heating. However, some users may need to provide a bulk storage installation to a higher standard in order to prevent the fuel waxing under sustained cold and exposed conditions. Class D winter grade fuel is susceptible to waxing at temperatures below -9°C and Class D summer grade at temperatures below 0°C.

Fuel suppliers recommendations should be followed to suit site conditions.

Fuel Supply (and, where fitted, return) pipes should consist of copper tube (NEVER galvanised steel), the final connection to the burner pump inlet port being made with the length of flexible pipe supplied with the burner. Joints should be made with compression fittings, not by soldering.

When gravity feed is used (the most common), the maximum head should not exceed 4 m (equivalent to a pressure of 35 kPa).

On installations where the fuel tank is situated below the level of the burner the maximum suction permitted is 40 kPa (300mm Hg) and a two-pipe (supply and return) fuel supply system MUST be used.

Note that the pump is factory set for single pipe installation. When using a two pipe system refer to the sketch opposite for pump modification.

If installation is a two-pipe system, it is essential to ensure that the return pipe is not obstructed in any way, eg by a plug, closed valve, etc. Any obstruction may damage the pump.

Remove the purge plug. Connect purge port to suitable container.

Electricity Supply Connect burner to electricity supply, thermostats, time switches, etc., as appropriate.

Start burner, illuminate photo-cell with a light source stopping it as soon as fuel flows into the container.

On single pipe (gravity fed) systems, the pump should be primed under gravity from the tank and not by running the pump mechanically. If a two-pipe system is used, the suction line will require priming before energising the pump mechanically.

The pump may need bleeding also, if the oil storage tank is allowed to drain completely.

Notes:

Diffuser diameter is 73 mm on R & S models and 60 mm diameter on T model (all 24 mm i/d).

Pump pressure of 862 kPa (8.8 Kg/cm² = 125 psi) for S and T models, and 772 kPa (7.0 Kg/cm² = 100 psi) for R model, is factory-set standard.

† Ratings are based on negative draught over flame of 0.005 kPa (0.5 mm wg = 0.02 in wg).

†† Nozzles are Monarch AR or Steinen Q.

* Based on calorific value of 10.6 kW/litre (137,500 BTU'S/US gal).

** Available by special arrangement only.

Modifying a fuel unit to two-pipe from one-pipe installation.

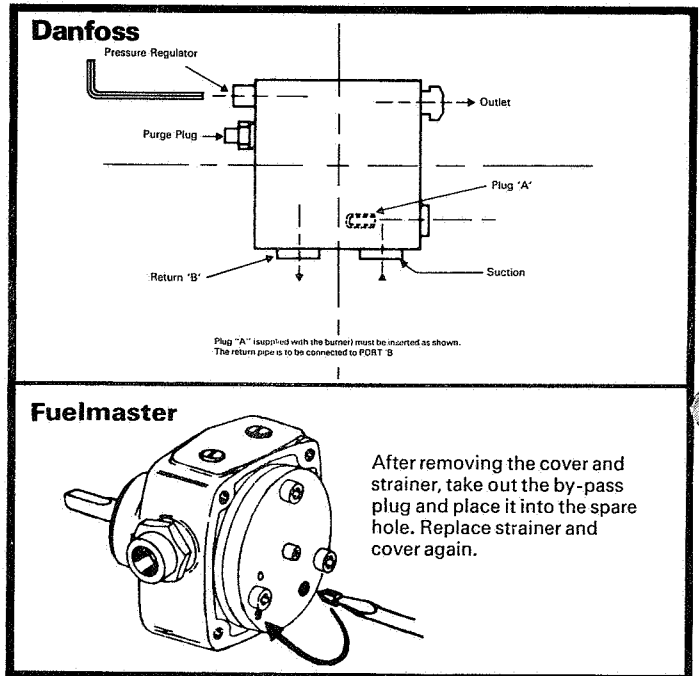

Important: When using a two-pipe system it is essential for the return line to go direct to tank without obstruction.

Diffuser/Air cone relation (mm).

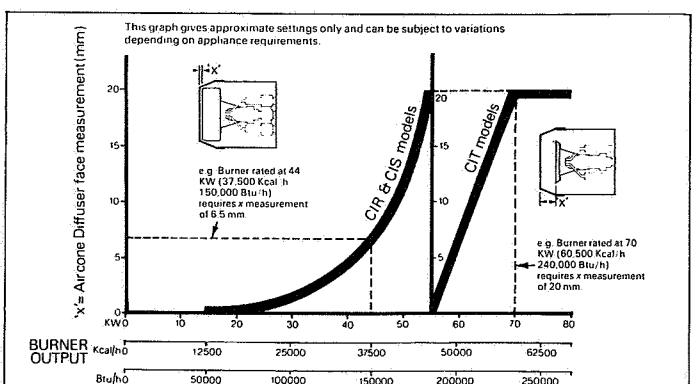

One-pipe system – to be used only when there is a positive pressure in the suction line.

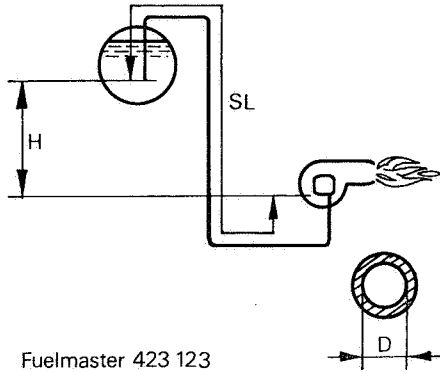

Fuelmaster 423 123

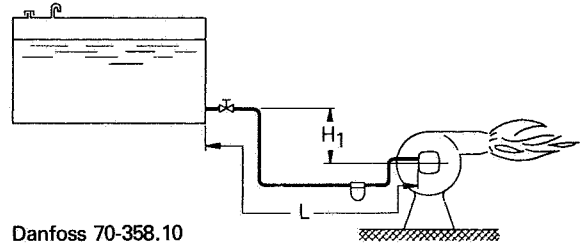

Danfoss 70-358.10

FUELMASTER		4,3 cSt (20°C)								
In meters		D in millimeters								
		4	5	6	4	5	6	4	5	6
H ↑	4	100	100	100	90	100	100	46	100	100
	3	100	100	100	78	100	100	41	90	100
	2	90	100	100	65	100	100	35	80	100
	1	75	100	100	54	100	100	28	67	100
H ↓	-0	60	100	100	42	100	100	21	52	100
	-0	60	100	100	42	100	100	21	52	100
Atomizer Output		3.0 Litres/h (0.8 USG/h)			3.8 Litres/h (1.0 USG/h)			7.6 Litres/h (2.0 USG/h)		

DANFOSS		4,3 cSt (20°C)								
H ₁ m	φ4 mm	φ5 mm	φ6 mm	φ4 mm	φ5 mm	φ6 mm	φ4 mm	φ5 mm	φ6 mm	
4,0	77	100	100	39	94	100	25	60	100	
3,5	67	100	100	33	82	100	21	52	100	
3,0	56	100	100	28	67	100	18	44	91	
2,5	46	100	100	23	56	100	15	36	74	
2,0	35	86	100	18	43	89	11	27	57	
1,5	24	60	100	12	30	63	8	19	40	
1,0	14	35	72	7	17	36	5	11	23	
0,5	4	9	19	2	4	9	1	3	6	
Nozzle capacity	1.9–2.7 Litres/h (0.503–0.713 USG/h)			2.7–4.9 Litres/h (0.713–1.297 USG/h)			4.9–7.5 Litres/h (1.297–1.996 USG/h)			

Two-pipe system – to be used when a vacuum may occur in the suction line.

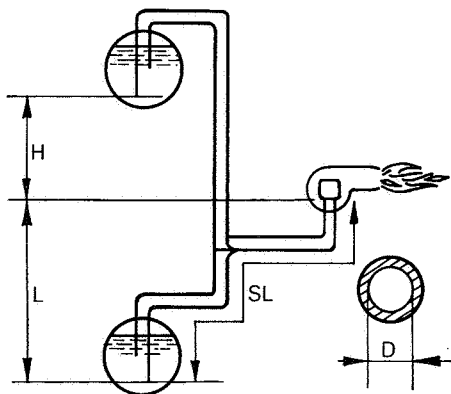

Fuelmaster 423 124

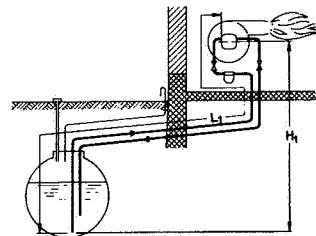

Danfoss 70-359.10

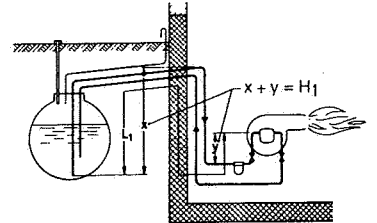

Danfoss 70-360.10

FUELMASTER		4,3 cSt (20°C)		
H	In meters	D in millimeters		
L		6	8	10
H ↑	4	40	100	100
	3	35	100	100
	2	29	91	100
H ↓	1	24	75	100
	-0	19	59	100
L ↓	-1	13	43	100
	-2	8	27	69
	-3	—	11	29
	-4	—	—	11

DANFOSS		4,3 cSt (20°C)		
H ₁ m	φ6 mm	φ8 mm	φ10 mm	
4,0	34	100	100	
3,5	32	100	100	
3,0	30	95	100	
2,5	28	89	100	
2,0	26	82	100	
1,5	24	75	100	
1,0	22	68	100	
0,5	20	62	100	
0,0	17	55	100	
-0,5	15	48	100	
-1,0	13	41	100	
-1,5	11	35	85	
-2,0	9	28	68	
-2,5	7	21	52	
-3,0	5	14	35	
-3,5	0	8	19	
-4,0	0	0	0	

NU-WAY

OPERATION

To start burner turn main electricity isolating switch and, where fitted, separate burner switch, to ON.

The burner can be stopped in an emergency by opening the electrical switch provided in the line between the burner and the electricity supply.

There is a pre-purge period during which the ignition is switched on. If a magnetic oil valve is fitted the motor will run.

At the end of this period magnetic oil valve (if fitted) opens: if magnetic oil valve is not fitted motor starts. Burner lights.

After a further period the ignition is switched off and the burner continues to run until it is switched off by:-

- (a) the control thermostat contacts opening upon the room or water temperature being reached
- or (b) safety or limit thermostat contacts opening
- or (c) burner is switched off manually.

If, during start up, the flame fails to be established the photo cell will detect this and will shut down the burner and the red "lock out" lamp in the sequence control box is automatically lit.

If, during normal running, the flame is extinguished the ignition spark is restored within 1 second. If no magnetic oil valve is fitted the motor stops. After 15 seconds the motor starts again. If burner fails to light it goes to "lock out" after 15 seconds.

If magnetic oil valve is fitted oil is cut off but motor continues to run. After 15 seconds oil valve opens and burner attempts to light. If it fails to light burner goes to "lock out" after 15 seconds.

The manual reset button, also on the sequence control box, should not be operated until at least 30 seconds after the burner has been 'locked out'.

ELECTRICAL CONNECTIONS

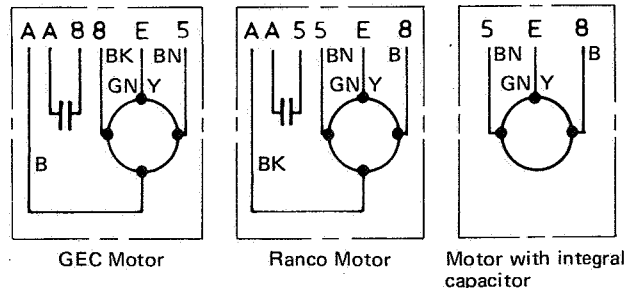
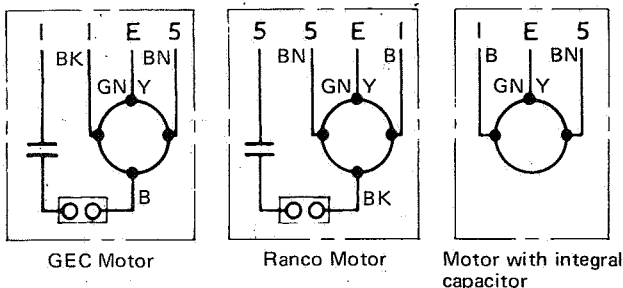
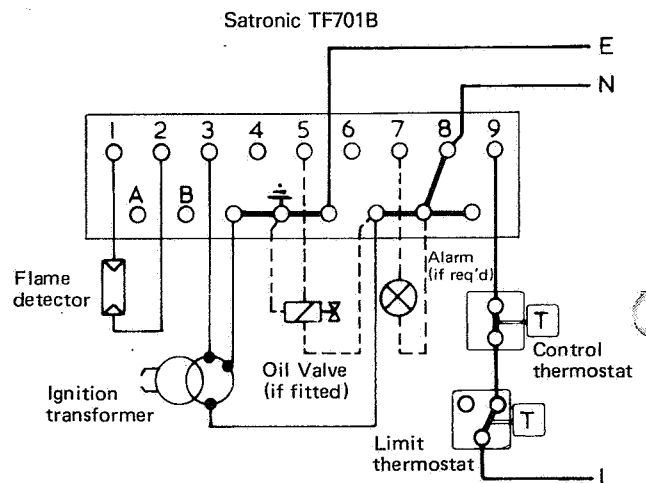
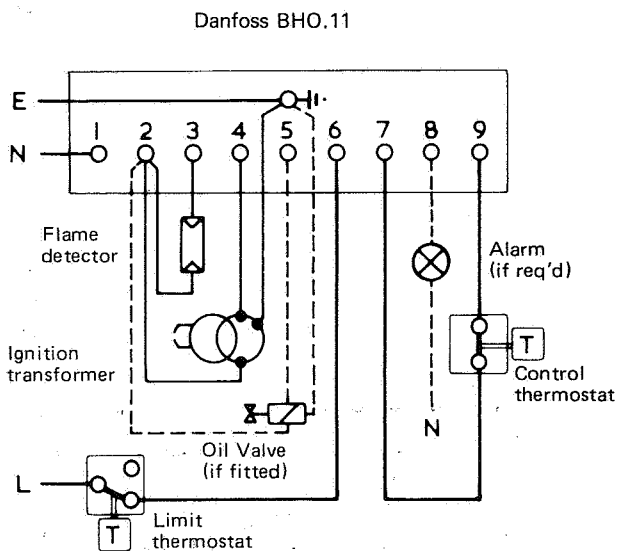

If oil valve is fitted, wire as shown and change motor (and capacitor if applicable) wires from 5 to 7.

If oil valve is fitted, wire as shown and change motor (and capacitor if applicable) wires from 5 to 4.

FAULT FINDING

Motor fails to start. Check that power is available to the burner. Check all fuses in the supply to the burner. Check that the contacts of both control and safety limit thermostats on the appliance or in the room are closed, and therefore "calling for heat". If these thermostat contacts are not closed check the thermostat settings.

Motor starts but burner will not light. If the flame is not established the burner will be stopped and 'locked out' after a safety period of 15 seconds: a red warning light is illuminated on the sequence control box. The manual reset button, also mounted on the sequence controller, should not be operated until at least 30 seconds after the burner has been 'locked out'.

Ascertain whether oil is being sprayed by the nozzle.

If oil is passing through nozzle, check that there is a spark at the electrodes. Check all connections including high voltage leads.

Check electrode gap and correct if necessary.

Ensure that electrodes are not short circuited and that their insulators are not cracked.

If there is no oil spray check that there is an oil supply to the burner and that all valves are open. Check that nozzle is not blocked. Ensure that all filters are able to pass oil. Check that the solenoid valve, if fitted, is open. Check that fuel pressure delivered by the pump is correct.

Unstable pump pressure. Check that the pump has been correctly primed by disconnecting return pipe from pump (on two-pipe systems); air-free fuel should flow out when the pump is run. On single pipe systems remove the purge plug to ascertain that air-free oil flows out.

On installations where the burner pump has to lift fuel from the tank check that all pipework and connections on the suction side are free of leaks and that there are no blockages.

Burner starts, then stops after a short time. Check that photo-cell is clean and correctly located. Check air damper setting and readjust as necessary.

Flame unstable, burner stops. Check for fuel supply fault, eg partial blockage of fuel supply pipe. Check nozzle atomisation good etc.

Burner stops after satisfactory running period. If flame fails during normal running period, the ignition will be switched on again. If the flame is not re-established after a period the burner is stopped and 'locked out', and a red warning (lock out) light illuminated on the sequence control box.

If the flame is re-established during this period the ignition is switched off and the burner will continue to operate normally.

MAINTENANCE

Before carrying out any work on the burner ensure that the electricity is switched OFF.

Filters A filter is fitted within the pump. To gain access remove pump end-plate (4 socket head screws).

Withdraw filter and clean it in paraffin, petrol or other solvent, using a stiff brush.

Replace filter and pump end-plate.

A filter should also be fitted in the fuel supply pipe. If fitted with a disposable element this should be replaced at least once per year, the frequency depending on the needs of the installation and the cleanliness of the fuel.

If the filter has a cleanable element this should be cleaned, at suitable intervals, in exactly the same way as has been described for the pump filter.

Motor The motor requires no maintenance: it has bearings which are factory lubricated for the life of the motor.

Fan If fan is damaged or becomes loose on the motor shaft the motor must be removed (4 screws) from the burner casing. Correct position of fan is such that a 9.5 mm diameter bar can just be passed between motor spigot and back of fan.

Landis & Gyr LAI.4

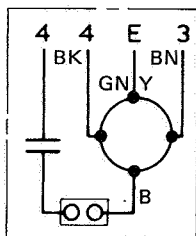
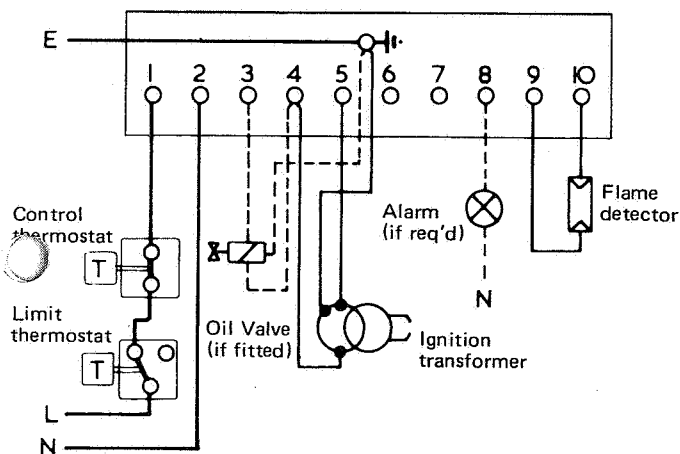

GEC Motor

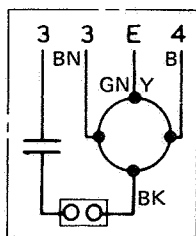

Ranco Motor

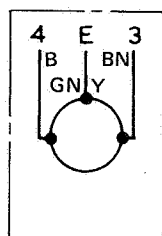

Motor with integral capacitor

If oil valve is fitted, wire as shown and change motor (and capacitor if applicable) wires from 3 to 7.

NU-WAY

MAINTENANCE

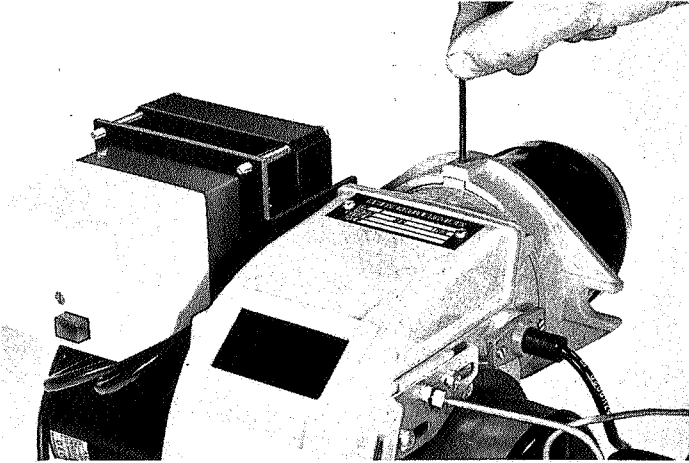

General view of the burner showing single socket grub screw which secures burner to mounting bracket: latter is bolted to boiler front plate. Sequence control box is to left of burner casing and is secured in position by a single screw visible between reset button and light.

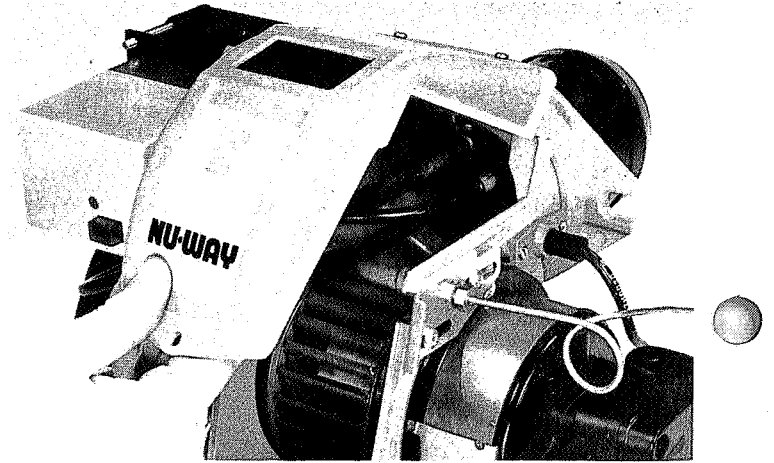

Cover may be withdrawn after removal of single screw beneath name plate. Ignition electrode leads may then be disconnected.

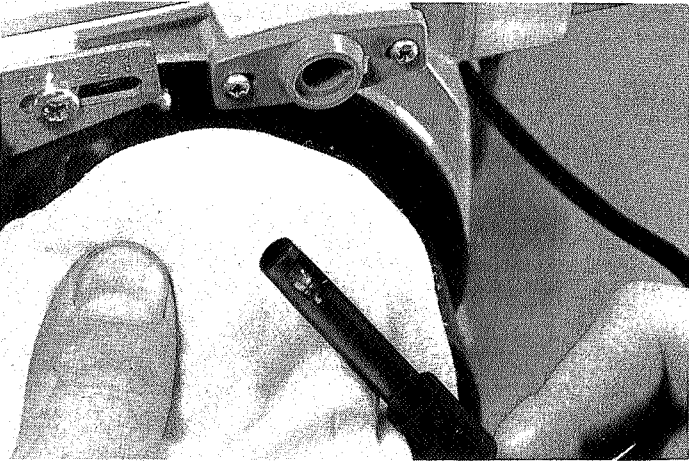
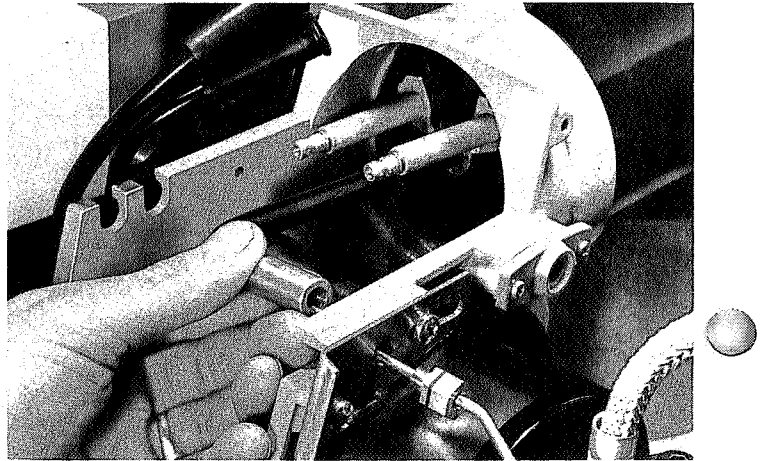
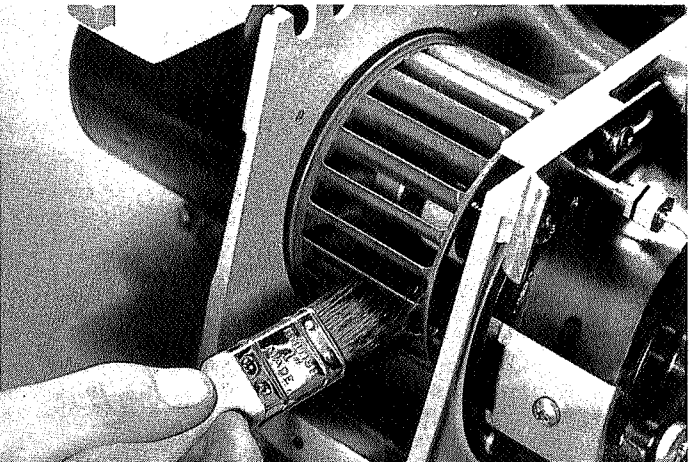

Photo-cell is removed from burner for cleaning. Do not touch cell with the fingers: use only a clean, dry cloth for cleaning.



Before attempting to remove inner assembly withdraw photo-electric cell from its housing on right side of burner. Tubing nut and lock nut is fully unscrewed to release inner assembly which may now be withdrawn from burner.



Cleaning the fan runner: use stiff brush.

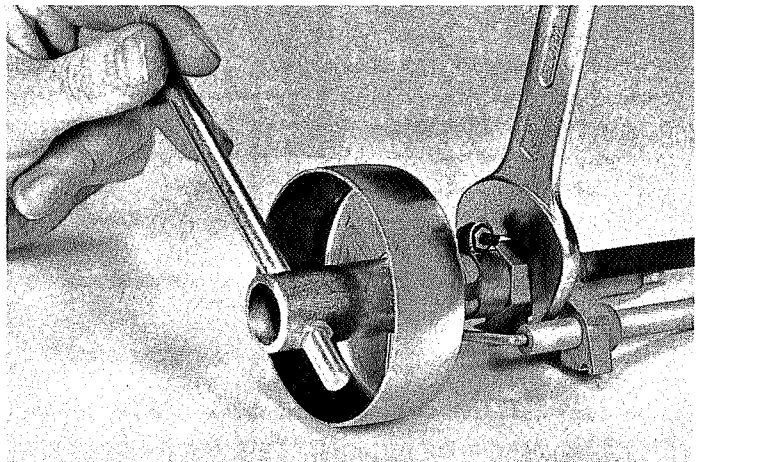

Nozzle is removed from inner assembly using a tube spanner. Fit nozzle to burner inner assembly by hand: use spanner only for final tightening.

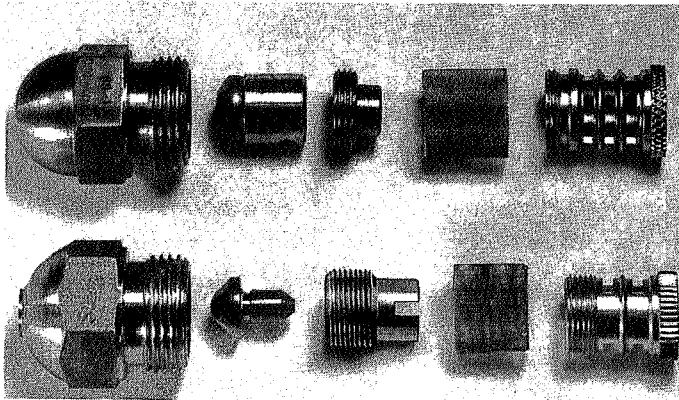

Dismantle nozzle itself to enable internal filter to be cleaned. Do not use any metal or wood to remove deposits. Wash in solvent. Wipe off any remaining dust using a clean, lint-free rag. Illustration shows correct assembly sequence for (*above*) Monarch and (*below*) Steinen nozzles.

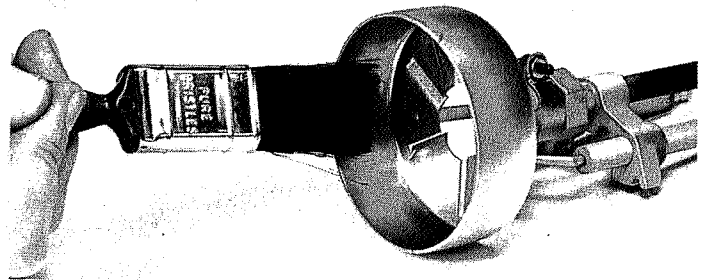

Air diffuser should be cleaned using a stiff brush.

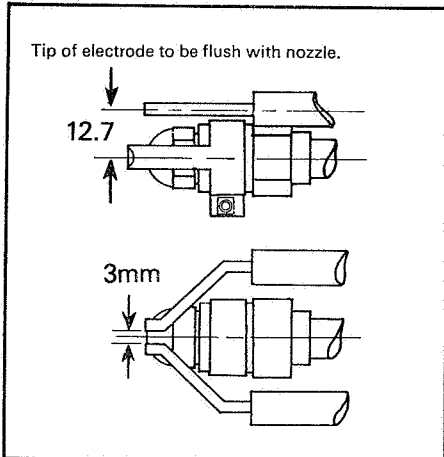

Electrodes should be set to these dimensions to ensure trouble free ignition. Dimensions are in millimetres.

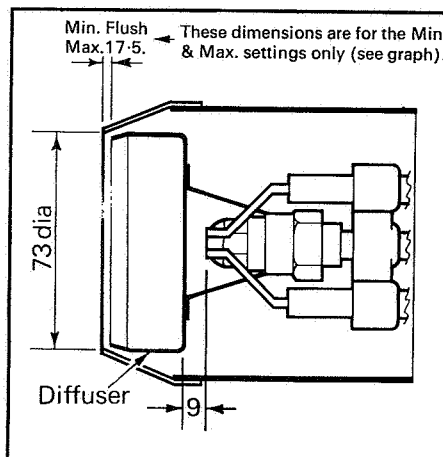

Adjustable head arrangement CIR & CIS burners.

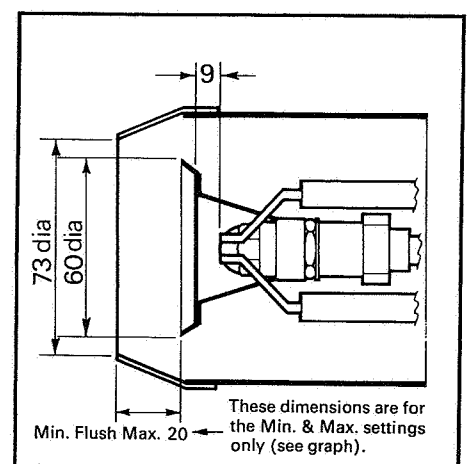

Adjustable head arrangement CIT burner.

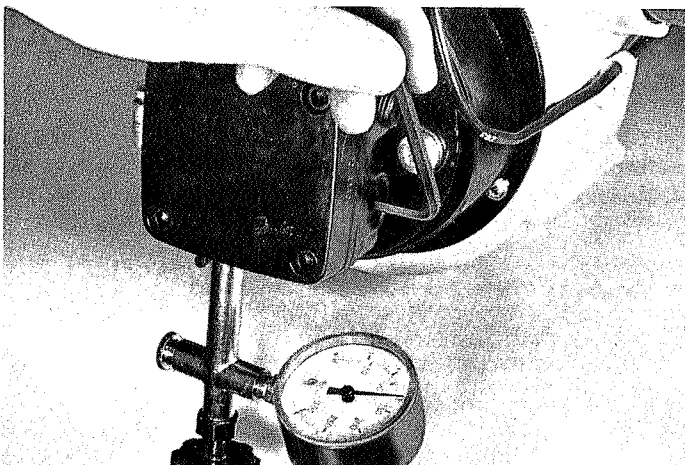

Adjusting pump delivery pressure. Normal pressure is 862 kPa (8.8 Kg/cm²=125 psi)

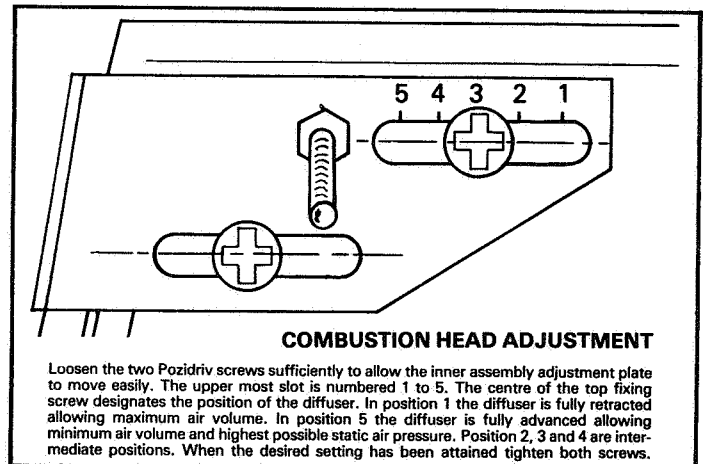

NU-WAY

service centres

BELFAST

Boucher Centre, 69 Boucher Rd.,
Balmoral Ind. Estate, Belfast BT12
Tel: Belfast 668977

DROITWICH

Vines Lane, Droitwich WR9 8NA
Tel: (0905) 772331

EAST KILBRIDE

7 Carron Place
Kelvin Industrial Estate
Scotland G75 0YL
Tel: East Kilbride 35381-2

DISTRIBUTORS

DUBLIN

Hevac Ltd.,
Ballymount Road
Clondalkin
Co. Dublin
Tel: Dublin 519411

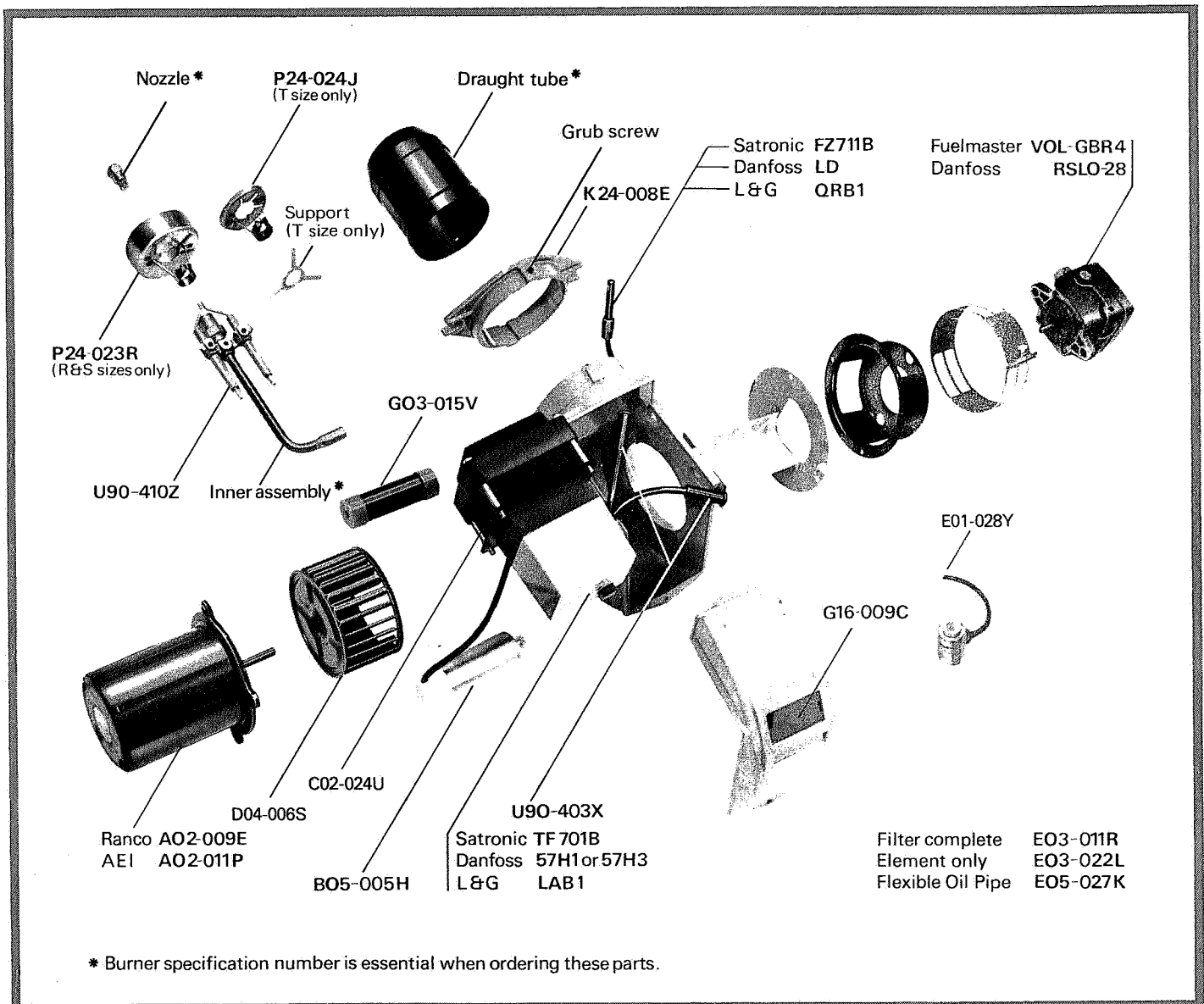

Nu-way Limited Droitwich, WR9 8NA, England

Telephone: Droitwich (0905) 772331
Telex: 338551 Cables: JASNU DROITWICH

Nu-way policy is one of continuous improvement. The right to change prices and specifications without notice is reserved.