

Flue Accessories & Fitting Guide

Potterton Promax Store

Ø 60/100 Flue Systems Ø 80/80 Twin Pipe Vertical Flue Systems
Ø 80/125 Flue Systems Plume Displacement Kit (Ø 60/100 Flue Systems)

**READ THESE INSTRUCTIONS IN CONJUNCTION WITH THE BOILER
INSTALLATION MANUAL BEFORE FITTING THE FLUE**

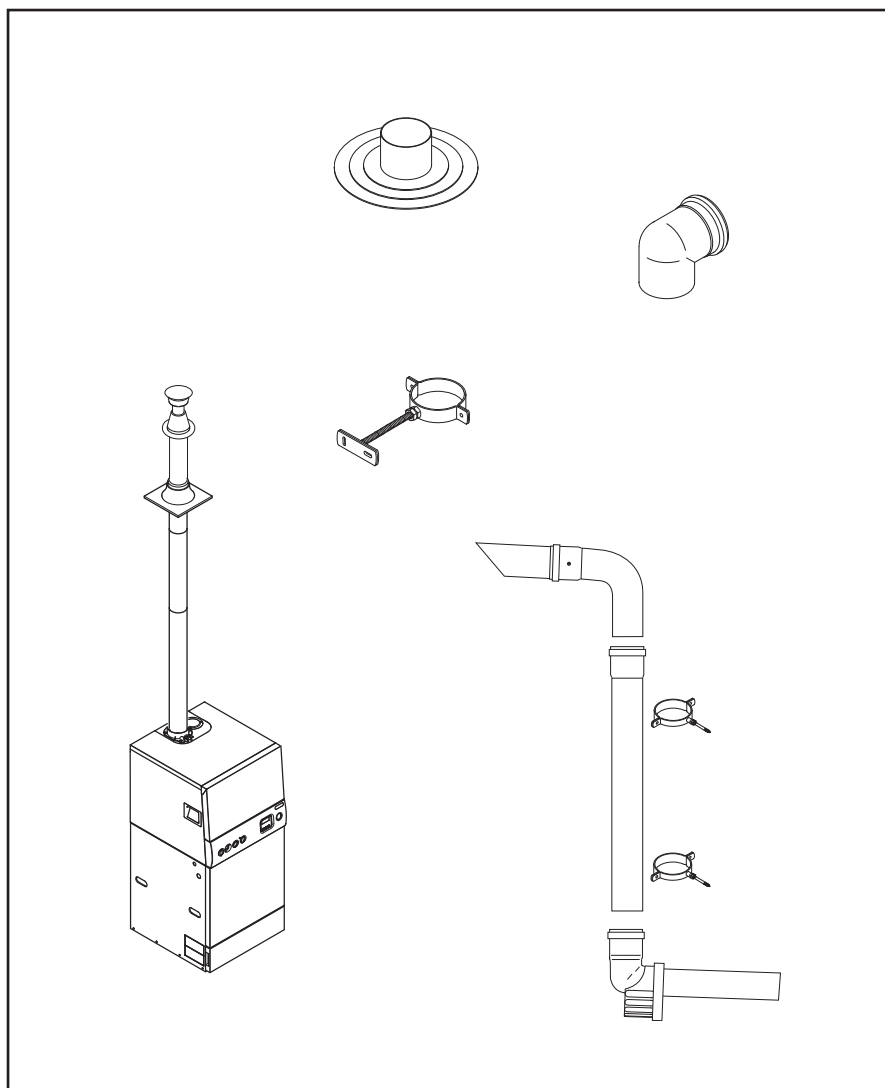

IMPORTANT NOTE: This document will assist in the correct installation of the various flue & chimney systems described within. However, it is the responsibility of the installer/Gas Safe registered commissioning engineer to ensure that the flue & chimney system is fitted safely and in compliance with the relevant standards and practices in force in the country of installation.

Please leave these instructions with the Installation & Servicing Instructions.

IMPORTANT NOTES

Please read before continuing with the flue installation !

- Flue systems must be constructed using only components approved for use with the appliance and installed in accordance with BS 5440 Part I, any manufacturers instructions and Part J of the Building Regulations.
- In order to meet the requirements of the Gas Safety (Installation & Use) Regulations, provision should be made such that all flue joints and supports can be inspected.
- The flue system should have a continuous fall back to the boiler (1.5° to 3°) and be **supported at least once every metre** using suitable support brackets (where shorter straight lengths are used, for example between two bends, these should also be supported).
- Ensure that there are no 'dips' in the flue system.
- Consideration must be given to protect exposed parts of the outlet duct where accidental touch may occur.
- **All fittings should be correctly engaged and secured where necessary. Expansion Gap details must be observed on twin pipe 80/80 systems (Flue Group N).**
- Flue extensions can be cut to length if necessary. The cut end should be square and de-burred to prevent damage to seals when assembling to a fitting.
- The **MAXIMUM** total equivalent lengths are:-
10 metres (60/100 system - vertical & horizontal)
20 metres (80/125 system - vertical & horizontal)
15 metres (80/80 twin pipe)
- If the flue system is to be fitted prior to the boiler, temporary precautions must be taken to prevent rain entry into the room of installation. Any precautionary measures must be removed prior to fitting the boiler.
- It is the responsibility of the installer to ensure the integrity of the flue & chimney system before commissioning the boiler.

FLUE TERMINATIONS

It is important to protect building structures from the condensate plume produced from the boiler exhaust duct flue terminal. This should always be directed away, by using plume deflector or PDK if necessary. Where PDK's terminate under balconies it is recommended to extend the terminal beyond the balcony.

TERMINAL GUARDS

- It is necessary to use a Terminal Guard where there exists the risk of blockage and/or damage to the terminal or air intake of the PDK, and also in instances where there is a risk of injury to people, including the possibility of exposure to high temperatures.
- Any terminal that is less than 2 metres above finished floor or ground level must be guarded. This also applies when terminals are positioned above flat roofs and balconies to which there is regular unimpeded access.
- A guard must not prevent correct & safe operation of the appliance the terminal is connected to.

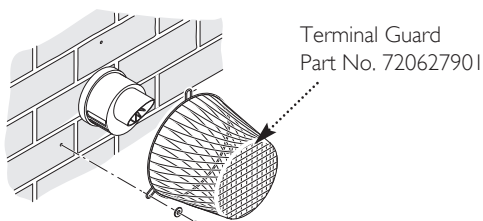

CHIMNEYS & FLUES IN VOIDS

"Voids" includes ceiling & floor voids, purpose-built enclosures, service risers, certain types of roof space and any other enclosure that restricts access to the chimney.

The need to inspect applies to concentric and twin systems, and both the air and flue ducts of the latter.

The requirement to inspect does not apply where a boiler is mounted on the wall and the chimney system runs within the building structure (e.g. direct from the rear of the boiler through the wall to outside).

A proprietary liner containing a chimney system is also exempt, providing there are no joints in this part of the system.

B.S. 5440-I, Gas Safety (Installation & Use) Regulations and any Gas Safe Register Technical Bulletins must be consulted.

Chimney systems must not pass through other properties because access may not always be available for inspection.

Access must be provided at strategic locations to allow inspection to confirm:-

- i) the system is continuous
- ii) all joints are correctly assembled & sealed
- iii) adequate support has been provided
- iv) any "fall" or drain point required for condensation has been provided

Inspection hatches must be permanent, be of sufficient size and number, located such that no special equipment (e.g. an endoscope) is required to perform inspection and have suitable fire resistance.

Inspection hatches must comply with the following:-

- i) all voids containing a concealed chimney system must have at least one hatch
- ii) hatches must be at least 300mm x 300mm
- iii) no joint in the flue must further than 1.5m from the edge of the nearest hatch
- iv) hatches should, where possible, be located at changes of direction in the flue
- v) where iv) is not possible bends should fully visible from both directions

As far as practicable hatches should be installed in non-habitable areas such as cupboards and passageways.

A Gas Safe Registered engineer should always be consulted when considering the positioning of inspection hatches.

The presence of other services and pipework may influence the location of inspection hatches. In exceptional circumstances these other services may have to be re-routed to allow suitable positioning of a hatch.

Installation of any hatch shall not compromise the integrity and safety of the property. If necessary consult Local Building Regulations or Building Control Office for guidance. In all instances the hatch manufacturers instructions should be consulted and adhered to.

FIRESTOPS

Use of firestops may be required where the flue or chimney passes between rooms or spaces. Any firestop or collar **MUST NOT** prevent the linear expansion or contraction of the flue or chimney

MAKING GOOD

Where the flue system passes through an external wall the joint should 'made good' by use of suitable sealant or building materials and the flue trims supplied if required.

FLUE ACCESSORIES

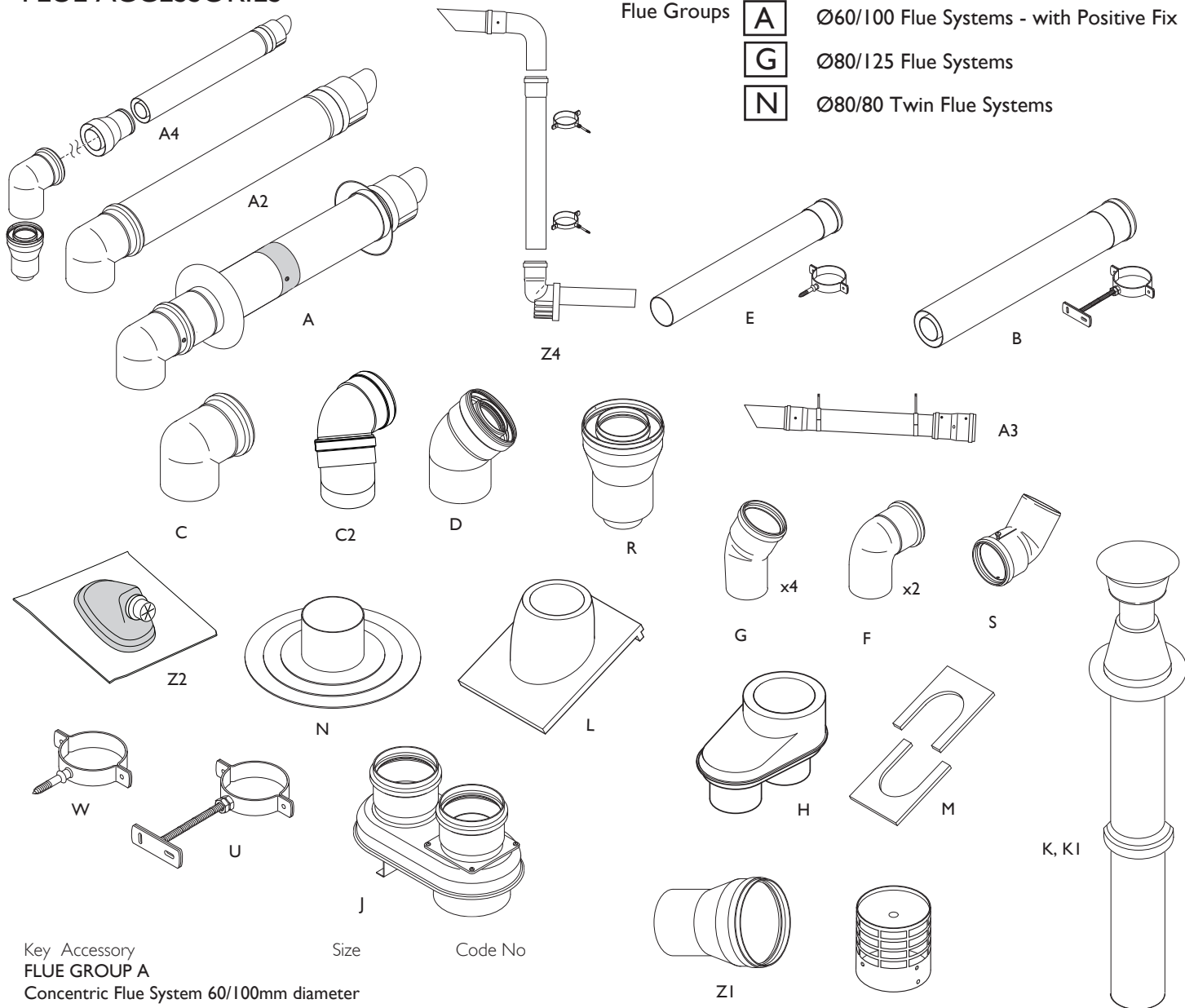

Flue Groups **A** Ø60/100 Flue Systems - with Positive Fix
G Ø80/125 Flue Systems
N Ø80/80 Twin Flue Systems

Key Accessory	Size	Code No
FLUE GROUP A		
Concentric Flue System 60/100mm diameter		
A Telescopic Flue (Black)	315-500mm	720598701
A Telescopic Flue (Brown)	315-500mm	720642701
A Telescopic Flue (White)	315-500mm	720599401
A2 Horizontal Flue - Fixed Length	100-685mm	7222019
(all A & A2 Flues include 1 x Low Profile Bend)		
A3 Under Balcony Extension - White		7211039
A3 Under Balcony Extension - Black		7211041
B Flue Extension (includes support bracket)	1000mm	720648801
B Flue Extension (includes support bracket)	500mm	720643001
B Flue Extension (includes support bracket)	250mm	720643101
C Flue Bend (In Line)	93°	720648401
C2 Offset Elbow-for boiler only (Duo-tec 2, Duo-tec ErP, Megafluo 2 32, Megafluo ErP, EcoBlue Advance Combi, EcoBlue System 32, Platinum ErP & Promax ErP)	93°	720635501
D Flue Bend	135°	720648501
D Flue Bend (pair)	135°	720647901
U Flue Support Bracket	100mmØ	5111080
R Vertical Flue Adaptor 60/100 to 80/125		5111070
(use with 5111078)		
S Flue Terminal Deflector (Black)		5111068
S Flue Terminal Deflector (White)		720644201
S Flue Terminal Deflector (Brown)		720644301
MISCELLANEOUS		
Z Single Terminal 80mm (air inlet only)		5121791
Z1 60 - 80 Adaptor - Twin Flue		5121792
Z2 Pitched Roof Terminal-Twin Flue (Z1 req'd) (Black)		720576301
Z4 PDK - (Black)		720622901
Z4 PDK - (White)		720627001

Key Accessory	Size	Code No
FLUE GROUP G		
Flue System 80/125mm diameter		
A4 Horizontal Flue Kit	685mm	5118580
B Flue Extension Kit	1000mm	5118584
D Bend (pair)	135°	5118597
C Bend	91.5°	5118588
U Flue Support Bracket	125mmØ	5118610
FLUE GROUP N		
Twin Flue System 80mm diameter		
E Flue Extension (pair, includes 2 brackets)	1000mm	5111087
F Flue Bend (pair)	90°	5111072
G Flue Bend (2 pair)	135°	5111086
J Vertical Flue Boiler Adaptor Kit		720089801
H Vertical Flue Adaptor		5111084
Y Twin Flue Terminal (Horizontal Termination)		5120172
W Flue Support Bracket (pair)	80mmØ	5111081
FLUE GROUP A, N, G		
Vertical Flue Kits		
K Vertical Flue Terminal 60/100		5118576
KI Vertical Flue Terminal 80/125 (Black) (use with 5111070)		5111078
L Pitch Roof Flashing (Black)	25°/50°	5122151
M Roof Cover Plate		246143
N Flat Roof Flashing (Black/Grey)		246144

CONCENTRIC FLUE SYSTEM (60/100) ONLY - FLUE GROUP A

USE OF SUPPORTS & SECURING

Each extension and securing screws (1m, 500mm & 250mm) is supplied with a support bracket. Additional support brackets can be purchased separately (see Flue Accessory page overleaf). **DO NOT** use brackets other than those supplied or shown in this guide.

The flue system **MUST** be supported **AT LEAST** once every metre of actual length, and every straight length should be supported with a bracket.

The bracket should be positioned as close to the female end of the extension providing that the surface the bracket is to be fixed to is sound. **DO NOT** position the bracket over the swaged part of the extension or the rivets.

Also provided with each extension and elbow are two special self drilling screws. These **MUST** be used to secure the female air duct to the male duct of the next extension or elbow (in exceptional circumstances where access is limited one screw will suffice).

CUTTING EXTENSIONS

Where it is necessary to reduce the length of an extension, both exhaust and air duct **MUST** be cut square and flush, and any burrs removed to avoid damage to the flue seal on both exhaust and air duct on assembly.

It is recommended that tape is used as a guide to first cut around the air duct and then the exhaust duct be cut square and flush with the air duct.

The spring support should be positioned approximately 100mm from the male end of the extension to maintain concentricity.

ASSEMBLING

Both ducts of the elbow or extension are fitted with an inner lip seal. It is important that the seals are lubricated as follows:-

Use suitable gloves - open the sachet of grease supplied and apply grease sparingly to the inner seal of both air and exhaust ducts to aid assembly.

Wipe away any excess grease prior to assembly. Avoid contact with eyes after handling the grease, and thoroughly wash hands.

Engage the male end of the extension or elbow into the female of the next extension or elbow. Ensure that it is fully inserted to achieve the required penetration depth. The extension have been designed to maintain an expansion gap for the exhaust duct.

Using the special self drilling screws supplied secure the air duct to the next extension or elbow. The screws must be inserted via the holes in the female end of the air duct or through the indentations on elbows/bends. **NOTE:** No drilling is required - the screw will pierce the male end of the extension or elbow.

Identify the positions of the support brackets and mark the wall or surface on which they will be mounted. Drill and plug as required.

If necessary shorten the threaded rod. Fix the support bracket to the wall. Locate the tongue of the outer bracket half in the slot of the inner half. When all brackets are in place offer the flue up to them, and secure the two halves of the brackets with the screw. If the rods are not long enough it may be necessary to erect a spacer or structure to adequately support flue system brackets. **It is not recommended to use longer threaded rods.**

IMPORTANT: Mounting and securing the flue will be easier if performed by two people! When the flue system is in place fully tighten all brackets systematically, ensuring that no parts are under any strain or tension and no dips where condensate can pool.

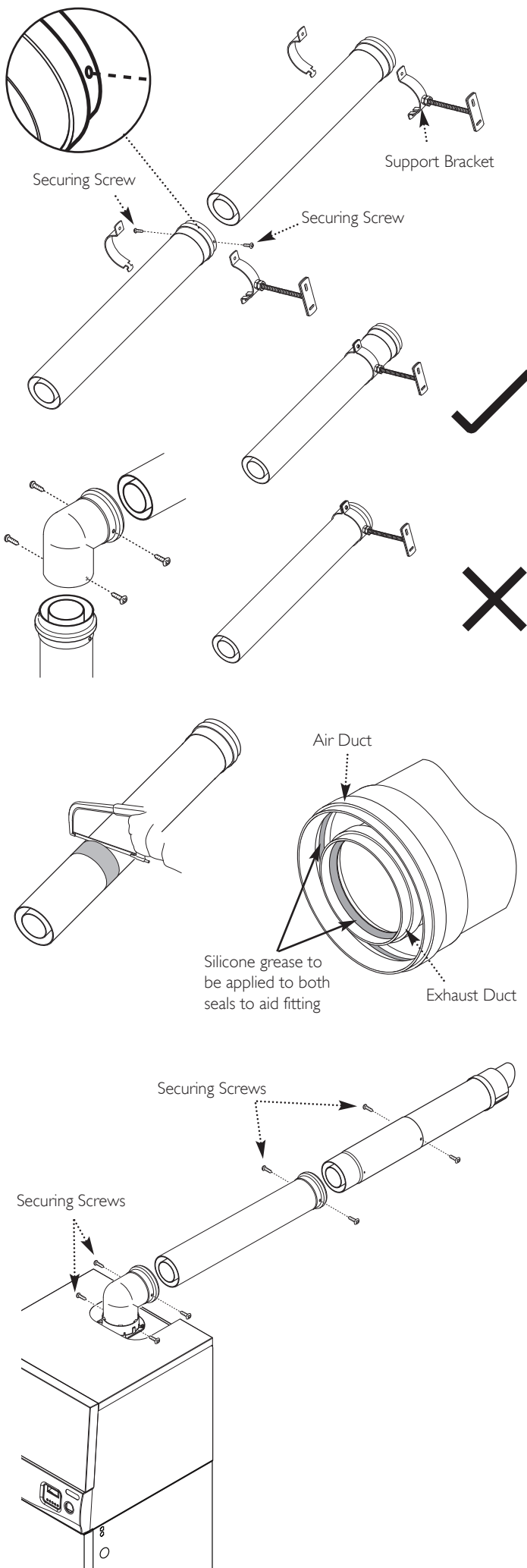

FLUE OPTIONS

Horizontal Flue System Examples

NOTE: Horizontal flue pipes should always be installed with a 1.5° to 3° fall from the terminal to allow condensate to run back to the boiler.

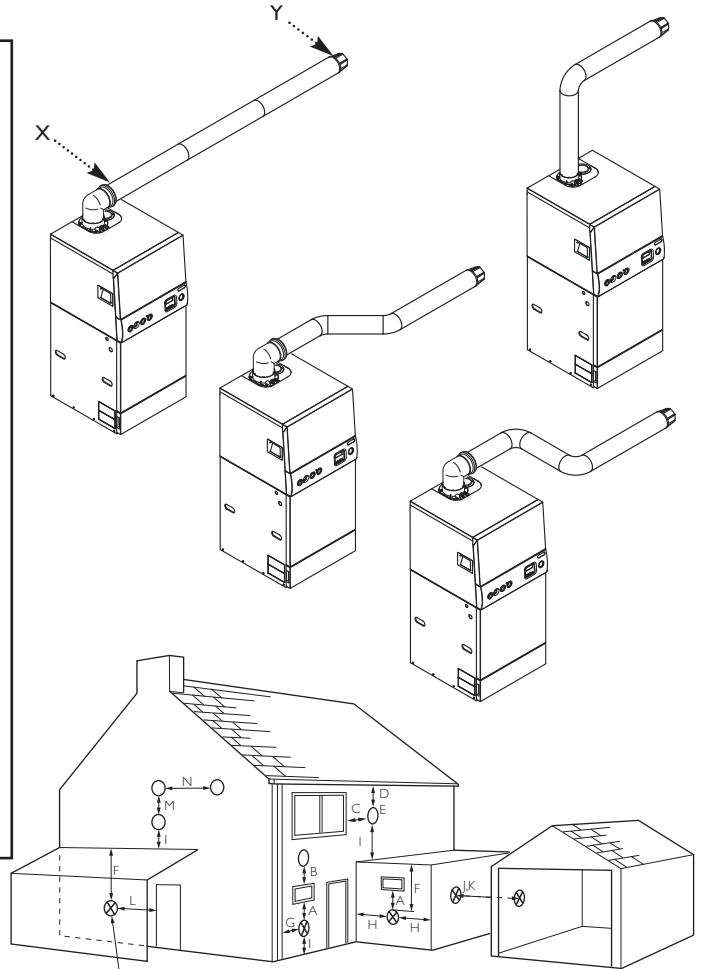
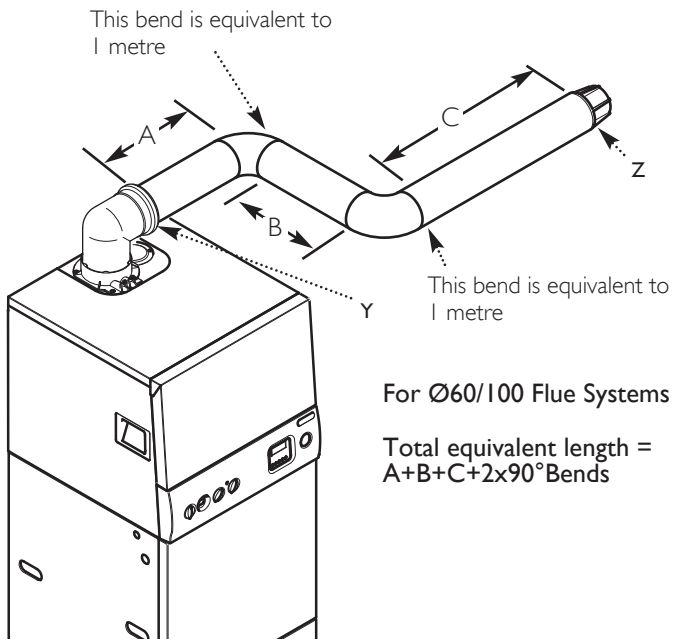

Terminal Position with Minimum Distance (mm)

A ¹	Directly below an opening, air brick, opening windows, etc.	300
B ¹	Above an opening, air brick, opening window etc.	300
C ¹	Horizontally to an opening, air brick, opening window etc.	300
D ²	Below gutters, soil pipes or drain pipes.	25
E ²	Below eaves.	25
F ²	Below balconies or car port roof.	25
G ²	From a vertical drain pipe or soil pipe.	25
H ²	From an internal or external corner.	25
I	Above ground, roof or balcony level.	300
J	From a surface or boundary line facing a terminal.	600
K	From a terminal facing a terminal (Horizontal flue). From a terminal facing a terminal (Vertical flue).	1200 600
L	From an opening in carport (e.g. door; window) into the dwelling.	1200

¹ In addition, the terminal should be no nearer than 150 mm to an opening in the building fabric formed for the purpose of accommodating a built-in element such as a window frame.

² Only **ONE** 25mm clearance is allowed per installation. If one of the dimensions D, E, F, G or H is 25mm then the remainder **MUST** be as B.S.5440-1.

NOTE: The distance from a fanned draught appliance terminal installed parallel to a boundary may not be less than 300mm in accordance with the diagram below

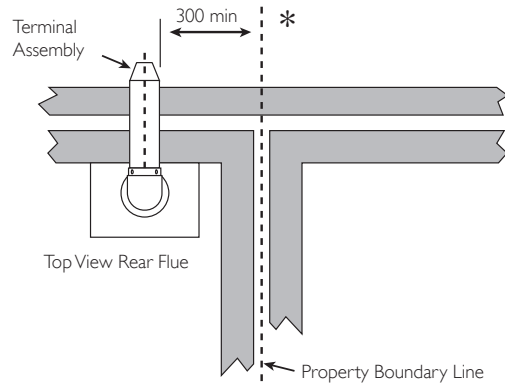

* Reduction to the boundary is possible down to 25mm but flue deflector part no. 5111068 must be used.

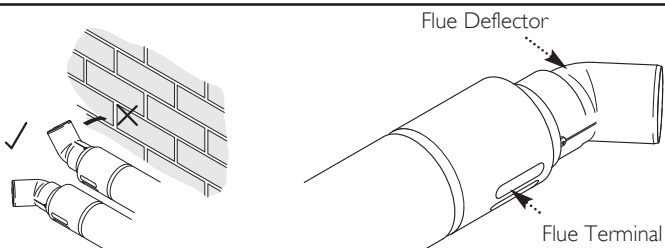

DO NOT DIRECT THE FLUE DEFLECTOR TOWARDS A WALL.

Push the flue deflector over the terminal end and rotate to the optimum angle for deflecting plume. Secure the deflector to the terminal with screw provided. Do not direct the deflector upwards or downwards.

NOTE: A terminal guard is still required when circumstances dictate (B.S. 5440-1).

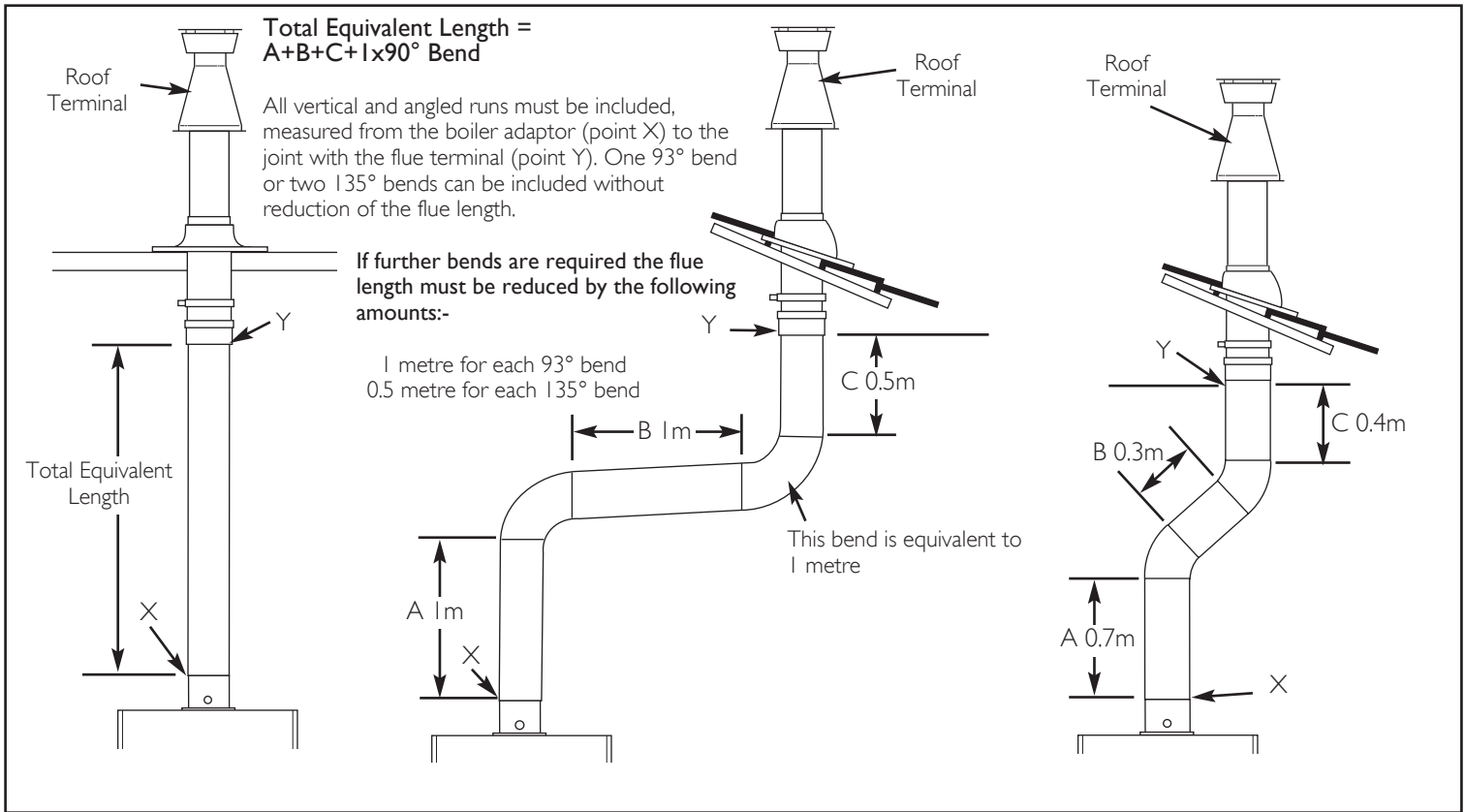

CONCENTRIC FLUE		
Equivalent Length Value	N° of fittings/pipes	Sub total
Actual Length	3 (A+B+C)	2.5m
135° bend	0	0
93° bend	2*	1m
Equivalent Flue Length = 3.5m		

extensions
135° bend
93° bend

*1 x 93° bends are allowed without affecting the calculation

CONCENTRIC FLUE		
Equivalent Length Value	N° of fittings/pipes	Sub total
Actual Length	3 (A+B+C)	1.4m
135° bend	2*	0
93° bend	0	0
Equivalent Flue Length = 1.4m		

extensions
135° bend
93° bend

*Up to 2 x 135° bends are allowed without affecting the calculation

For Use With Flue Group **G** Ø80/125 Flue Systems

Ø80/125 FLUE SYSTEMS

The adaptor shown is available separately for vertical flue applications. (It is included with the 80/125 Horizontal Flue Kit).

Apply lubrication and ensure that the 80/125 adaptor is fully engaged in the boiler adaptor.

Secure with the screws supplied with boiler.

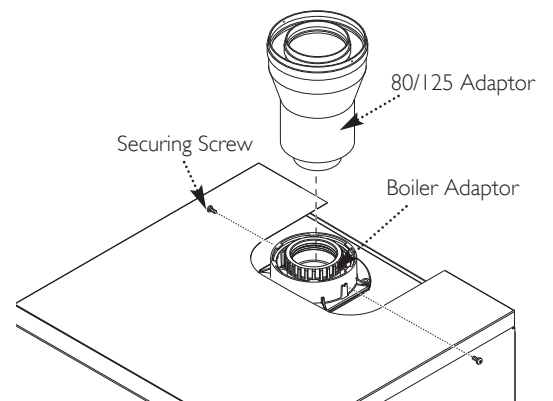
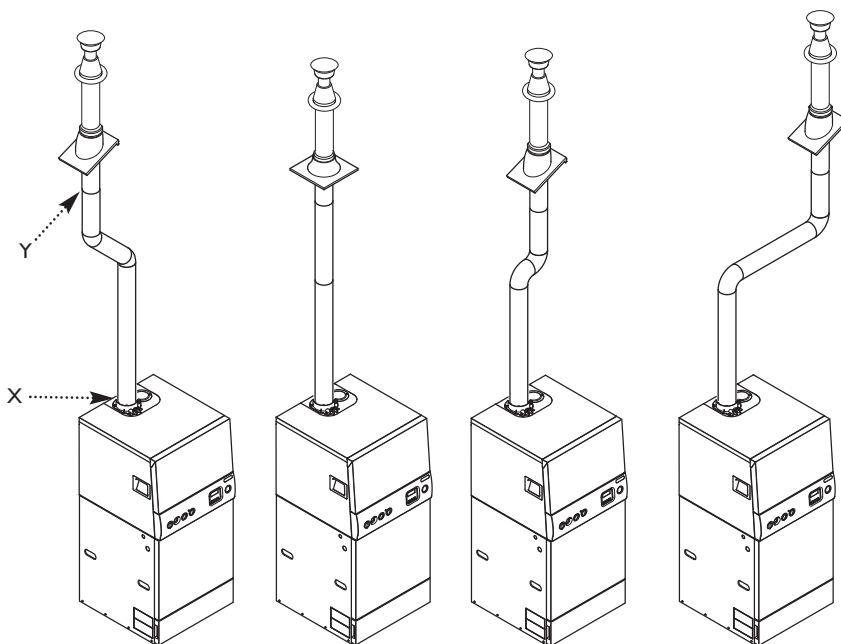

FLUE OPTIONS

Twin Pipe Flue System Examples

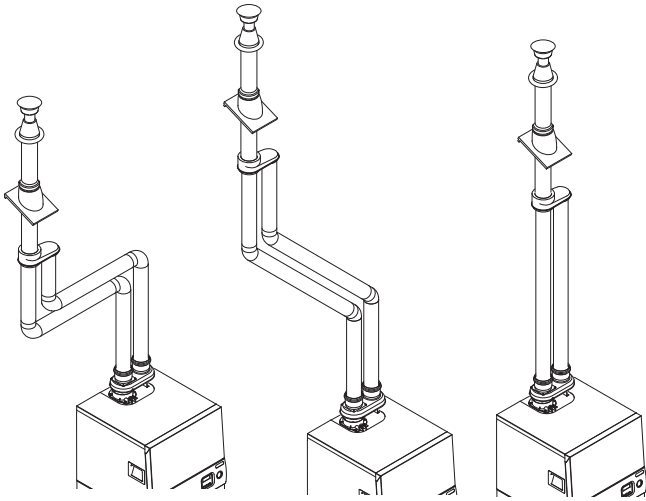

Terminal Position - Separate Twin

- Both terminals must be on the same wall. It is also permissible to situate the air inlet terminal in a ventilated uninhabited void or compartment (e.g. loft space)
- The terminals must not be closer than 120mm when measured between the centrelines (Fig. A).
- If this distance is up to 300mm the flue outlet duct must protrude 200mm from the wall face. The air inlet must protrude 60mm (Fig. A).
- When the distance between centrelines is greater than 300mm the flue outlet duct must protrude 100mm and the air inlet 60mm (Fig. B).
- When the air inlet terminal is situated in a ventilated uninhabited void or compartment there must be at least 300mm from the floor of this space to the terminal. No obstructions must be placed within a 300mm radius of the terminal.

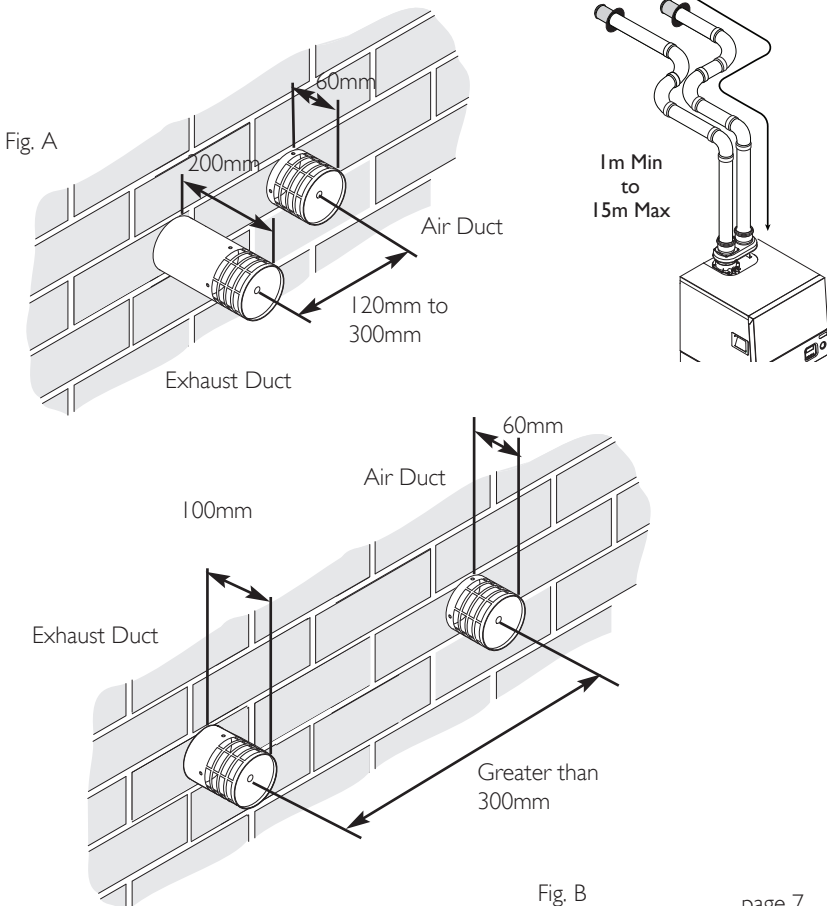

The total equivalent length for this example is = 6.5 metres.

AIR DUCT		
Equivalent Length Value	N° of fittings/pipes	Sub total
1m extension	5	5.0m
135°bend	2	0.5m
91.5°bend	2	1.0m
Equivalent Length Air Duct = 6.5m		

EXHAUST DUCT		
Equivalent Length Value	N° of fittings/pipes	Sub total
1m extension	5	5.0m
135°bend	2	0.5m
91.5°bend	2	1.0m
Equivalent Length Exhaust Duct = 6.5m		

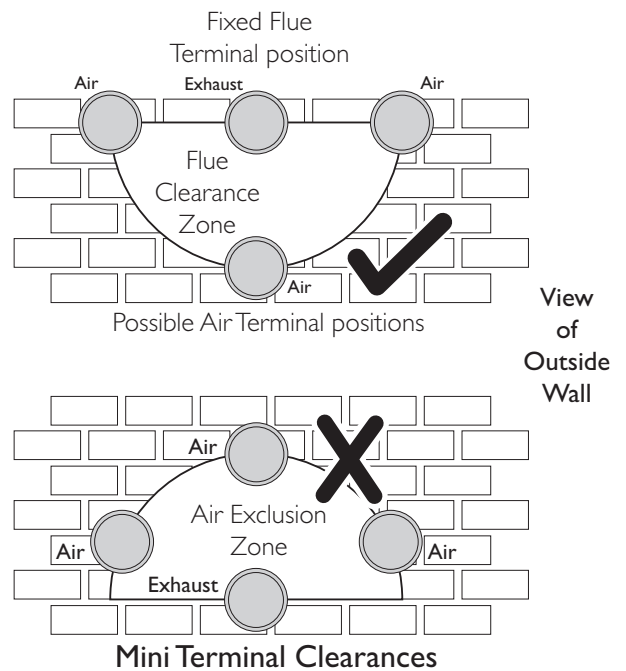

FITTING THE ADAPTOR

For Use With Flue Group **N**
Ø80/80 Twin Flue Systems

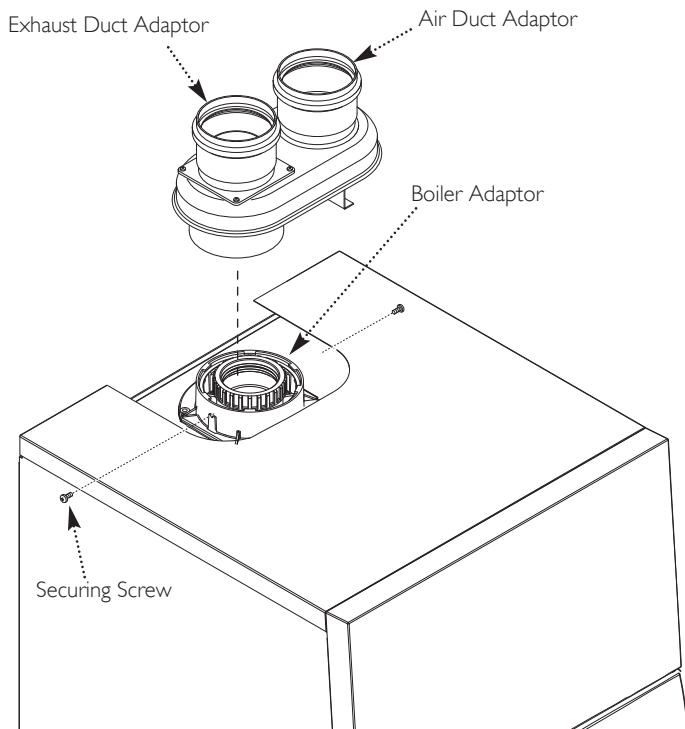

Twin Pipe Flue System (80/80)

The kit allows connection of a twin flue system to the boiler adaptor.

Engage the twin flue duct adaptor in the boiler adaptor, making sure that it is pushed down as far as possible.

Ensure that the air & flue ducts are connected correctly and that they are adequately supported (at least once every metre using the brackets supplied).

Cut the extensions to length if required (cut at the MALE end!), ensuring that they are square and free from burrs.

USE OF SUPPORTS & SECURING

The flue system **MUST** be supported **AT LEAST** once every metre of actual length, and every straight length should be supported with the bracket supplied.

Additional support brackets may be purchased separately. **DO NOT** use brackets other than those supplied or shown in this guide.

The support bracket must be positioned on the main length of the pipe.

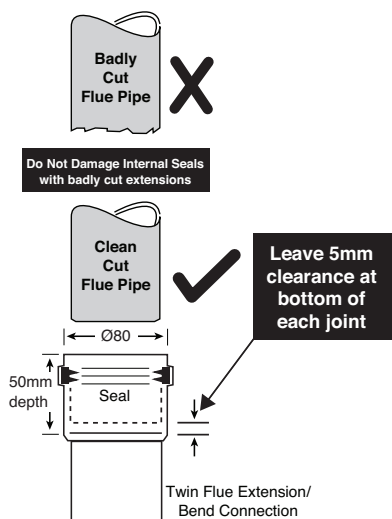

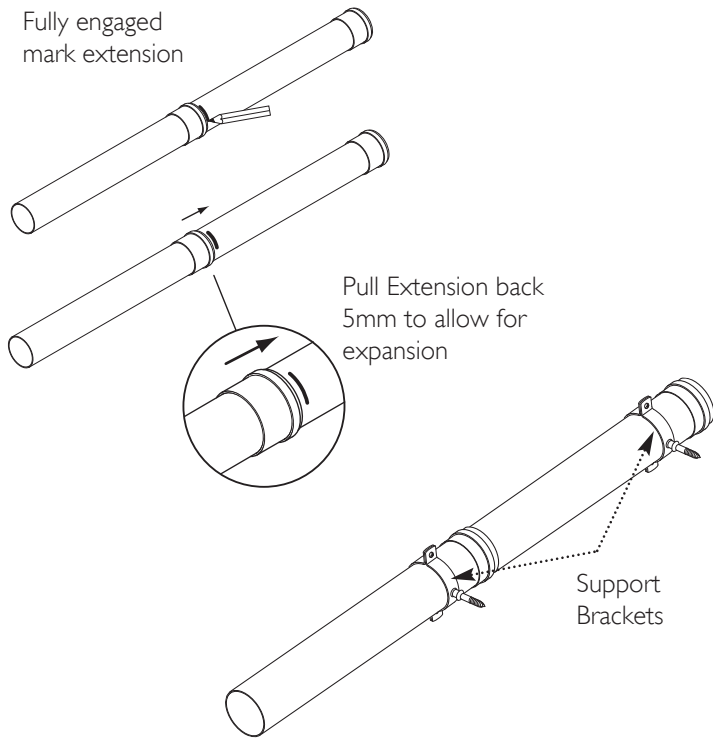

ASSEMBLING

Engage the male end of the extension or elbow into the female of the next extension or elbow. Ensure that it is inserted as shown opposite to allow for expansion & contraction.

Identify the positions of the support clamps and mark the wall or surface on which they will be mounted. Drill and plug as required.

When all brackets are in place offer the flue up to them, and secure the two halves of the bracket with the screw.

IMPORTANT: Mounting and securing the flue will be easier if performed by two people !

When the flue system is in place fully tighten all brackets systematically, ensuring that no parts are under any strain or tension.

TWIN PIPE SYSTEM - AIR INLET IN LOFT SPACE VENTILATION & CLEARANCE

The air duct inlet terminal must be positioned in a suitably ventilated loft space or compartment. The loft space or compartment must not be a habitable room, and must be ventilated **ONLY** to outside air.

The ventilation provided must be **PERMANENT** and not subject to inadvertent blockage.

The loft space or compartment must be isolated from any habitable area.

There must be a minimum of 300mm from the loft space or compartment floor to the lower edge of the air inlet grille to prevent accidental blockage. No obstruction must be placed horizontally within 300mm of the air inlet.

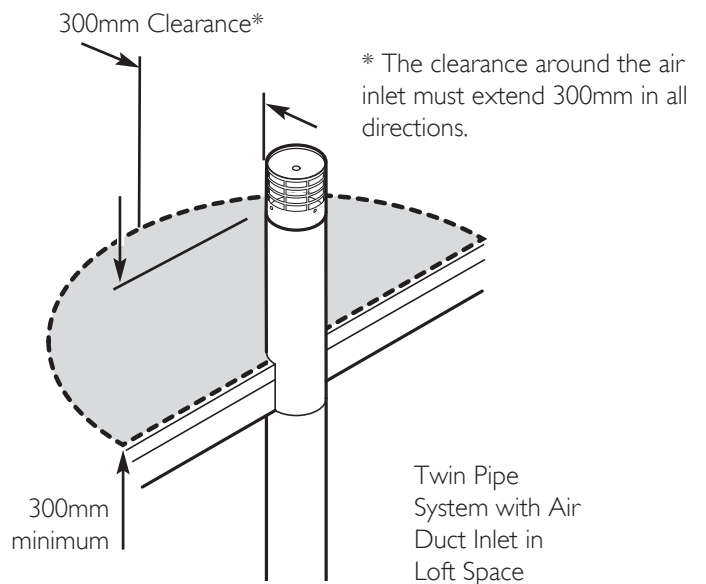
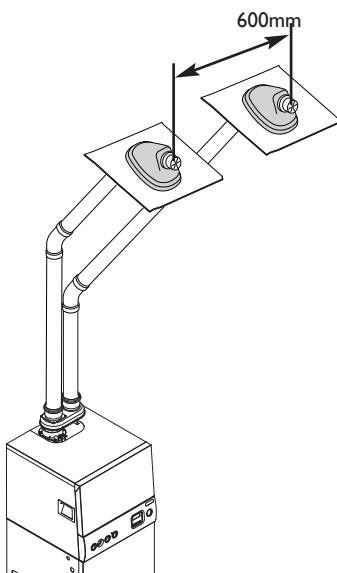
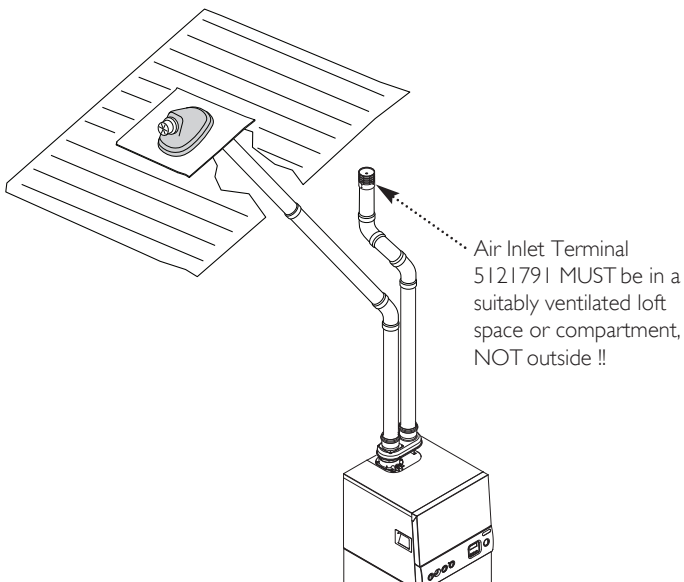

FITTING THE ROOF TERMINAL

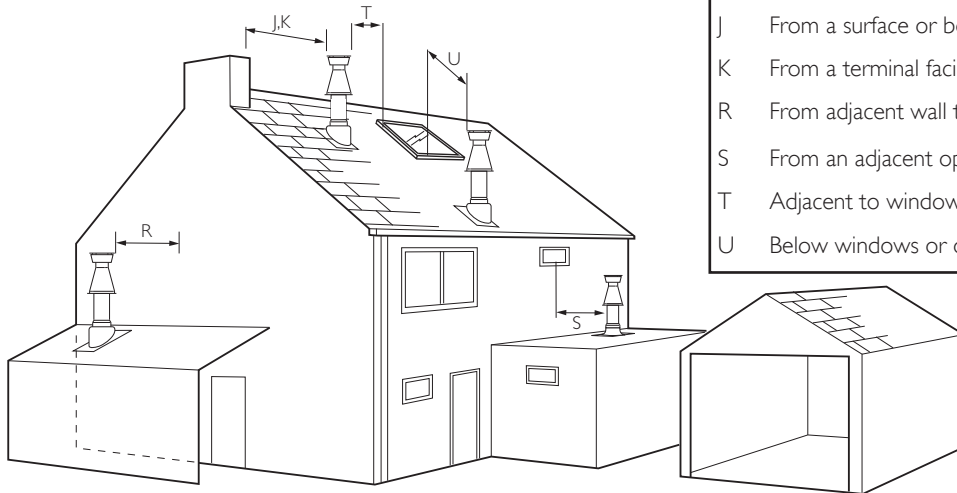

Special Requirements for Vertical Balanced Flue		
	POSITION SPACING	MIN
J	From a surface or boundary line facing a terminal	600mm
K	From a terminal facing a terminal	600mm
R	From adjacent wall to flue	300mm
S	From an adjacent opening window	1000mm
T	Adjacent to windows or openings on pitched roofs	600mm
U	Below windows or openings on pitched roofs	2000mm

Fitting the Roof Terminal to the Flashing:

Ensure the roof terminal collar is correctly seated onto the flashing spigot to prevent leakage.

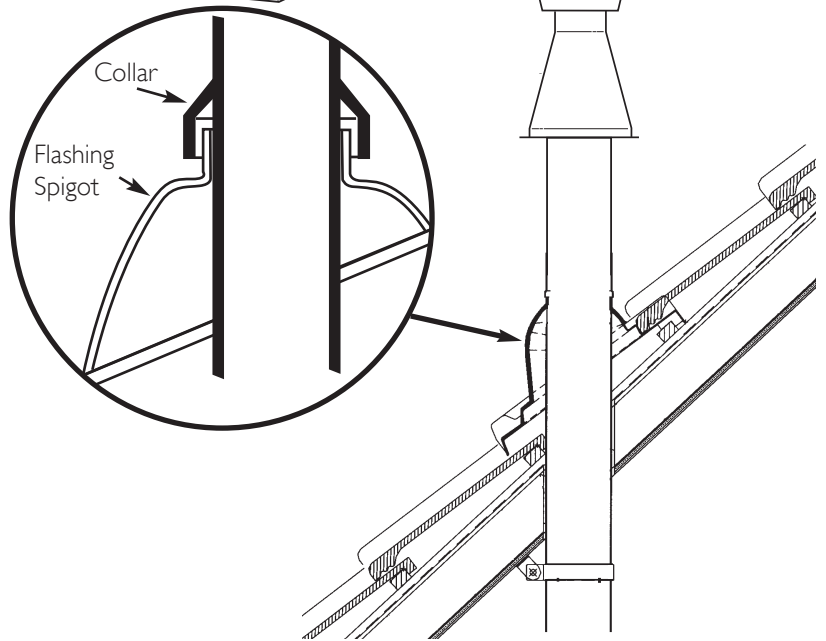

It is necessary to cut the flue terminal air duct by 170mm. Dimensions x & y must be 60mm.

For Roof Terminals

1. In the case of a pitched roof 25 - 50 degrees, position the lead tile to replace/flash over existing roof tiling. Make an aperture in the roof suitable for the lower tube of the roof terminal and ensure the integrity of the roof cover is maintained. The adjustable plastic collar can either be positioned on the lead tile or the lower tube of the roof terminal prior to the final positioning of the vertical flue through the tile. Check the collar is correctly located to suit required roof pitch (either 25° to 38° or 37° to 50°). From inside the roof adjust the flue to a vertical position and secure to the roof structure with the clamp supplied.

2. For flat roof installations the aluminium flashing must be incorporated into the roof covering and the appropriate aperture made in the roof decking. The vertical flue is lowered onto the flashing making sure the collar of the flue locates securely with the flashing. (A mastic seal may be necessary). From inside the roof, adjust the flue to a vertical position and secure to the roof structure with the clamp supplied.

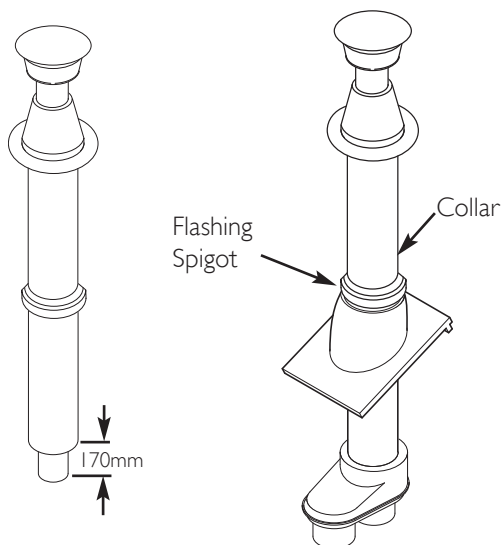

Cut air duct to leave 170mm of exhaust duct protruding

IMPORTANT: If the boiler is not fitted immediately after the flue system, temporary precautions must be taken to prevent rain entry into the room of installation. Any precautionary measures must be removed prior to commissioning the boiler.

PLUME DISPLACEMENT ACCESSORIES

Key Accessory	Size	Code No
Plume Displacement - Black - 60/100mm diameter		
A Plume Displacement Kit (Black) (includes terminal assembly, 1000mm extension, outlet elbow and 2 support brackets)	Ø100	720622901
B Exhaust PDK Extension (Black - inc. Brackets)	1000mm	720643301
C PDK Bend (Black)	93°	720648701
D PDK Bend (Black) (Pair)	135°	720648601
E Support Bracket (Black)	Ø60	720623301

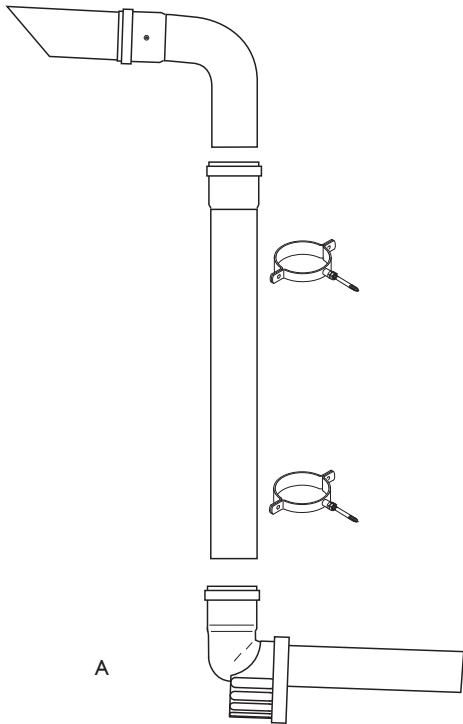

Key Accessory	Size	Code No
Plume Displacement - White - 60/100mm diameter		
A Plume Displacement Kit (White) (includes terminal assembly, 1000mm extension, outlet elbow and 2 support brackets)	Ø100	720627001
B Exhaust PDK Extension (White - inc. Brackets)	1000mm	720643401
C Plume Bend (White)	93°	5121369
D Plume Bend (White) (Pair)	135°	5121370
E Support Bracket (White)	Ø60	720627801

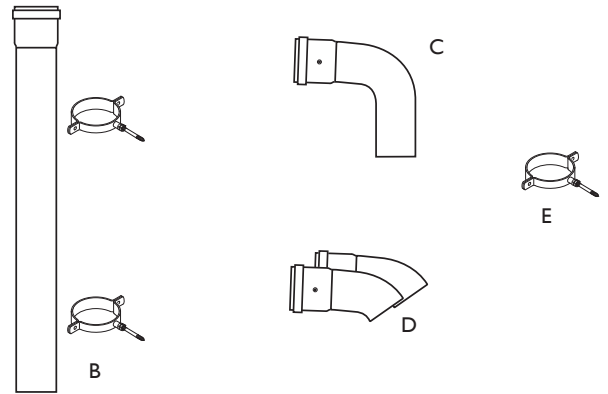

FITTING PLUME DISPLACEMENT KIT

The Plume Displacement Kit replaces the terminal assembly of the standard telescopic flue kit (720598701, 720642701, 720599401 & 720870201 only).

The kit may be employed either at the time of fitting the boiler, or retrospectively if the circumstances of the installation change such that flue position no longer meets regulations, e.g. the building of an extension adjacent to the flue terminal or other obstructions.

Remove the screws securing the standard terminal assembly and withdraw it from the air duct. Discard the terminal and screws.

Take the PDK terminal assembly and insert it into the telescopic flue. Secure using the new screws provided with the PDK.

New installations - fit the telescopic flue with the PDK terminal to the boiler and make good the wall.

Cut the 1000mm extension to length if required, ensuring that the end is square and free of burrs.

Determine the position of the support clamps and drill and plug the wall. Fit the extension to the terminal and fix the clamps to the wall.

Tighten the clamps and fit the outlet elbow to the female end of the extension. The outlet should be perpendicular to the wall (i.e. 90°) but may be angled to either side by no more than 45°.

Important Note - When fitting PDK retrospectively:-

If screws and tape have been used to secure the flue system air ducts and boiler elbow together originally, installation should be straightforward. However, if any movement of the flue system inside the dwelling is suspected, the integrity of flue should be checked by performing a flue gas analysis at the boiler adaptor air sampling point.

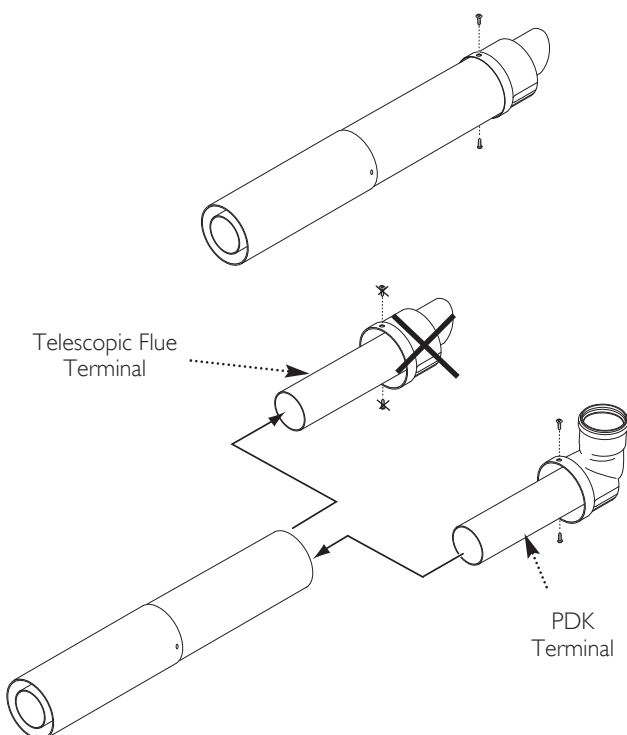

FITTING PLUME DISPLACEMENT KIT

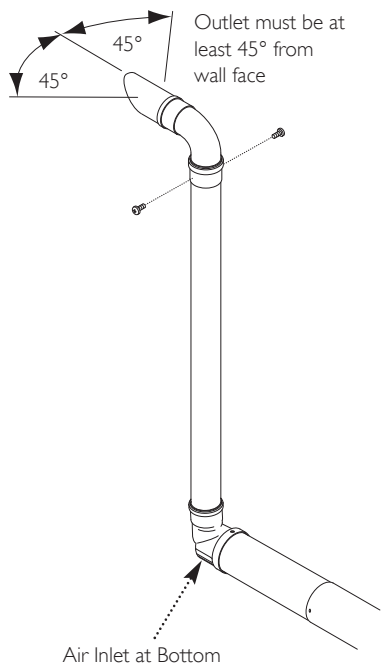

The outlet of the PDK MUST be at least 2 metres above ground or balcony level. If necessary additional 60Ø extensions should be used to achieve this.

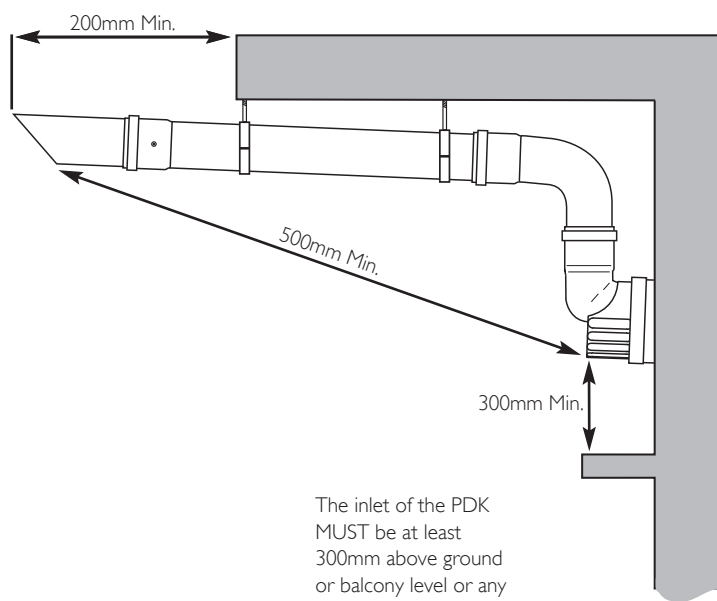
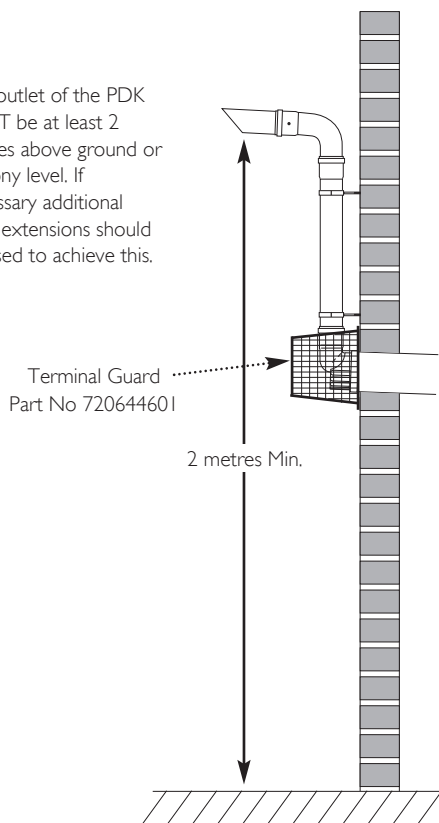

The inlet of the PDK MUST be at least 300mm above ground or balcony level or any projection or ledge. A guard must be fitted where the inlet is below 2 metres.

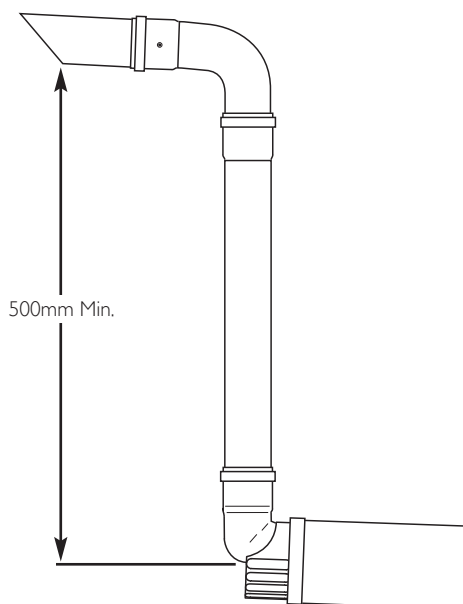

DETERMINING PERMISSIBLE LENGTHS - P.D.K.

In the graph the solid line diagonal represents the relationship between the concentric flue assembly (and any extensions) and the 60Ø exhaust (and any extensions or additional bends).

Example 1 - Not Permissible

If, for instance, a concentric length of 5 metres was required and the 60Ø exhaust needed to be 11 metres the graph shows that this combination would NOT be permissible as the intersection point would be above both solid diagonal lines A & B.

Example 2 - Flue Lengths OK

Where both lengths have been determined they can be applied to the graph to check that the installation is permissible. For example, if it was known that 2 metres of concentric flue and 4 metres of 60Ø exhaust were required, the values could be applied to the graph as shown in Example 2. As the point of intersection of the dotted lines is below both solid diagonal lines, the combination of lengths is shown to be acceptable.

Example 3 - Flue Lengths OK

In the example shown, assume that the concentric part of the flue needs to be 2 metres long. Find the position of '2' on the horizontal axis of the graph and then project upwards to the solid diagonal line. This is represented by the vertical thick dotted line. Where this dotted line intersects with the solid diagonal line on the graph, project across to the vertical axis. As can be seen this corresponds with 6 metres (line B). Therefore, the total equivalent length of the 60Ø exhaust can be up to 6 metres (models in group B below). Any bend equivalencies must be accounted for i.e. 93° bends are equal to 1 metre, each 45° bend to 0.5 metres.

Graph Line A is suitable for:-

Promax Store ErP Model

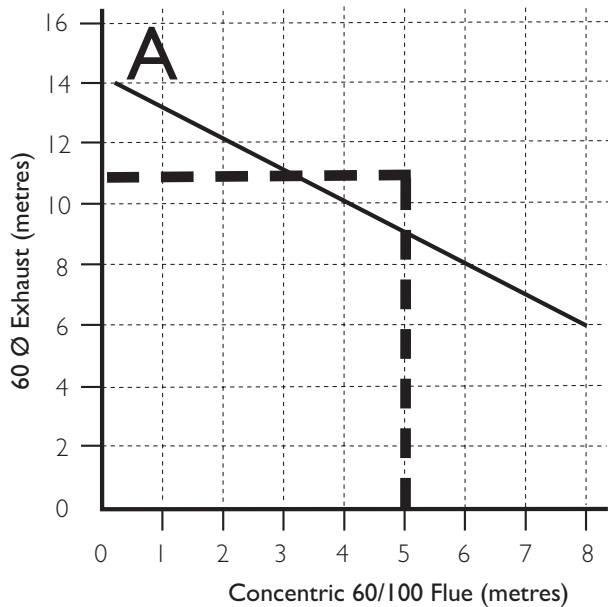

Example 1:- Flue Length - Not Permissible

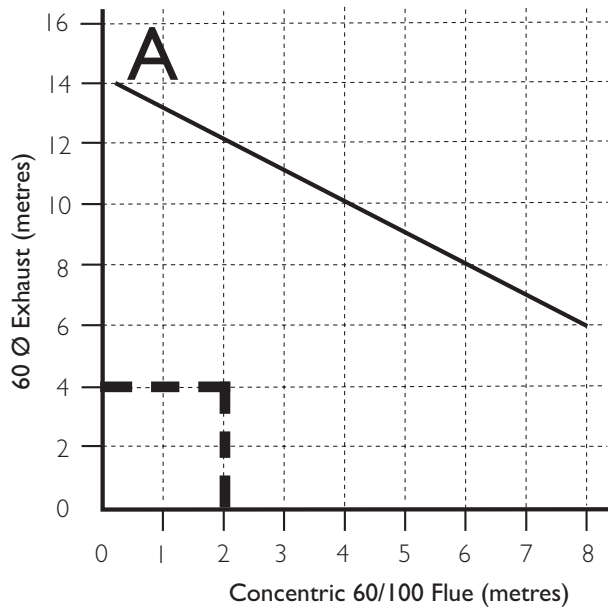

Example 2:- Flue Length - OK

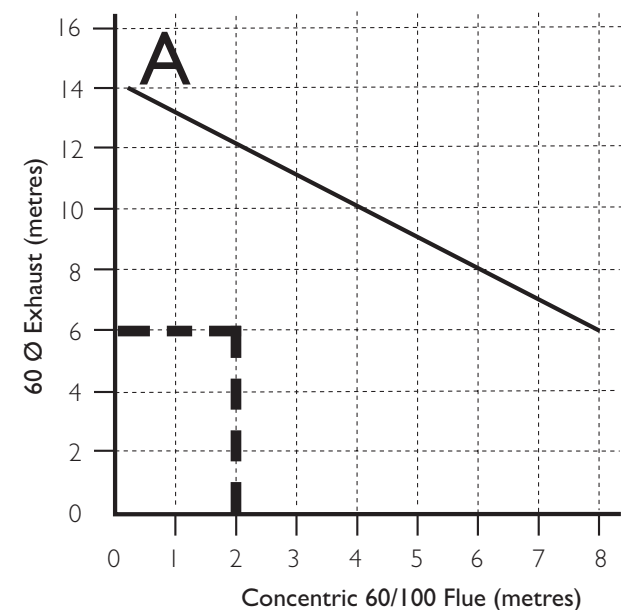

Example 3:- Flue Length - OK

TERMINAL EXTENSION (UNDER BALCONIES & EAVES)

Chimney Exhaust Extension - Description

The kit may be employed either at the time of fitting the boiler, or retrospectively if the circumstances of the installation change such that terminal position no longer meets regulations, e.g. the building of an extension adjacent to the terminal or other obstructions.

The extension terminal must protrude at least 200mm beyond the structure. It is particularly recommended for installations where the chimney system terminal is under a balcony, soffit or similar projection.

NOTE: Due to the nature of the boiler a plume of water vapour will be discharged from the flue. This should be taken into account when siting the terminal to avoid any potential nuisance.

IMPORTANT: The equivalent length of the existing concentric chimney **MUST** be considered before fitting this kit to ensure that the maximum equivalent length is not exceeded as the terminal supplied has an a equivalency factor of 3 metres. The extension must fall 2° to 3° back to the boiler.

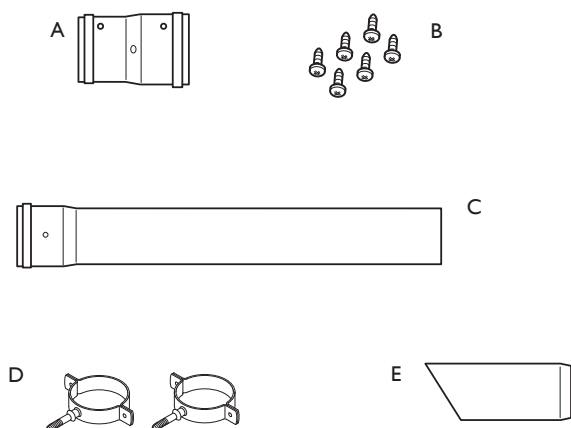

The kit comprises:-

- A - 1 x adaptor assembly
- B - 6 x adaptor/terminal fixing screws
- C - 1 x straight length of exhaust (1 metre)
- D - 2 x support brackets
- E - 1 x extension terminal

Additional 1 metre straight lengths are available, but **MUST NOT** be fitted if doing so would exceed the maximum permissible equivalent length of the chimney system as detailed in the boiler instructions.

**IT IS NOT PERMISSIBLE TO INCLUDE BENDS
IN THE EXTENSION !**

Equivalent lengths

Extension Terminal - 3 metres*

Straight Length - as measured (e.g. 0.5 m = 0.5 m)

*This **MUST** be included in ALL calculations when fitting this kit !

Chimney Exhaust Extension - Installation

Locate the larger diameter of the adaptor over the existing terminal and secure with two of the screws supplied.

Establish the path the exhaust extension will take and ensure that adjacent surfaces are sound enough on which to mount the support brackets. Determine the position of the brackets and drill and plug the surface.

Where additional lengths are used it may be necessary to secure spacer blocks on the fixing surface on which to mount the support brackets

Remove the saddle clamps from the support brackets. Locate the wall studs on the brackets in the previously plugged holes and tighten.

Insert the terminal supplied into the extension. Mark 30mm from the end of the extension, and drill two holes \varnothing 4mm through the extension and terminal. Secure using two of the screws supplied.

Fit the assembled extension to the adaptor with the remaining screws and fix the saddle clamps to the support brackets. Adjust the brackets to ensure the extension falls at 2° to 3° back to the boiler.

Check & ensure the following:-

- All lip seals are in place and correctly fitted in the location groove of the female socket.
- Extensions are cut square and any burrs removed before assembly.
- Apply a thin film of the silicone grease supplied to all seals and male parts of components.

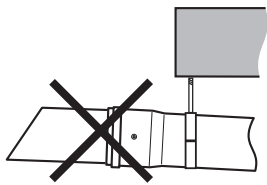
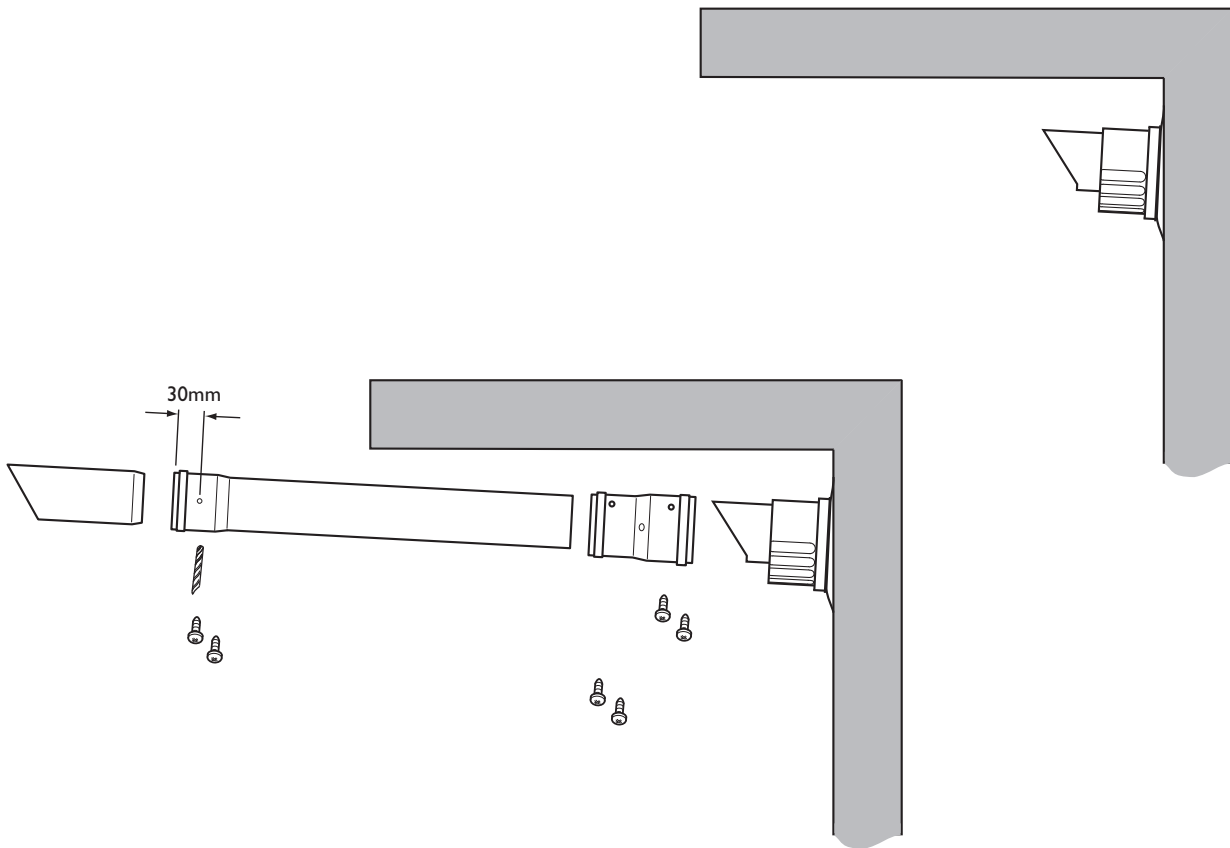

The terminal **MUST NOT** be fitted in this orientation !
 Ensure that the “peak” of the terminal is uppermost.

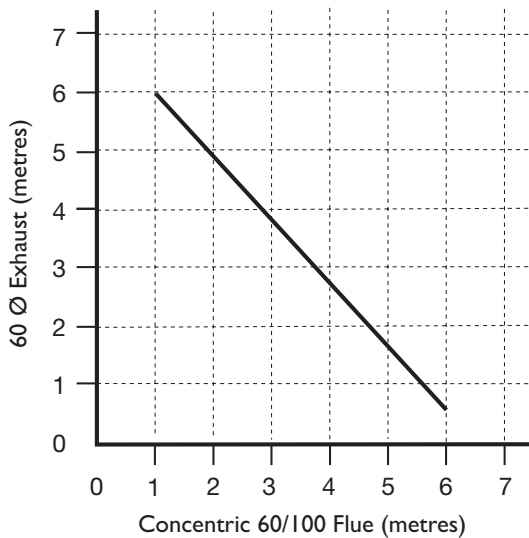
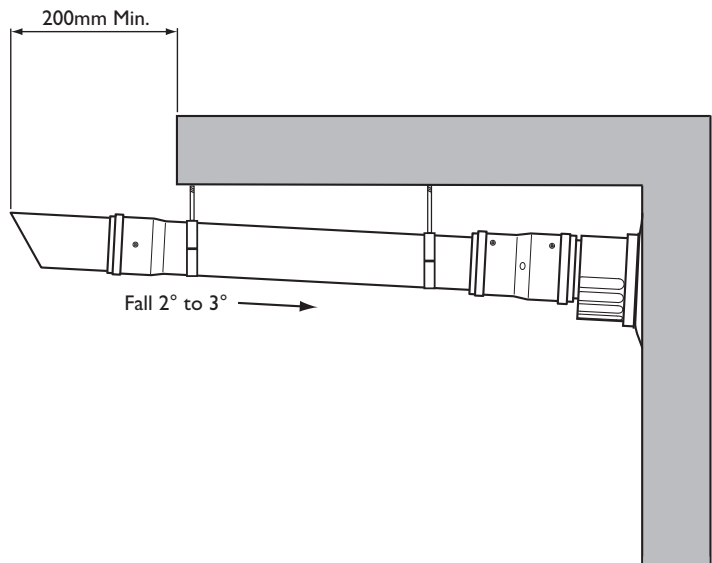

All descriptions and illustrations provided in this leaflet have been carefully prepared but we reserve the right to make changes and improvements in our products which may affect the accuracy of the information contained in this leaflet. All goods are sold subject to our standard Conditions of Sale which are available on request.

MULTIFIT

A Registered Trademark of Baxi Heating UK Ltd (3879156)
Brooks House, Coventry Road, Warwick. CV34 4LL
Technical Enquiries 0844 871 1555
Website: www.baxi.co.uk

e&oe

PART OF BDR THERMEA

7223262 - 01 (4/15)