

GAS 310/610 ECO PRO



 remeha

ENGINEERING EFFICIENCY SINCE 1935

WHAT'S INSIDE

- 03 WELCOME TO REMEHA
- 03 INTRODUCING THE REMEHA
GAS 310/610 ECO PRO RANGE
- 04 TYPICAL BOILER
CONSTRUCTION
- 07 OPERATING PRINCIPLE
- 08 TECHNICAL INFORMATION
- 12 ENGINEERING SPECIFICATION
- 14 BOILER DIMENSIONS
- 19 SPACE SAVING
CONFIGURATIONS
- 20 MAINTENANCE AREAS
- 22 TYPICAL INSTALLATION
- 23 ELECTRICAL CONNECTIONS
AND CONTROLS
- 24 WIRING LAYOUT
- 25 SAFETY INTERLOCKS
- 26 BOILER CONTROLS
- 28 FLUE DATA
- 31 TECHNICAL SUPPORT
- 31 DECLARATION OF COMPLIANCE

WELCOME TO REMEHA, THE EXPERT CHOICE

WE LEAD THE WAY IN INNOVATION, RELIABILITY AND EFFICIENCY
FOR ADVANCED COMMERCIAL HEATING SOLUTIONS.

We're completely focused on commercial heating solutions and are at the forefront of condensing gas boiler technology – we don't manufacture boilers for anyone else.

We invest heavily in research and development which enables our specialist teams to design high performance products at every level. From using the latest materials and manufacturing techniques to meticulously designing and engineering each boiler, we ensure they're efficient to specify, install, run and maintain.

All our boilers share the same simple design – so they're expandable, adaptable and future-proofed.

We've tried to think of everything, so from specification to blueprint sign-off through to supply and installation, our customer service and product support is our number one priority.

INTRODUCING THE REMEHA GAS 310/610 ECO PRO RANGE

The Gas 310/610 Eco Pro range features compact, floor-standing, gas-fired, high efficiency condensing boilers (available in five to ten section models from 285 to 1300 kW).

Their small footprint and ability to be installed side-to-side makes them ideally suited for modular configuration while the secondary return feature makes this boiler suitable for use with both CT and VT circuits. An optional optimising weather compensating control package can also ensure maximum efficiency.

These boilers are suitable for both new and retrofit applications. With conventional and room-sealed capability, they can be installed in most situations.



FEATURES AND BENEFITS

Integral flue gas non-return valve	Multiple flues can use the same riser without risk of cross contamination
High efficiency boiler-up to 96.64% GCV	Higher than average energy-savings
Compact, lightweight construction	Easy to install in smaller spaces; particularly suitable for retrofit applications
Easy disassembly/reassembly and has integrated wheels	Improved ease of installation especially where access is restricted
Ultra-low Class 5 NO_x emission levels of 36mg/kWh 0% O₂ dry and under	Low pollutant emissions that meet environmental regulations including BREEAM, and Clean Air Act
Pre-mix down-firing gas burner, one-piece cast aluminium heat exchanger with ultra-low NO_x emissions	Clean, trouble-free operation and optimum combustion
Digital diagnostic display and remote signalling options	Easy maintenance
Remeha's boiler control includes: • modulating 18-100% • compatible with OT Open Therm • 0-10V or volt free	Built-in flexibility for easy installation and efficient, reliable heat delivery
Optional secondary return kit	For use with both CT and VT circuits
Quiet operation ≤68 dB(A)	Improved comfort
Left or right hand version (Gas 310 Eco Pro)	Greater flexibility of plant room planning

TYPICAL GAS 310 ECO PRO BOILER CONSTRUCTION

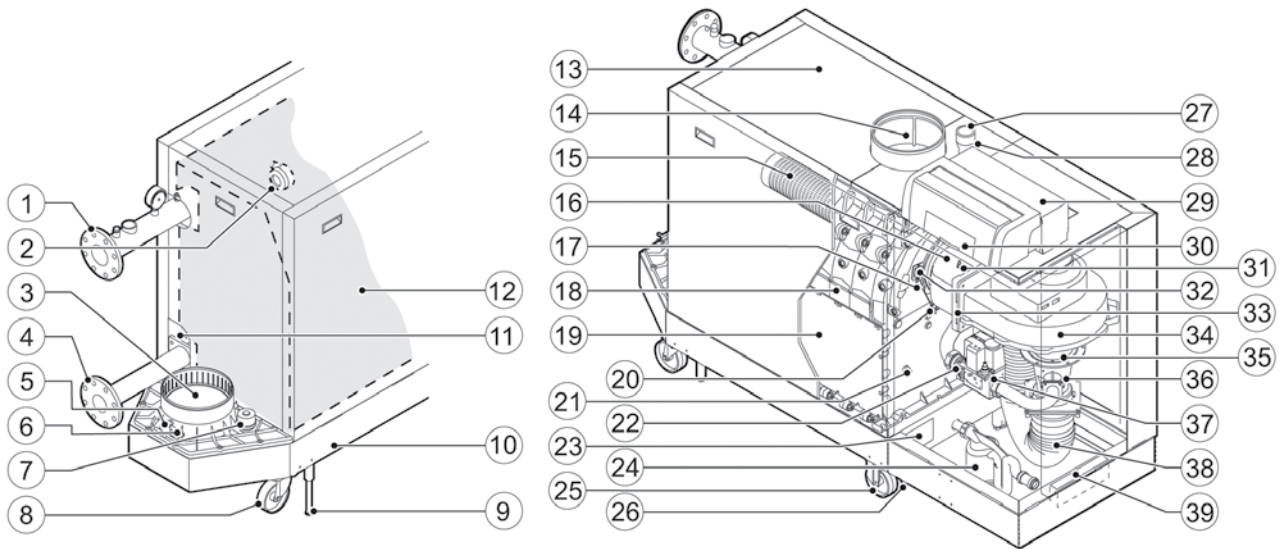

KEY

1	Flow connection	14	Air inlet	27	Gas connection
2	Air differential pressure switch	15	Burner	28	Gas pressure measurement point
3	Flue gas discharge pipe	16	Adapter	29	Control panel
4	Return connection	17	Ignition/ionisation electrode	30	Location for optional features or a control unit
5	Outlet for measuring combustion gases	18	Heat exchanger	31	Gas pressure measurement point
6	Flue gas thermostat (option)	19	Inspection hatch	32	Sight glass
7	Condensate collector sealant cap	20	Heat exchanger sensor	33	Flue gas non-return valve
8	Pivoting castor	21	Return sensor	34	Fan
9	Steadying jack	22	Gas filter	35	Extension piece
10	Base frame	23	Data plate	36	Venturi unit
11	Connection for second return (optional)	24	Siphon	37	Gas block
12	Heat exchanger insulation kit (option)	25	Fixed castor	38	Air inlet hose
13	Boiler casing	26	Jacking bolt	39	Document holder

TYPICAL GAS
610 ECO PRO
BOILER CONSTRUCTION

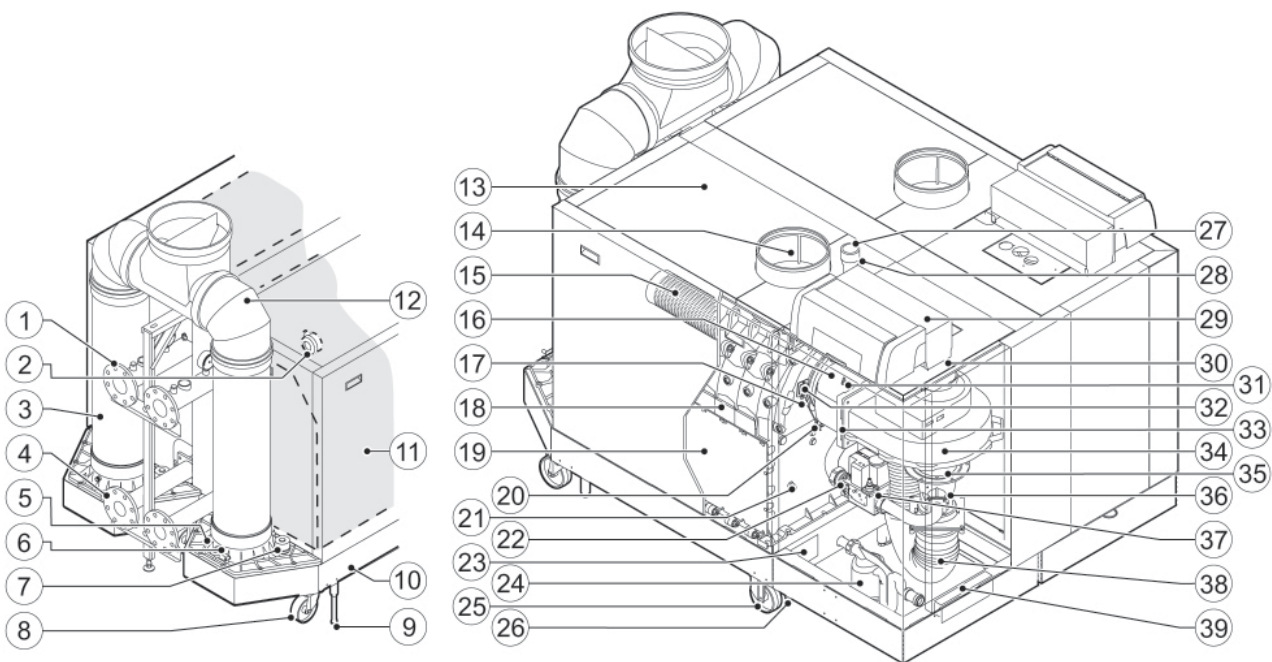

KEY

1	Flow connection	14	Air inlet	27	Gas connection
2	Air differential pressure switch	15	Burner	28	Gas pressure measurement point
3	Flue gas discharge pipe	16	Adapter	29	Control panel
4	Return connection	17	Ignition/ionisation electrode	30	Location for optional features or a control unit
5	Outlet for measuring combustion gases	18	Heat exchanger	31	Gas pressure measurement point
6	Flue gas thermostat (option)	19	Inspection hatch	32	Sight glass
7	Condensate collector sealant cap	20	Heat exchanger sensor	33	Flue gas non-return valve
8	Pivoting castor	21	Return sensor	34	Fan
9	Steadying jack	22	Gas filter	35	Extension piece
10	Base frame	23	Data plate	36	Venturi unit
11	Heat exchanger insulation kit (option)	24	Siphon	37	Gas block
12	Flue gas collector	25	Fixed castor	38	Air inlet hose
13	Boiler casing	26	Jacking bolt	39	Document holder



GAS 310/610 ECO PRO OPERATING PRINCIPLE

Combustion air is drawn into the inlet connection from the plant room (conventionally flued) or from outside via the concentric flue system (room-sealed) by an air supply fan. On the inlet side of the fan is a specially designed chamber (Venturi unit) which takes gas from the multiblock and mixes it in the correct ratio with the incoming air.



This mixing system ensures that the correct gas/air ratio is delivered to the pre-mix burner at all times. Depending on demand (under the dictates of flow/return sensor and other external/internal control inputs) the system determines the required boiler output. The control then varies the speed of the air supply fan which alters the volume of air being drawn into the Venturi. This change in volume is measured using air pressure differential which directly controls the volume of gas also being delivered to the Venturi. The resultant controlled mixture is delivered to the pre-mix burner.



This mixture is initially ignited by the combined ignition/ionisation probe, which monitors the state of the flame. If the flame is unstable or doesn't ignite within the pre-set safety time cycle, the controls will, after five attempts, shut the boiler down requiring manual intervention to reset the boiler. The digital display will indicate a flashing fault code confirming the reason for the failure. The products of combustion in the form of hot flue gases are forced through the heat exchanger transferring their heat to the system water (the flue gas temperature is reduced to approximately 5-8°C above the temperature of the system return water) then discharged via the condensate collector, to the flue gas outlet connection – and then into the atmosphere.

A vapour cloud will form at the flue gas terminal due to the low flue gas exit temperature. When the flue gas temperature falls below dew point (55°C), water vapour created during the combustion process will begin to condense out in the boiler, transferring its latent heat into the system water, increasing the output of the boiler without increasing the gas consumption. Condensation formed within the boiler and flue system is discharged from the boiler to an external drain via the drain pan and siphon supplied.

GAS 310 ECO PRO

TECHNICAL INFORMATION

	285/5	335/6	430/7	500/8	575/9	650/10
PERFORMANCE						
Nominal heat output central heating operation @ 80/60°C kW (min-max)	51-261	65-327	79-395	92-461	106-530	119-601
Nominal heat output central heating operation @ 50/30°C kW (max)	279	350	425	497	574	651
Nominal input (Hi) (min-max)	54-266	68-333	82-402	95-469	109-539	122-610
EFFICIENCY						
SBEM seasonal efficiency GCV	96.62%	96.64%	96.58%	96.09%	95.88%	95.75%
Efficiency – full load 100% NCV	98%	98.1%	98.2%	98.3%	98.4%	98.5%
Efficiency – part load 30% NCV	109.2%	109%	108.8%	108.6%	108.3%	108.1%
Seasonal space heating energy efficiency @ 80/60°C (100% full load) GCV	88.2%	88.3%	88.4%	N/a	N/a	N/a
Seasonal space heating energy efficiency @ 50/30°C (30% part load) GCV	98.6%	98.6%	98.5%	N/a	N/a	N/a
GAS						
Standard fuel	Natural gas	Natural gas	Natural gas	Natural gas	Natural gas	Natural gas
Max gas consumption m ³ /h	28.1	35.2	42.5	49.6	57	64.6
Min/max gas inlet pressure mbar	17-30	17-30	17-100	17-100	17-100	17-30
Gas connection size BSP inches	2" (F)	2" (F)	2" (F)	2" (F)	2" (F)	2" (F)
Flame protection	Ionisation	Ionisation	Ionisation	Ionisation	Ionisation	Ionisation
Ignition	Electronic	Electronic	Electronic	Electronic	Electronic	Electronic
FLUE (SUPPLIED AS STANDARD FOR CONVENTIONAL FLUE, OPTION FOR ROOM-SEALED AVAILABLE)						
Flue diameter mm I/D	250	250	250	250	250	250
Air inlet diameter mm I/D	250	250	250	250	250	250
Mass flue gas flow rate kg/h	91-448	114-560	138-676	160-789	183-907	205-1026
Flue gas temperature (80/60°C) °C	30-80	30-80	30-80	30-80	30-80	30-80
Residual fan duty Pa	130	120	130	150	150	150
HYDRAULICS						
Water content litres	49	60	71	82	93	104
Hydraulic resistance @ 20°C ΔT mbar	113	110	120	110	125	130
Resistance @ 11°C ΔT mbar	374	364	397	364	413	435

GAS 310 ECO PRO TECHNICAL INFORMATION

	285/5	335/6	430/7	500/8	575/9	650/10
HYDRAULICS						
Nominal flow rate @ 20°C ΔT l/s	3.12	3.91	4.72	5.51	6.34	7.19
Nominal flow rate @11°C ΔT l/s	5.68	7.11	8.59	10.03	11.53	13.07
Minimum flow rate m ³ /hr	3.4	4.2	5.1	5.9	6.8	7.8
Condensate outlet	32mm I/D	32mm I/D	32mm I/D	32mm I/D	32mm I/D	32mm I/D
Connection size flow and return flange PN16	NW 80	NW 80	NW 80	NW 80	NW 80	NW 80
Connection size secondary return flange PN16	NW 65	NW 65	NW 65	NW 65	NW 65	NW 65
Standard operating temperature °C	20-90	20-90	20-90	20-90	20-90	20-90
Max operating temperature °C	90	90	90	90	90	90
High limit temperature °C	110	110	110	110	110	110
Max water operating pressure bar	7	7	7	7	7	7
Min water operating pressure bar	0.8	0.8	0.8	0.8	0.8	0.8
GENERAL						
Dry weight kg	364	398	433	495	531	568
Dimensions (WxHxD)	1862 x 1500 x 716	1862 x 1500 x 716	1862 x 1500 x 716	2172 x 1500 x 716	2172 x 1500 x 716	2172 x 1500 x 716
NO _x (Dry, 0% O) mg/kWh	33	35	32	29	36	26
Noise levels dB(A) at 1 metre	61	61	65	65	65	65
ECO Design Sound Power Levels LWA indoors dB	69	69	69	N/a	N/a	N/a
Standby heat loss %	0.21	0.18	0.15	0.13	0.12	0.11
ELECTRICAL						
Nominal power supply	230v-1ph-50hz	230v-1ph-50hz	230v-1ph-50hz	230v-1ph-50hz	230v-1ph-50hz	230v-1ph-50hz
Power consumption w	6-279	6-334	6-426	6-543	6-763	7-723
Modulating input v dc	0-10	0-10	0-10	0-10	0-10	0-10
Start current amps	4	4	4	4	4	4
Fuse rating amps	10	10	10	10	10	10
Controls voltage	24 (max 4va)	24 (max 4va)	24 (max 4va)	24 (max 4va)	24 (max 4va)	24 (max 4va)
Insulation class IP	X1B	X1B	X1B	X1B	X1B	X1B
Run current amps	1.4	1.4	1.4	1.4	1.4	1.4

GAS 610 ECO PRO

TECHNICAL INFORMATION

	570 (2 x 310/5)	710 (2 x 310/6)	860 (2 x 310/7)	1000 (2 x 310/8)	1150 (2 x 310/9)	1500 (2 x 310/10)
PERFORMANCE						
Nominal heat output central heating operation @ 80/60°C kW (min-max)	69-522	87-654	123-790	122-922	148-1060	158-1202
Nominal heat output central heating operation @ 50/30°C kW (max)	558	700	850	994	1148	1303
Nominal input (Hi) (min-max)	72-532	91-666	128-804	127-938	170-1078	162-1220
EFFICIENCY						
SBEM seasonal efficiency GCV	96.62%	96.64%	96.58%	96.09%	95.88%	95.75%
Efficiency – full load 100% NCV	98%	98.1%	98.2%	98.3%	98.4%	98.5%
Efficiency – part load 30% NCV	109.2%	109%	108.8%	108.6%	108.3%	108.1%
ECO Design useful efficiency @ 80/60°C (100% full load) GCV	N/a	N/a	N/a	N/a	N/a	N/a
ECO Design useful efficiency @ 50/30°C (30% part load) GCV	N/a	N/a	N/a	N/a	N/a	N/a
GAS						
Standard fuel	Natural gas	Natural gas	Natural gas	Natural gas	Natural gas	Natural gas
Max gas consumption m ³ /h	56.2	70.4	85	99.2	114	129.2
Min/max gas inlet pressure mbar	17-30	17-30	17-100	17-100	17-100	17-30
Gas connection size BSP inches	2 x 2" (F)	2 x 2" (F)	2 x 2" (F)	2 x 2" (F)	2 x 2" (F)	2 x 2" (F)
Flame protection	Ionisation	Ionisation	Ionisation	Ionisation	Ionisation	Ionisation
Ignition	Electronic	Electronic	Electronic	Electronic	Electronic	Electronic
FLUE (SUPPLIED AS STANDARD FOR CONVENTIONAL FLUE, OPTION FOR ROOM-SEALED AVAILABLE)						
Flue diameter mm I/D	350	350	350	350	350	350
Air inlet diameter mm I/D	250 x 2	250 x 2	250 x 2	250 x 2	250 x 2	250 x 2
Mass flue gas flow rate kg/h	182-896	228-1120	276-1352	320-1578	366-1814	410-2052
Flue gas temperature (80/60°C) °C	30-80	30-80	30-80	30-80	30-80	30-80
Residual fan duty Pa	130	120	130	130	130	150
HYDRAULICS						
Water content litres	49 (per module)	60 (per module)	71 (per module)	82 (per module)	93 (per module)	104 (per module)
Hydraulic resistance @ 20°C ΔT mbar	113 (per module)	110 (per module)	120 (per module)	110 (per module)	125 (per module)	130 (per module)
Resistance @ 11°C ΔT mbar	374 (per module)	364 (per module)	397 (per module)	364 (per module)	413 (per module)	435 (per module)

GAS 610 ECO PRO
TECHNICAL INFORMATION

	570 (2 x 310/5)	710 (2 x 310/6)	860 (2 x 310/7)	1000 (2 x 310/8)	1150 (2 x 310/9)	1500 (2 x 310/10)
HYDRAULICS						
Nominal flow rate @ 20°C ΔT l/s	3.12 (per module)	3.91 (per module)	4.72 (per module)	5.51 (per module)	6.34 (per module)	7.19 (per module)
Nominal flow rate @11°C ΔT l/s	5.68 (per module)	7.11 (per module)	8.59 (per module)	10.03 (per module)	11.53 (per module)	13.07 (per module)
Minimum flow rate m ³ /hr	3.4 (per module)	4.2 (per module)	5.1 (per module)	5.9 (per module)	6.8 (per module)	7.8 (per module)
Condensate outlet	2 x 32mm I/D	2 x 32mm I/D	2 x 32mm I/D	2 x 32mm I/D	2 x 32mm I/D	2 x 32mm I/D
Connection size flow and return flange PN16	2 x NW 80	2 x NW 80	2 x NW 80	2 x NW 80	2 x NW 80	2 x NW 80
Connection size secondary return flange PN16	2 x NW 65	2 x NW 65	2 x NW 65	2 x NW 65	2 x NW 65	2 x NW 65
Standard operating temperature °C	20-90	20-90	20-90	20-90	20-90	20-90
Max operating temperature °C	90	90	90	90	90	90
High limit temperature °C	110	110	110	110	110	110
Max water operating pressure bar	7	7	7	7	7	7
Min water operating pressure bar	0.8	0.8	0.8	0.8	0.8	0.8
GENERAL						
Dry weight kg	707	771	837	957	1025	1095
Dimensions (WxHxD)	1460 x 1726 x 1862	1460 x 1726 x 1862	1460 x 1726 x 1862	1460 x 1726 x 2172	1460 x 1726 x 2172	1460 x 1726 x 2172
NOx (Dry, 0% O) mg/kWh	33	35	32	29	36	26
Noise levels dB(A) at 1 metre	64	64	68	68	68	68
ECO Design Sound Power Levels LWA indoors dB	N/a	N/a	N/a	N/a	N/a	N/a
Standby heat loss %	0.21	0.18	0.15	0.13	0.12	0.11
ELECTRICAL						
Nominal power supply	2 x 230v-1ph-50hz	2 x 230v-1ph-50hz	2 x 230v-1ph-50hz	2 x 230v-1ph-50hz	2 x 230v-1ph-50hz	230v-1ph-50hz
Power consumption w	12-558	12-668	12-852	12-1086	12-1526	14-1446
Modulating input v dc	0-10	0-10	0-10	0-10	0-10	0-10
Start current amps	2 x 4	2 x 4	2 x 4	2 x 4	2 x 4	2 x 4
Fuse rating amps	2 x 10	2 x 10	2 x 10	2 x 10	2 x 10	2 x 10
Controls voltage	2 x 24 (max 4va)	2 x 24 (max 4va)	2 x 24 (max 4va)	2 x 24 (max 4va)	2 x 24 (max 4va)	2 x 24 (max 4va)
Insulation class IP	X1B	X1B	X1B	X1B	X1B	X1B
Run current amps	2 x 1.4	2 x 1.4	2 x 3.8	2 x 3.8	2 x 3.8	2 x 3.8

SUGGESTED ENGINEERING SPECIFICATION

GAS 310 ECO PRO

□ CONSTRUCTION

The boiler will consist of a sectional cast aluminium heat exchanger with other major components contained within a rigid steel frame with removable casing parts for maintenance purposes. The boiler will come complete with wheels to enable the assembled unit to be easily manoeuvred into position within the plant room on site with the minimum of effort. All major electrical and electronic controls shall be contained within the instrument panel mounted on top of the boiler at the opposite end to the connections facing to the front (long side) but can be rotated 90° towards the short side to suit site location. The boiler shall be able to pass through 720mm standard door and shall be delivered fully assembled.

□ HYDRAULIC, GAS AND FLUE CONNECTIONS

The boiler will be available with flow and return connections on the left or right hand end of the boiler (this must be decided during coordination), with the gas connection on the top of the boiler. The flue gas outlet, complete with a condensate connection shall be at a low level on the same end as the F/R connections. The combustion air inlet is located at the top of the boiler. The boiler will be suitable for room-sealed or conventional flue applications and designed to operate at working pressures not exceeding seven bar.

□ OPERATION

The boiler shall come complete with a modulating control system that limits the maximum difference in temperature between the heating flow and return and the maximum speed at which the flow temperature increases. The boiler shall come complete with a pre-mix burner (NG) with the gas/air ratio control system controlled internally. An intelligent, advanced boiler control shall continuously monitor the boiler conditions, varying the heat output to suit the system load. The controls shall be able to react to external negative influences in the rest of the system (flow rates and air/gas supply problems) maintaining boiler output for as long as possible without resorting to a lock out condition. Should a negative effect happen in the system the boiler shall reduce its output and/or shut down (shut-off mode), awaiting the negative conditions to return to normal before re-starting. The control cannot override the standard flame safety controls. Standard frost protection shall activate below 7°C with stage one activating the system/shunt pump. Stage two shall activate below 3°C with boiler switching on to 10°C flow.

□ CONTROLS

The boiler will include a controls package that allows the actual and set values to be read and adjusted on the built-in digital display, which also provides normal operating and fault code indication. The controls shall come as standard with the following inputs/outputs:

- 0-10V input (flow or load control)
- Common alarm
- High limit lock out
- External gas valve control (optional)
- Low water protection (optional)
- Frost protection
- External pump control
- Hydraulic pressure sensor (optional)
- Shutdown interlock
- Min gas pressure switch (optional)
- Release input
- Volt free (enable signal)
- Open therm control.

□ FEATURES

- Ultra-low NO_x <36mg/kWh
- Fully modulating
- Quiet operation <52dB(A)
- Supplied on fully built-in wheels
- Air pressure differential sensor (LDS)
- ErP compliant
- Digital diagnostic display
- Pre-mix burner
- Left or right hand versions available
- In-built passive flue gas non-return valve.

□ DIMENSIONS AND CONNECTIONS

The small footprint of this range alongside its easy disassembly and its space saving configurations, makes it ideal for modular arrangement and particularly suitable for retrofit applications.

GAS 610 ECO PRO

□ CONSTRUCTION

The boiler will consist of a sectional cast aluminium heat exchanger with other major components contained within a rigid steel frame with removable casing parts for maintenance purposes. The boiler will consist of two modules connected together to share the same air-box. Each section is able to perform independently to each other and should one module go to fault the other will remain operational. The boiler will be complete with wheels to enable the assembled unit to be easily manoeuvred into position within the plant room on site with the minimum effort. All major electrical and electronic controls shall be contained in the instrument panel mounted on top of the boiler at the opposite end to the connections facing to the front (long side) but can be rotated 90° towards the short side to suit site location. The boiler will be able to pass through 720mm wide standard door fully assembled in two sections to allow ease of positioning.

□ HYDRAULIC, GAS AND FLUE CONNECTIONS

The boiler will be available with flow and return connections on the left or right hand end of the boiler (this must be decided during coordination), with the gas connection on the top of the boiler. The flue gas outlet, complete with a condensate connection shall be at low level on the same end as the F/R connections. The combustion air inlet is located at the top of the boiler. The boiler will be suitable for room-sealed or conventional flue applications and designed to operate at working pressures not exceeding seven bar. The boiler will have two flows and returns at one end with a combined flue gas outlet. The control panel will be rotated to enable the boiler connections to be on the left or right hand side.

□ OPERATION

The boiler will come complete with a modulating control system that limits the maximum difference in temperature between the heating flow and return and the maximum speed at which the flow temperature increases. The boiler will come complete with a pre-mix burner (NG) with the gas/air ratio control system controlled internally. An intelligent, advanced boiler control shall continuously monitor the boiler conditions, varying the heat output to suit the system load. The control will be able to react to external negative influences in the rest of the system (flow rates and air/gas supply problems) maintaining boiler output for as long as possible without resorting to a lock out condition. Should a negative effect happen in the system the boiler shall reduce its output and/or shut down (shut-off mode), awaiting the negative conditions to return to normal

before re-starting. The control cannot override the standard flame safety controls. Standard frost protection shall activate below 7°C with stage one activating the system/shunt pump. Stage two shall activate below 3°C with the boiler switching on to 10°C flow.

□ CONTROLS

The boiler will include a controls package that allows the actual and set values to be read and adjusted on the built-in digital display, which also provides normal operating and fault code indication. The controls shall come as standard with the following inputs/outputs:

- 0-10V input (flow or load control)
- Common alarm
- High limit lock out
- External gas valve control (optional)
- Low water protection (optional)
- Frost protection
- External pump control
- Hydraulic pressure sensor (optional)
- Shutdown interlock
- Min gas pressure switch (optional)
- Release input
- Volt free (enable signal)
- Open therm control.

□ FEATURES

- Ultra-low NO_x <36mg/kWh
- Fully modulating
- Quiet operation <52dB(A)
- Supplied on fully built-in wheels
- Air pressure differential sensor (LDS)
- ErP compliant
- Digital diagnostic display
- Premix burner
- In-built passive flue gas non-return valve.

□ DIMENSIONS AND CONNECTIONS

The small footprint of this range alongside its easy disassembly and its space saving configurations, makes it ideal for modular arrangement and particularly suitable for retrofit applications.



GAS 310 ECO PRO DIMENSIONS

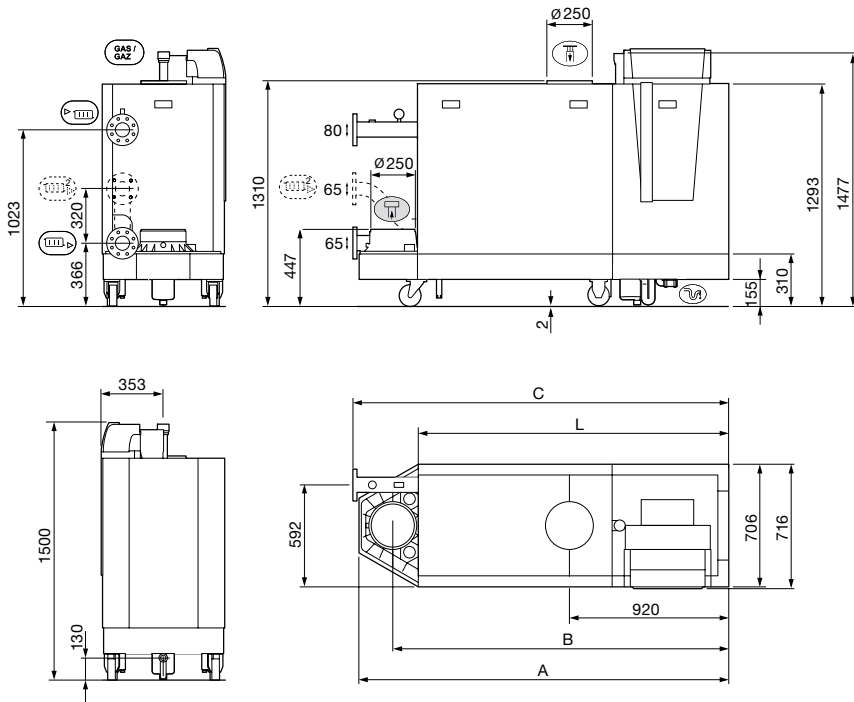

BOILER TYPE	A (MM)	B (MM)	C (MM)	L (MM)
310-285 (5)	1833	1635	1862	1490
310-355 (6)	1833	1635	1862	1490
310-430 (7)	1833	1635	1862	1490
310-500 (8)	2142	1944	2172	1800
310-575 (9)	2142	1944	2172	1800
310-650 (10)	2142	1944	2172	1800

KEY

	Heating circuit flow (80mm); Flange NW 80 (Standard DIN 2576)
	Heating circuit return (65mm); Flange NW 80 (Standard DIN 2576)
	Gas connection; G2" (Female thread)
	Condensates discharge; 32mm (Internal)
	Flue gas outlet; Ø 250mm
	Air intake; Ø 250mm
	Second return (optional); Flange NW 80 (Standard DIN 2576)

Note: Heating flow pipe 80mm with a mating flange NW 80 (PN16). Return flow pipe 65mm with a mating flange NW 80 (PN16). The optional return pipe is also 65mm, and fitted with a NW80 (PN16) mating flange. The service areas are shown on page 20.

GAS 310
ECO PRO
CONFIGURATION

The service side with the inspection hatch on the heat exchanger is considered to be the front of the boiler. This boiler is available in both a left-hand and right-hand version. This means that the hydraulic connections and the flue gas discharge are situated on either the left or the right-hand side of the boiler. The control panel is on the front as standard, but can easily be rotated so that it is on the short side. To make the boiler level and to raise the wheels off the floor, the adjustment jacks must be used. Turn the adjustment bolts out as soon as the boiler is placed in the correct position. The picture shows the support surface of the boiler. This is the position of the adjustment bolts.

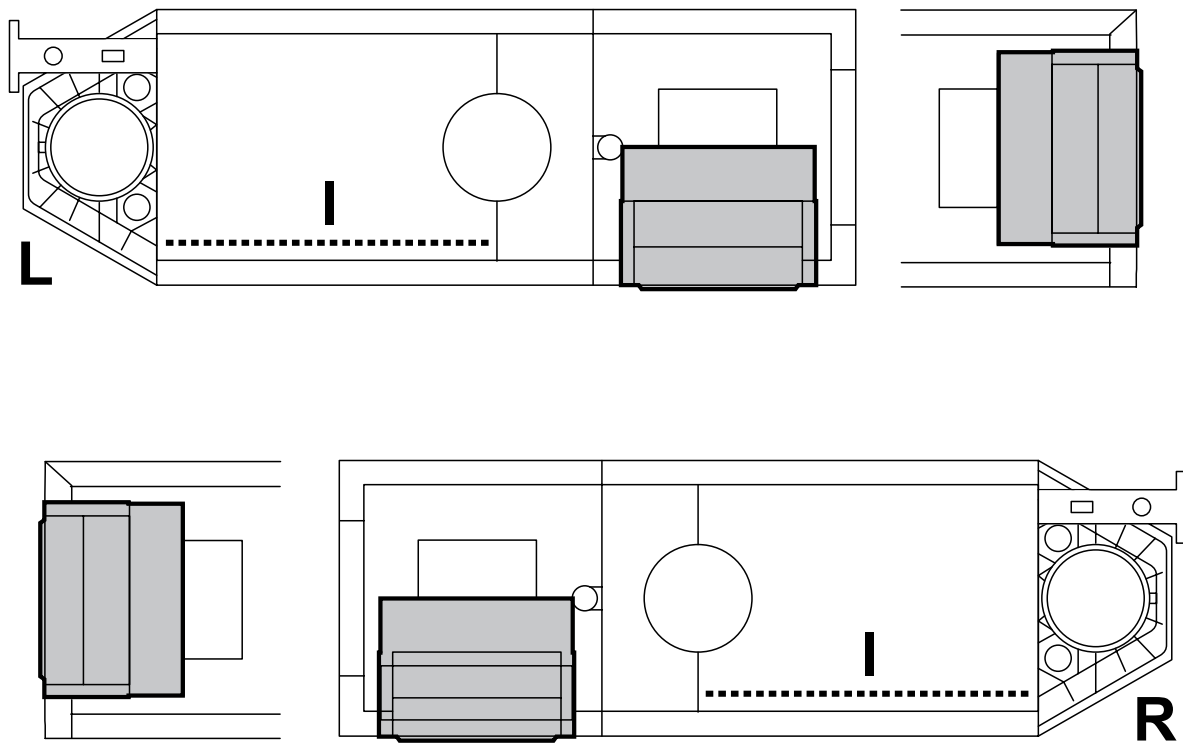

T003785-C

KEY

L Left version

R Right version

I Inspection hatch



GAS 610 ECO PRO DIMENSIONS

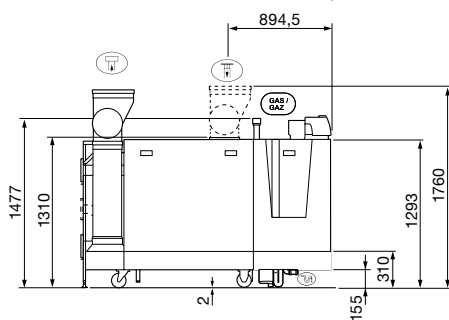
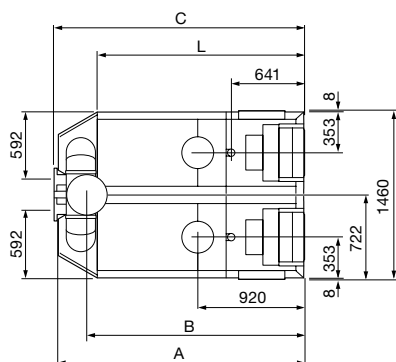
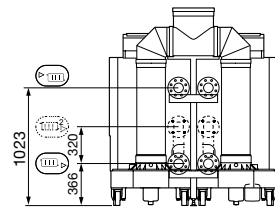
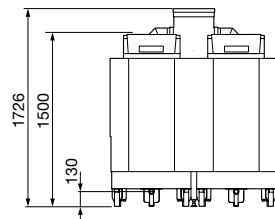

T003766-F

BOILER TYPE	A (MM)	B (MM)	C (MM)	L (MM)
610-570 (5)	1833	1582	1862	1490
610-710 (6)	1833	1582	1862	1490
610-860 (7)	1833	1582	1862	1490
610-1000 (8)	2142	1892	2172	1800
610-1150 (9)	2142	1892	2172	1800
610-1300 (10)	2142	1982	2172	1800

KEY

	Heating circuit flow (80mm); Flange NW 80 (Standard DIN 2576)
	Heating circuit return (65mm); Flange NW 80 (Standard DIN 2576)
	Gas connection; G2" (Female thread)
	Condensates discharge; 32mm (Internal)
	Flue gas outlet; Ø 350mm
	Air intake; Ø 250mm Air supply collector (Optional); Ø 350mm
	Second return (optional); Flange NW 80 (Standard DIN 2576)

Note: Heating flow pipe 80mm with a mating flange NW 80 (PN16). Return flow pipe 65mm with a mating flange NW 80 (PN16). The optional return pipe is also 65mm and fitted with a NW80 (PN16) mating flange.

GAS 610 ECO PRO CONFIGURATION

The Gas 610 Eco Pro boiler is not available with a choice between left or right hand versions, but the control panel can easily be rotated to enable the boiler connections to be on the left or right hand side. To make the boiler level and to raise the wheels off the floor, the adjustment bolts must be used. Turn the adjustment bolts out as soon as the boiler is placed in the correct position. The picture shows the support surface of the boiler. This is the position of the adjustment bolts.

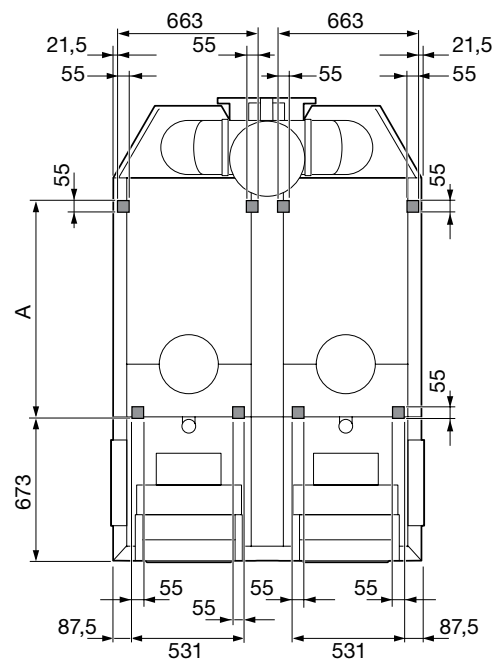
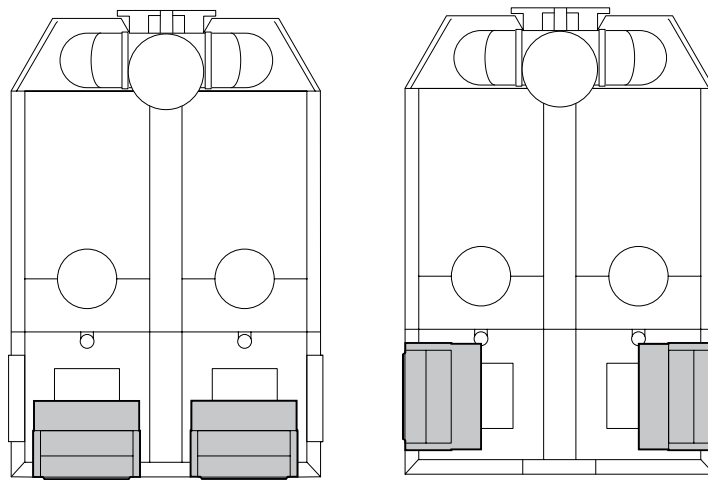

GAS 310/610 ECO PRO DIMENSIONS

The wheels are designed for transport purposes only and not for use when the boiler is in its final position. If required for internal transport, the boiler can be dismantled into smaller parts for transport. The boiler can be stripped of:

- casing components
- gas/air components
- the frame section on the instrument panel side.

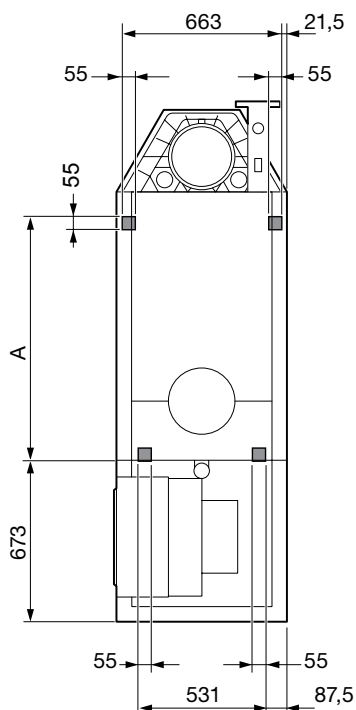

T003474-B

Diagram shows position of support feet.

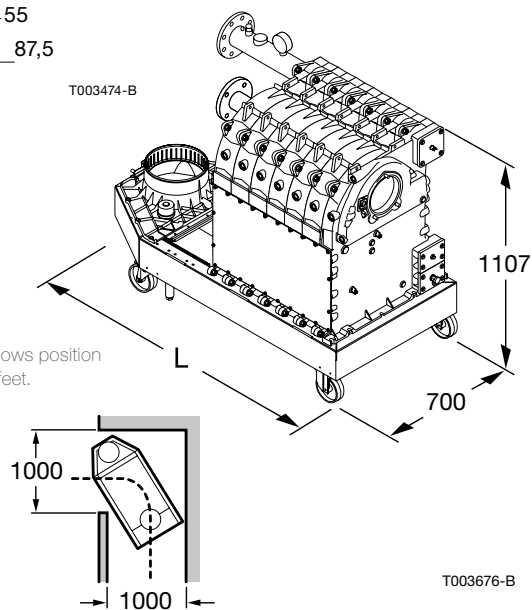

T003676-B

GAS 310/610 ECO PRO

BOILER TYPE	A (MM)
310-285/610-570	723
310-355/610-710	723
310-430/610-860	723
310-500/610-1000	1032
310-575/610-1150	1032
310-650/610-1300	1032

GAS 310/610 ECO PRO

BOILER TYPE	L (MM)
310-285/610-570	1160
310-430/610-710	1160
310-430/610-860	1160
310-500/610-1000	1469
310-575/610-1150	1469
310-650/610-1300	1469

See the diagram and table for the dimensions of the largest remaining transport part, the frame section with heat exchanger and water connections. For information on fitting the parts, refer to the assembly instructions delivered with the boiler.

SPACE SAVING CONFIGURATIONS

The Gas 310/610 can be configured in a multitude of ways.
Examples below:

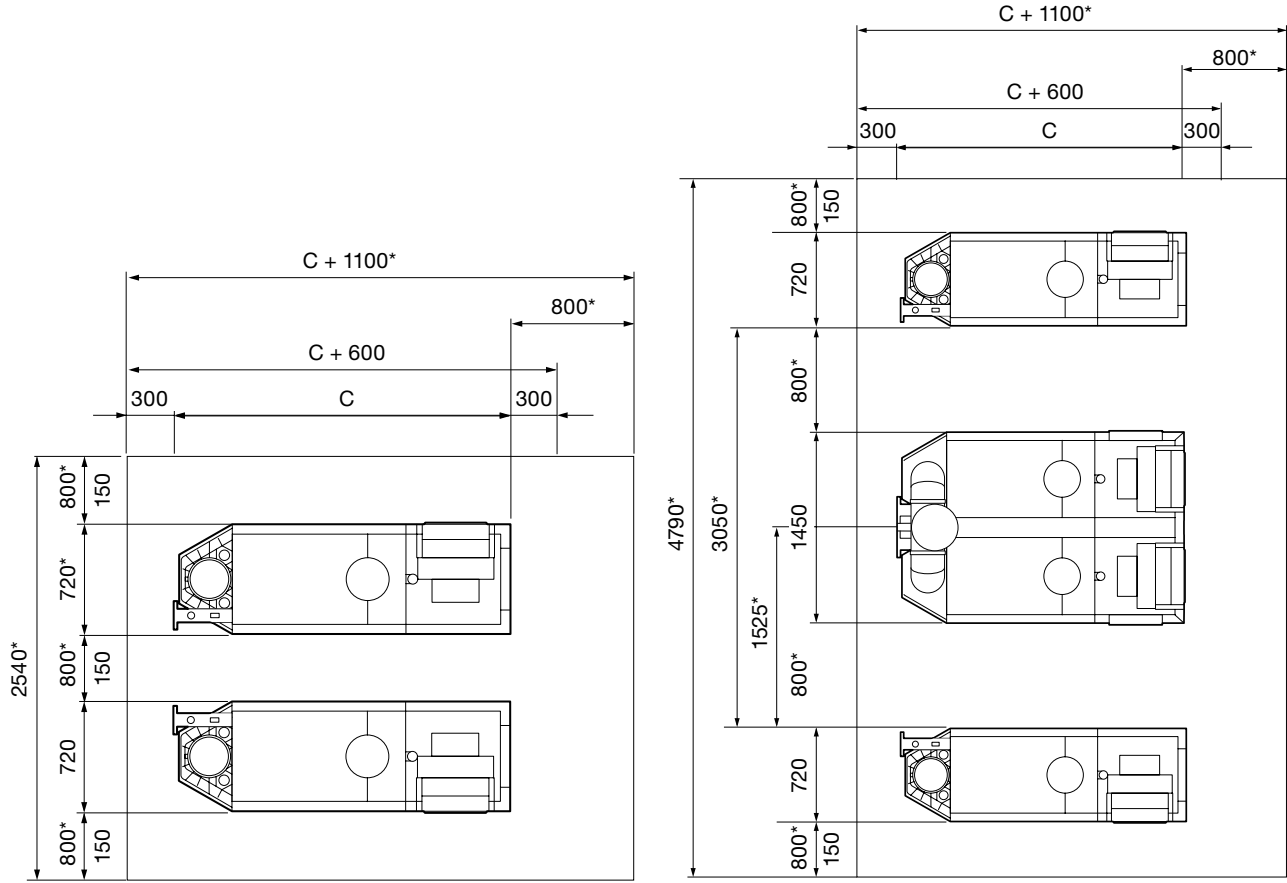

*Indicates spacing required if this is the operating side.

GAS 310 ECO PRO MAINTENANCE AREAS

For the dimensions of C/C1, see page 14.

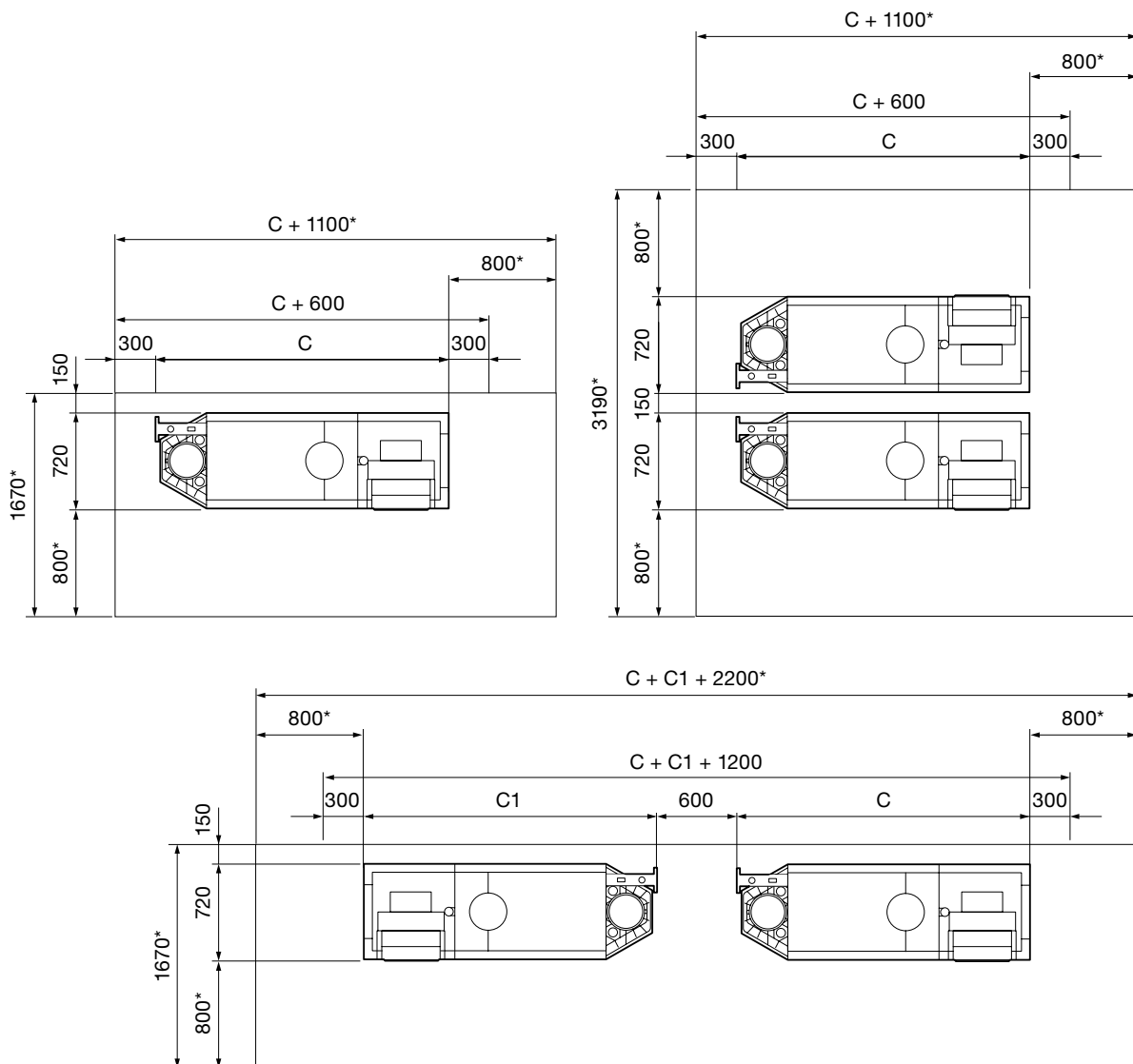

T003499-B

*Spacing required if this is operating side.

GAS 610
ECO PRO
MAINTENANCE
AREAS

For the dimensions of C/C1, see page 18.

A technical clearance of at least 80cm is required at the front (service side) of the boiler. However, we recommend that the clearance is at least 100cm. We recommend a clearance of at least 40cm above the boiler. If the air supply filter is used, there must be a clearance of at least 65cm. A minimum of 30cm is required on the side of the flue gas discharge, and a minimum of 30cm is also required on the other side, or 80cm, if this is the operating side.

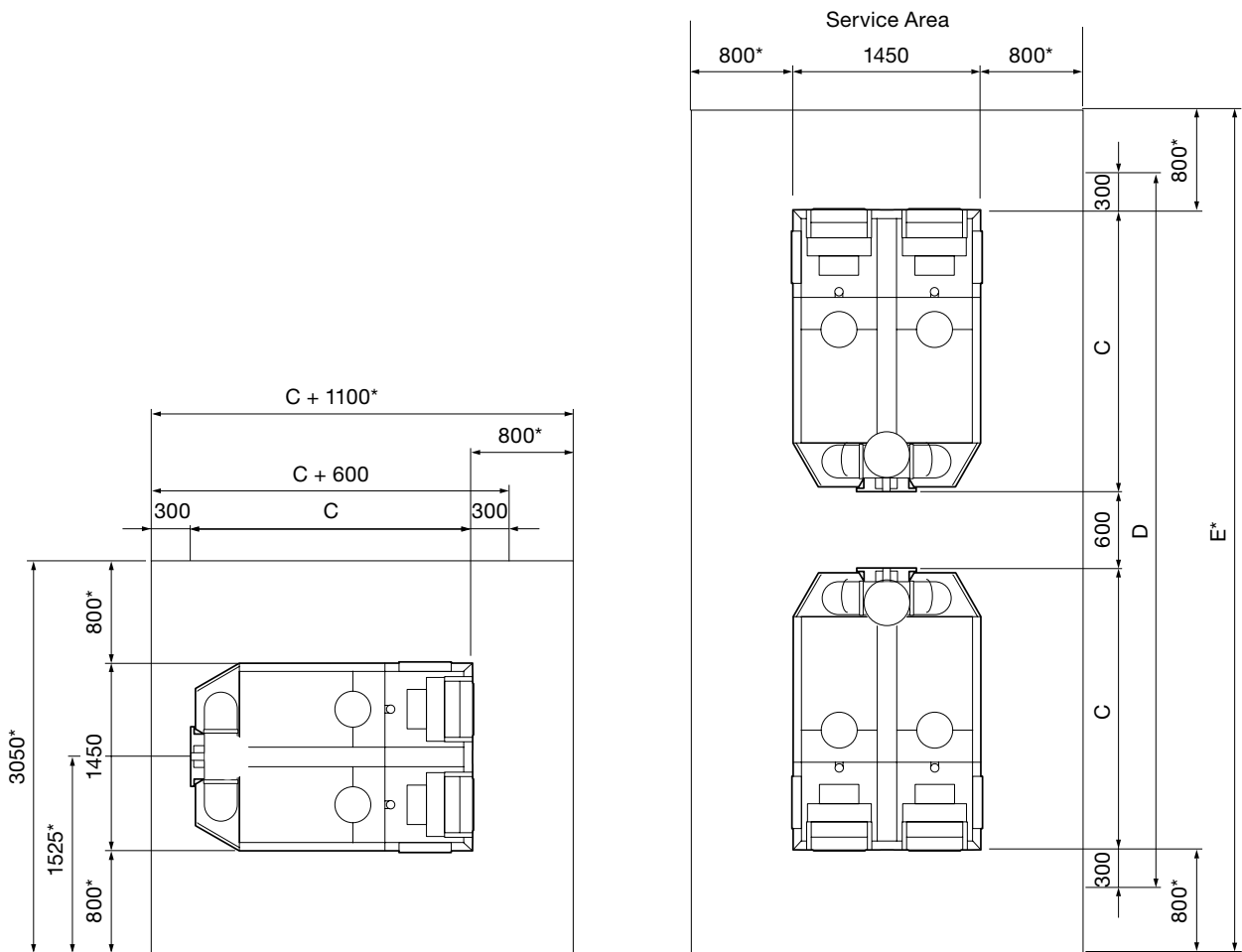

T003768-E

*Spacing required if this is operating side.

SINGLE GAS 310 ECO PRO TYPICAL INSTALLATION

Using the optional secondary return

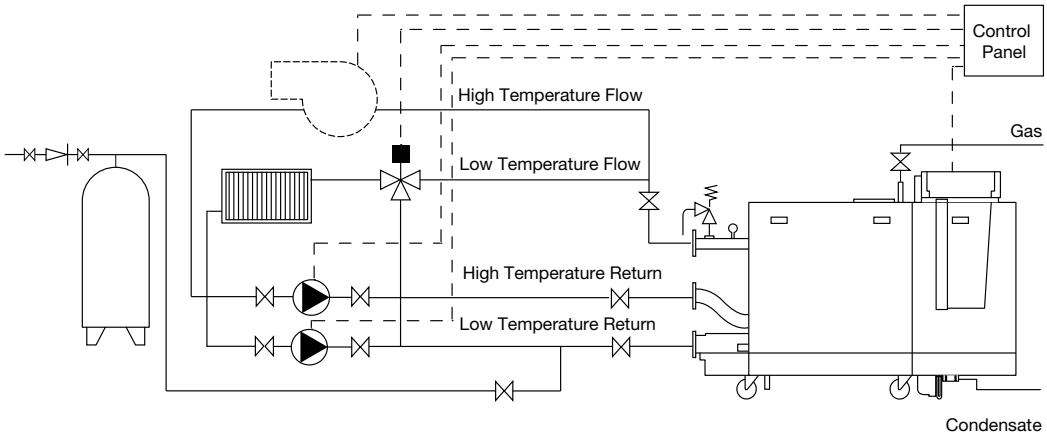

MULTIPLE BOILER GAS 310 ECO PRO TYPICAL INSTALLATION

Using the optional secondary return

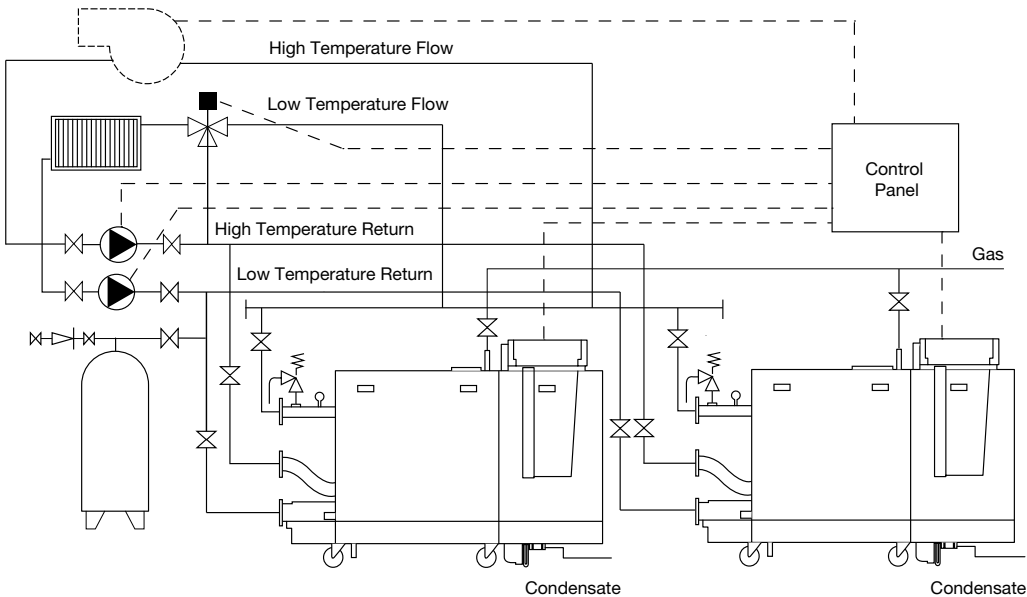

Typical diagrams shown do not constitute a full system design and should be used for general concept information only. All equipment should be installed to manufacturer's instructions and must comply with current regulations in force.

ELECTRICAL CONNECTIONS AND CONTROLS

□ GENERAL

General specifications apply to the Gas 310 Eco Pro and to the Gas 610 Eco Pro. These boilers are supplied as standard with electronic operating and flame ionisation safety controls with a specially designed microprocessor at the heart of the system. The boilers are pre-wired. All external connections can be made on the terminal strips.

□ POWER SUPPLY

The boilers are suitable for a 230V-50Hz supply with phase/neutral/earth. Other connection values are only acceptable if an isolating transformer is installed. The boilers are sensitive to phase/neutral and therefore have a facility to ensure that phase and neutral are correctly connected.

□ AUTOMATIC CONTROLS

The Gas 310/610 Eco Pro has a unique boiler code. This together with other data (including boiler type, counter readings, etc.) is stored in a code-key that belongs to the boiler. If the control unit is replaced, the counter readings remain stored in the code-key.

□ TEMPERATURE CONTROL

The boiler is equipped with electronic temperature control based on flow, return, and boiler block temperature sensors. The flow temperature can be set between 20 and 90°C. The boiler reduces its power when the set outlet-temperature is attained. The cut out temperature is the set heating outlet-temperature + 5°C.

□ LOW WATER LEVEL PROTECTION (FLOW AND CONTENT)

The boiler is fitted with a safety device to prevent the shortage of water based on temperature measurements (temperature difference between flow and return).

If $\Delta t = 25K$ is reached (factory setting), the boiler reduces its output by modulating to remain in operation as long as possible.

If $\Delta t \geq 25K$ the boiler goes into part load.

If $\Delta t > 25 + 5K$ the boiler goes into a normal control stop (temporary shutdown).

□ HIGH LIMIT PROTECTION

The maximum temperature protection switches the boiler off if the water temperature is too high (110°C) and locks it on the control box. The minimum off time is preset to a fixed value (*1 seconds). Once the fault has been rectified, the boiler can be reset by pressing the reset button for two seconds.

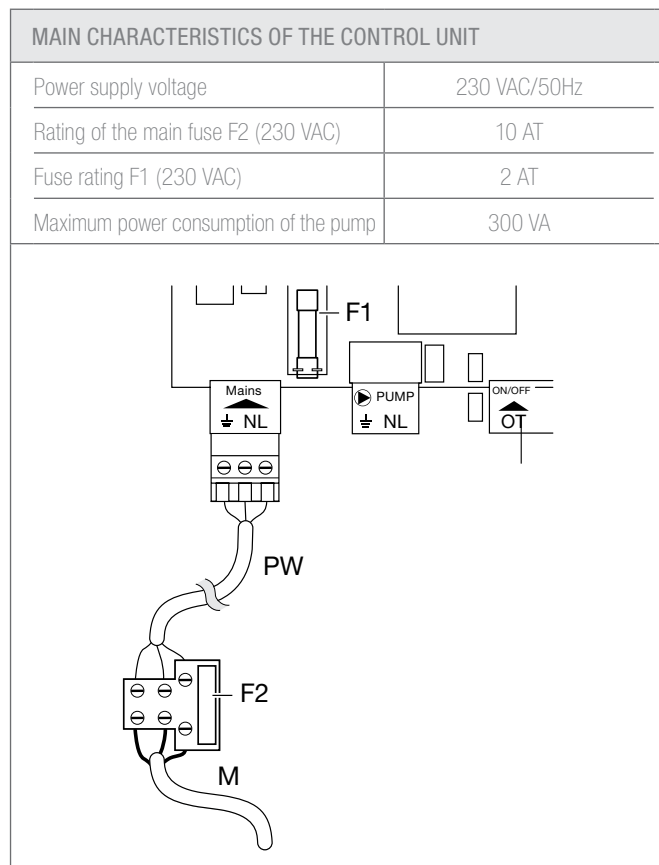

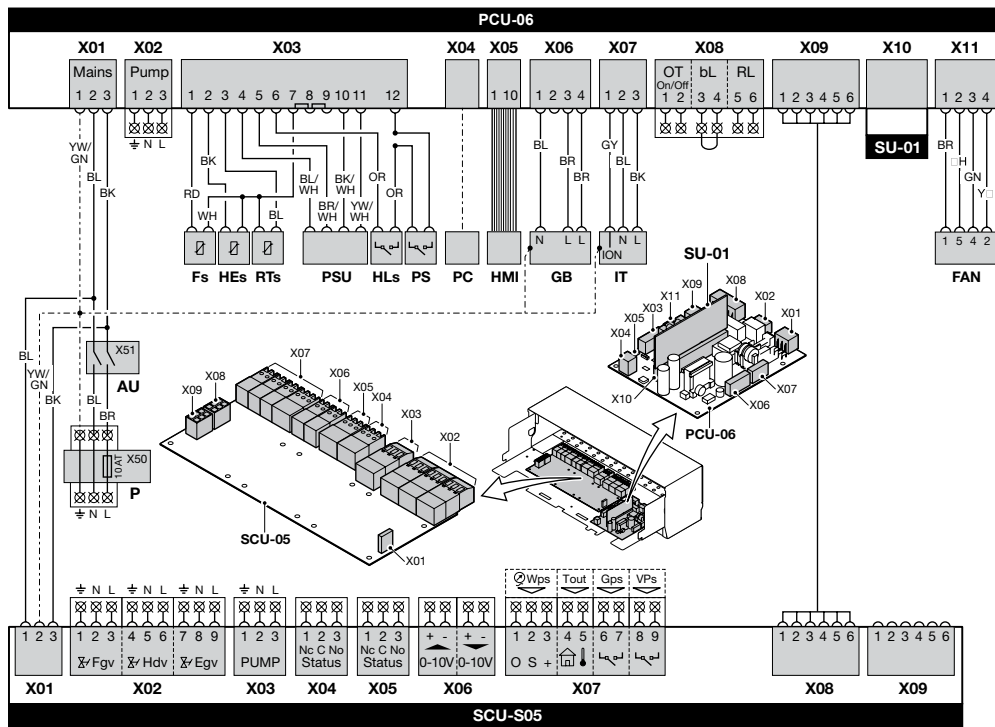

R000236-B

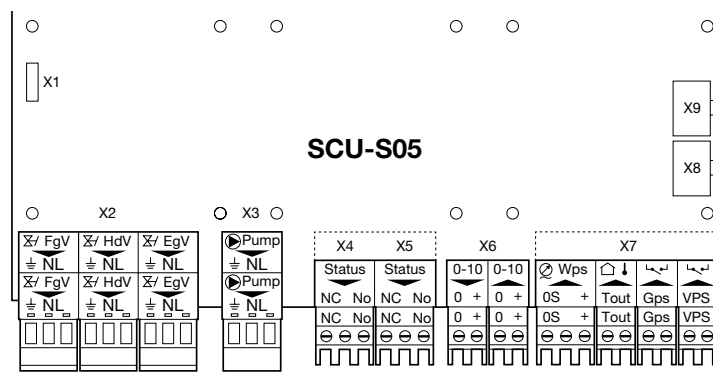

T003684-B

KEY

CU-S05	Extended control PCB	L	Phase GB gas block	PS	Air differential pressure switch
PCU-06	Standard control PCB	FS	Flow switch	PC	Connecting a computer
SU-01	Safety PCB	HEs	Heat exchanger sensor	HMI	Control panel
AU	On/off switch	RTs	Return sensor	GB	Gas block
P	Power supply	PSU	Storage parameter	IT	Ignition transformer
N	Neutral	HLs	Safety thermostat	FAN	Fan

SAFETY INTERLOCKS

This applies to the Gas 310 Eco Pro and to each module on the Gas 610 Eco Pro. The boilers are supplied with two interlocks as standard.

□ SHUTDOWN INTERLOCK

A shutdown interlock carrying a 24 Volt AC boiler control circuit. This input does not require manual reset. Any external devices required to stop the boiler (e.g. limit switches of throttling valves, minimum gas pressure switches) should be wired in series and connected to terminals BL. Breaking the circuit will activate the safety interlock and put the boiler into a shut off condition.

□ RELEASE INPUT

A lockout interlock carrying a 24 Volt AC boiler control circuit. This input requires manual reset if activated. Any external devices required to stop the boiler (e.g. maximum gas pressure switch) must be volt free and should be wired in series and connected to terminals RL. Closing the circuit will activate the safety interlock.

□ HYDRAULIC PRESSURE SENSOR (WPS)

The hydraulic pressure sensor registers the water pressure and can shut the boiler down when the minimum water pressure is reached. To activate this blocking option, a minimum pressure must be set with parameter P 2 8 (Factory setting 0 = off). Connect the hydraulic pressure sensor to the WPS terminals of the terminal strip.

0 = Earth or neutral of the power supply
S = Signal or output from the sensor
+ = Supply voltage

□ OPERATION SIGNAL

As standard the boilers are supplied with internal relays to indicate boiler run. Contact load:

- Maximum voltage: 230 Volts
- Maximum current: 1 Amp.

□ COMMON ALARM (LOCKOUT)

As standard, the boilers are supplied with an internal change over relay to indicate common alarm. The relay contacts are volt free and can be connected to confirm operation with closed or open contacts. Contact load:

- Maximum voltage: 230 Volts
- Maximum current: 1 Amp.

□ EXTERNAL GAS VALVE CONTROL

If there is a heat demand, an alternating voltage of 230 VAC, 1 Amp (maximum) becomes available on the EgV terminals of the connector to control an external gas valve. Additional external interlocks (by others) may be required in a multi boiler installation.

IMPORTANT! This supply cannot be used to control an external gas valve if it supplies other appliances. Contact load:

- External gas valve voltage: 230 Volts
- Maximum current: 1 Amp.

□ OPTIONAL ACCESSORIES

- Hydraulic pressure sensor
- Minimum gas pressure switch
- Second return
- Cleaning tool
- Water pressure sensor adaptor
- Gas leak switch (VPS)
- Air filter
- Recom kit
- Combined roof flue kit for flue 250mm/200.

□ BOILER PUMP CONTROL

The Gas 310/610 Eco Pro boilers have terminals, which can be used to connect an external boiler pump. This pump runs once every 24 hours to prevent sticking (24-hour pump operation).

Two options are available:

1. System pump connect to pump terminals on PCU – 06 max 300VA
2. Shunt pump connect to terminal on PCU – S05 plug x 03 max 300VA.

□ INSTALLATION SHUTDOWN

If the central heating system is not used for a long period, we recommend switching the boiler off.

- Switch the on/off switch to off
- Switch off the boiler electrical power supply
- Shut off the gas supply
- Ensure that the boiler and system are protected against frost damage.

CAUTION: In the event of low temperatures, we recommend that the installation continues to operate at a lower temperature. This prevents freezing.

□ FROST PROTECTION

CAUTION: Drain the boiler and central heating system if you are not going to use the building for a long time and there is a chance of frost.

For shorter periods: if there is no demand for heat, the boiler will only switch on in order to prevent frost damage. When the heating water temperature in the boiler falls by too much, the integrated protection system in the boiler starts up. This protection functions as follows:

- The circulation pump switches on if the water temperature is lower than 7°C (if pump is electrically connected to the boiler)
- If the water temperature is lower than 4°C, the boiler starts up
- If the water temperature is higher than 10°C, the boiler shuts down and the heating pump continues to run for a short time.

CAUTION: The integrated protection system only protects the boiler, not the installation.

BOILER CONTROLS

The Gas 310/610 Eco Pro boilers can be controlled using one of the following methods:

Note: This applies to each module on the Gas 610 Eco Pro.

□ ON/OFF CONTROL

GAS 310 ECO PRO

(One x NO VOLT FREE SWITCHED PAIR)

The heat output modulates between the minimum and the maximum value based on the set flow temperature, connected to ON/OFF – OT on PCU-06.

GAS 610 ECO PRO (TWO SETS)

(Two x NO VOLT FREE SWITCHED PAIR)

The heat output modulates between the minimum and the maximum value based on the set flow temperature, connected to ON/OFF – OT on PCU-06.

□ MODULATING

Fully modulating, where the output modulates between the minimum and maximum value on the basis of the flow temperature defined by the modulating controller.

Note: When using on/off control the boiler will also modulate to maintain the flow temp set point.

- Analogue control (0-10 volts), where the heat output or temperature is controlled by a 0-10 volt signal.
- ON/OFF control, (one volt free relay) where the heat output modulates between the minimum and maximum value on the basis of the flow temperature set in the boiler. In all cases, modulation is based on the required flow temperature and there is a Δt dependent output control with the following characteristic. Up to a Δt of 10 to 30°C (factory setting, parameter P45) the boiler operates at full capacity. Between Δt full load and Δt part load the output reduces in linear fashion.

MODULATING CONTROLS GENERAL (TWO WIRE CONTROL)

To make full use of the boiler's modulating feature, iSense controls can be connected. These controls will provide optimised time and weather compensation to achieve maximum efficiency and minimum boiler cycling whilst maintaining design conditions within the building.

Single and multiple optimising/weather compensating boiler controls are available for one or multiple boilers (up to a max of eight x Gas 310 Eco Pro or four x Gas 610 Eco Pro).

These compensators can regulate the boiler output against outside weather conditions and provide time and temperature control over the direct hot water (DHW).

The compensator is mounted in one of the boilers and is interfaced to communicate with the boiler's controls via the supplied adapter.

On-site connection of the supplied outside and common flow sensors completes the installation.

Note: Please refer to the relevant control leaflet for optimising/compensation settings.

□ ANALOGUE INPUT (0-10)

The function of the analogue input can be set using parameter P 3 7. This control can be based on temperature or heat output. If this input is used for 0-10 V control, then the boiler OT communication is ignored.

ANALOGUE TEMPERATURE-BASED CONTROL (°C)

The 0-10 V signal controls the boiler flow temperature. This control modulates on the basis of flow temperature, whereby the heat output varies between the minimum and maximum values on the basis of the flow temperature set point calculated by the controller.

INPUT SIGNAL (V)	TEMP °C	DESCRIPTION
0-1.5	0-15	Boiler off
1.5-1.8	15-18	Hysteresis
1.8-10	18-100	Temperature required

ANALOGUE HEAT OUTPUT-BASED CONTROL (%)

The 0-10 V signal controls the boiler output. The minimum and maximum values are limited. The minimum output is linked to the boiler's modulation depth. The output varies between the minimum and maximum value on the basis of the value determined by the controller.

INPUT SIGNAL (V)	HEAT OUTPUT %	DESCRIPTION
0-2.0*	10-20	Boiler off
2.0-2.2*	20-22	Hysteresis
2.0-10*	20-100	Heat output supplied

*Dependent on the minimum modulation depth (set speeds, standard 20%)

□ ANALOGUE OUTPUT (0-10)

The function of the analogue output can be set using parameter P 3 6. An outgoing 0-10 V signal can be used either to report the supplied heat output or the supplied temperature. The speed of the system pump can be controlled with an outgoing 0-10 V signal (only possible if the pump is suitable for this).

CONTROL OF 0-10 V WILO SYSTEM PUMP

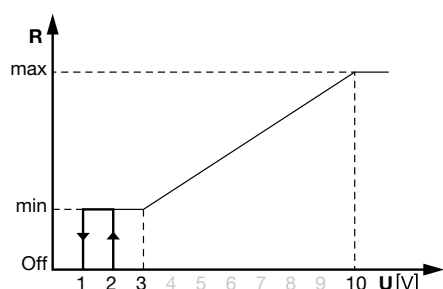

KEY

R	Pump speed
min	Minimum pump speed
max	Maximum pump speed
Off	The pump is off
U	Output signal (V)

OUTPUT SIGNAL (V)	DESCRIPTION
<1	Pump off
1-2	Hysteresis
2-3	Pump on (minimum pump speed)
3-10	Pump modulates (linear)

CONTROL OF PWM SYSTEM PUMP

In this case, the 0-10 V signal controls the system pump 1:1.

CONTROL OF 0-10 V GRUNDFOS SYSTEM PUMP

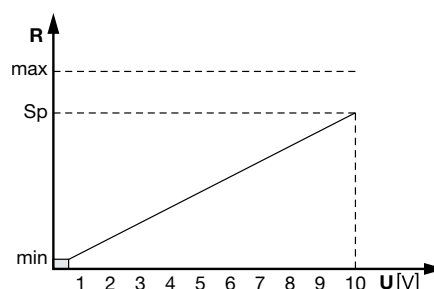

KEY

R	Pump speed
min	Minimum pump speed
max	Maximum pump speed
Sp	Normal set-point
U	Output signal (V)

OUTPUT SIGNAL (V)	DESCRIPTION
<0.5	Pump on (minimum pump speed)
>0.5	Pump modulates (linear)

MESSAGE ABOUT THE SUPPLIED HEAT OUTPUT

INPUT SIGNAL (V)	HEAT OUTPUT °C	DESCRIPTION
0	0	Boiler off
0.5	-	Blockage
2.0-10 ¹	20-100	Heat output supplied

MESSAGE ABOUT THE SUPPLIED TEMPERATURE

OUTPUT SIGNAL (V)	TEMP °C	DESCRIPTION
0.5	-	Blockage
1-10	10-100	Delivered temperature

GAS 310 ECO PRO

FLUE DATA

□ OPEN FLUE (B23, B23P)

If using an open version, the air supply opening remains open; only the combustion gas opening is connected. The boiler then takes in the combustion air required directly from the plant room in which it is installed. For the application of air discharge and combustion gas discharge flue with a diameter other than 250mm, a reducer should be used. If the boiler, in room ventilated operation, has been set up in a (very) dusty room, use the air supply filter (accessory).

CAUTION: The air supply opening must remain open. The premises in which the appliance is installed must be fitted with the necessary air supply openings. They must not be reduced or closed.

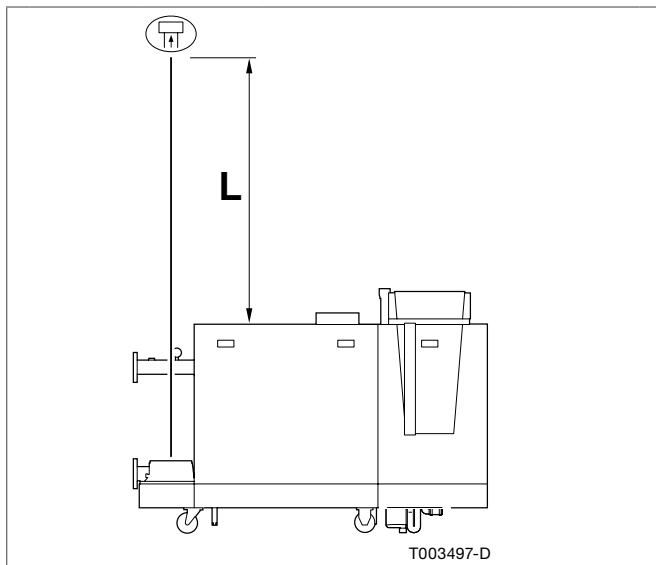

CHIMNEY LENGTH FOR THE OPEN VERSION – GAS 310 ECO PRO

BOILER TYPE	MAXIMUM LENGTH (L) ¹			
	WITH A Ø OF 150MM	WITH A Ø OF 180MM	WITH A Ø OF 200MM	WITH A Ø OF 250MM
310-285 (5)	20m	50m	50m	50m
310-355 (6)	11m	30m	50m	50m
310-430 (7)	8m	22m	39m	50m
310-500 (8)	7m	18m	32m	50m
310-575 (9)	5m	13m	24m	50m
310-650 (10)	5m	12m	21m	50m

PIPE REDUCTIONS PER ELEMENT USED

DIAMETER	ELBOW 45°	ELBOW 90°
150mm	1.2m	2.1m
180mm	1.4m	2.5m
200mm	1.6m	2.8m
250mm	2.4m	3.5m
300mm	2.4m	4.2m

¹Calculated with rigid pipe and outlet without hood (open 'free').

□ ROOM SEALED FLUE (C33, C63)

If using a room sealed version, it is necessary to connect both the combustion gas exhaust and the air supply opening (parallel). For the application of air discharge and combustion gas discharge piping with a diameter other than 250mm, a reducer should be used.

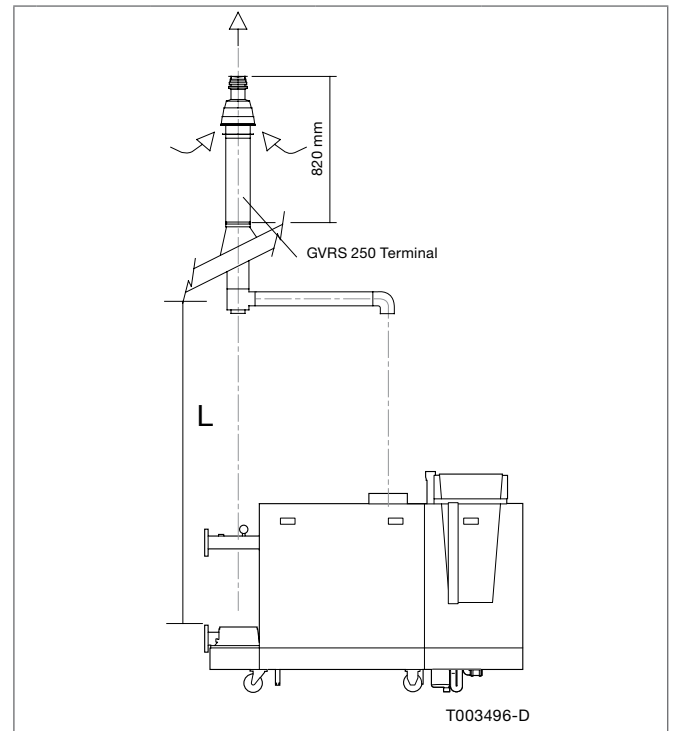

CHIMNEY LENGTH FOR THE ROOM-SEALED VERSION – GAS 310 ECO PRO

BOILER TYPE	MAXIMUM LENGTH (L) ¹		
	WITH A Ø OF 200MM	WITH A Ø OF 250MM	WITH A Ø OF 300MM
310-285 (5)	42m	50m	50m
310-355 (6)	21m	50m	50m
310-430 (7)	13m	50m	50m
310-500 (8)	10m	50m	50m
310-575 (9)	5m	34m	50m
310-650 (10)	4m	30m	50m

¹Calculated with rigid pipe and outlet without hood (open 'free').

GAS 610 ECO PRO FLUE DATA

CONNECTION IN AREAS OF DIFFERENT PRESSURE (C53, C83)

Combustion air supply and combustion gas discharge are possible in various pressure zones, semi-CLV systems, with the exception of coastal areas. The maximum permissible difference in height between the combustion air supply and the combustion gas discharge is 36m.

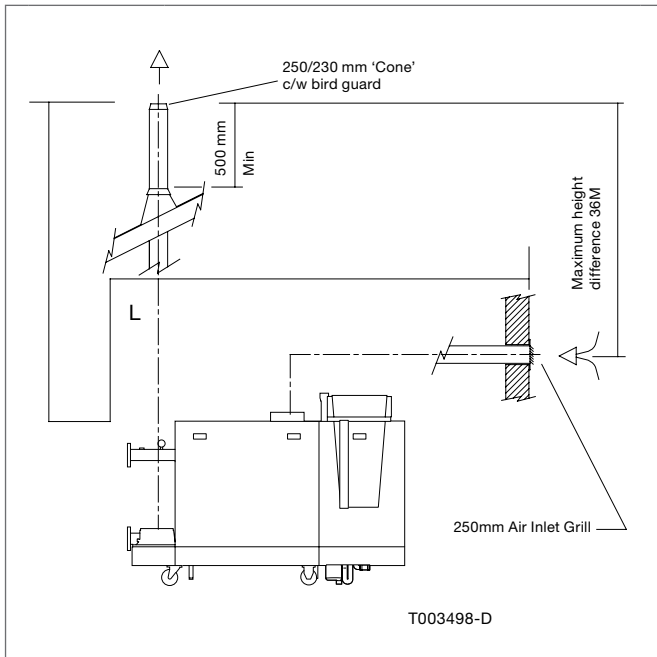

CHIMNEY LENGTH IN VARIOUS PRESSURE ZONES – GAS 310 ECO PRO	
BOILER TYPE	MAXIMUM LENGTH (L) ¹
	WITH A Ø OF 250MM
310-285 (5)	50m
310-355 (6)	50m
310-430 (7)	50m
310-500 (8)	50m
310-575 (9)	49m
310-650 (10)	40m

¹Calculated with rigid pipe and outlet without hood (open 'free').

OPEN FLUE (B23, B23P)

If using an open version, the air supply opening remains open; only the combustion gas opening is connected. The boiler then takes in the combustion air required directly from the premises in which it is installed. For the application of air discharge and combustion gas discharge and piping with a diameter other than 250mm, a reducer should be used. If the boiler, in room ventilated operation, has been set up in a (very) dusty room, use the air supply filter (accessory).

CAUTION: The air supply opening must remain open. The premises in which the appliance is installed must be fitted with the necessary air supply openings. They must not be reduced or closed.

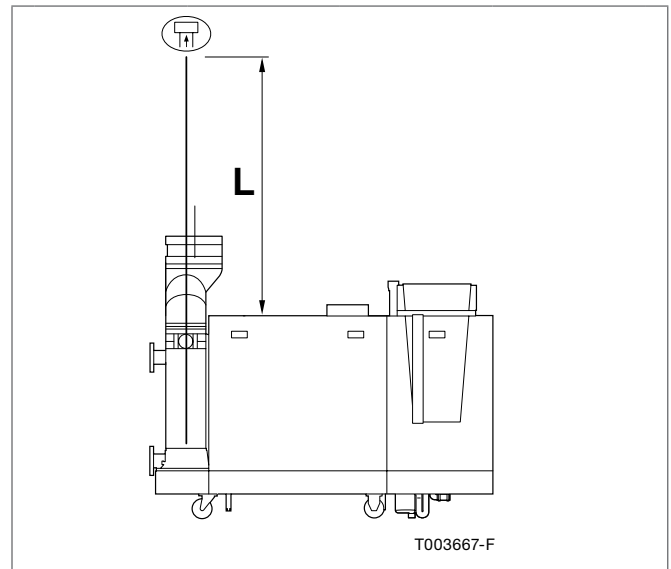

CHIMNEY LENGTH FOR THE OPEN VERSION – GAS 610 ECO PRO			
BOILER TYPE	MAXIMUM LENGTH (L) ¹		
	WITH A Ø OF 250MM	WITH A Ø OF 300MM	WITH A Ø OF 350MM
610-570 (5)	50m	50m	50m
610-710 (6)	31m	50m	50m
610-860 (7)	20m	50m	50m
610-1000 (8)	11m	39m	50m
610-1150 (9)	5m	26m	50m
610-1300 (10)	3m	19m	50m

PIPE REDUCTIONS PER ELEMENT USED		
DIAMETER	ELBOW 45°	ELBOW 90°
150mm	1.2m	2.1m
180mm	1.4m	2.5m
200mm	1.6m	2.8m
250mm	2.0m	3.5m
300mm	2.4m	4.2m
350mm	2.8m	4.9m
400mm	3.2m	5.6m

¹Calculated with rigid pipe and outlet without hood (open 'free').

GAS 610 ECO PRO

FLUE DATA

ROOM-SEALED FLUE (C33, C63)

If using a room-sealed version, it is necessary to connect both the combustion gas exhaust and the air supply opening separately. For the application of air discharge and combustion gas discharge and flue with a diameter other than 250mm, a reducer should be used.

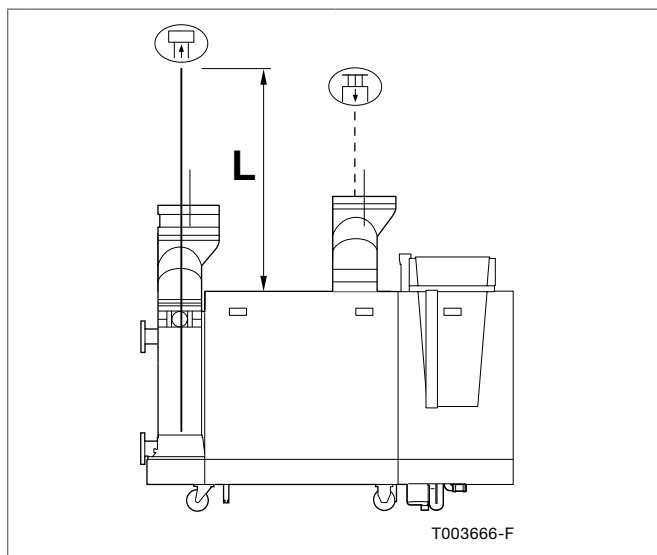

CHIMNEY LENGTH FOR THE ROOM SEALED VERSION – GAS 610 ECO PRO

BOILER TYPE	MAXIMUM LENGTH (L) ¹		
	WITH A Ø OF 300MM	WITH A Ø OF 350MM	WITH A Ø OF 400MM
610-570 (5)	50m	50m	50m
610-710 (6)	43m	50m	50m
610-860 (7)	26m	50m	50m
610-1000 (8)	13m	35m	50m
610-1150 (9)	5m	16m	24m
610-1300 (10)	-	10m	12m

¹Calculated with rigid pipe and outlet without hood (open 'free')

CONNECTION IN AREAS OF DIFFERENT PRESSURE (C53, C83)

Combustion air supply and combustion gas discharge are possible in various pressure zones, semi-CLV systems, with the exception of coastal areas. The maximum permissible difference in height between the combustion air supply and the combustion gas discharge is 36m.

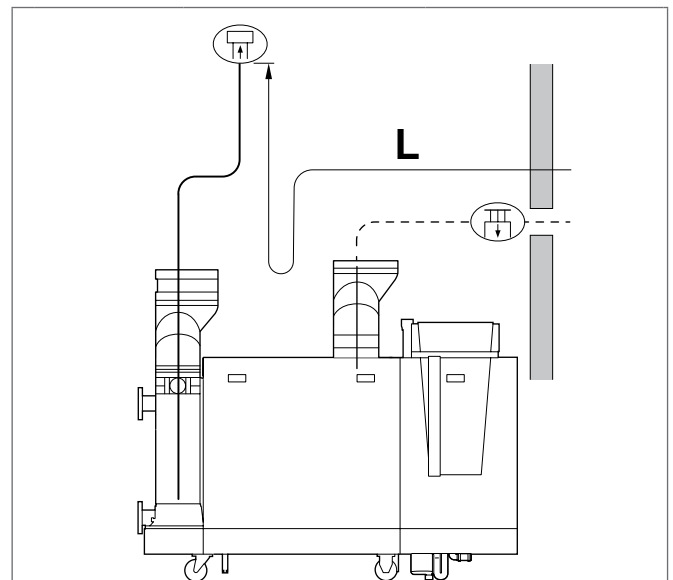

CHIMNEY LENGTH IN VARIOUS PRESSURE ZONES – GAS 610 ECO PRO

BOILER TYPE	MAXIMUM LENGTH (L) ¹	
	WITH A Ø OF 350MM	WITH A Ø OF 400MM
610-570 (5)	50m	50m
610-710 (6)	50m	50m
610-860 (7)	50m	50m
610-1000 (8)	33m	50m
610-1150 (9)	-	22m
610-1300 (10)	-	-

¹Calculated with rigid pipe and outlet without hood (open 'free')

Greater five lengths can be achieved.

Please contact the Remeha Commercial Technical Department.

TECHNICAL SUPPORT

From brochures to CAD drawings and BIM files, you can access all the information you need at remeha.co.uk.

Or call our sales or technical departments on **0118 978 3434**. We're always happy to help.

We can provide you with:

- Brochures
- Technical specification sheets
- Case studies
- Installation manuals
- BIM files
- CAD files
- Energy-related Products Directive data
- Commissioning
- Technical information
- Spare parts (after sales).

DECLARATION OF COMPLIANCE

We hereby certify that the series of appliances specified herein is in compliance with the standard model described in the EC declaration of compliance, and that it is manufactured and marketed in compliance with the requirements and standards of the following European Directives.

- 90/396/EEC Gas Appliances Directive
- 92/42/EEC Efficiency Directive
- 89/336/EEC E.M.C. Directive.

And complies with the following requirements:

- 73/23/EEC Electrical Low Voltage Directive
- 97/23/EEC Pressure Equipment Directive

Article 3, Sub.3

CE Certification

Reference number 0085BS0132

NO_x – Reference Number BS004

ErP Compliant

The unit has been inspected for compliance with the essential requirements of the following directives:
CE identification number (PIN): 0063CL3613

NO_x Class: 5.

Innovation House
3 Oaklands Business Centre
Oaklands Park
Wokingham RG41 2FD

T 0118 978 3434

E info@remeha.co.uk

W remeha.co.uk

A Baxi Heating Brand

Registered address: Baxi Heating UK Ltd Brooks House Coventry Road Warwick CV34 4LL

Printed October 2016



remeha

ENGINEERING EFFICIENCY SINCE 1935