

## P 320



## Installation and Service Manual

# Declaration of conformity

The appliance complies with the standard model described in declaration of compliance . It is manufactured and distributed pursuant to the requirements of european directives. The original of the declaration of compliance is available from the manufacturer.

**DÉCLARATION DE CONFORMITÉ CE  
EG - VERKLARING VAN OVEREENSTEMMING  
EC - DECLARATION OF CONFORMITY  
EG - KONFORMITÄT SERKLÄRUNG**

Fabricant/Manufacturer/Hersteller/Fabrikant : REMEHA B.V  
Adresse/Adress/Adress : Kanal Zuid 110  
Ville, pays Stad, Land/City, Country/Land, Ort : NL 7332 BD APELDOORN  
Tel : +31 55 549 69 69  
Fax : +31 55 549 64 96

déclare ici que les produit(s) suivant(s) : P 320  
verklaart hiermede dat de toestel(len) : 4, 5, 6, 7, 8, 9 éléments  
this is to declare that the following product(s)  
erklärt hiermit das die Produk(te)

Mise en circulation par : voir fin de notice

répond/répondent aux directives CEE suivantes:  
voldoet/voldoen aan de bepalingen van de onderstaande EEG-richtlijnen:  
is/are in conformity with the following EEC-directives:  
den Bestimmungen der nachfolgenden EG-Richtlinien entspricht/entsprechen:

CEE-Directive:	92/42/CEE	normes appliquées, toegepaste normen:
EEG-Richtlijn:	92/42/EEG	tested and examined to the following norms:
EEC-Directive:	92/42/EEC	verwendete Normen:
EG-Richtlinie:	92/42/EWG	EN 303.2(1999), EN 304(1993)
	90/396/CEE	EN 303.3 (1999)
	90/396/EEG	
	90/396/EEC	
	90/396/EWG	
	73/23/CEE	DIN EN 50165(2001) EN 50165 (1997+A1:2001)
	73/23/EEG	DIN EN 60335-1(2003), EN 60335-1(2002)
	73/23/EEC	
	73/23/EWG	
	89/336/CEE	EN 55014-1(2000+A1:2001)
	89/336/EEG	EN 55014-2(1997+A1:2001)
	89/336/EEC	EN 61000-3-2(2000),
	89/336/EWG	EN 61000-3-3(1995+A1:2001) EN55022 classe B (1998+A1 :2000)
	97/23/CEE	(art.3 section 3)
	97/23/EEG	(art. 3, lid 3)
	97/23/EEC	(article 3, sub 3)
	97/23/EWG	(Art. 3, Absatz 3)

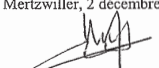

Mertzwiller, 2 décembre 2008

  
Jean-Claude GIRARDIN  
Directeur des opérations industrielles  
Recherche et développement

C001879-B

# Contents

---

<b>1</b>	<b>General</b> .....	<b>4</b>
<b>2</b>	<b>Description</b> .....	<b>5</b>
2.1	Technical specifications .....	6
2.2	Main dimensions .....	7
<b>3</b>	<b>Installing the boiler</b> .....	<b>8</b>
3.1	Boiler location .....	8
3.2	Ventilation .....	9
<b>4</b>	<b>Mounting</b> .....	<b>9</b>
<b>5</b>	<b>Hydraulic connections</b> .....	<b>10</b>
5.1	Important recommendations on connecting the heating circuit to the boiler and the drinking water system .....	10
5.2	Important recommendations for connecting the boiler to the heating circuit .....	11
5.3	Filling the system .....	12
5.4	Sludge removal .....	12
<b>6</b>	<b>Chimney connection</b> .....	<b>13</b>
6.1	Flue size .....	13
6.2	Chimney connection .....	13
<b>7</b>	<b>Fuel-oil or gas connections</b> .....	<b>14</b>
<b>8</b>	<b>Electrical connections</b> .....	<b>14</b>
<b>9</b>	<b>Maintenance</b> .....	<b>15</b>
9.1	Sweeping .....	15
9.2	Cleaning the casing material .....	16
9.3	Precautions required in the case of long boiler stops (one or more years) .....	16
9.4	Precautions required if the heating is stopped when there is a risk of freezing .....	16
<b>10</b>	<b>Burner maintenance</b> .....	<b>17</b>
<b>11</b>	<b>System maintenance</b> .....	<b>17</b>
11.1	Water level .....	17
11.2	Draining .....	17
<b>13</b>	<b>Spare parts</b> .....	<b>19</b>

# 1 General

This product will be marketed in the following European Union member states:

NL - BE - ES - GB - HU - SE

with a gas or oil-burner of the associated category.

## Directive 97/23/EC

Gas and oil boilers with a maximum operating temperature of 110°C and hot water tanks with a maximum operating pressure of 10 bar pertain to article 3.3 of the directive, and therefore, cannot be CE-marked to certify compliance with the directive 97/23 EC.



The boilers and hot water tanks are designed and manufactured in accordance with the sound engineering practice, as requested in article 3.3 of the directive 97/23/EC, it is certified by compliance with the directives 90/396/EC, 92/42/EC, 2006/95/EC and 2004/108/EC.

## Warning

The boiler shall be assembled and installed by a qualified professional only.

For a proper operating of the boiler, follow carefully the instructions.

## ■ Symbols used

	Caution danger	Risk of injury and damage to equipment. Attention must be paid to the warnings on safety of persons and equipment
	Specific information	Information must be kept in mind to maintain comfort
	Reference	Refer to another manual or other pages in this instruction manual

## 2 Description

---

The boilers of the P 320 range are pressurised hot water boilers designed for connecting to a flue pipe which require a separate automatic fuel-oil or gas burner.

The useful power of P 320 boilers is between 55 and 280 kW.

### Models available

Boiler with control panel, which may be fitted with an optional Rematic 2945 C3K control unit for heating only or heating and domestic hot water production.

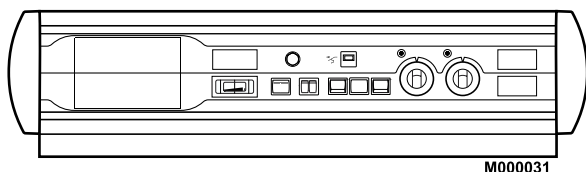

## 2.1 Technical specifications

Maximum operating pressure: 6 bar

Safety thermostat setting: 110 °C

Boiler thermostat setting: 30 to 90°C

Boiler			P 320-4	P 320-5	P 320-6	P 320-7	P 320-8	P 320-9
Useful output		<b>kW</b>	70-105	105-140	140-180	180-230	230-280	280-330
Power input		<b>kW</b>	76-117	115-156	153-199	197-253	252-309	305-361
Number of sections			4	5	6	7	8	9
Water content		<b>l</b>	96	116	136	156	176	196
Water resistance	$\Delta T = 15K^{(1)}$	<b>mbar</b>	6.2	10.9	20.4	30	44.5	63.8
Pressure in the furnace for nozzle pressure = 0		<b>mbar</b>	+0.3	+0.6	+1.1	+1.6	+2.2	+2.5
Flue gas temperature <sup>(1) (3)</sup>		<b>°C</b>	< 210	< 210	< 210	< 210	< 210	< 210
Mass flue gas flow rate <sup>(1)</sup>	Fuel oil	<b>Kg/h</b>	178	238	306	391	475	560
	Gas	<b>Kg/h</b>	187	250	321	410	499	588
Combustion chamber	Inscribed diameter	<b>mm</b>	377	377	377	377	377	377
	Depth	<b>mm</b>	621	781	941	1101	1261	1369
	Volume	<b>m<sup>3</sup></b>	0.096	0.122	0.148	0.174	0.200	0.226
Maintenance consumption	by 50°C	<b>%</b>	0.17	0.14	0.13	0.11	0.10	0.09
Shipping weight		<b>kg</b>	610	739	845	980	1101	1228

<sup>(1)</sup> Nominal operation (top boiler power)

<sup>(2)</sup> CO<sub>2</sub> = 13.1 to 13% with fuel oil and 9.5% with natural gas.

<sup>(3)</sup> Boiler temperature: 80 °C, Ambient temperature: 20 °C

 1 mbar = 10 mmWG = 10 daPa

 **In order for the boiler to operate correctly, it is imperative to respect the draught at the nozzle: 0 at the nozzle.**

## 2.2 Main dimensions

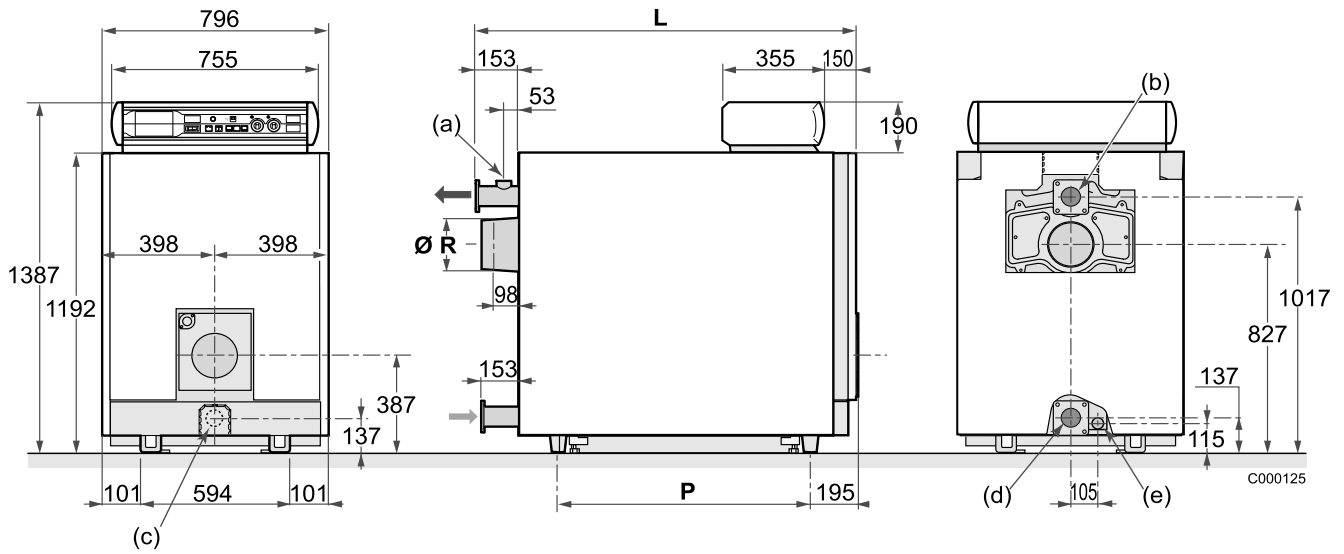

(a) Rp 1 1/2 socket for the safety control unit

(b) 2 1/2 heating outlet (flange + counter flange)

(c) Sludge removal hole  $\varnothing$  Rp 2 1/2

(d) 2 1/2 heating return (flange + counter flange)

(e) Rp 1 1/2 draining outlet (supplied with plug)

	P 320-4	P 320-5	P 320-6	P 320-7	P 320-8	P 320-9
L (mm)	991	1151	1311	1471	1631	1791
P (mm)	490	650	810	970	1130	1290
R (mm)	180	180	180	200	200	200

# 3 Installing the boiler

## 3.1 Boiler location

The P320 boiler does not require a special base for its assembly. Their closed furnace system means that the floor need not have refractory properties. All you have to ensure is that the floor can support the weight of the boiler when it is fitted for operation. If the boiler location is not determined precisely, leave enough space around the boiler to facilitate monitoring and maintenance operations.

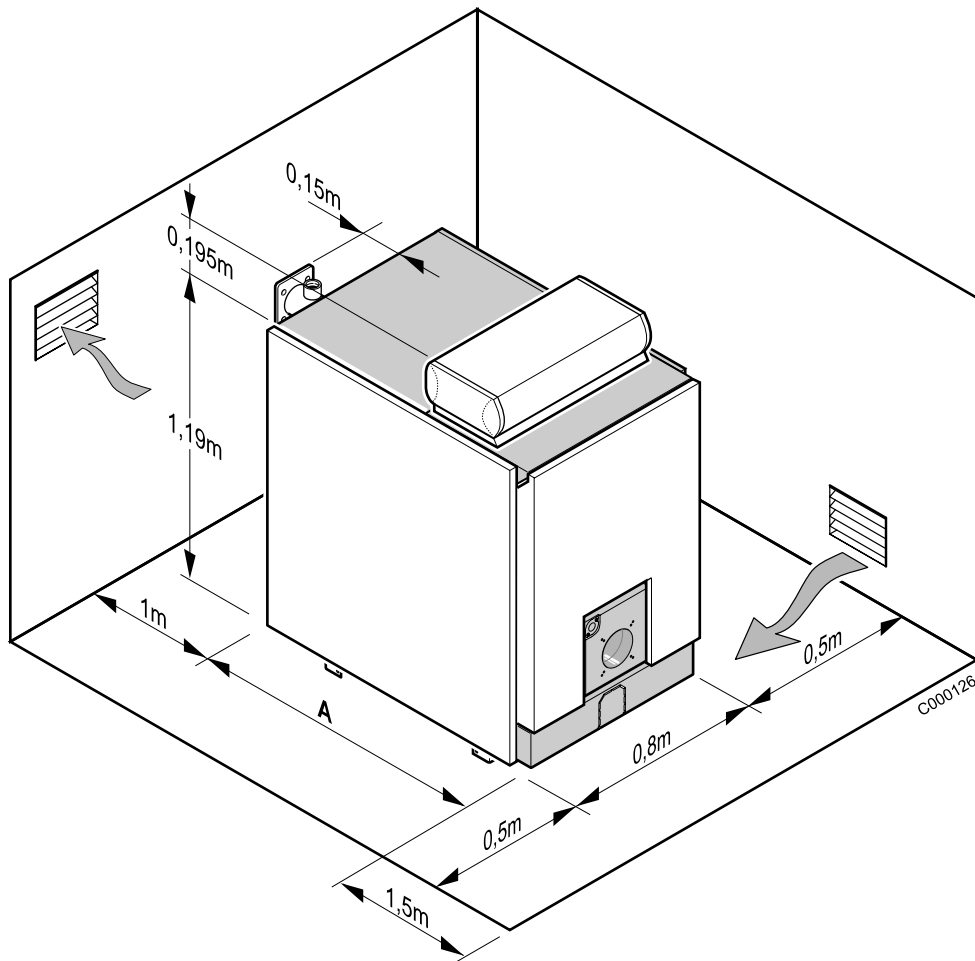

Boiler	P 320-4	P 320-5	P 320-6	P 320-7	P 320-8	P 320-9
A	838	998	1158	1318	1478	1638

**!** Pay attention to the overall volume of the burner when the door is open. To install several boilers in cascade, these dimensions should be adapted accordingly.



## 3.2 Ventilation

---

The location of air inlets in relation to the high ventilation openings shall ensure that the air is renewed in the entire volume of the boiler room.

It is in any case imperative to conform to the local regulations in force.

### **Caution:**

In order to avoid damage to the boiler, it is necessary to prevent the contamination of combustion air by chlorine and/or fluoride compounds, which are particularly corrosive.

These compounds are present, for example, in aerosol sprays, paints, solvents, cleaning products, washing products, detergents, glues, snow clearing salts, etc.

Therefore:

- Do not pull in air evacuated from premises using such products: hairdressing salons, dry cleaners, industrial premises (solvents), premises containing refrigeration systems (risk of refrigerant leakage), etc.
- Do not stock such products close to the boilers.

**If the boiler and/or peripheral equipment are corroded by such chloride or fluoride compounds, the contractual guarantee cannot be applied.**

## 4 Mounting

---

 For mounting instructions, see installation instructions.

# 5 Hydraulic connections

## 5.1 Important recommendations on connecting the heating circuit to the boiler and the drinking water system

Installation must be carried out in accordance with the prevailing regulations, the codes of practice and the recommendations in these instructions.

The expansion vessel must be connected directly to the boiler without valves or stop valves.

Likewise, the safety valve must be connected directly to the boiler without valves or stop valves.

### Example of an installation:

The example of an installation shown below does not cover every possible configuration. Its sole aim is to draw your attention to the basic rules to be respected. Comply at all times with the codes of practice and the prevailing national or local regulations.

P 320 boiler with domestic hot water production using an independent tank

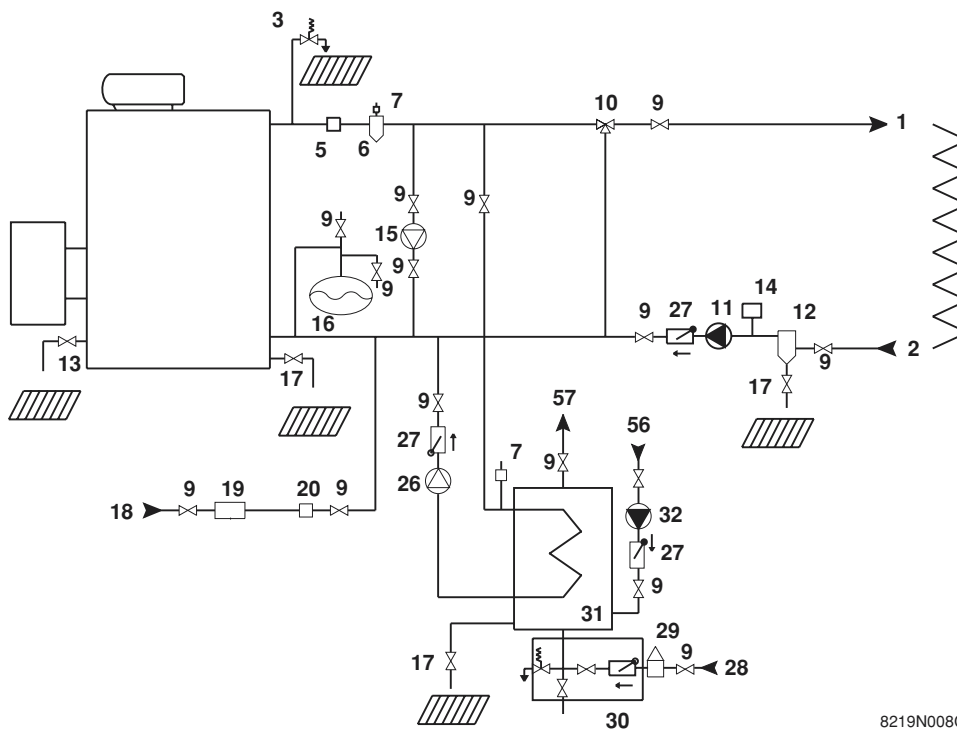

8219N008C

- |     |   |     |  |
|-----|---|-----|--|
| 1.  | Heating flow  | 28. | Domestic cold water inlet  |
| 2.  | Heating return  | 29. | Pressure reducer (if mains pressure 5.5 bar)                         |
| 3.  | 3 bar safety valve + manometer  | 30. | Sealed safety unit calibrated to 7 bar with indicator type discharge |
| 5.  | Flow switch   | 31. | Independent domestic hot water tanks                                 |
| 6.  | Air separator   | 32. | Domestic hot water loop pump (optional)                              |
| 7.  | Automatic air vent  | 56. | Domestic hot water circulation loop return                           |
| 9.  | Isolating valve   | 57. | Domestic hot water outlet  |
| 10. | 3-way mixing valve  |     |  |
| 11. | Boiler pump   |     |  |
| 12. | Sludge decanting pot (particularly recommended on older installations)          |     |  |
| 13. | Flush valve   |     |  |
| 14. | Water low safety pressure-sensitive switch                                      |     |  |
| 15. | Shunt pump  |     |  |
| 16. | Expansion vessel  |     |  |
| 17. | Drain cock  |     |  |
| 18. | Heating circuit filling (with disconnecter depending on prevailing regulations) |     |  |
| 19. | Water treatment if TH > 25°   |     |  |
| 20. | Water meter   |     |  |
| 26. | DHW load pump   |     |  |
| 27. | Non-return valve  |     |  |

## 5.2 Important recommendations for connecting the boiler to the heating circuit

Installation must be carried out in accordance with the prevailing regulations, the codes of practice and the recommendations in these instructions.

### ► Minimum safety valve flowrate as a function of maximum boiler nominal output:

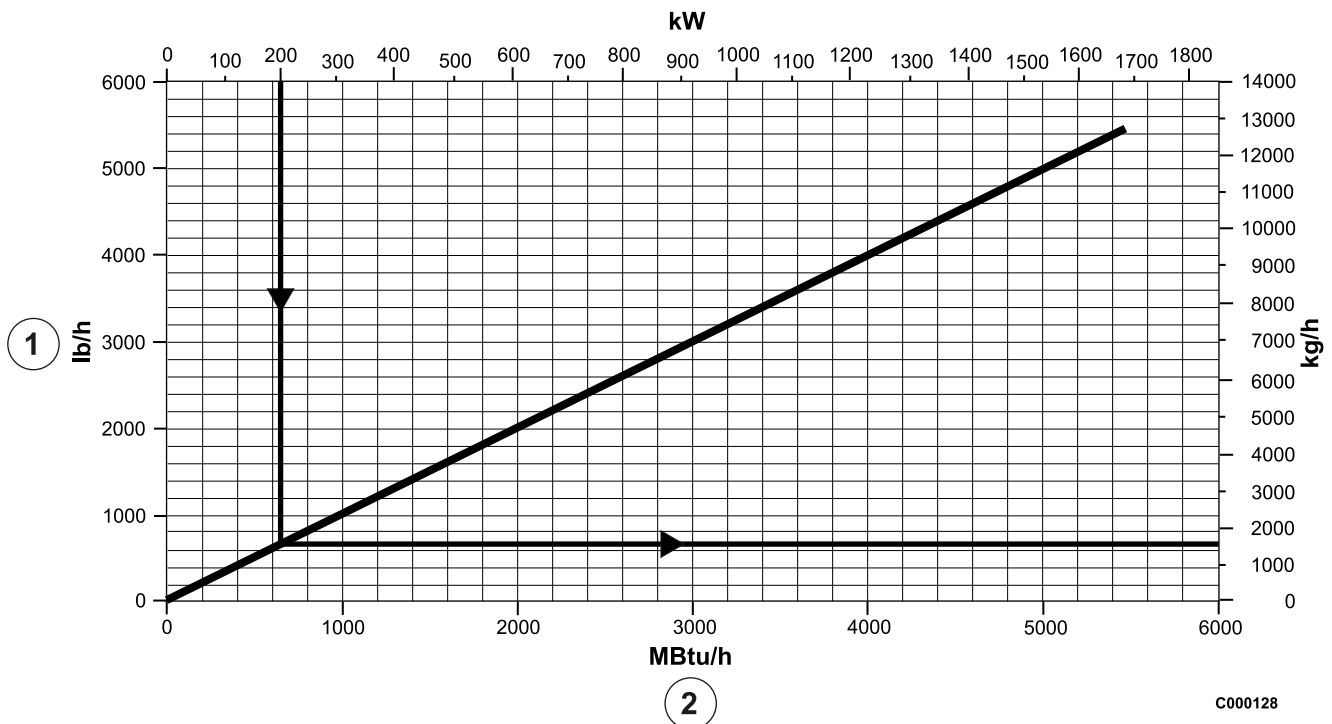

- ① Minimum relieving capacity
- ② Maximum gross boiler output

### Example

Maximum boiler nominal output is 200 kW.

Minimum safety valve flowrate must be 1500 Kg/h

### ► Water flow in the boiler :

The water flow in the boiler when the burner is operating must correspond with the following formulae:

- Nominal water flow  $Q_n = 0.86 P_n / 20$
- Minimum flow  $Q_{min} = 0.86 P_n / 45$  (this flow also corresponds with the minimum recycle flow in the boiler)
- Maximum water flow  $Q_{max} = 0.86 P_n / 5$

$Q_n$  = flow in  $m^3/h$

$P_n$  = Nominal output (full boiler output) in kW.

### ► Operation in cascade

After stopping the burner:

- Timeout required before the order to close a 2 way valve: 3 min
- Switch a possible shunt pump (located between the boiler and a butterfly valve) off via the end of run contact of the butterfly valve

### ► Operation with 2-stage burner

- The water temperature in the boiler is maintained at 50°C or more ; The first stage must be set to a minimum of 30% of the nominal stage
- Operation at modulated low temperature (minimum outlet temperature: 30°C) ; The first stage must be set to a minimum of 50% of the nominal stage

### ►Operation with modulating burner

- The water temperature in the boiler is maintained at 50°C or more: The burner can modulate down to 30% of the nominal stage
- Operation at modulated low temperature (minimum outlet temperature: 30°C) ; The burner can modulate down to 50% of the nominal stage

## 5.3 Filling the system

---

Filling shall be performed with a low flow rate from a low point in the boiler room in order to ensure that all the air in the boiler is bled from the high point of the system.

All the pumps must be stopped before filling (included shunt pump(s)).

 **VERY IMPORTANT: Instructions for starting up the boiler for the first time after the system is fully or partly drained: If all the air is not bled naturally to an expansion vessel which opens out onto the air, the system must include manual bleeder valves, in addition to automatic bleeder valves with the capability to bleed the system by themselves when it is operating, the manual bleeder valves are used to bleed all the high points of the system and to make sure that the filled system is free of air before the burner is turned on.**

 **Do not add cold water suddenly into the boiler when it is hot.**

## 5.4 Sludge removal

---

A tapped Ø 1" 1/2 hole with a plug has been provided on the bottom of the front of the boiler.. Fit a 1/4 turn valve (not supplied) on the opening to remove the sludge.

Sludge removal leads to the draining of large quantities of water, so remember to refill the system after the operation.

**Note:**

never replace a boiler in an existing system without carefully rinsing the system first. Install a sludge decanting pot on the return pipe, very close to the boiler.

# 6 Chimney connection

---

The high-performance features of modern boilers and their use in specific conditions as a result of the advance in burner technology (e.g. first-stage or low modulation range operation) lead to very low flue gas temperatures (<160°C).

For this reason:

- Use flue gas pipes designed to enable the flow of condensates which may result from such operating modes in order to prevent damage to the chimney.
- Install a draining tee at the bottom of the chimney.

The use of a draught moderator is recommended as well.

## 6.1 Flue size

---

Refer to applicable regulations while determining the size of the flue. Please note that P 320 boilers have pressurised and tight furnaces and that the pressure at the nozzle must not exceed 0 mbar, unless special sealing precautions have been taken, for instance in order to connect a static condenser/regenerator.

## 6.2 Chimney connection

---

The connection shall be removable, and offer minimum load losses, i.e. it must be as short as possible with no sudden change in section.

Its diameter shall always be at least equal to that of the boiler outlet, i.e.:

Ø 180 mm: for 4 to 6 sections

Ø 200 mm: for 7 to 9 sections

Fit a measuring point (Ø 10 mm hole) on the flue, in order to adjust the burner (combustion check).

# 7 Fuel-oil or gas connections

 Refer to the instructions supplied with the burner.

 The burner head deflector must be flush with the insulation of the burner door.

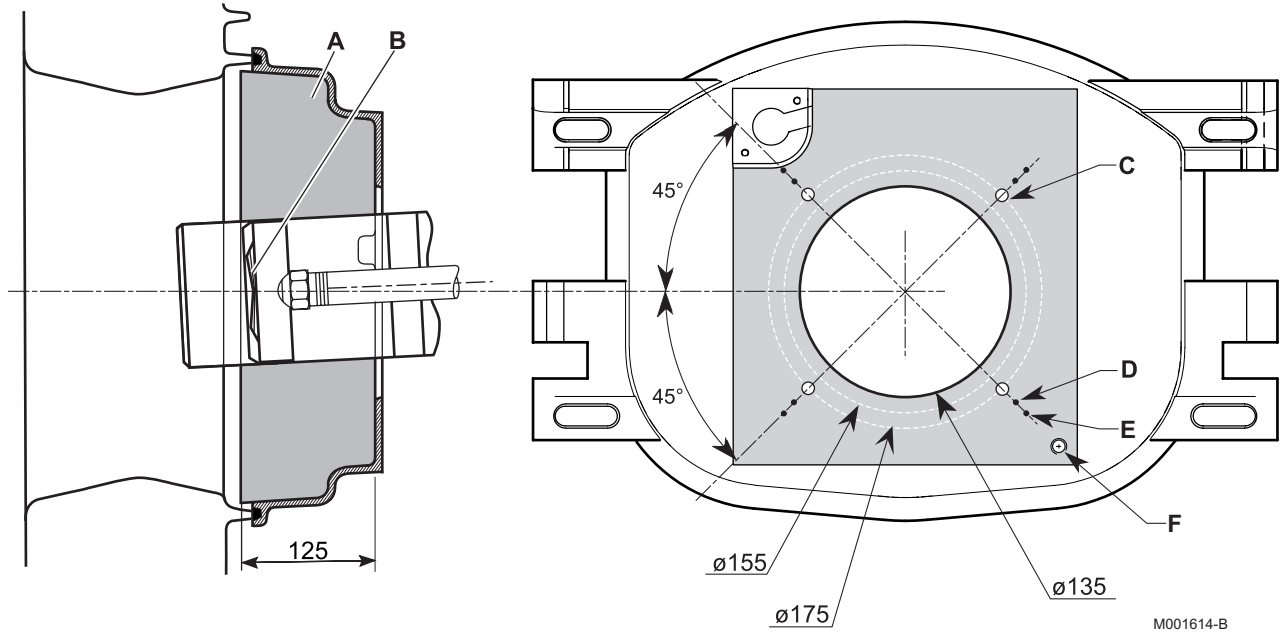

- A: Furnace door insulation
- B: Turbulator
- C: 4 markings on Ø 170
- D: 4 markings on Ø 200
- E: 4 markings on Ø 220

# 8 Electrical connections

 Refer to the connection instructions supplied with the control panel.

# 9 Maintenance

 The operations described below shall only be performed with the boiler and power supply off.

## 9.1 Sweeping

The boiler will only operate efficiently if the exchange surfaces are kept clean.

The boiler should be cleaned as soon as required and as the chimney, **at least once a year or more**, depending upon applicable regulations and specific needs.

### ■ Cleaning the flue gas circuit

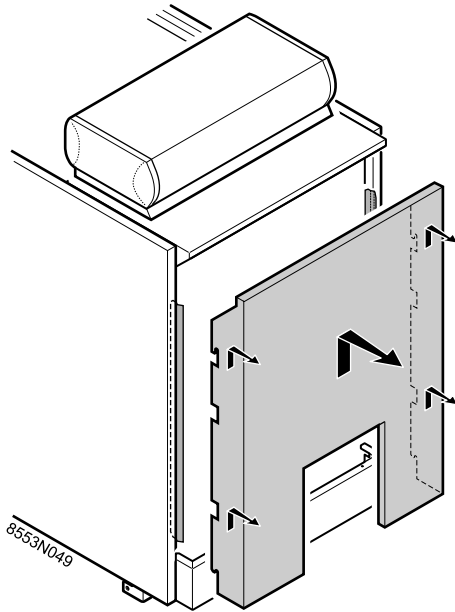

- Switch off the boiler electrical power supply.
- Unhook the front panel.
- Open the cleaning door (top door) by unscrewing the 4 closing nuts (17 mm spanner),
- Remove the baffle plates,
- Carefully sweep the flue ways with the brush supplied for that purpose,
- Also sweep the baffle plates and the front panel,
- If possible, use a vacuum cleaner,
- Replace the baffle plates,
- Close the door.

### ■ Cleaning the combustion chamber

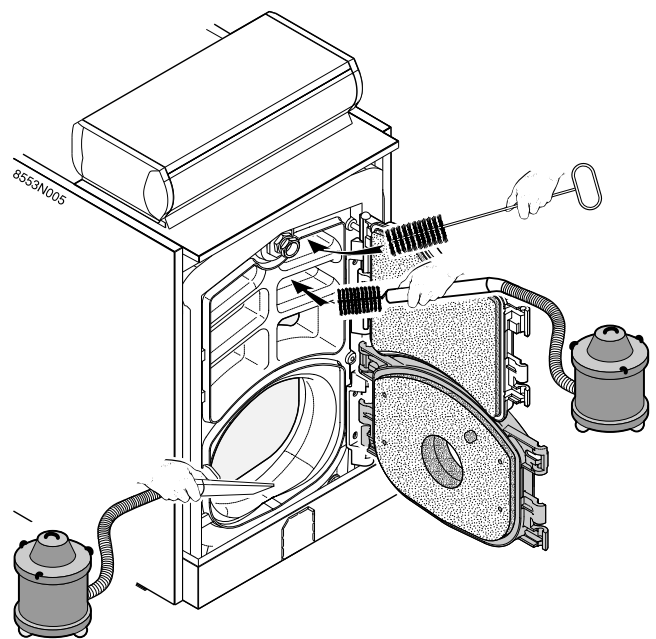

- Unscrew the 4 closing nuts and open the furnace door
- Brush out the inside of the furnace
- Use a vacuum cleaner to remove any soot which has accumulated in the combustion chamber
- Close the door and replace the front panel.

## ■ Positioning of the baffles

**!** The first two baffles on the two lower flue ways are fitted with stops to position them in the right place.

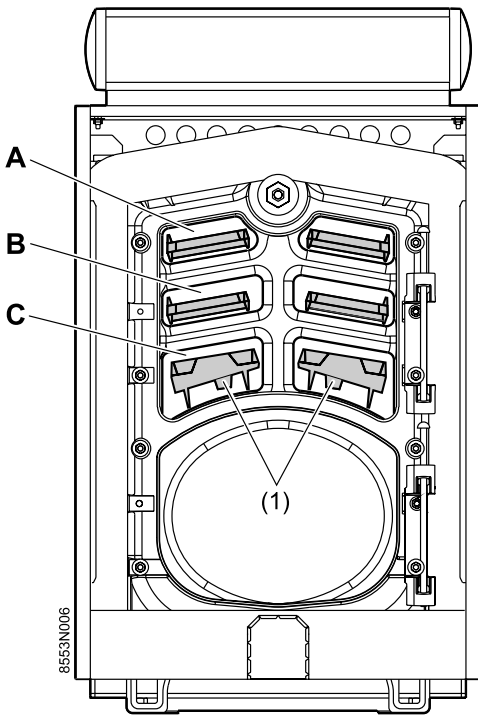

(1) Stop

## ■ Cleaning the flue gas box

- Remove the left and right cleaning hatches from the flue gas box (2 butterfly screws) and use a vacuum cleaner to remove any soot which has accumulated
- Replace the cleaning hatches.

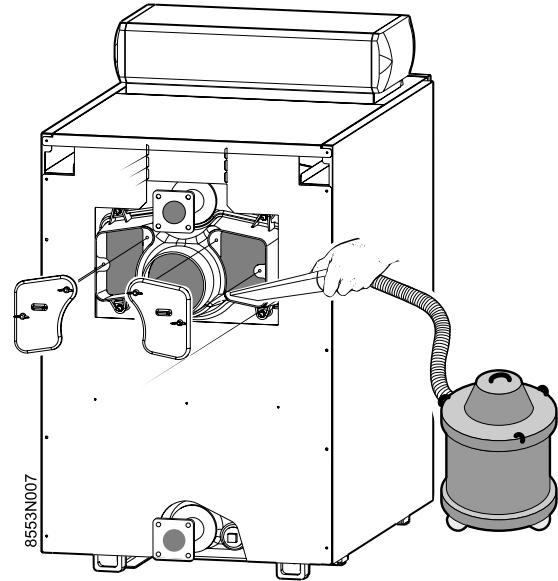

Baffle plates		Flue ways	P 320-4	P 320-5	P 320-6	P 320-7	P 320-8	P 320-9
upper	410 mm	A + B	-	8	8	-	-	-
	570 mm	A + B	4	-	-	4	4	4
interior	412 mm	C	2	2	2	2	2	2

## 9.2 Cleaning the casing material

Use a soapy solution and a sponge only. Rinse with clean water and dry with chamois leather or a soft cloth.

## 9.3 Precautions required in the case of long boiler stops (one or more years)

- The boiler and the chimney must be swept carefully.
- Close all the doors of the boiler to prevent air from circulating inside the boiler.
- We advise removing the pipe which connects the boiler to the chimney and to close off the nozzle with a cover.

## 9.4 Precautions required if the heating is stopped when there is a risk of freezing

We recommend the use of a correctly dosed antifreeze agent to prevent to the heating circuit from freezing. If this cannot be done, drain the system completely.



# 10 Burner maintenance

---

Refer to the instructions supplied with the burner.

# 11 System maintenance

---

## 11.1 Water level

---

Regularly check the level of water in the system and top up if required, taking care that cold water is not added suddenly into the boiler when it is hot.

This operation should be required only a few times in each heating season, with very low quantities of water; otherwise, look for the leak and repair it.

## 11.2 Draining

---

We advise you against draining the system unless it is absolutely necessary.

# 12 Data plate

The rating plate fixed on the side of the boiler during installation is used to identify the boiler correctly and also provides the main specifications of the boiler.

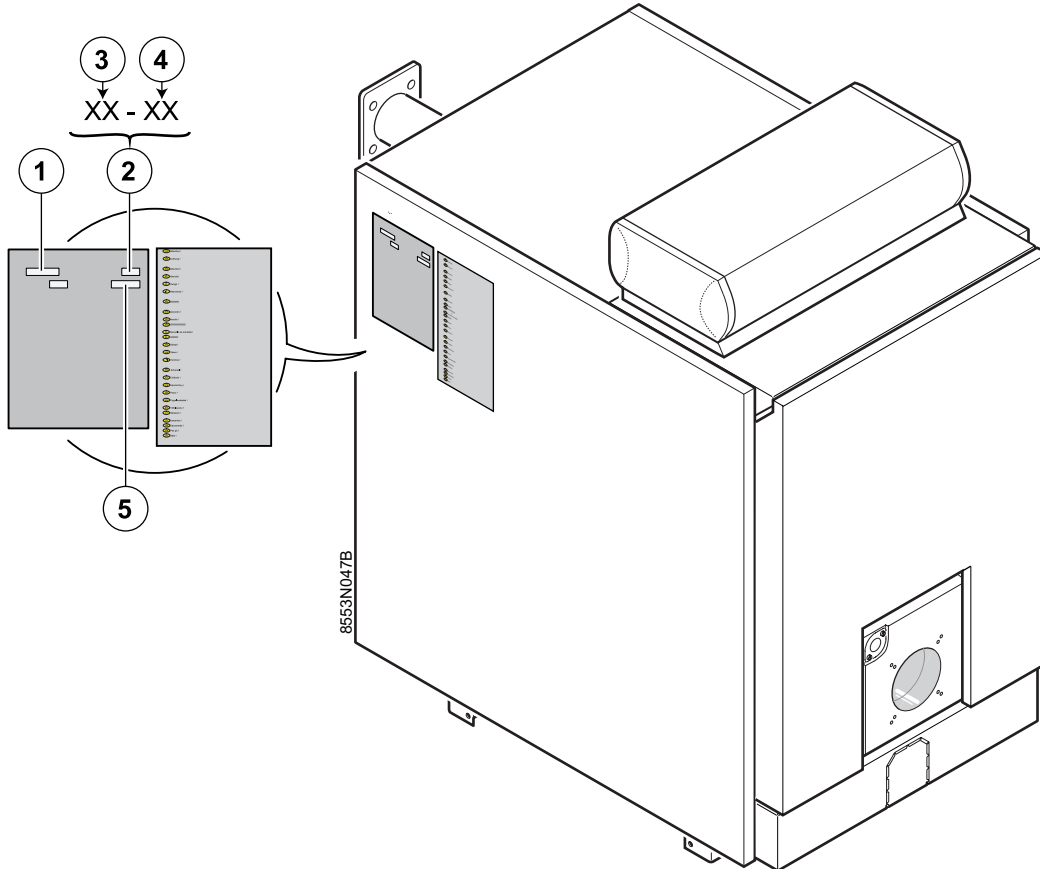

- ① Boiler type
- ② Manufacturing date
- ③ Year of manufacture
- ④ Week of manufacture
- ⑤ Serial no. of the appliance

# 13 Spare parts

**i** To order a spare part, quote the reference number next to the part required.

20/09/2011 - 300016243-002-C

## Boiler body

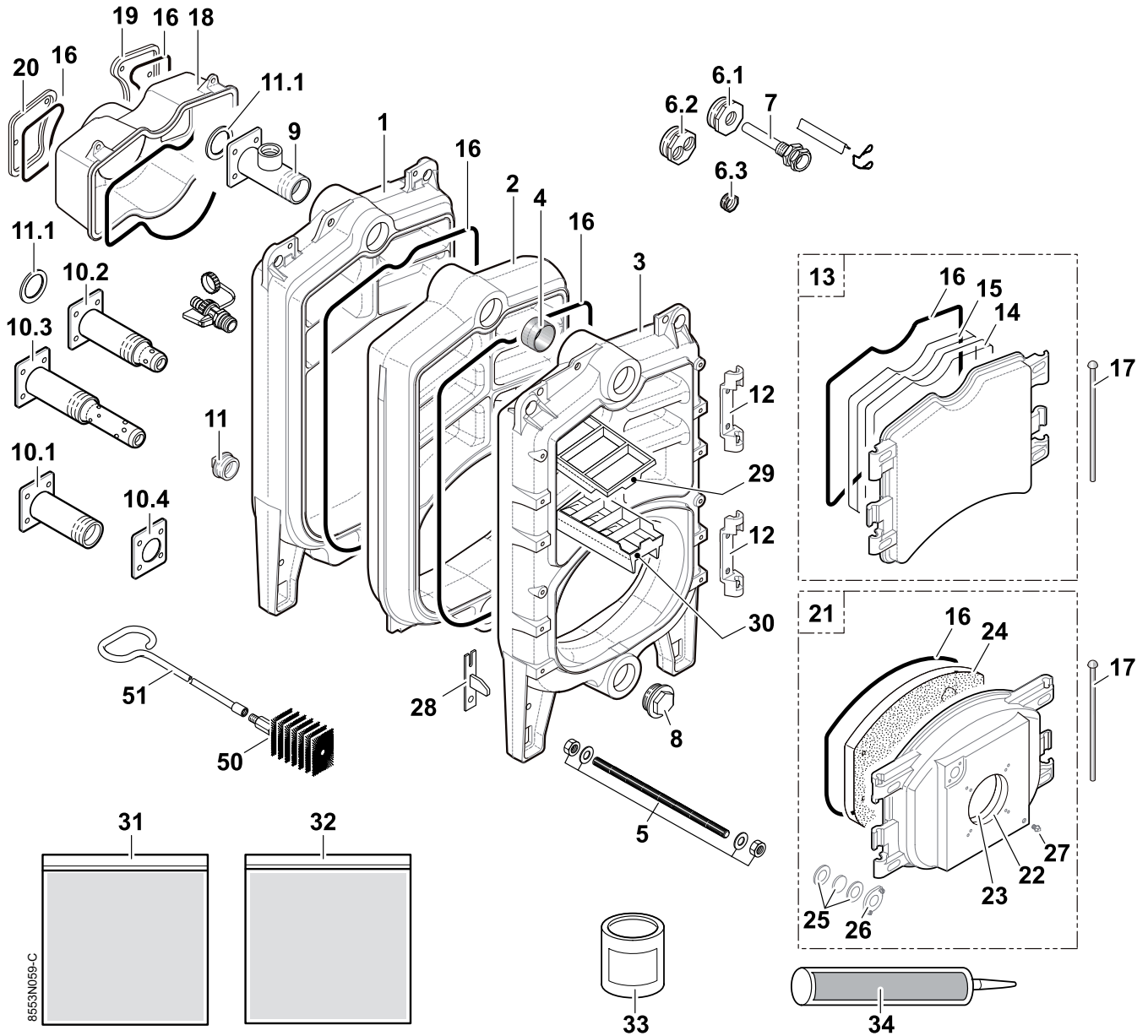

8553N059-C

## Insulation

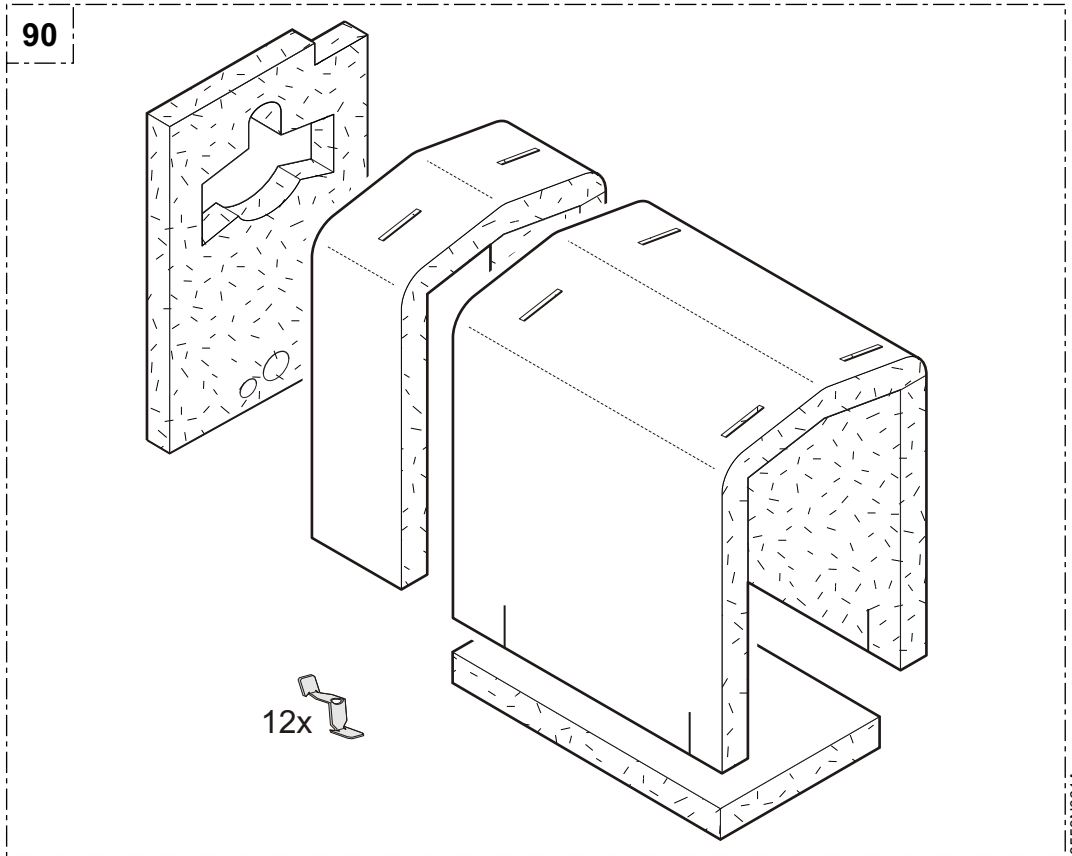

## Base frame

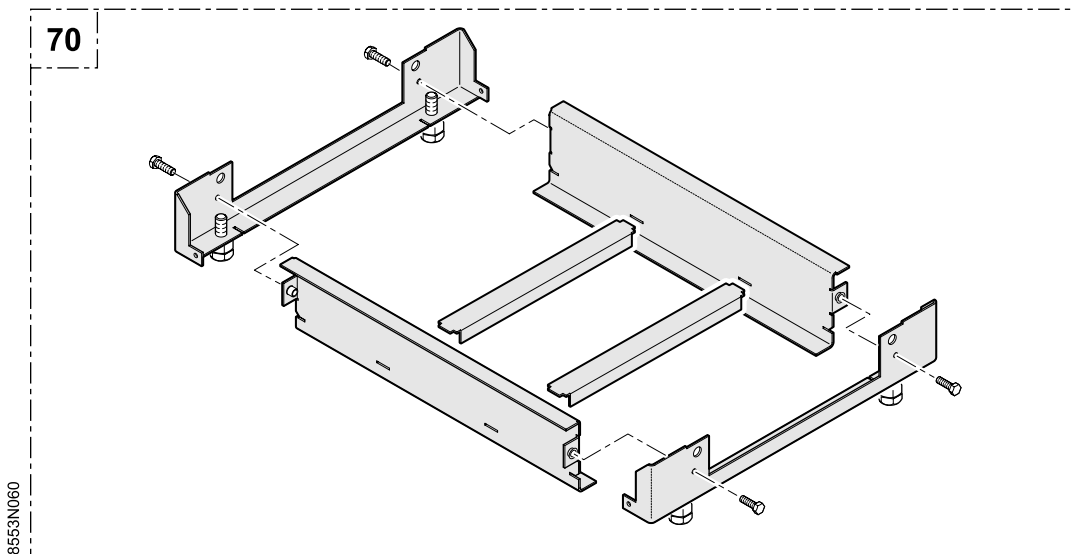

Casing - before week 14 / 2008

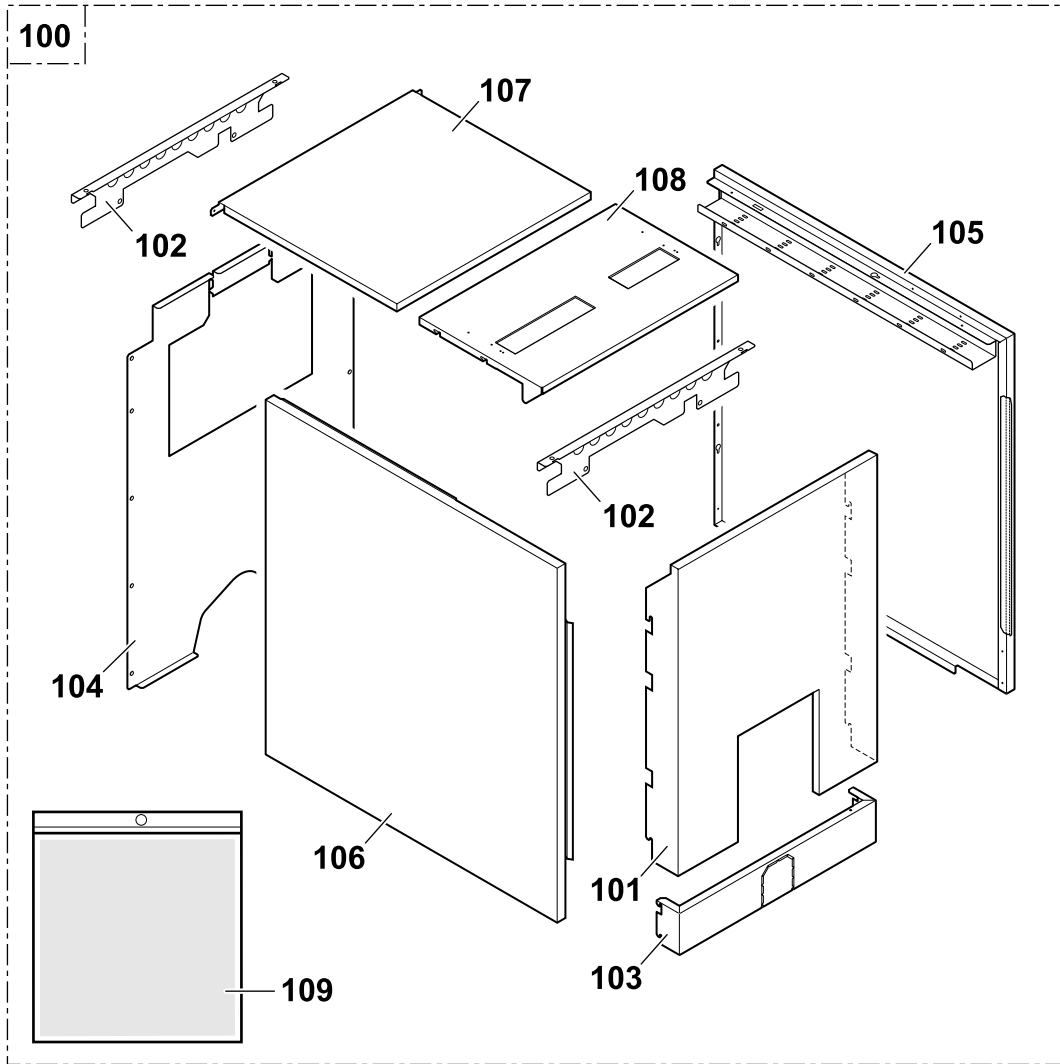

Casing - after week 14 / 2008

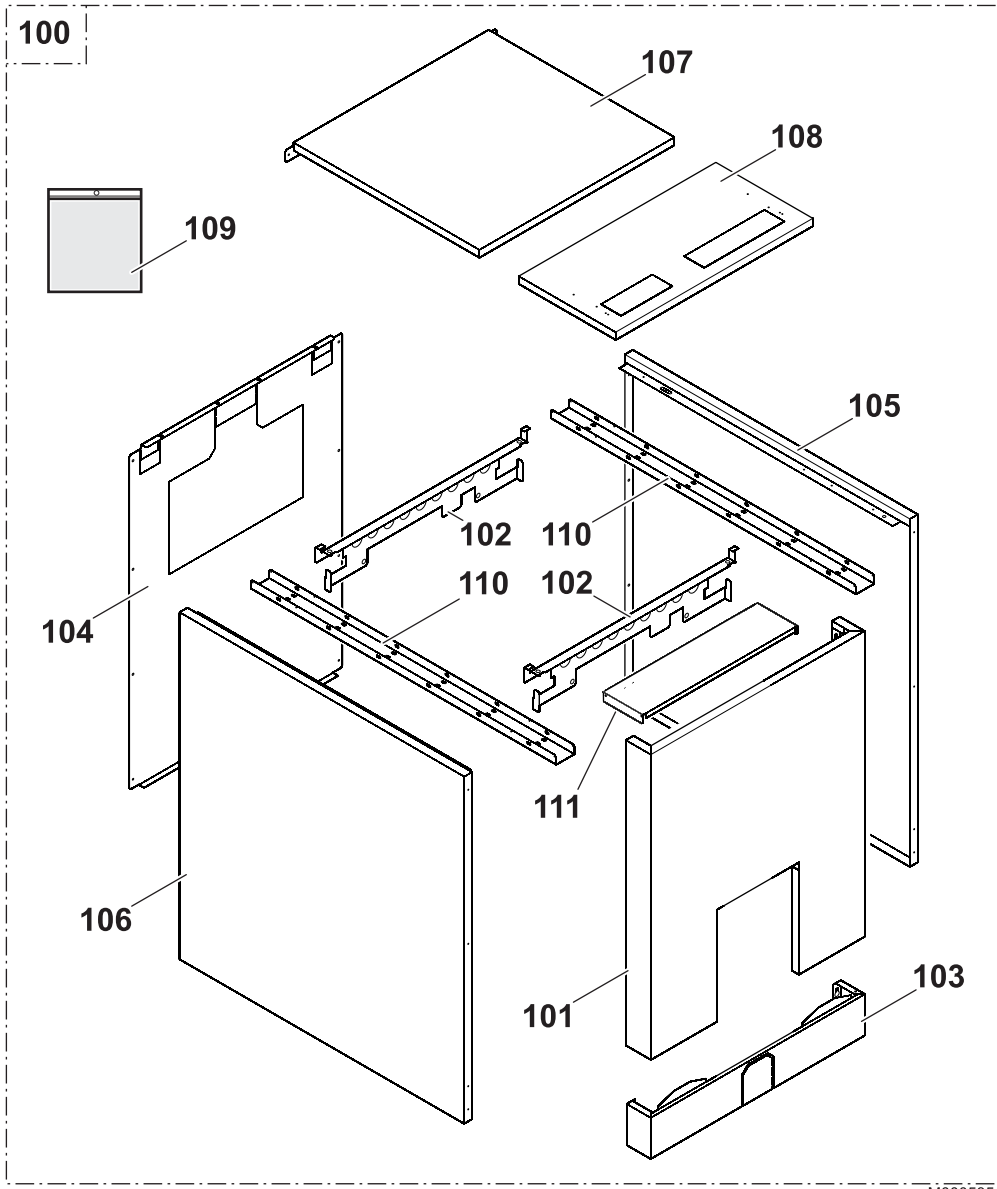

M000535A

Table - RC 6

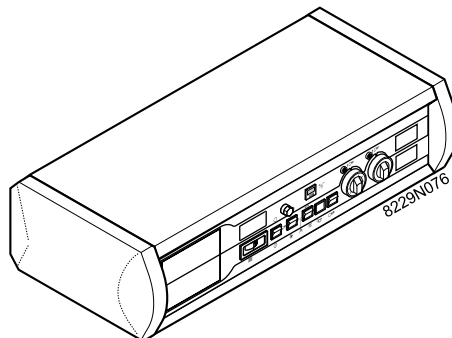

Markers	Code no.	Description
		<b>Boiler body</b>
1	8219-8912	Complete rear section
2	8219-8966	Special intermediate section
3	8219-8976	Complete front section
4	8116-0571	Nipple
5	8219-8968	Complete assembly rod, 4 sections
5	8219-8969	Complete assembly rod, 5 sections
5	8219-8970	Complete assembly rod, 6 sections
5	8219-8971	Complete assembly rod, 7 sections
5	8219-8972	Complete assembly rod, 8 sections
5	8219-8973	Complete assembly rod, 9 sections
6.1	8202-0028	Plug 2 1/2" - 1/2"
6.2	8209-0049	Plug 2 1/2" - 1/2" - NL
6.3	9494-8080	Nipple N 241 - 1/2"x1/4"
7	9536-5611	Rp 1/2 sensor tube
8	8013-0028	Solid plug 2" 1/2
9	8553-5513	Flow flange, 3 to 9 sections
10.1	8553-5514	Return flange, 4 to 5 sections
10.2	8553-5515	Return flange + distribution pipe, 6 to 8 sections
10.3	8553-5516	Return flange + distribution pipe, 9 sections
10.4	9754-9178	Counter flange
11	9495-0249	Male plug 290 T9 - R 1 1/2
11.1	9501-4122	Flange gasket
12	8104-8984	Hinge
13	8219-8916	Sweeping door
14	9425-0306	Inner protection, sweeping door
15	9425-0305	Insulation, sweeping door
16	9508-6032	10 Ø thermocord gasket
17	9756-0203	Pin Ø 12x350
18	8219-8913	Ø 180 complete nozzle
18	8219-8914	Ø 200 complete nozzle
19	8219-0206	Right hand nozzle cover
20	8219-0207	Left hand nozzle cover
21	8219-8953	Complete combustion chamber door, ø 135
22	9425-0303	Internal protection, combustion chamber door
23	9425-0302	Furnace door guard
24	9425-0301	Furnace door insulation
25	8015-7700	Sight glass + gaskets
26	9757-0027	Inspection flange
27	9495-0050	Plug 1/4"
28	8219-0539	Guide rail for combustion chamber door
29	8219-0017	Upper baffle plate, 410 mm
29	8219-0018	Upper baffle plate, 570 mm

Markers	Code no.	Description
30	8219-0019	Lower baffle plate, 412 mm
30	8219-0020	Lower baffle plate, 572 mm
31	8219-7724	Body screws packet
32	8219-8957	Bag of screws for furnace door
33	9430-5027	0.3 kg can nipple lubricant
34	9432-0214	Mastic Novasil S 17
		<b>Miscellaneous</b>
50	9750-5025	Brush
51	9750-5076	1000 mm brush rod
51	9750-5060	1300 mm brush rod
		<b>Base frame</b>
70	8553-7060	Complete frame 4 sections Package FD 30
70	8553-7061	Complete frame 5 sections Package FD 31
70	8553-7062	Complete frame 6 sections Package FD 32
70	8553-7063	Complete frame 7 sections Package FD 33
70	8553-7064	Complete frame 8 sections Package FD 34
70	8553-7065	Complete frame 9 sections Package FD 35
		<b>Insulation</b>
90	8553-5507	Complete boiler body insulation, 4 sections
90	8553-5508	Complete boiler body insulation, 5 sections
90	8553-5509	Complete boiler body insulation, 6 sections
90	8553-5510	Complete boiler body insulation, 7 sections
90	8553-5511	Complete boiler body insulation, 8 sections
90	8953-5512	Complete boiler body insulation, 9 sections
		<b>Casing - after week 14 / 2008</b>
100	100004865	Complete casing 4 sections
100	100004866	Complete casing 5
100	100004867	Complete casing 6
100	100004868	Complete casing 7
100	100004869	Complete casing 8
100	100004880	Complete casing 9
101	200013020	Front panel
102	200004840	Upper crosspiece
103	200004839	Lower cap
104	200005032	Complete rear panel
105	200005033	Complete side panel right, 4 sections
105	200005034	Complete side panel right, 5 sections

<b>Markers</b>	<b>Code no.</b>	<b>Description</b>
105	200005035	Complete side panel right, 6 sections
105	200005036	Complete side panel right, 7 sections
105	200005037	Complete side panel right, 8 sections
105	200005038	Complete side panel right, 9 sections
106	200005039	Complete side panel left, 4 sections
106	200005040	Complete side panel left, 5 sections
106	200005041	Complete side panel left, 6 sections
106	200005042	Complete side panel left, 7 sections
106	200005043	Complete side panel left, 8 sections
106	200005044	Complete side panel left, 9 sections
107	200004830	Complete rear cover, 4 sections
107	200004831	Complete rear cover, 5 sections
107	200004832	Complete rear cover, 6 sections
107	200004833	Complete rear cover, 7 sections
107	200004834	Complete rear cover, 8 sections
107	200004835	Complete rear cover, 9 sections
108	200005045	Complete front cover
109	200005046	Screw bag
110	200004849	4-section cable way
110	200004850	5-section cable way
110	200004851	6-section cable way
110	200004852	7-section cable way
110	200004853	8-section cable way
110	200004854	9-section cable way
111	200004841	Cable protection
<b>Casing - before week 14 / 2008</b>		
100	100003501	Complete casing 4 sections
100	100003502	Complete casing 5
100	100003503	Complete casing 6
100	100003504	Complete casing 7
100	100003505	Complete casing 8
100	100003506	Complete casing 9
101	200003545	Front panel
102	8553-8000	Upper crosspiece
103	8553-5506	Lower cap
104	8553-8519	Complete rear panel
105	8553-8545	Complete side panel right, 4 sections
105	8553-8546	Complete side panel right, 5 sections
105	8553-8547	Complete side panel right, 6 sections
105	8553-8548	Complete side panel right, 7 sections
105	8553-8549	Complete side panel right, 8 sections
105	8553-8550	Complete side panel right, 9 sections
106	8553-8551	Complete side panel left, 4 sections
106	8553-8552	Complete side panel left, 5 sections

<b>Markers</b>	<b>Code no.</b>	<b>Description</b>
106	8553-8553	Complete side panel left, 6 sections
106	8553-8554	Complete side panel left, 7 sections
106	8553-8555	Complete side panel left, 8 sections
106	8553-8556	Complete side panel left, 9 sections
107	8553-8512	Complete rear cover, 4 sections
107	8553-8513	Complete rear cover, 5 sections
107	8553-8514	Complete rear cover, 6 sections
107	8553-8515	Complete rear cover, 7 sections
107	8553-8516	Complete rear cover, 8 sections
107	8553-8517	Complete rear cover, 9 sections
108	8553-8518	Complete front cover
109	8553-8520	Screw bag - Casing
		<b>K - RC 6 control panel</b>
		Refer to the Spare Parts list in the panel instructions.









- NL Remeha B.V.**  
Postbus 32  
7300 AA APELDOORN  
Tel: +31 55 5496969  
Fax: +31 55 5496496  
Internet: nl.remeha.com  
E-mail: remeha@remeha.com
- B J.L. Mampaey BVBA**  
Uitbreidingstraat 54  
2600 ANTWERPEN  
Tel: +32 3 2307106  
Fax: +32 3 2301153  
Internet: www.mampaey.be  
E-mail: info@mampaey.be
- B Thema S.A.**  
6, Avenue de l'expansion  
4460 GRACE-HOLLOGNE  
Tel: +32 4 2469575  
Fax: +32 4 2469576  
Internet: www.thema-sa.be  
E-mail: info@thema-sa.be
- E Termibarna S.A.**  
C. Zamora 55-59  
08005 BARCELONA  
Tel: +34 3 3000204  
Fax: +34 3 3009558
- E D.A.C. S.A.**  
Tomás A. Edison 29  
Poligono Cogullada  
50014 ZARAGOZA  
Tel: +34 76 464076  
Fax: +34 76 471311  
Internet: www.dac.es  
E-mail: dac@dac.es
- E Cuatrocesa S.A.**  
c) Sor Angela de La Cruz, 10  
- 1º Oficina C  
28020 MADRID  
Tel: +34 91 658 18 88  
Fax: +34 91 658 30 77
- E Norte Comercial Organización S.A.**  
Bereteage Bidea, 19  
48180 LOIU (Vizcaya)  
Tel: +34 94 471 03 33  
Fax: +34 94 471 11 52  
E-mail: nco@nco.es
- GB Broag Ltd.**  
Remeha House  
Molly Millars Lane  
RG41 2QP WOKINGHAM, Berks.  
Tel: +44 118 9783434  
Fax: +44 118 9786977  
Internet: uk.remeha.com  
E-mail: boilers@broag-remeha.com
- H Marketbau - Remeha Kft.**  
Gyár u. 2.  
Ipari Park  
2040 BUDAÖRS  
Tel: +36 23 503 980  
Fax: +36 23 503 981  
Internet: www.remeha.hu  
E-mail: remeha@remeha.hu
- IRL Euro Gas Ltd.**  
Unit 38, Southern Cross Business Park  
Boghall Road, Bray, Co  
WICKLOW  
Tel: +353 12868244  
Fax: +353 12861729  
Internet: www.eurogas.ie  
E-mail: sales@eurogas.ie
- IT Revis S.r.l**  
Via Trieste 4a  
31025 Santa Lucia di Piave (TV)  
Tel: +39 0438 701907  
Fax: +39 02 36028583  
Internet: www.re-vis.it  
E-mail: info@re-vis.it

© Copyright

All technical and technological information contained in these technical instructions, as well as any drawings and technical descriptions supplied, remain our property and shall not be multiplied without our prior consent in writing.

Subject to alterations.

20/09/2011

