

Gas oil burner

Two stage operation

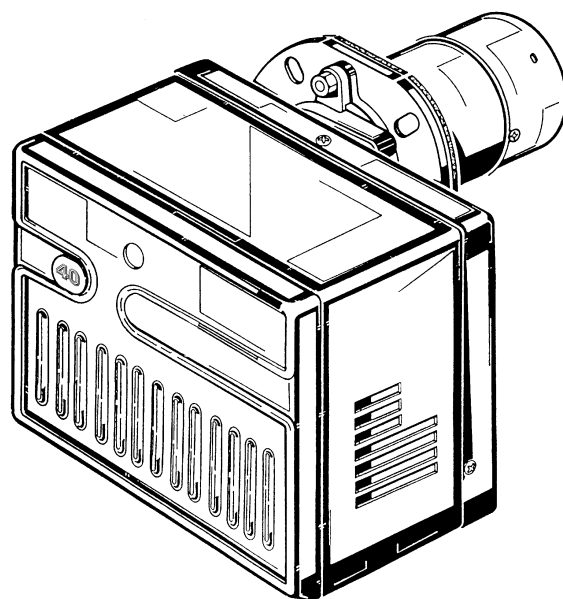

RIELLO 40 B₁₀

CODE	MODEL	TYPE
20030870	G10I	466T1



Original instructions

1	Declaration	3
2	Information and general warnings	4
2.1	Information about the instruction manual	4
2.1.1	Introduction	4
2.1.2	General dangers	4
2.1.3	Danger: live components	4
2.2	Guarantee and responsibility	5
2.3	Guidance for the use of bio fuel blends up to 30%	5
2.3.1	Information and general instructions	6
2.3.2	Product Disclaimer Statement	6
3	Safety and prevention	7
3.1	Introduction	7
3.2	Safety warnings	7
3.3	Basic safety rules	7
3.4	Personnel training	7
4	Technical description of the burner	8
4.1	Technical data	8
4.2	Burner description	8
4.3	Burner equipment	8
4.4	Burner dimensions	9
4.5	Firing rate	9
5	Installation	10
5.1	Notes on safety for the installation	10
5.2	Handling	10
5.3	Preliminary checks	10
5.4	Installer/Service notes for the use of Gas oil with Bio blends up to 30%	11
5.5	Working position	11
5.6	Securing the burner to the boiler	12
6	Hydraulic systems	13
6.1	Fuel supply	13
6.1.1	Pump	13
6.2	Two pipe system	14
6.2.1	Priming pump	14
6.3	One pipe system	15
6.3.1	Priming pump	15
7	Electrical system	16
7.1	Notes on safety for the electrical wiring	16
7.2	Electrical wiring	17
7.2.1	Control box	18
8	Start-up, calibration and operation of the burner	19
8.1	Notes on safety for the first start-up	19
8.2	Combustion adjustment	19
8.3	Nozzles installation	19
8.3.1	Nozzles recommended	19
8.4	Combustion head adjustment	20
8.5	Air damper adjustment	20
8.6	Pump pressure and air output	21
8.6.1	1st stage adjustment	21
8.6.2	2nd stage adjustment	21

8.7	Electrode setting.....	21
8.8	Economizer	22
8.9	Burner start-up cycle	22
9	Maintenance	23
9.1	Notes on safety for the maintenance.....	23
9.2	Maintenance programme	23
9.2.1	Maintenance frequency	23
9.2.2	Maintenance position	23
9.2.3	Checking and cleaning	23
10	Faults / Solutions	25

1 Declaration**Declaration of conformity in accordance with ISO / IEC 17050-1**

Manufacturer:	RIELLO S.p.A.	
Address:	Via Pilade Riello, 7 37045 Legnago (VR)	
Product:	Gas oil burner	
Model:	G10I	
These products are in compliance with the following Technical Standard:		
EN 12100		
EN 267		
and according to the European Directives:		
MD	2006/42/EC	Machine Directive
LVD	2006/95/EC	Low Voltage Directive
EMC	2004/108/EC	Electromagnetic Compatibility

The quality is guaranteed by a quality and management system certified in accordance with UNI EN ISO 9001.

Legnago, 30.07.2010

Mr. G. Conticini
Burners Division Department
RIELLO S.p.A.

Mr. R. Cattaneo



2 Information and general warnings

2.1 Information about the instruction manual

2.1.1 Introduction

The instruction manual supplied with the burner:

- is an integral and essential part of the product and must not be separated from it; it must therefore be kept carefully for any necessary consultation and must accompany the burner even if it is transferred to another owner or user, or to another system. If the manual is lost or damaged, another copy must be requested from the Technical Assistance Service of the area;
- is designed for use by qualified personnel;
- offers important indications and instructions relating to the installation safety, start-up, use and maintenance of the burner.

Symbols used in the manual

In some parts of the manual you will see triangular DANGER signs. Pay great attention to these, as they indicate a situation of potential danger.

2.1.2 General dangers

The **dangers** can be of **3 levels**, as indicated below.



Maximum danger level!
This symbol indicates operations which, if not carried out correctly, cause serious injury, death or long-term health risks.



This symbol indicates operations which, if not carried out correctly, may cause serious injury, death or long-term health risks.



This symbol indicates operations which, if not carried out correctly, may cause damage to the machine and/or injury to people.

2.1.3 Danger: live components



This symbol indicates operations which, if not carried out correctly, lead to electric shocks with lethal consequences.

Other symbols



ENVIRONMENTAL PROTECTION

This symbol gives indications for the use of the machine with respect for the environment.

- This symbol indicates a list.

Abbreviations used

Ch.	Chapter
Fig.	Figure
Page	Page
Sec.	Section
Tab.	Table

Delivery of the system and the instruction manual

When the system is delivered, it is important that:

- the instruction manual is delivered to the user by the system manufacturer, with the recommendation to keep it in the room where the heat generator is to be installed.
- The instruction manual shows:
 - the serial number of the burner;

.....

- the address and telephone number of the nearest Assistance Centre.

.....

- The system supplier must carefully inform the user about:
 - the use of the system;
 - any further tests that may be required before activating the system;
 - maintenance, and the need to have the system checked at least once a year by a representative of the manufacturer or another specialised technician.
To ensure a periodic check, the manufacturer recommends the drawing up of a Maintenance Contract.

2.2 Guarantee and responsibility

The manufacturer guarantees its new products from the installation date, in accordance with the regulations in force and/or the sales contract. At the moment of the first start-up, check that the burner is integral and complete.



WARNING

Failure to observe the information given in this manual, operating negligence, incorrect installation and carrying out of non authorised modifications will result in the annulment by the manufacturer of the guarantee that it supplies with the burner.

In particular, the rights to the guarantee and the responsibility will no longer be valid, in the event of damage to things or injury to people, if such damage/injury was due to any of the following causes:

- incorrect installation, start-up, use and maintenance of the burner;
- improper, incorrect or unreasonable use of the burner;
- intervention of unqualified personnel;
- carrying out of unauthorised modifications on the equipment;
- use of the burner with safety devices that are faulty, incorrectly applied and/or not working;
- installation of untested supplementary components on the burner;
- powering of the burner with unsuitable fuels;
- faults in the fuel supply system;
- continuation of use of the burner when a fault has occurred;
- repairs and/or overhauls incorrectly carried out;
- modification of the combustion chamber with inserts that prevent the regular development of the structurally established flame;
- insufficient and inappropriate surveillance and care of those burner components most likely to be subject to wear and tear;
- the use of non-original components, including spare parts, kits, accessories and optional;
- force majeure.

The manufacturer furthermore declines any and every responsibility for the failure to observe the contents of this manual.

Riello warranty is subject to correct burner, appliance and application matching, and set up in line with Riello's instructions and guidelines. All components within the hydraulic circuit suitable for bio fuel use and supplied by Riello will be identified as Bio compatible. No warranty is given in relation to the use of components which are not so identified with bio fuel blends. If in any doubt please contact Riello for further advice.

If any Riello burners are used with fuel with a bio content >30% then the components within the hydraulic circuit maybe affected and are not covered under warranty.

The hydraulic circuit consists of:

- Pump
- Hydraulic ram (where applicable)
- Valve block
- Flexible oil lines (considered as a consumable component)

- 1 Irrespective of any warranty given by Riello in relation to normal use and manufacturing defects, when fuels not meeting the relevant standards are used, or where fuel storage issues have not been addressed correctly, or the equipment used is not compatible, if failures occur which are directly or indirectly attributed to such issues and/or to the non-observance of this guidance, then no warranty or liability is implied or accepted by Riello.
- 2 Riello have carefully chosen the specification of the bio compatible components including the flexible oil lines to protect the pump, safety valve and nozzle. The Riello warranty is dependent upon the use of Riello genuine components including the oil lines, being used.
- 3 Riello warranty does not cover defects arising from incorrect commissioning or servicing by non Riello employed service engineers, and any issues impacting the burner arising from external site related issues.

2.3 Guidance for the use of bio fuel blends up to 30%

Background

With increasing focus on renewable and sustainable energy requirements, Bio fuel usage is set to increase. Riello is committed to promoting energy conservation and the use of renewable energy from sustainable resources including liquid bio fuels, however there are some technical aspects that must be considered at the planning stage of using such fuels to reduce the potential for equipment failure or the risks of fuel leakage.

Liquid Bio fuel is a generic description used for oil that can come from numerous feed stocks including recycled cooking oils. These types of oils have to be considered and treated differently from standard mineral or fossil fuels, as they are generally more acidic, hygroscopic and less stable.

Due to this, a holistic approach is needed from the specification of the liquid Bio fuel, the storage of the fuel, its oil supply line and ancillary equipment, and very importantly the oil filtration and the burner itself. The specification for FAME (Fatty Acids Methyl Ester) liquid Bio fuel is critical to reliable equipment operation.

It is a minimum requirement that the fuel blend (up to 30% Bio) is obtained with gas oil in accordance with the relevant EN standards, regional regulations and FAME in accordance with EN 14214. It is also important that the fuel blends meet the require-

ments related to operational environment conditions within the relevant EN standards.

When choosing your Riello oil products where you know Bio fuels will be in use, please make sure that a Bio compatible burner and/or components have been supplied. If an existing burner is to be used with a liquid Bio fuel then a kit may be required to make it compatible and the guidance notes enclosed concerning oil storage and filtration must be adhered to. The end user is responsible for the thorough verification of the potential risks associated with the introduction of a bio fuel blend and the suitability of the appliances and installation applicable.

Irrespective of any warranty given by Riello in relation to normal use and manufacturing defects, when fuels not meeting the relevant standards are used, or where fuel storage issues have not been addressed correctly, or the equipment used is not compatible, if failures occur which are directly or indirectly attributed to such issues and/or to the non-observance of this guidance, then no warranty or liability is implied or accepted by Riello.

2.3.1 Information and general instructions

To ensure consistency, the supplier of the fuel must be able to demonstrate compliance with a recognised Quality Control and management system to ensure high standards are maintained within the storage, blending and delivery processes.

The installation oil storage tank and its ancillaries must also be prepared BEFORE liquid Bio fuel is introduced.

Checks and preparation should include:

- For new installations, make sure that all materials and seals in the oil storage and supply line to the burner are compatible with Bio fuels. For all installations, there must be a good quality bio compatible oil filter at the tank and then a secondary filter of 60 Microns protecting the burner from contamination.
- If an existing oil storage tank is to be used then in addition to the materials checks as detailed above, it will be essential that the tank is first inspected for condition and checked for water or other contamination. Riello strongly recommends that the tank is cleaned and oil filters replaced prior to Bio fuel delivery. If this is not completed then due to the hydroscopic nature of Bio fuel, it will effectively clean the tank, absorb water present which in turn will result in equipment failure that is not covered by the manufacturer's warranty.
- Depending on the capacity of the oil storage tank and oil usage, fuels may remain static within the tank for some considerable time and so Riello recommends that the oil distributor is consulted regarding the use of additional Biocides within the fuel to prevent microbial growth from occurring within the tank. Riello suggests that fuel suppliers and or service companies are contacted for guidance on fuel filtration. Special attention should be applied to fuel applications where oil may be stored for long periods of time.
- The burner must be set according to the appliance application and commissioned checking that all combustion parameters are as recommended in the appliance technical manual.
- Riello recommends that the in line and burner oil pump filters are inspected and if required replaced at least every 4 months during burner use, before the burner start-up following a long period of discontinue operation and even more frequently where contamination has occurred. Particular attention is needed when inspecting and checking for fuel leakages from seals, gaskets and hoses.

2.3.2 Product Disclaimer Statement

CAREFULLY READ THE FOLLOWING DISCLAIMER. YOU ACCEPT AND AGREE TO BE BOUND BY THIS DISCLAIMER BY PURCHASING RIELLO BIO COMPATIBLE BURNERS AND/OR COMPONENTS.

Although the information and recommendations (hereinafter "Information") in this guidance is presented in good faith, believed to be correct and has been carefully checked, Riello (and its subsidiaries) makes no representations or warranties as to the completeness or accuracy of the Information. Information is supplied upon the condition that the persons receiving same will make their own determination as to its suitability for their purposes prior to use. In no event will Riello (and its subsidiaries) be responsible for damages of any nature whatsoever resulting from the use of or reliance upon Information.

Other than set forth herein, Riello (and its subsidiaries) makes no additional warranties with respect to the bio compatible burner, either express or implied, including that of merchantability or fitness for a particular purpose or use.

In no event shall Riello (and its subsidiaries) be liable for any indirect, incidental, special or consequential damages including, without limitation, loss of profits, damages for loss of business profits, business interruption, loss of business information, loss of equipment, or other pecuniary loss or compensation for services whether or not it is advised of the possibility of such damages.

With the exception of injuries to persons, Riello's liability is limited to the customer's right to return defective/non-conforming products as provided by the relevant product warranty.

3 Safety and prevention

3.1 Introduction

The burners have been designed and built in compliance with current regulations and directives, applying the known technical rules of safety and envisaging all the potential danger situations.

It is necessary, however, to bear in mind that the imprudent and clumsy use of the equipment may lead to situations of death risk for the user or third parties, as well as the damaging of the burner or other items. Inattention, thoughtlessness and excessive confidence often cause accidents; the same applies to tiredness and sleepiness.

It is a good idea to remember the following:

- The burner must only be used as expressly described. Any other use should be considered improper and therefore dangerous.

In particular:

it can be applied to boilers operating with water, steam, diathermic oil, and to other uses expressly named by the manufacturer;

the type and pressure of the fuel, the voltage and frequency of the electrical power supply, the minimum and maximum deliveries for which the burner has been regulated, the pressurisation of the combustion chamber, the dimensions of the combustion chamber and the room temperature must all be within the values indicated in the instruction manual.

- Modification of the burner to alter its performance and destinations is not allowed.
- The burner must be used in exemplary technical safety conditions. Any disturbances that could compromise safety must be quickly eliminated.
- Opening or tampering with the burner components is not allowed, apart from the parts requiring maintenance.
- only those parts detailed as available as spare parts by the manufacturer can be replaced.

3.2 Safety warnings

The dimension of the boiler's combustion chamber must respond to specific values, in order to guarantee a combustion with the lowest polluting emissions rate.

The Technical Service Personnel will be glad to give you all the information for a correct matching of this burner to the boiler.

This burner must only be used for the application it was designed for.

The manufacturer accepts no liability within or without the contract for any damage caused to people, animals and property due to installation, adjustment and maintenance errors or to improper use.

3.3 Basic safety rules

- Children or inexperienced persons must not use the appliance.
- Under no circumstances must the intake grids, dissipation grids and ventilation vents in the installation room be covered up with cloths, paper or any other material.
- Unauthorised persons must not attempt to repair the appliance.
- It is dangerous to pull or twist the electric leads.
- Cleaning operations must not be performed if the appliance is not disconnected from the main power supply.
- Do not clean the burner or its parts with inflammable substances (e.g. petrol, alcohol, etc.). The cover must be cleaned with soapy water.
- Do not place anything on the burner.
- Do not block or reduce the size of the ventilation vents in the installation room.
- Do not leave containers and inflammable products or combustible materials in the installation room.

3.4 Personnel training

The user is the person, body or company that has acquired the machine and intends to use it for the specific purpose. He is responsible for the machine and for the training of the people working around it.

The user:

- undertakes to entrust the machine exclusively to suitably trained and qualified personnel;
- must take all the measures necessary to prevent unauthorised people gaining access to the machine;
- undertakes to inform his personnel in a suitable way about the application and observance of the safety instructions. With that aim, he undertakes to ensure that everyone knows the use and safety instructions for his own duties;
- must inform the manufacturer if faults or malfunctioning of the accident prevention systems are noticed, along with any presumed danger situation.
- Personnel must always use the personal protective equipment envisaged by legislation and follow the indications given in this manual.
- Personnel must observe all the danger and caution indications shown on the machine.
- Personnel must not carry out, on their own initiative, operations or interventions that are not within their province.
- Personnel must inform their superiors of every problem or dangerous situation that may arise.
- The assembly of parts of other makes, or any modifications, can alter the characteristics of the machine and hence compromise operating safety. The manufacturer therefore declines any and every responsibility for any damage that may be caused by the use of non-original parts.

4 Technical description of the burner

4.1 Technical data

Type	466T1
Thermal power – output	44/54 – 120 kW – 3.7/4.5 – 10 kg/h
Fuel	Gas oil, viscosity 4 – 6 mm ² /s at 20 °C (Hi = 11.86 kWh/kg) Kerosene, viscosity 1.6 – 6 mm ² /s at 20 °C (Hi = 11.97 kWh/kg) Blends of gasoil and bio fuel (FAME in accordance with EN 14214) up to 30%
Electrical supply	Single phase, ~ 50Hz 230 V ± 30%
Motor	Run current 0.8A – 90W – 2800 rpm – 294 rad/s
Capacitor	4 µF
Ignition transformer	Secondary 8 kV – 16 mA
Pump	Pressure 7 – 14 bar
Absorbed electrical power	0.17 kW

Tab. A

4.2 Burner description

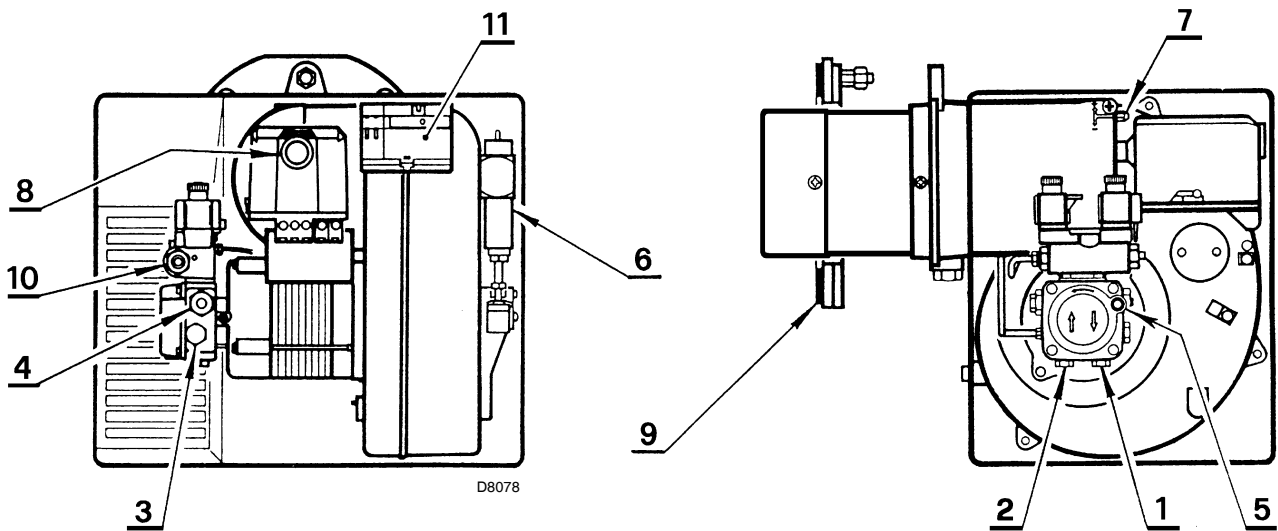

Fig. 1

- | | |
|---|---|
| 1 Return line | 7 Combustion head adjustment screw |
| 2 Suction line | 8 Lock-out lamp and reset button |
| 3 Gauge connection | 9 Flange with insulating gasket |
| 4 Pressure regulator, 2 nd stage | 10 Regulation pressure, 1 st stage |
| 5 Vacuum gauge connection | 11 Economizer |
| 6 Hydraulic jacks with air-damper | |

4.3 Burner equipment

- | | |
|--------------------------------------|-------|
| Hoses with nipples | No. 2 |
| Flange with insulating gasket | No. 1 |
| Screws and nuts for flange | No. 4 |
| Screw with two nuts for flange | No. 1 |
| Maintenance assembly | No. 1 |
| External probe | No. 1 |
| 7 pin plug | No. 1 |
| 4 pin plug | No. 1 |



In case of use with gas oil containing up to 30% Bio blend, it will be essential to use flexible oil lines suitable for bio fuel use. Please contact Riello for further information.

4.4 Burner dimensions

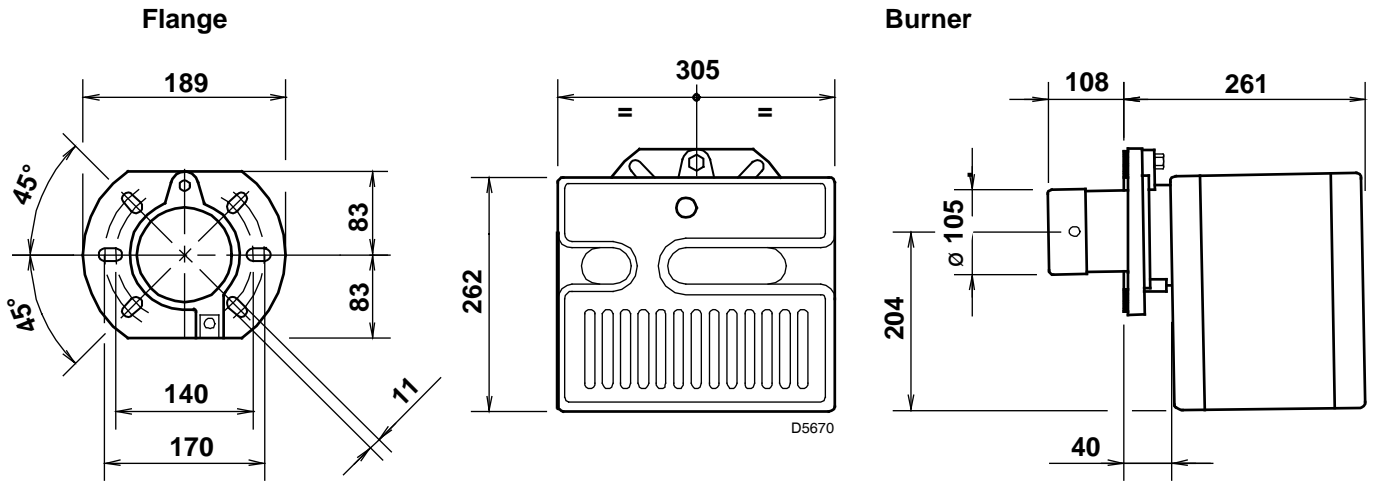

Fig. 2

4.5 Firing rate

The **MAXIMUM OUTPUT** is chosen from within the diagram area (Fig. 3).

The **MINIMUM OUTPUT** must not be lower than the minimum limit of the diagram.

The burner delivery must be selected within area of the diagrams (Fig. 3). This area is called firing rate and provides the maximum delivery of the burner in relation to the pressure in the combustion chamber.

The work point may be found by plotting a vertical line from the desired delivery and a horizontal line from the pressure in the combustion chamber. The intersection of these two lines is the work point which must lie within the firing rates.



The firing rate area values have been obtained considering a surrounding temperature of 20 °C, and an atmospheric pressure of 1013 mbar (approx. 0 m above sea level).

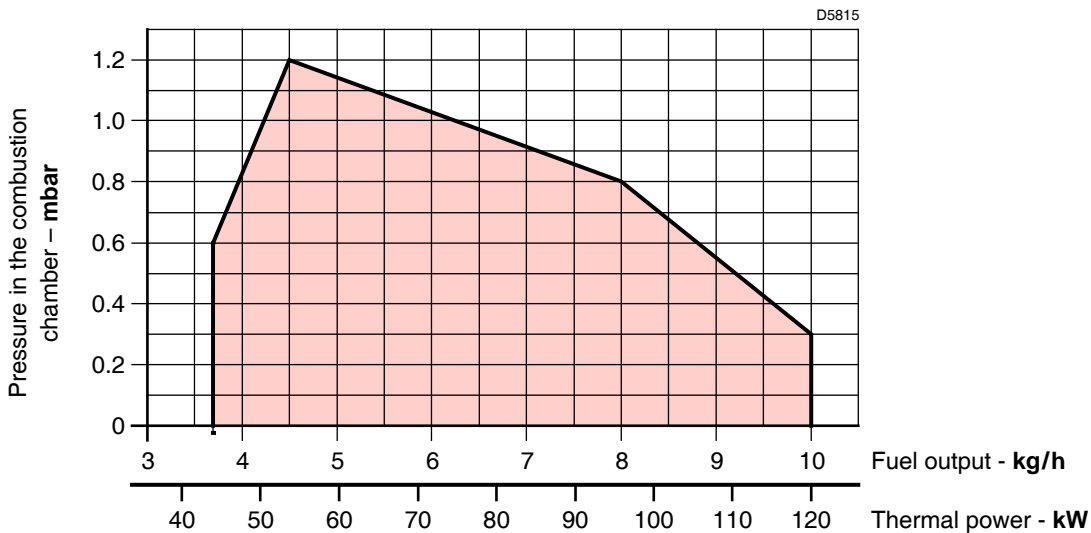

Fig. 3

5 Installation

5.1 Notes on safety for the installation

After carefully cleaning all around the area where the burner will be installed, and arranging the correct lighting of the environment, proceed with the installation operations.



All the installation, maintenance and disassembly operations must be carried out with the electricity supply disconnected.



The installation of the burner must be carried out by qualified personnel, as indicated in this manual and in compliance with the standards and regulations of the laws in force.

5.2 Handling

The packaging of the burner includes a carton box, so it is possible to move the burner (still packaged) with a transpallet truck or fork lift truck.



The handling operations for the burner can be highly dangerous if not carried out with the greatest attention: keep any unauthorised people at a distance; check the integrity and suitability of the available means of handling. Check also that the area in which you are working is empty and that there is an adequate escape area (i.e. a free, safe area to which you can quickly move if the burner should fall). When handling, keep the load at not more than 20-25 cm from the ground.



After positioning the burner near the installation point, correctly dispose of all residual packaging, separating the various types of material. Before proceeding with the installation operations, carefully clean all around the area where the burner will be installed.

5.3 Preliminary checks

Checking the consignment



After removing all the packaging, check the integrity of the contents. In the event of doubt, do not use the burner; contact the supplier.



The output of the burner must be within the boiler's firing rate;



The packaging elements (wooden cage or cardboard box, nails, clips, plastic bags, etc.) must not be abandoned as they are potential sources of danger and pollution; they should be collected and disposed of in the appropriate places.



A burner label that has been tampered with, removed or is missing, along with anything else that prevents the definite identification of the burner makes any installation or maintenance work difficult.

Checking the characteristics of the burner

R.B.L.	A		B		
	D	C	G		
	B	E			
	F				
RIELLO S.p.A. I-37045 Legnago (VR)					XXXX

Fig. 4

- Check the identification label of the burner, showing:
- the model **A**(Fig. 4) and type of burner **B**);
 - the year of manufacture, in cryptographic form **C**);
 - the serial number **D**);
 - the electrical input power **E**);
 - the types of fuel used and the relative supply pressures **F**);
 - the data of the burner's minimum and maximum output possibilities **G**)(see Firing rate)

5.4 Installer/Service notes for the use of Gas oil with Bio blends up to 30%

- During the burner installation, check that the gas oil and bio fuel blends are in accordance with Riello specifications (please refer to the chapters "Technical Data" and "Guidance for the use of bio fuel blends up to 30%" within the burner technical manual).
- If a Bio blend is in use the installer must seek information from the end user that their fuel supplier can evidence that the blends of fuel conform to the relevant standards.
- Check that the materials used in the construction of the oil tank and ancillary equipment are suitable for bio fuels, If not these must be upgraded or replaced with Bio compatible parts.
- Particular attention should be given to the oil storage tank and supply to the burner. Riello recommends that existing oil storage tanks are cleaned, inspected and any traces of water are removed BEFORE bio fuel is introduced (Contact the tank manufacturer or oil supplier for further advice). If these recommendations are not respected this will increase the risk of contamination and possible equipment failure.
- In line oil filters should be replaced making sure that they are Bio compatible. Riello recommends a good quality bio compatible oil filter at the tank and a secondary 60 micron filter are used to protect the burner pump and nozzle from contamination.
- The burner hydraulic components and flexible oil lines must be suitable for bio fuel use (check with Riello if in doubt). Riello have carefully chosen the specification of the bio compatible components including the flexible oil lines to protect the pump, safety valve and nozzle. The Riello warranty is dependent upon the use of Riello genuine components including the oil lines, being used. The burner must be commissioned and combustion parameters set to appliance manufacturer's recommendations.
- Regularly check visually for any signs of oil leakage from seals, gaskets and hoses.
- It is strongly recommended that with Bio fuel use, oil filters are inspected and replaced every 4 months. More regularly where contamination is experienced.
- During extended periods of non operation and/or where burners are using oil as a standby fuel, it is strongly recommended that the burner is put into operation for shorts periods at least every three months.

5.5 Working position



WARNING

The burner is designed to operate only in the positions 1, 2, 3 and 4 (Fig. 5).

Installation 1 is preferable, as it is the only one that allows performing maintenance operations as described in this manual.

Installation 4 allows working operations but not maintenance with hooking to the boiler.



DANGER

Any other position could compromise the correct operation of the appliance.

Installation 5 is forbidden for safety reasons.

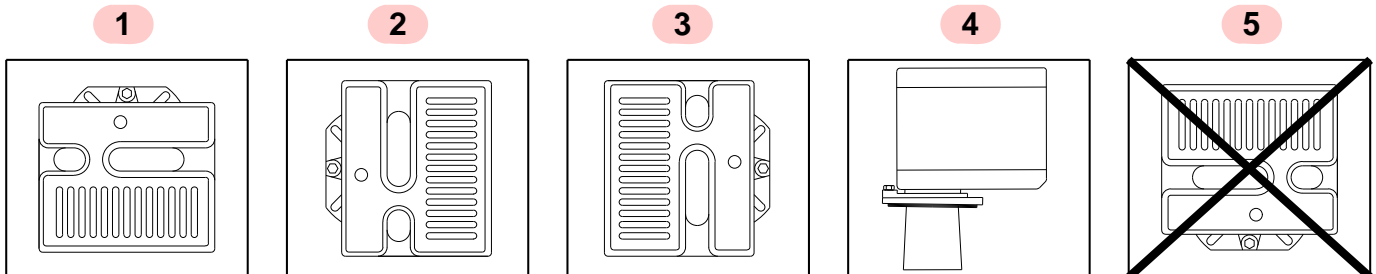

D10931

Fig. 5

5.6 Securing the burner to the boiler

- Put on the flange 1)(Fig. 6) the screw 2) and two nuts 3).
- It is necessary that the insulating gasket 5)(Fig. 9) is placed between the boiler door and the burner flange.
If necessary, the insulating gasket can be modified as shown in Fig. 7.
- Fix the flange 1) to the boiler door 4) using screws 2) and (if necessary) the nuts 3) interposing the insulating gasket 5).
- Verify that the installed burner is lightly leaned towards the button (Fig. 8).

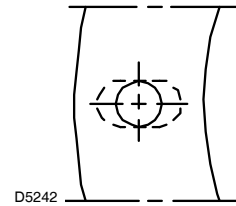

Fig. 7

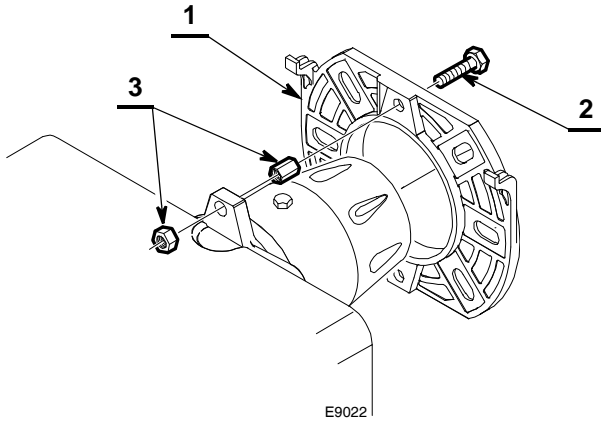

Fig. 6

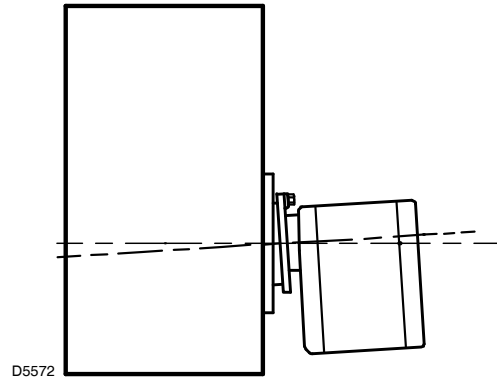

Fig. 8

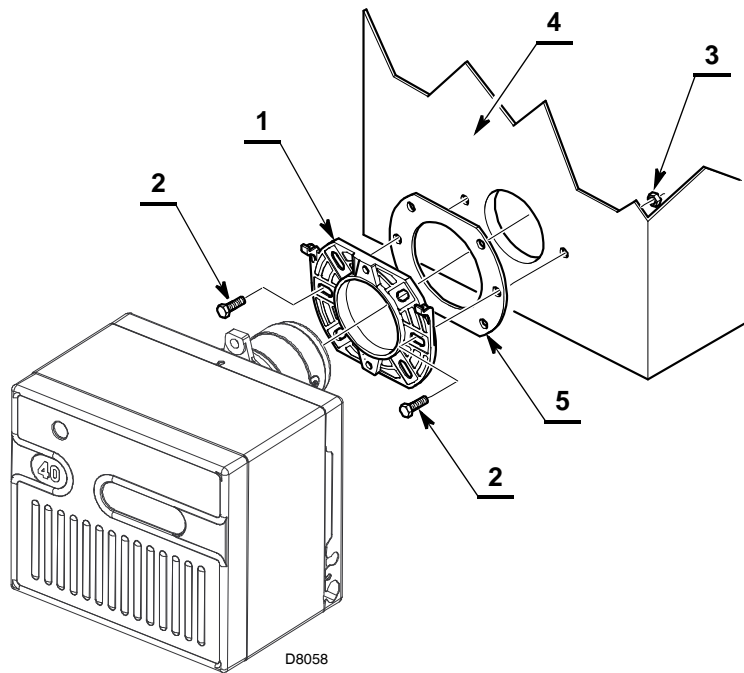

Fig. 9

6 Hydraulic systems

6.1 Fuel supply

- The burner is designed to allow entry of the hoses-lines on either side of the burner.

6.1.1 Pump

The pump is designed to allow working with two pipes.

In order to obtain one pipe working it is necessary to unscrew the return hose, remove the by-pass screw 3) and then screw the return plug 2).

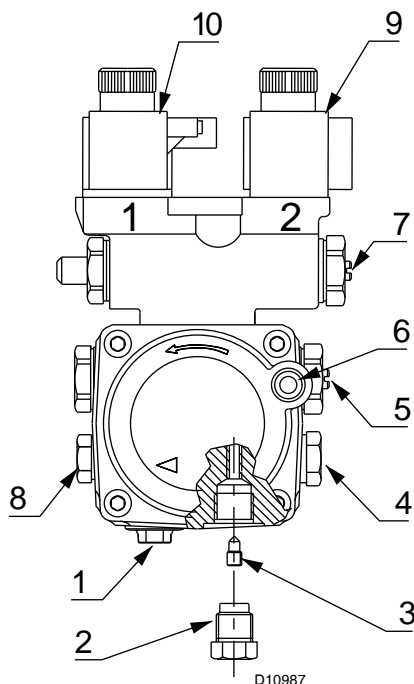

Fig. 10

Key (Fig. 10)

1	Suction line	6	Suction gauge connection
2	Return line	7	1 st stage pressure adjuster
3	By-pass screw	8	Auxiliary pressure test point
4	Gauge connection	9	2 nd stage valve
5	2 nd stage pressure adjuster	10	1 st stage valve



WARNING

Where gas oil containing bio diesel is in use, it is recommended to avoid over oxygenation of the blended fuels.

Where at all possible avoid the use of two pipe systems where the circulated fuel is returned to the tank.

If this cannot be avoided make sure that the return pipe is normally below the surface of the fuel level within the storage tank. See Fig. 11.



WARNING

The suction plug 1) is made of plastic. Once removed, it must not be used again.

In single pipe installations, the plug in the return line 2) must be totally in steel.



WARNING

In case of use with gas oil containing up to 30% Bio blend, it will be essential to use flexible oil lines suitable for bio fuel use.

Please contact Riello for further information.



DANGER

It is strongly recommended a periodic check of the pump pressure operation (annually or better every six months, if the burner operation is continuous).

If the value is lower than 1 bar, compared to that one of the initial setting, please check the cleaning of the pump and line filters.

In case the pressure setting was not restorable, please replace the pump, in order to guarantee that the pump pressure during the pre-purge time is at least 3.7 bar.

6.2 Two pipe system

Vacuum two pipe systems (Fig. 11) have a negative fuel pressure (depression) on intake to the burner. Usually the tank is lower than the burner.

The return line should terminate in the oil tank at the same level as the suction line; in this case a non-return valve is not required.

Should however the return line arrives over the fuel level, the non-return valve is indispensable. This solution however is less safe than previous one, due to the possibility of leakage of the valve.



You are advised to use additional filters on the fuel supply line.

Riello recommends a good quality fuel filter at the tank (Fig. 11) and a secondary filter (60 μ for gas oil and 15 μ for kerosene) are used to protect the burner pump and nozzle from contamination.

In case of Biodiesel use, pay attention to install Biocompatible filters.

6.2.1 Priming pump



Before starting the burner make sure that the return pipe-line is not clogged: any obstruction would cause the pump seals to break.

On the system in Fig. 11 start the burner and wait for the priming. Should lock-out occur prior to the arrival of the fuel, await at least 20 seconds before repeating the operation.



The pump vacuum should not exceed a maximum of 0.4 bar (30 cm Hg). Beyond this limit gas is released from the oil.

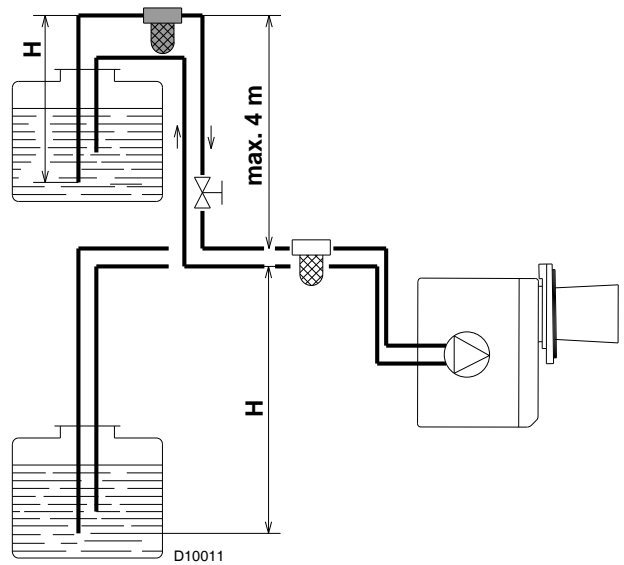

Fig. 11

H metres	L metres	
	I.D. (8 mm)	I.D. (10 mm)
0	35	100
0.5	30	100
1	25	100
1.5	20	90
2	15	70
3	8	30
3.5	6	20

Tab. B

- H** difference of level
- L** max. length of the suction line
- I.D.** interterminal diameter of the oil pipes

NOTE:

The Tab. B shows the maximum approximate lengths for the supply line, depending on the difference in level, length, and the diameter of the fuel conduit.

6.3 One pipe system

Pressurised one pipe systems (Fig. 12) have a positive fuel pressure on intake to the burner.

Usually the tank is higher than the burner, or the fuel pumping systems are on the outside of the boiler.

Vacuum one pipe systems (Fig. 13) have a negative fuel pressure (depression) on intake to the burner.

Usually the tank is lower than the burner.



You are advised to use additional filters on the fuel supply line.

Riello recommends a good quality fuel filter at the tank (Fig. 12 - Fig. 13) and a secondary filter (60 μ for gas oil and 15 μ for kerosene) are used to protect the burner pump and nozzle from contamination.

In case of Biodiesel use, pay attention to install Biocompatible filters.

6.3.1 Priming pump

On the system in Fig. 12 it is sufficient to loosen the plug of the vacuum gauge 6)(Fig. 10) and wait until the fuel flows out.

On the system in Fig. 13 start the burner and wait for the priming. Should lock-out occur prior to the arrival of the fuel, await at least 20 seconds before repeating the operation.



The installer must ensure that the supply pressure is not above 0.5 bar.

Above that level, the pump seal is subject to too much stress.

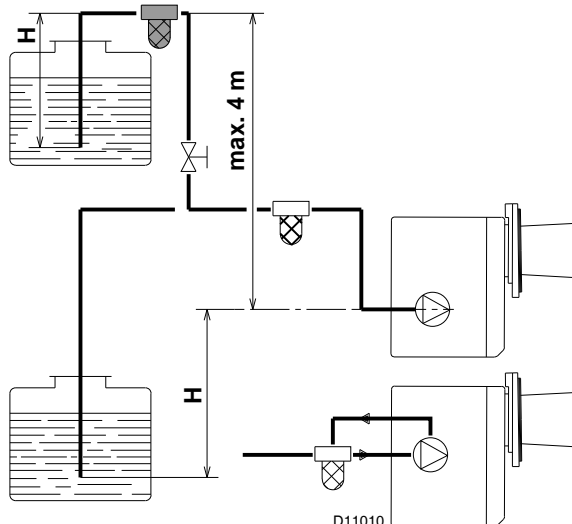

Fig. 13

H metres	L metres	
	I.D. (8 mm)	I.D. (10 mm)
0	35	100
0.5	30	100
1	25	100
1.5	20	90
2	15	70
3	8	30
3.5	6	20

Tab. D

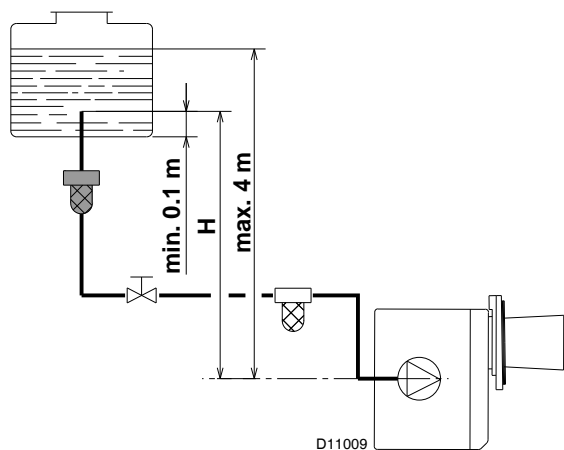

Fig. 12

H metres	L metres	
	I.D. (8 mm)	I.D. (10 mm)
0.5	10	20
1	20	40
1.5	40	80
2	60	100

Tab. C

H difference of level
 L max. length of the suction line
 I.D. interterminal diameter of the oil pipes

NOTE:

The Tab. C and Tab. D show the maximum approximate lengths for the supply line, depending on the difference in level, length, and the diameter of the fuel conduit.

7 Electrical system**7.1 Notes on safety for the electrical wiring****DANGER**

- The electrical wiring must be carried out with the electrical supply disconnected.
- Electrical wiring must be carried out by qualified personnel and in compliance with the regulations currently in force in the country of destination. Refer to the wiring diagrams.
- The manufacturer declines all responsibility for modifications or connections different from those shown in the wiring diagrams.
- Do not invert the neutral with the phase in the electrical supply line. Any inversion would cause a lockout due to firing failure.
- Check that the electrical supply of the burner corresponds to that shown on the identification label and in this manual.
- The burners have been set for intermittent operation. This means they should compulsorily be stopped at least once every 24 hours to enable the control box to perform checks of its own start-up efficiency. Normally the boiler's thermostat/pressure switch ensures the stopping of the burner.
If this is not the case, it is necessary to apply in series with IN a timer switch that turns off the burner at least once every twenty-four hours. Refer to the wiring diagrams.
- The electrical safety of the device is obtained only when it is correctly connected to an efficient earthing system, made according to current standards. It is necessary to check this fundamental safety requirement. In the event of doubt, have the electrical system checked by qualified personnel.
- The electrical system must be suitable for the maximum input power of the device, as indicated on the label and in the manual, checking in particular that the section of the cables is suitable for the input power of the device.
- For the main power supply of the device from the electricity mains:
 - do not use adapters, multiple sockets or extensions;
 - use an omnipolar switch, as indicated by the current safety standards.
- Do not touch the device with wet or damp body parts and/or in bare feet.
- Do not pull the electric cables.

Before carrying out any maintenance, cleaning or checking operations:

**DANGER**

disconnect the electrical supply from the burner by means of the main system switch;

**DANGER**

isolate the fuel supply.

If the cover is still present, remove it and proceed with the electrical wiring according to the wiring diagrams.

Use flexible cables in compliance with the EN 60 335-1 standard.

7.2 Electrical wiring



- Do not swap neutral and phase over, follow the diagram shown carefully and carry out a good earth connection.
- The electrical wiring carried out by the installer must be in compliance with the rules in force in the country.
- The section of the conductors must be at least 1mm². (Unless requested otherwise by local standards and legislation).
- Connect 2nd stage thermostat or external probe between clamps T6 - T8 removing the bridge. (See page 22: economizer functions).

230V ~ 50Hz

TESTING

Check the shut-down of the burner by opening the thermostats.

TO BE COMPLETED BY THE INSTALLER

CARRIED-OUT IN THE FACTORY

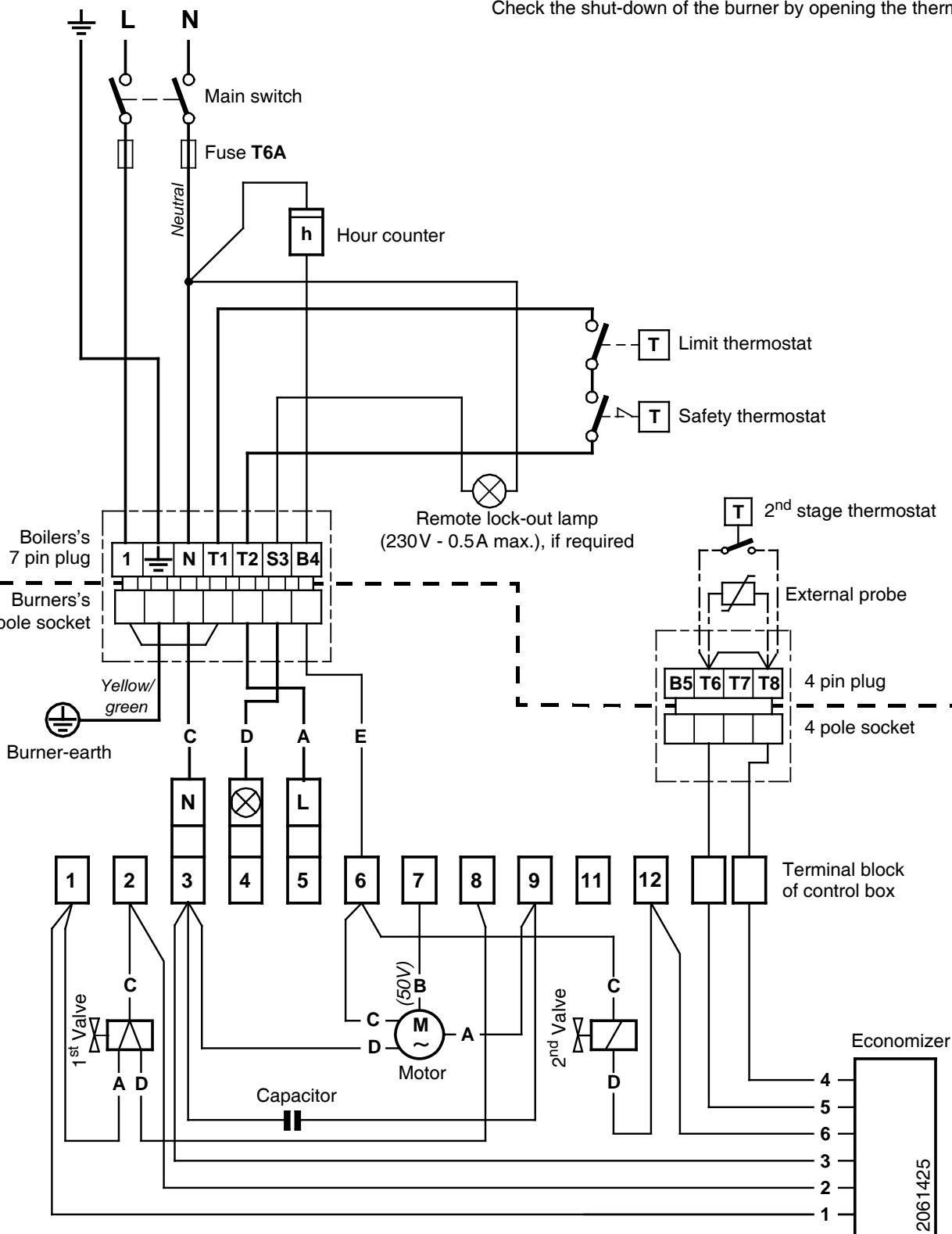

Key of the wires color

- A - Brown B - White C - Blue D - Black E - Grey

D5807

Fig. 14

7.2.1 Control box



This operation must be performed with the burner turned off and mains power disconnected.

To remove the control-box from the burner, loosen screw A)(Fig. 15) and pull towards the arrow.

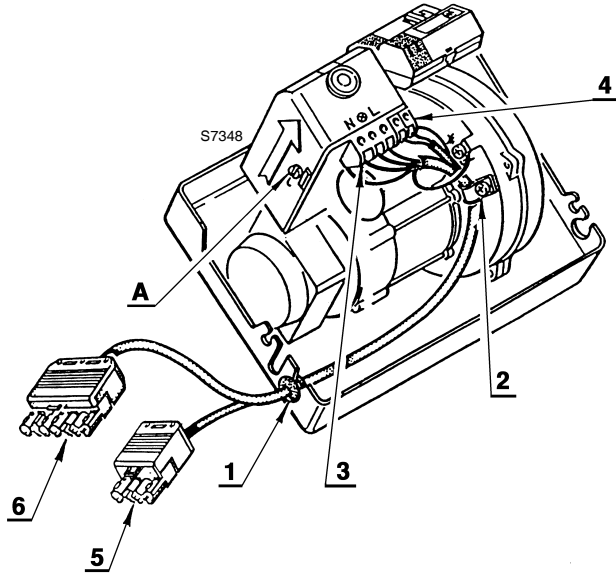

Fig. 15

Run of the electrical cable (Fig. 15)

- 1 Grommet
- 2 Cable clamp
- 3 Terminal block
- 4 Clamps for external probe or 2nd stage thermostat
- 5 4 pole socket for external probe or 2nd stage thermostat
- 6 7 pole socket for burner
- N Neutral
- L Phase
- ⊕ Burner-earth
- ⊗ Lock-out lamp

The photoresistance is fitted directly into the control box (underneath the ignition-transformer) on a plug-in support.

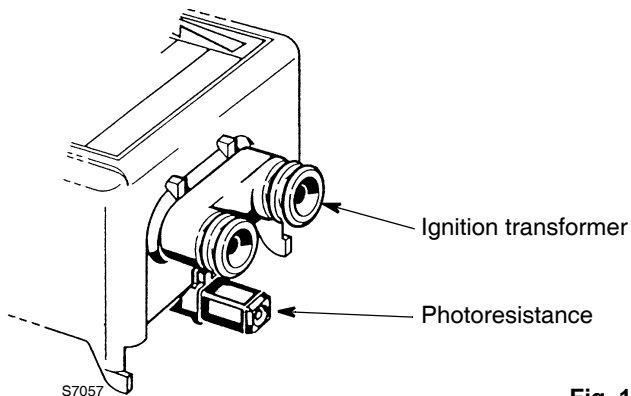

Fig. 16

8 Start-up, calibration and operation of the burner

8.1 Notes on safety for the first start-up



The first start-up of the burner must be carried out by qualified personnel, as indicated in this manual and in compliance with the standards and regulations of the laws in force.



Check the correct working of the adjustment, command and safety devices.

8.2 Combustion adjustment

In conformity with Efficiency Directive 92/42/EEC the application of the burner on the boiler, adjustment and testing must be carried out observing the instruction manual of the boiler, including verification of the CO and CO₂ concentration in the flue gases, their temperatures and the average temperature of the water in the boiler.

To suit the required appliance output, fit the nozzle then adjust the pump pressure, the setting of the combustion head and the air damper opening in accordance with the following Tab. E.

Nozzle		Pump pressure		Burner output kg/h ± 4%		Combustion head adjustment	Air damper adjustment	
GPH	Angle	bar 1 st stage	bar 2 nd stage	1 st stage	2 nd stage	Set-point	Set-point 1 st stage	Set-point 2 nd stage
1.00	60°	9	14	3.5	4.3	1.5	2.2	2.6
1.10	60°	9	14	3.8	4.8	1.5	2.4	2.9
1.25	60°	9	14	4.3	5.4	2.0	2.6	3.2
1.50	60°	9	14	5.2	6.5	2.5	2.8	3.5
1.75	60°	9	14	6.1	7.6	3.5	3.0	4.3
2.00	60°	9	14	7.0	8.7	4.0	3.3	5.0
2.25	60°	9	13	7.8	9.8	5.0	3.6	6.0

Tab. E

8.3 Nozzles installation

The burner complies with the emission requirements of the EN 267 standard.

In order to guarantee that emissions do not vary, recommended and/or alternative nozzles specified by the manufacturer in the Instruction and warning booklet should be used.



It is advisable to replace nozzles every year during regular maintenance operations.



The use of nozzles other than those specified by the manufacturer and inadequate regular maintenance may result into emission limits non-conforming to the values set forth by the regulations in force, and in extremely serious cases, into potential hazards to people and objects.

The manufacturing company shall not be liable for any such damage arising from nonobservance of the requirements contained in this manual.

8.3.1 Nozzles recommended

- Monarch type R
- Delavan type W - B
- Steinen type S - Q
- Danfoss type S



For 2.00 - 2.25 GPH nozzles it is advisable to use, if possible, full cones.

8.4 Combustion head adjustment

This is done when fitting the nozzle, with the blast tube removed. It depends on the output of the burner and is carried out by rotating the regulating rod, till the terminal plane of the blast tube is level with the set-point, as indicated in the Tab. E.

Exemple:

the combustion head is set for an output of 1.50 GPH at 8/14 bar, while the shutter is level with set-point 2.5, as required by the Tab. E.

Combustion head settings indicated in the Tab. E are valid for most cases.

The setting of the fan output according to the installation should normally be done only through the air damper.

Should one subsequently want to retouch also the setting of the combustion head, with the burner running, operate on the rod 1)(Fig. 18) with a 6 mm spanner 2) as follows:

TURN TO THE RIGHT: SIGN +

In order to increase the volume of air entering the combustion chamber and thus diminishing its pressure.

There is a reduction of CO₂ and the adhesion of the flame to the air diffuser disc improves.

(Setting advisable for ignitions at low temperatures).

TURN TO THE LEFT: SIGN -

In order to reduce the volume of air entering the combustion chamber and thus increasing its pressure.

The CO₂ improves and the adhesion of the flame to the diffuser tends to reduce.

(This setting is not advisable for ignitions at low temperatures).

In any case do not bring the combustion head setting more than one point away from that indicated in the Tab. E.

One set-point corresponds to 3 turns of the rod; a hole 3)(Fig. 18) at its end facilitates counting the number of turns.

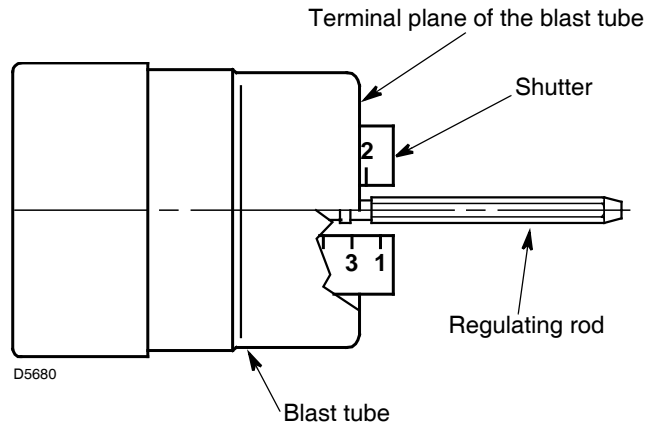

Fig. 17

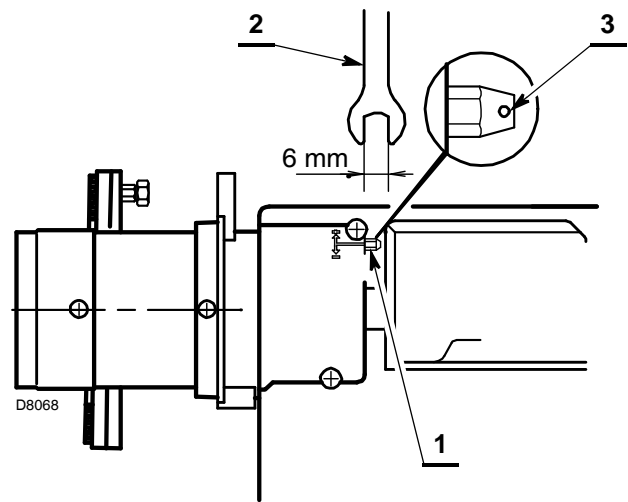

Fig. 18

8.5 Air damper adjustment

The settings indicated in the schedule refer to the burner with its metal cover fitted and the combustion chamber with "zero" depression.

These regulations are purely indicative.

Each installation however, has its own unpredictable working conditions: actual nozzle output; positive or negative pressure in the combustion-chamber, the need of excess air, etc.

All these conditions may require a different air-damper setting.

It is important to take account of the fact that the air output of the fan differs according to whether the burner has its metal cover fitted or not.

Therefore we recommended to proceed as follows:

- adjust the air damper as indicated in the Tab. E;
- mount the cover, simply by means of the upper screw;
- check smoke number;
- should it become necessary to modify the air output, remove the cover by loosening the screw, adjust the air damper, remount the cover and finally recheck the smoke number.

When the burner works at a firing rate higher than 9 kg/h remove the panel 1)(Fig. 19) fitted inside the metal cover.

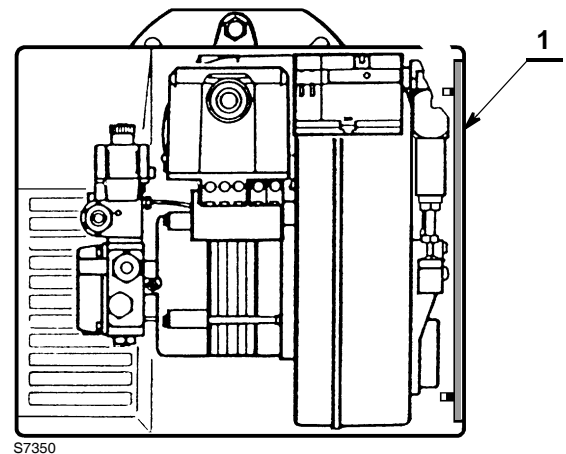

Fig. 19

8.6 Pump pressure and air output

The burner is provided with a hydraulic device controlled by the economizer which reduces to approx. 70% the max. output of gas oil and air.

8.6.1 1st stage adjustment

Adjustment of air shutter

Place the small plug 9)(Fig. 20) of the economizer 10) into the position I (Item A, Fig. 21).

In this way the burner will remain permanently in the 1st stage. Unloosen the nut 2)(Fig. 22), turn the screw 3) until the air shutter 1) reaches the position desired.

Then lock the nut 2).

Pressure regulation

This is set at 8 bar at the factory.

Should such pressure be reset or changed, just turn the screw 4)(Fig. 21).

The pressure gauge must be mounted in place of cap 5).

8.6.2 2nd stage adjustment

Adjustment of air shutter

Place the small plug 9)(Fig. 20) of the economizer 10) into the position II (Item B, Fig. 21).

In this way the burner remains permanently in the 2nd stage. Unloosen the nut 6)(Fig. 22), turn the screw 7) until the air shutter 1) reaches the position desired.

Then lock the nut 6).

Pressure regulation

This is set at 14 bar at the factory.

Should such pressure be reset or changed, just turn the screw 8)(Fig. 20).

The pressure gauge must be mounted in place of cap 5).

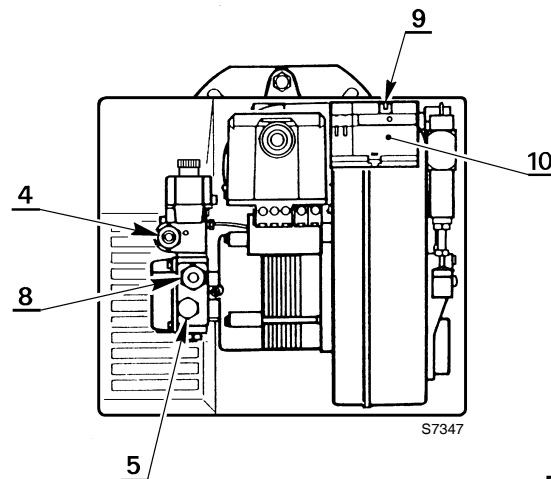

Fig. 20

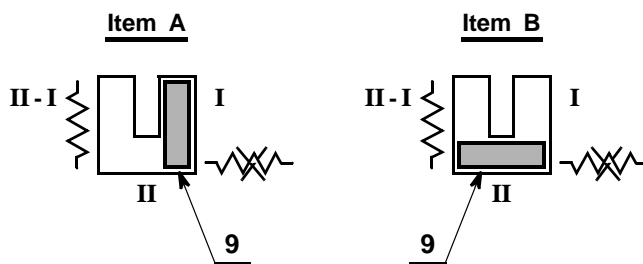

Fig. 21

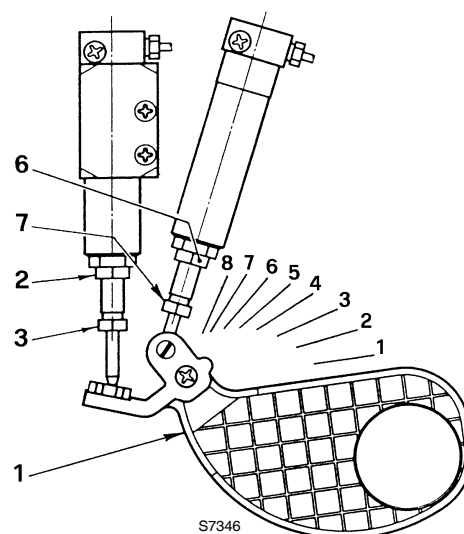

Fig. 22

8.7 Electrode setting



The position of the electrodes cannot be regulated. In case of failure, check that the measurements as shown on the figure are respected.

Before removing or assembling the nozzle, loosen the screw A)(Fig. 23) and move the electrodes ahead.

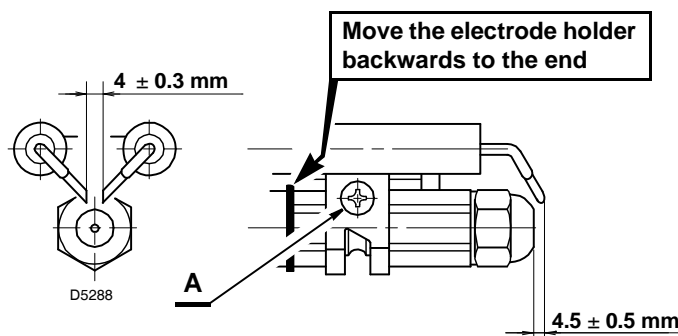

Fig. 23

8.8 Economizer

This economizer can be wired to 2nd stage thermostat or to an external probe.

The economizer, connected to the 2nd stage thermostat, performs two functions:

- 1 Delay of 5 - 6 seconds in the intervention of the 2nd stage valve against 1st stage valve.
- 2 In relation of the position of the plug **B** (Fig. 25), it determines the type of required operation:

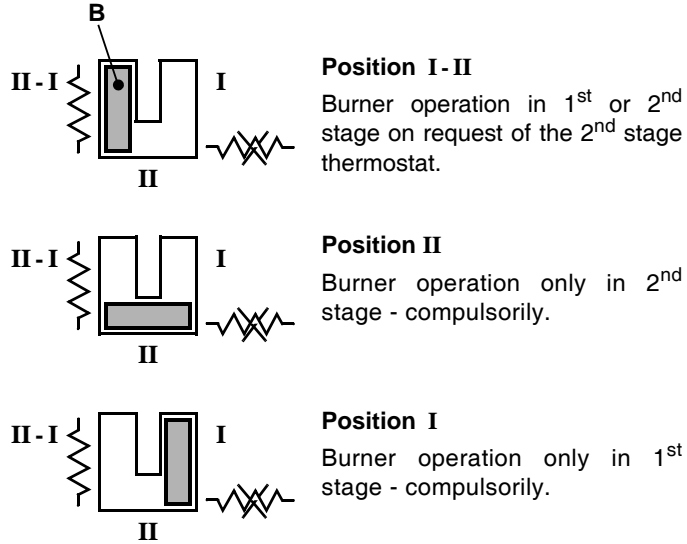

Fig. 24

NOTE

In this case the setting screw **A** (Fig. 25) is not necessary.

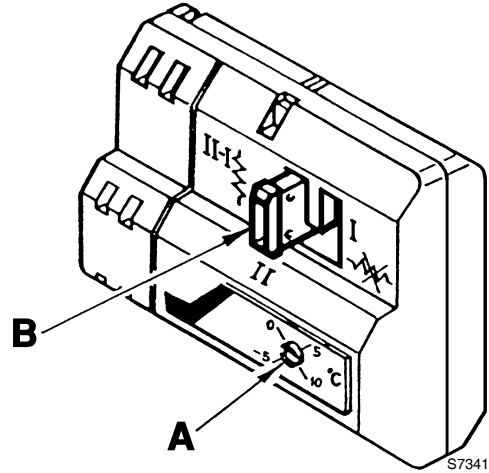

Fig. 25

Should the economizer be connected to an external probe, the operation at 1st or 2nd stage will be related to the external temperature.

When the external temperature is higher than the fixed value the economizer permits the burner operation only at 1st stage; on the contrary when the external temperature decreases in relation with the fixed value, the economizer permits the burner operation only at 2nd stage.

The external temperature causing the economizer intervention might be chosen between -5 °C and +10 °C, turning the setting screw **A** (Fig. 25) using the screw-driver.

For this type of operation the plug **B** (Fig. 25) has to be placed in the position **I-II**.

When the plug **B** is in the position **II** or **I**, the burner operates as previously indicated.

8.9 Burner start-up cycle

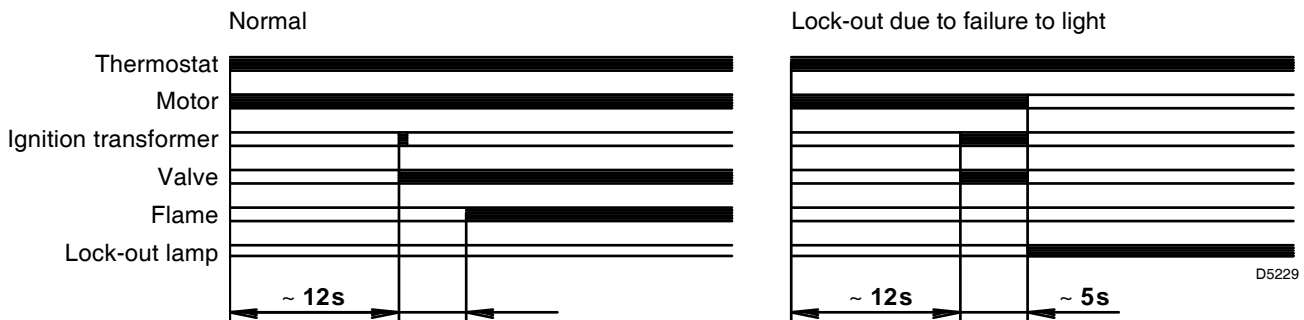

Fig. 26

9 Maintenance

9.1 Notes on safety for the maintenance

The periodic maintenance is essential for the good operation, safety, yield and duration of the burner.

It allows you to reduce consumption and polluting emissions and to keep the product in a reliable state over time.



The maintenance interventions and the calibration of the burner must only be carried out by qualified, authorised personnel, in accordance with the contents of this manual and in compliance with the standards and regulations of current laws.

Before carrying out any maintenance, cleaning or checking operations:



disconnect the electricity supply from the burner by means of the main switch of the system;



isolate the fuel supply.

9.2 Maintenance programme

9.2.1 Maintenance frequency

The combustion system should be checked at least once a year by a representative of the manufacturer or another specialised technician.

9.2.2 Maintenance position

Access to the combustion head, diffuser disc / electrodes unit and nozzle (Fig. 27)

- Remove the burner out of the boiler, after loosing the fixing nut to the flange.
- Hook the burner to the flange 1), by removing the combustion head 2) after loosing the fixing screws 3).
- Remove the diffuser disc-holder assembly 9) from the nozzle-holder 8) after loosing its fixing screw.
- Screw the nozzle 10).

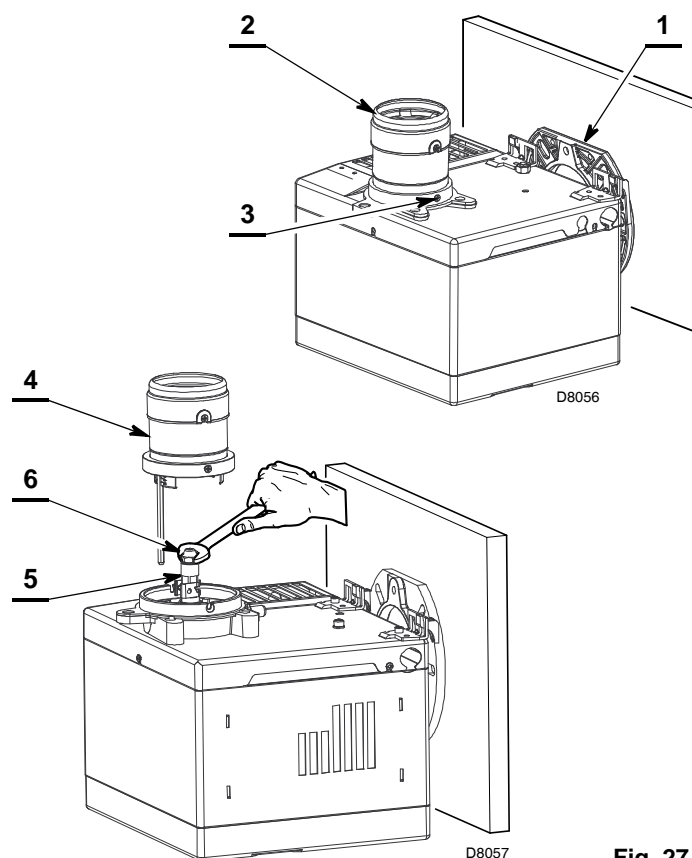

Fig. 27

9.2.3 Checking and cleaning

Combustion head

Open the burner and make sure that all components of the combustion head are in good condition, not deformed by the high temperatures, free of impurities from the surroundings and correctly positioned.

Clean the combustion head in the fuel exit area, on the diffuser disc.

Burner

Check for excess wear or loose screws and clean the outside of the burner.

Fan

Check to make sure that no dust has accumulated inside the fan or on its blades, as this condition will cause a reduction in the air flow rate and provoke polluting combustion.

Photoresistance

Clean the photoresistance.

Electrodes

Check the correct position of electrodes.

Nozzles

It is advisable to replace nozzles every year during regular maintenance operations.

Do not clean the nozzle openings; do not even open them.

Filters

Check the filtering baskets on line and at nozzle present in the system. Clean or replace if necessary.

If rust or other impurities are observed inside the pump, use a separate pump to lift any water and other impurities that may have deposited on the bottom of the tank.

Pump

Delivery pressure must correspond with the table on Tab. E at page 19. Please check that the supply line and filters are clear. The use of a pump vacuum gauge will assist in this. This measure permits the cause of the anomaly to be traced to either the suction line or the pump.

If the problem lies in the suction line, check to make sure that the filter is clean and that air is not entering the piping.

Hoses

- Check periodically the flexible pipes conditions. They have to be replaced at least **every 2 years**.
- In case of use of gas oil and bio fuel blends, it is strongly recommended to inspect **even more frequently** the hoses and replace them where contamination has occurred.
- Check to make sure that the hoses are still in good condition.



WARNING

In case of use with gas oil containing up to 30% Bio blend, it will be essential to use flexible oil lines suitable for bio fuel use.

Please contact Riello for further information.

Fuel tank

If water or contamination is present within the fuel tank, it is essential that this is removed before the equipment is to be used. This is extremely important when gas oil containing Bio diesel is in use. If in doubt about how to achieve this then please contact the fuel or oil tank supplier.

Boiler

Clean the boiler as indicated in its accompanying instructions in order to maintain all the original combustion characteristics intact, especially the flue gas temperature and combustion chamber pressure.

Combustion

In case the combustion values found at the beginning of the intervention do not respect the standards in force or, in any case, do not correspond to a proper combustion, contact the Technical Assistant and have him carry out the necessary adjustments.

Allow the burner to work for 10 min. and then check the combustion readings with the parameters indicated within the appliance instruction manual. **Then carry out a combustion check verifying:**

- Smoke temperature at the chimney;
- Content of CO₂ (%);
- Content of CO (ppm);
- Smoke value according to opacity smokes index according to Bacharach scale.

10 **Faults / Solutions**

Here below you can find some causes and the possible solutions for some problems that could cause a failure to start or incorrect operation of the burner.

A fault usually makes the lock-out lamp light which is situated inside the reset button of the control box (8, Fig. 1 to page 8).

When lock out lamp lights the burner will attempt to light only after pushing the reset button. After this if the burner functions correctly, the lock-out can be attributed to a temporary fault.

If however the lock out continues the cause must be determined and the solution found.

FAULTS	POSSIBLE CAUSES	SOLUTION
<p>The burner will not start when the limit thermostat closes.</p>	<p>Lack of electrical supply.</p>	<p>Check presence of voltage in the L - N clamps of the control box. Check the conditions of the fuses. Check that safety thermostat limit is not lock out.</p>
	<p>The photoresistance sees false light.</p>	<p>Eliminate the light.</p>
	<p>The connections in the control box are wrongly inserted.</p>	<p>Check and connect completely all the plugs.</p>
	<p>Burner runs normally in the prepurge and ignition cycle and locks out after 5 seconds ca.</p>	<p>The photoresistance is dirty.</p>
<p>The photoresistance is defective.</p>		<p>Change it.</p>
<p>Flame moves away or fails.</p>		<p>Check pressure and output of the fuel. Check air output. Change nozzle. Check the coil of solenoid valve.</p>
<p>Burner starts with an ignition delay.</p>	<p>The ignition electrodes are wrongly positioned.</p>	<p>Adjust them according to the instructions of this manual.</p>
	<p>Air output is too high.</p>	<p>Set the air output.</p>
	<p>Nozzle dirty or worn.</p>	<p>Replace it.</p>



The manufacturer cannot accept responsibility for any damage to persons, animals or property due to error in installation or in the burner adjustment, or due to improper or unreasonable use or non observance of the technical instruction enclosed with the burner, or due to the intervention of un-qualified personnel.

RIELLO

RIELLO S.p.A.
I-37045 Legnago (VR)
Tel.: +39.0442.630111
[http:// www.riello.it](http://www.riello.it)
[http:// www.rielloburners.com](http://www.rielloburners.com)