

RS 310-410-510-610/E-/EV-/EVi MZ SERIES

The RS 310-410-510-610/E-/EV-/EVi MZ burners series covers a firing range from 1300 to 6300 kW, and it has been designed for use in low or medium temperature hot water boilers, hot air or steam boilers, diathermic oil boilers.

It is based on the Digital Burner Management System, Riello REC27-37, which is able to manage the air-fuel ratio by independent servomotors in order to obtain a perfect output control and to assure a correct combustion and safe operation on all modulation range. Operation can be "two stage progressive" or, alternatively, "modulating" with the installation of a PID logic regulator and respective probes.

RS/E-/EV-/EVi MZ burners series guarantees high efficiency levels in all the various applications, thus reducing fuel consumption and running costs; specific versions are available to operate with **Variable Speed Drive technology** base on the control of a Frequency Inverter that modifies the air flow through the motor speed variation.

The RS/EVi models provide a Variable Speed Drive System integrated with the fan motor for a compact solution and an easy commissioning.

The exclusive design ensures reduced dimensions, simple use and maintenance.

A wide range of accessories guarantees elevated working flexibility.



RS 310/E-/EV-/EVi MZ	600/1300 ÷ 3900 kW
RS 410/E-/EV-/EVi MZ	800/2000 ÷ 4900 kW
RS 510/E-/EV-/EVi MZ	802/2200 ÷ 5250 kW
RS 610/E-/EV-/EVi MZ	820/2400 ÷ 6300 kW

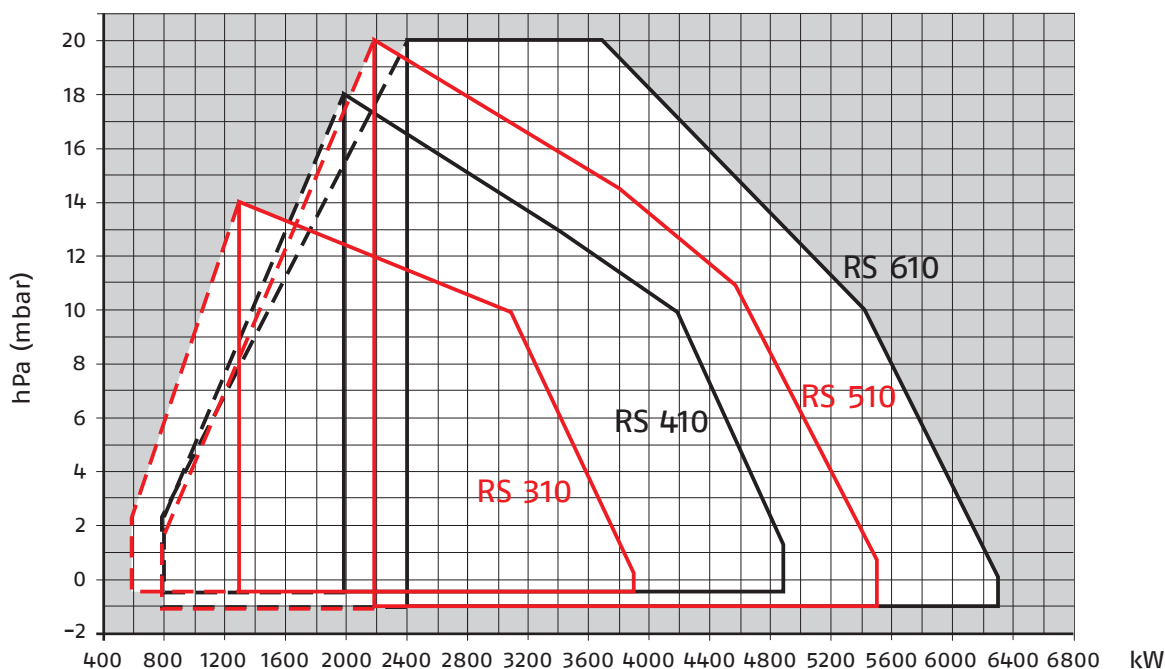

 Useful working field for choosing the burner

 Modulation range

Test conditions conforming to EN676
 Temperature: 20°C
 Pressure: 1013,5 mbar
 Altitude: 0 m a.s.l.

Modulating Gas Burners

RS 310-410-510-610/E-/EV-/EVi MZ SERIES

Overall dimensions (mm)

BURNERS

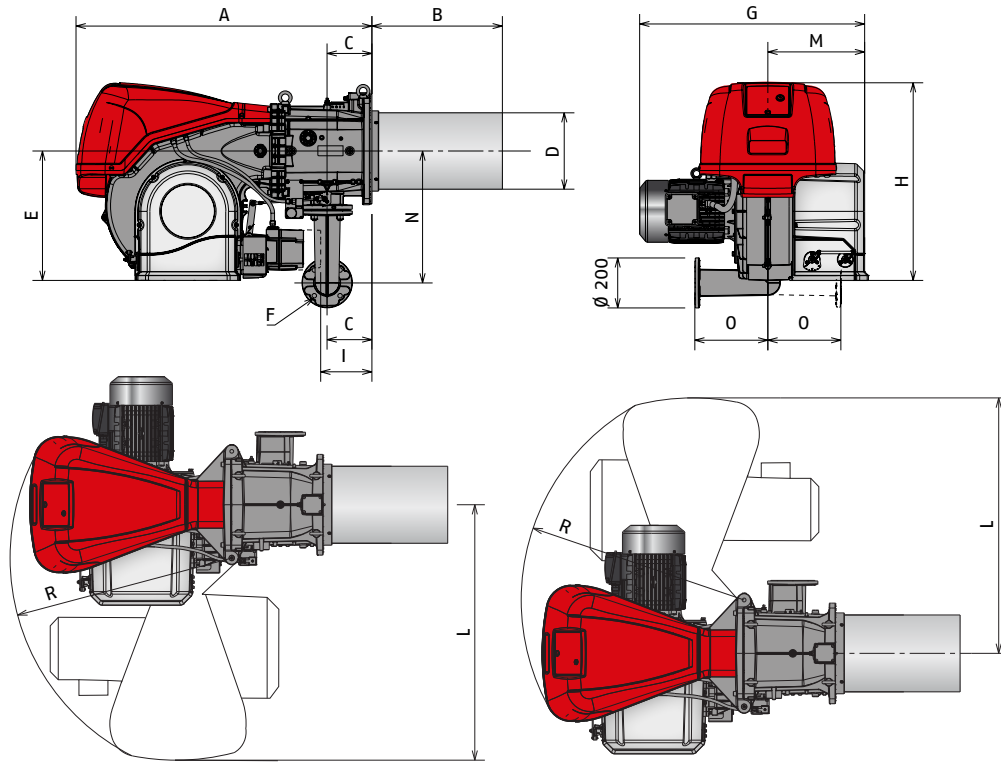

Model	A	B	C	D	E	F	G	H	I*	L	M	N	O	P	R
▶ RS 310/E-/EV-/EVi MZ	1178	519	178	306	520	DN65	890	790	177	1015	400	528	290	177	890
▶ RS 410/E-/EV-/EVi MZ	1178	519	178	306	520	DN65	908	790	177	1015	400	528	290	177	890
▶ RS 510/E-/EV-/EVi MZ	1178	519	178	306	520	DN65	908	790	177	1015	400	528	290	177	890
▶ RS 610/E-/EV-/EVi MZ	1178	519	178	330	520	DN65	980	790	177	1015	400	528	290	177	890

* Maximum position for the extraction of the servomotor cover in mechanical cam models.

BURNER - BOILER MOUNTING FLANGE

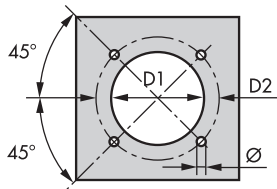

Model	D1	D2	Ø
▶ RS 310/E-/EV-/EVi	335	452	M18
▶ RS 410/E-/EV-/EVi	335	452	M18
▶ RS 510/E-/EV-/EVi	335	452	M18
▶ RS 610/E-/EV-/EVi	350	452	M18

PACKAGING

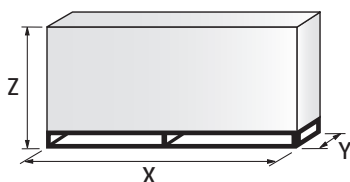

Model	X	Y	Z	kg
▶ RS 310/E-/EV-/EVi	2040	1180	1125	250
▶ RS 410/E-/EV-/EVi	2040	1180	1125	250
▶ RS 510/E-/EV-/EVi	2040	1180	1125	250
▶ RS 610/E-/EV-/EVi	2040	1180	1125	250

RS 310-410-510-610/E-/EV/-EVi MZ SERIES

Specification

DESIGNATION OF SERIES

A specific index guides your choice of burner from the various models available in the RS/M MZ series. Below is a clear and detailed specification description of the product.

Series: R									
Fuel: S Natural Gas									
L Light oil									
LS Light oil/Natural Gas									
N Heavy oil									
Size:									
Setting: /1 Single stage					/E Electronic cam				
/B Two stage					/P Proportioning air/gas valve				
/M Modulating-Mechanical cam					/EV Electronic cam predisposed for variable speed (with inverter available as a kit)				
					/EVi Electronic cam with integrated inverter				
Emission: ... or CO1					Class 1 EN267 - EN676				
MZ					Class 2 EN267 - EN676				
BLU					Class 3 EN267 - EN676				
MX					Class 2 EN267				
					Class 3 EN676				
Head length:					TC standard head				
					TL extended head				
Flame control system:					FS1 Standard (1 stop every 24 h)				
					FS2 Continuous working (1 stop every 72 h)				
Electrical supply to the system:									
1/230/50					1/230V/50Hz				
3/230/50					3/230V/50Hz				
3/400/50					3N/400V/50Hz				
3/230-400/50					3/230V/50Hz - 3N/400V/50Hz				
3/220/60					3/220V/60Hz				
3/380/60					3N/380V/60Hz				
3/220-380/60					3/220/60Hz - 3N/380V/60Hz				
Auxiliary voltage: 230/50-60 230V/50-60H									
110/50-60 110V/50-60Hz									
R	S	510	/E	MZ	TC	FS1	3/230-400/50	230/50-60	
BASIC DESIGNATION					EXTENDED DESIGNATION				

Specification

STATE OF SUPPLY

Monoblock forced draught burners with two stage progressive or modulating operation, with a specific kit, fully automatic, made up of:

- Microprocessor-based Digital Burner Management System (RS/E MZ models)
- Microprocessor-based Digital Burner Management System with Variable Speed Drive technology for the control of a Frequency Inverter (RS/EV-/EVi MZ models)
- Display Interface operating unit to adjust the system
- Air suction circuit lined with sound-proofing material
- High performance fan with low sound emissions, forward curve blades
- Air damper for air flow setting and butterfly valve for regulating fuel output controlled by independent stepper motor actuators
- Air pressure switch
- Fan starting motor at 2900 rpm, three-phase 230/400 - 400/690 V with neutral, 50 Hz
- Combustion head, that can be set on the basis of required output, fitted with:
 - stainless steel end cone, resistant to corrosion and high temperatures
 - ignition electrodes; ionisation sensor for flame detection (or UV sensor on demand)
 - flame stability disk
- Maximum gas pressure switch, with pressure test point, for halting the burner in the case of over pressure on the fuel supply line
- Star/delta starter for the fan motor (Direct starter fan motor for RS 310-410 models)
- Main electrical supply terminal board
- Burner on/off switch
- Manual or automatic output increase/decrease switch
- Contacts motor and thermal relay with release button
- Burner failure led signal and lighted release button
- Burner opening hinge
- Lifting rings
- IP 54 electric protection level

Standard equipment:

Gasket for gas train adaptor

Adaptor for gas train

Screws for fixing the gas train adaptor: M 16 x 70

Thermal insulation screen

M 18 x 60 screws to secure the burner flange to the boiler

Cable grommets kit for optional electrical wiring input

M16 x 6 studs for fixing the gas elbow to the pipe coupling

M16 nuts to fix the gas elbow to the pipe coupling

Instruction handbook for installation, use and maintenance

Spare parts catalogue

Gas train

Fuel supply line, in the MULTIBLOC configuration (for a diameter of 1-1/2" and 2") or COMPOSED configuration (from a diameter of DN 65 until a diameter of DN 125), fitted with:

- Filter
- Stabiliser
- Minimum gas pressure switch
- Safety valve
- One stage working valve with ignition gas output regulator.

RS 310-410-510-610/E-/EV/-EVi MZ SERIES

Specification

Conforming to:

- 2004/108 EC directive (electromagnetic compatibility)
- 2006/95 EC directive (low voltage)
- 2009/142 EC directive (gas)
- 2006/42 EC directive (machine)
- EN 676 (gas burners).

Available accessories to be ordered separately:

- Power controller
- Probe
- Continuous ventilation kit
- UV cell kit
- Variable speed drive (VSD) kit (for RS/EV series only)
- PC interface kit
- OCI412 Interface kit
- Sound proofing box
- Spacer kit
- Adapters
- PVP (Pressure Proving System)
- Stabiliser spring.

Modulating Gas Burners

RS 310-410-510-610/E-/EV/-EVi MZ SERIES

Available models

Burners

CODE	MODEL				HEAT OUTPUT NATURAL GAS		TOTAL ELECTRICAL POWER (KW)	CERTIFICATION	NOTE
					(KW)	(Nm ³ /h)			
20068349	RS 310/E MZ	TC	FS1	3/230/50	400/1200-3630	40/120-363	9,1	CE-0085C90166	
20068353	RS 310/E MZ	TC	FS1	3/400/50	400/1200-3630	40/120-363	9,1	CE-0085C90166	
20068026	RS 310/E MZ	TC	FS1	3/400/50	400/1200-3630	40/120-363	8,8	CE-0085C90166	(1)
20074260	RS 310/E MZ	TC	FS2	3/230/50	400/1200-3630	40/120-363	8,8	CE-0085C90166	
20074261	RS 310/E MZ	TC	FS2	3/400/50	400/1200-3630	40/120-363	9,1	CE-0085C90166	
20074264	RS 310/E MZ	TC	FS2	3/400/50	400/1200-3630	40/120-363	9,1	CE-0085C90166	(1)
20068358	RS 410/E MZ	TC	FS1	3/230/50	500/1500-4450	50/150-445	10,6	CE-0085C90166	
20068363	RS 410/E MZ	TC	FS1	3/400/50	500/1500-4450	50/150-445	10,6	CE-0085C90166	
20067961	RS 410/E MZ	TC	FS1	3/400/50	500/1500-4450	50/150-445	10,6	CE-0085C90166	(1)
20074262	RS 410/E MZ	TC	FS2	3/230/50	500/1500-4450	50/150-445	10,6	CE-0085C90166	
20074263	RS 410/E MZ	TC	FS2	3/400/50	500/1500-4450	50/150-445	10,6	CE-0085C90166	
20074265	RS 410/E MZ	TC	FS2	3/400/50	500/1500-4450	50/150-445	10,6	CE-0085C90166	(1)
20068028	RS 510/E MZ	TC	FS1	3/400/50	680/1800-5250	68/180-525	13,9	CE-0085C90166	(1)
20074266	RS 510/E MZ	TC	FS2	3/400/50	680/1800-5250	68/180-525	13,9	CE-0085C90166	(1)
20067963	RS 610/E MZ	TC	FS1	3/400/50	1000/2200-6250	100/220-625	16,9	CE-0085C90166	(1)
20074267	RS 610/E MZ	TC	FS2	3/400/50	1000/2200-6250	100/220-625	16,9	CE-0085C90166	(1)
20074274	RS 310/EV MZ	TC	FS1/FS2	3/230/50	400/1200-3630	40/120-363	9,1	In progress	
20074275	RS 310/EV MZ	TC	FS1/FS2	3/400/50	400/1200-3630	40/120-363	9,1	In progress	
20074276	RS 410/EV MZ	TC	FS1/FS2	3/230/50	500/1500-4450	50/150-445	10,8	In progress	
20074277	RS 410/EV MZ	TC	FS1/FS2	3/400/50	500/1500-4450	50/150-445	10,8	In progress	
20074278	RS 510/EV MZ	TC	FS1/FS2	3/400/50	680/1800-5250	68/180-525	14	In progress	
20074279	RS 610/EV MZ	TC	FS1/FS2	3/400/50	1000/2200-6250	100/220-625	17	In progress	
20090490	RS 310/EVi MZ	TC	FS1/FS2	3/400/50	400/1200-3630	40/120-363	9,1	In progress	
20090384	RS 410/EVi MZ	TC	FS1/FS2	3/400/50	500/1500-4450	50/150-445	10,8	In progress	
20089352	RS 510/EVi MZ	TC	FS1/FS2	3/400/50	680/1800-5250	68/180-525	14	In progress	
20089013	RS 610/EVi MZ	TC	FS1/FS2	3/400/50	1000/2200-6250	100/220-625	17	In progress	

Natural gas, net calorific value: 10 kWh/Nm³ - Density: 0,71 kg/Nm³

The burners of RS/E-/EV-/EVi MZ series are in according to 2009/142 - 2004/108 - 2006/95 - 2006/42 EC Directives.

(1) Star delta starter

RS 310-410-510-610/E-/EV/-EVi MZ SERIES

Available models

Gas Trains

CODE	GAS TRAIN		ADAPTER CODE			
	MODEL	∅	RS 310	RS 410	RS 510	RS 610
3970250*	MB 415/1 - RT 52	Rp 1" 1/2	3000826 + 20064220	●	●	●
3970257*	MB 420/1 - RT 52	Rp 2"	3000826 + 20042324	●	●	●
3970221*	MBC 1200/1 - RSM 60	Rp 2"	3000826 + 20042324			
3970222*	MBC 1900/1 - FSM 40	DN 65	3010221			
3970223*	MBC 3100/1 - FSM 40	DN 80	3010222			
3970224*	MBC 5000/1 - FSM 80	DN 100	3010222 - 3010370			
3970145*	CB 512/1 - RSM 30	Rp 1" 1/2	3000826 + 20064220		●	●
3970146*	CB 520/1 - RSM 30	Rp 2"	3000826 + 20042324			●
20044659*	CB 525/1 - RSM 30	Rp 2"	3000826 + 20042324			
3970147*	CB 5065/1 - FSM 30	DN 65	3010221			
3970148*	CB 5080/1 - FSM 30	DN 80	3010222			
3970149*	CB 50100/1 - FSM 30	DN 100	3010223 - 3010370			
20015871*	CB 50125/1 - FSM 30	DN 125	3010224			

Please see designation of Gas Train Series in the page before the Catalogue index.

* 230V/50Hz -220V/60Hz electrical supply.

** 230V/50Hz electrical supply.

The valves seal control device is compulsory (conforming to EN 676) on gas trains to burners with a maximum output over 1200 kW.

The seal control function is managed by REC control box, by installation on gas train of a pressure switch (please see Gas train accessories paragraph).

To select the gas train please refer to the technical data leaflet and/or instruction manual.

● Not available.

Modulating Gas Burners

RS 310-410-510-610/E-/EV-/EVi MZ SERIES

Burner accessories

Accessories for modulating operation

POWER CONTROLLER



To obtain modulating operation, the RS/E/EV/EVi MZ series of burners requires a regulator with three point outlet controls. The following table lists the accessories for modulating operation with their application range.

BURNER	TYPE	CODE
► All models	RWF 50.2 - Basic version with 3 position output	20073595
	RWF 55.5 - Complete with RS-485 interface	20074441
	RWF 55.6 - Complete with RS-485/ PROFIBUS interface	20074442

PROBE



The relative temperature or pressure probes fitted to the power controller must be chosen on the basis of the application.

BURNER	TYPE	RANGE (°C) (BAR)	CODE
► All models	Temperature PT 100	-100 ÷ 500°C	3010110
	Pressure 4 ÷ 20 mA	0 ÷ 2,5 bar	3010213
	Pressure 4 ÷ 20 mA	0 ÷ 16 bar	3010214
	Pressure 4 ÷ 20 mA	0 ÷ 16 bar	3090873

Continuous ventilation kit



If the burner requires continuous ventilation in the stages without flame, a special kit is available as given in the following table:

BURNER	CODE
► RS 310-410-510-610/E	20077810

Uv cell kit



A UV cell is available for the supervision of the flame alternatively to ionisation probe for special applications.

BURNER	CODE
► RS 310-410-510-610/E-/EV-/EVi	20077814

Pc interface kit



To connect the control panel to a personal computer for the transmission of operation, fault signals and detailed service information, an interface adapter with PC software are available.

BURNER	CODE
► RS 310-410-510-610/E-/EV-/EVi (ACS410 + OCI410.30) - Service level	3010436

RS 310-410-510-610/E-/EV/-EVi MZ SERIES

Burner accessories

Variable Speed Drive (VSD) for RS/EV series only



The motor speed variation for the RS/EV BLU burners series is obtained thanks to a frequency converter: variable speed drive (VSD), provided with a programming panel with start-up assistant. It always must be ordered with RS/EV series.

BURNER	ELECTRICAL SUPPLY	MOTOR POWER (kW)	INVERTER POWER (kW)	KIT CODE
▶ RS 310/EV	230	7,5	7,5	20083590
▶ RS 310/EV	400	7,5	7,5	20028307
▶ RS 410/EV	230	9,2	11	20083611
▶ RS 410/EV	400	9,2	11	3090952
▶ RS 510/EV	400	12	15	3090960
▶ RS 610/EV	400	15	15	3090960

The use of inverters other than those indicated by the manufacturer may lead to burner failure and, in extreme cases, a potential risk of harm to people and damage to property. The manufacturing company shall not be liable for any such damage arising from non-observance of the requirements contained in the burner manual.

OCI412 interface kit



Interface kit between the REC 27.1 and a Modbus system, such as a building automation and control system (BACS). The Modbus interface is based on the RS-485 standard.

BURNER	CODE
▶ RS 310-410-510-610/E-/EV-/EVi	3010437

Sound proofing box

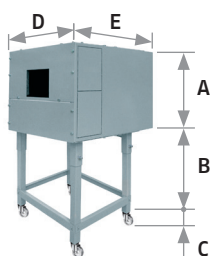

If noise emission needs reducing even further, sound-proofing boxes are available. In case of generator heights, where a lower dimension "B" is required, ask for the Box Support Kit code 20065135. The useful dimensions are 40 mm less than the total dimensions indicated in the table (A, D, E). Not suitable for outdoor use.

BURNER	BOX TYPE	A (mm)	B (mm) min. - max	C (mm)	D (mm)	E (mm)	[dB(A)] (*)	CODE
▶ All models	C7	1255	160 - 980	110	1140	1345	10	3010376

(*) Average noise reduction according to EN 15036-1 standard

Spacer kit

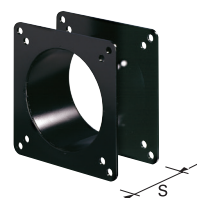





If burner head penetration into the combustion chamber needs reducing, varying thickness spacers are available, as given in the following table:

BURNER	Spacer thickness S (mm)	CODE
▶ All models	180	20008903

Gas train accessories

Adapters

In certain cases, an adapter must be fitted between the gas train and the burner, when the diameter of the gas train is different from the set diameter of the burner. Below are given the available adapters; please see on the Gas Train list the correct adapter codes to select.

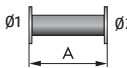
ADAPTER	DIMENSIONS		ADAPTER CODE		
	ø1 DN	ø2 DN		A mm	B mm
1" 1/2  2"	-	-	65	-	20064220
2"  2"	-	-	65	-	20042324
DN 80  2" 1/2  2"	-	-	300	-	3000826
	65	80	400	-	3010221
	80	80	400	-	3010222
	100	80	400	-	3010223
	125	80	320	-	3010224

PVP (pressure valve proving kit)*

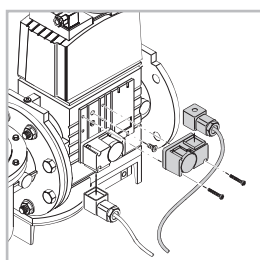

The seal control function is included on Burner Digital Management System, it is only necessary to add the PVP kit on the gas train.

GAS TRAIN	CODE
► MB - CB - MBC type	3010344

RS 310-410-510-610/E-/EV/-EVi MZ SERIES

Stabiliser spring



To vary the pressure range of the gas train stabilisers, accessory springs are available. The following table shows these accessories with their application range. Please refer to the technical manual for the correct choice of spring.

GAS TRAIN	SPRING COLOUR	SPRING Pressure range mbar	SPRING CODE
MBC 1900/1 - 3100/1 MBC 5000/1	White	4 - 20	3010381
	Red	20 - 40	3010382
	Black	40 - 80	3010383
CB 512/1	Green	80 - 150	3010384
	Red	25 - 55	3010131
	Black	60 - 110	3010157
	Pink	90 - 150	3090486
CB 520/1 - 525/1	Red	25 - 55	3010132
	Black	60 - 110	3010158
	Pink	100 - 150	3090487
CB 5065/1 - 5080/1	Red	25 - 55	3010133
	Black	60 - 110	3010135
	Pink	100 - 150	3090456
	Grey	140 - 200	3090992
CB 50100/1	Red	25 - 55	3010134
	Black	60 - 110	3010136
	Pink	100 - 150	3090489
	Grey	140 - 200	3092174
	Red	25 - 55	3010315
CB 50125/1	Yellow	30 - 70	3010316
	Black	60 - 110	3010317
	Pink	100 - 150	3010318