

- I** Bruciatori di gasolio
- GB** Light oil burners
- F** Brûleurs fioul domestiques
- D** Öl-Gebläsebrenner
- E** Quemadores de gasóleo

Funzionamento bistadio
Two-stage operation
Fonctionnement à deux allures
Zweistufiger Betrieb
Funcionamiento de dos llama

CODICE - CODE CÓDIGO	MODELLO - MODEL - MODELE MODELL - MODELO	TIPO - TYPE - TYP
3474520	PRESS 1G	606 T1
3474920	PRESS 2G	607 T1

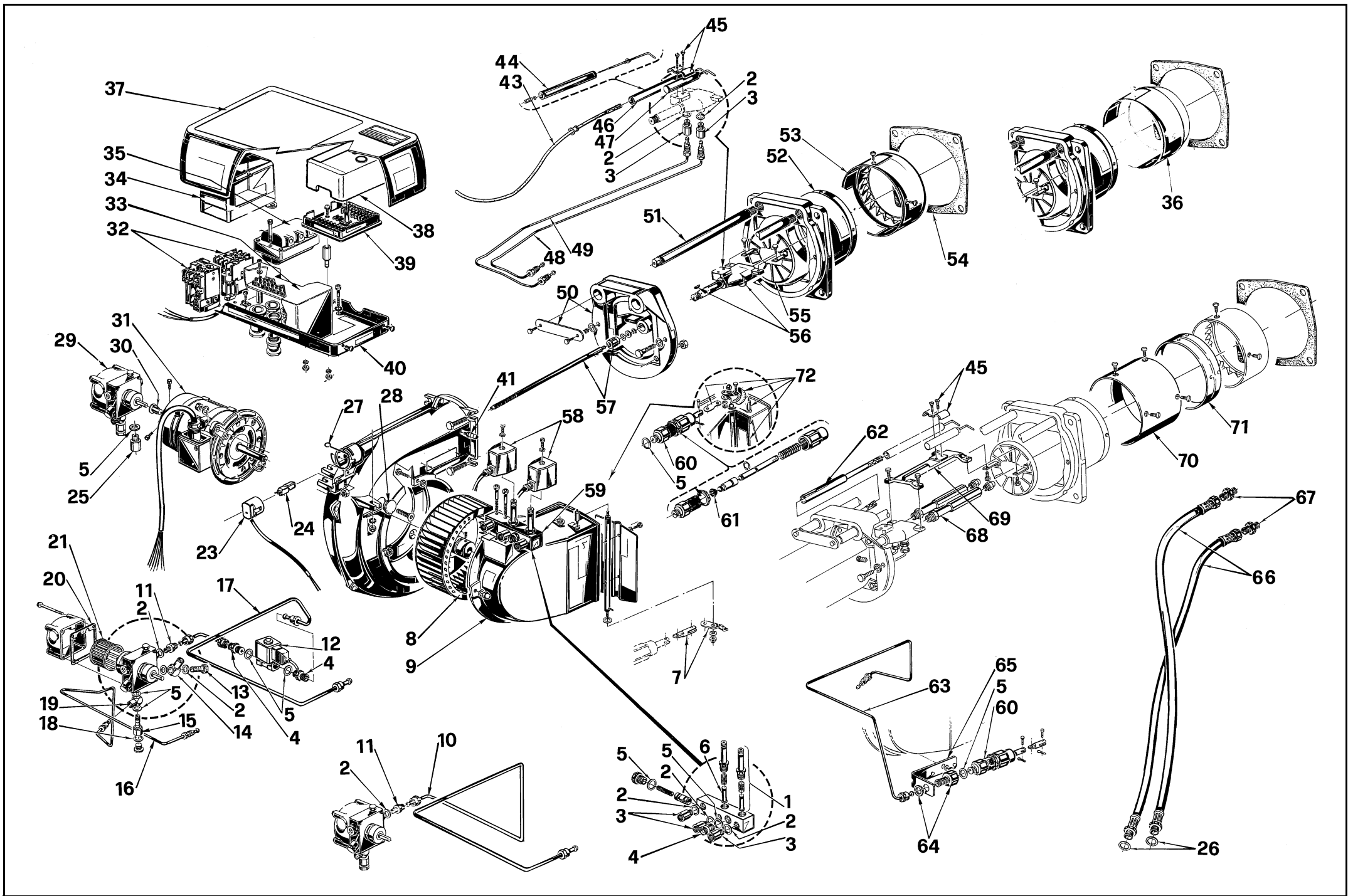

N.	COD.	3474520 3474920	DESCRIZIONE	DESCRIPTION	DESCRIPTION	BESCHREIBUNG	DENOMINACION	MATRICOLA BRUCIATORE BURNER SERIAL NUMBER MATRICULE BRULEUR BRENNER KENN-NUMMER MATRICULA QUEMADÓRES	**
1	3005733	• •	VALVOLA	NEEDLE VALVE	ROBINET POINTEAU	NADELVENTIL	VÁLVULA		
2	3007077	• •	GUARNIZIONE	SEAL	RONDELLE	METALLDICHTUNG	JUNTA		B
3	3006719	• •	RACCORDO	CONNECTOR	MAMELON	NIPPEL	RACORD		C
4	3006723	• •	RACCORDO	CONNECTOR	MAMELON	NIPPEL	RACORD		C
5	3007079	• •	GUARNIZIONE	SEAL	RONDELLE	METALLDICHTUNG	JUNTA		B
6	3006038	• •	SILLO	PIN	NOYAU ELECTROVANNE	KERN	CONTACTO		
7									
8	3005443	•	GIRANTE	FAN	TURBINE	GEBLÄSERAD	TURBINA		C
8	3005444	•	GIRANTE	FAN	TURBINE	GEBLÄSERAD	TURBINA		C
9	3003361	•	BOCCA D'ASPIRAZIONE	AIR INTAKE	BOITIER D'ASPIRATION	ANSAUGÖFFNUNG	BOCA ASPIRACION		
9	3003362	•	BOCCA D'ASPIRAZIONE	AIR INTAKE	BOITIER D'ASPIRATION	ANSAUGÖFFNUNG	BOCA ASPIRACION		
10	3006765	•	TUBO	TUBE	TUYAUTERIE	DRUCKROHR	TUBO		
10	3006737	•	TUBO	TUBE	TUYAUTERIE	DRUCKROHR	TUBO		
11	3006720	• •	RACCORDO	CONNECTOR	MAMELON	NIPPEL	RACORD		C
12									
13									
14									
15	3006783	• •	RACCORDO	CONNECTOR	MAMELON	NIPPEL	RACORD		C
16	3006763	•	TUBO	TUBE	TUYAUTERIE	DRUCKROHR	TUBO		
16	3006738	•	TUBO	TUBE	TUYAUTERIE	DRUCKROHR	TUBO		
17									
17									
18	3007082	• •	GUARNIZIONE	SEAL	RONDELLE	METALLDICHTUNG	JUNTA		B
19	3006784	• •	RACCORDO	CONNECTOR	MAMELON	NIPPEL	RACORD		C
20	3003081	• •	GUARNIZIONE	SEAL	JOINT COUVERCLE POMPE	PUMPENDICHTUNG	JUNTA		A
21	3006801	• •	FILTRO	FILTER	FILTRE	PUMPENFILTER	FILTRO		A
22									
23	3006441	• •	PRESA	HOLDER	PRISE CELLULE	SOCKEL	CONECTOR		C
24	3002280	• •	FOTORESISTENZA	P.E. CELL	CELLULE	FOTOWIDERSTAND	FOTORESISTENCIA		A
25	3005739	• •	RACCORDO	CONNECTOR	MAMELON	NIPPEL	RACORD		C
26	3007088	• •	GUARNIZIONE	SEAL	RONDELLE	METALLDICHTUNG	JUNTA		A
27	3003325	• •	FERMO	SPRING LOCK	RESSORT D'APPUI	SICHERUNGSFEDER	DETENCION		
28	3003406	• •	PROTEZIONE	GRID	PROTECTION	SCHUTZGITTER	PROTECCIÓN		
29	3006712	• •	POMPA	PUMP	POMPE	PUMPE	BOMBA		C

N.	COD.	3474520 3474920	DESCRIZIONE	DESCRIPTION	DESCRIPTION	BESCHREIBUNG	DENOMINACION	MATRICOLA BRUCIATORE BURNER SERIAL NUMBER MATRICULE BRULEUR BRENNER KENN-NUMMER MATRICULA QUEMADÓRES	**
30	3006718	• •	GIUNTO	JOINT	ACCOUPLMENT	KUPPLUNG	CONJUNTO		A
31	3006716	•	MOTORE	MOTOR	MOTEUR	MOTOR	MOTOR		C
31	3006618	•	MOTORE	MOTOR	MOTEUR	MOTOR	MOTOR		C
32	3003565	•	AVVIATORE	STARTER	DEMARREUR	ANLASSER	ARRANCADOR		C
32	3003566	•	AVVIATORE	STARTER	DEMARREUR	ANLASSER	ARRANCADOR		C
33	3003071	• •	COPERCHIO	COVER	COUVERCLE	PVC ABDECKUNG	TAPA		
34	3003072	• •	COPERCHIO	COVER	COUVERCLE	PVC ABDECKUNG	TAPA		
35	3012159	• •	TRASFORMATORE	TRANSFORMER	TRANSFORMATEUR	ZÜNDTRANSFORMTOR	TRANSFORMADOR		B
36									
36									
37	3003387	• •	COPERCHIO	COVER	COUVERCLE	DECKEL	TAPA		
38	3013071	• •	APPARECCHIATURA	CONTROL BOX	BOITE DE CONTROLE	STEUERGERÄT	CAJA CONTROL		B
39	3003784	• •	MORSETTIERA	CONTROL BOX BASE	SOCLE	STECKSOCKEL	ZOCALO CAJA CONTROL		C
40	3003328	• •	MENSOLA	BASE PLATE	PLAQUE DE SUPPORT	GRUNDPLATTE	SOPORTE		
41	3003322	• •	RACCORDO	CONNECTOR	MAMELON	NIPPEL	RACORD		C
42	3000609	•	GRUPPO SERRANDA	AIR DAMPER ASSEMBLY	GROUPE VOLET AIR	LUFTKLAPPE	REGISTRO AIRE		
42									
42	3000610	•	GRUPPO SERRANDA	AIR DAMPER ASSEMBLY	GROUPE VOLET AIR	LUFTKLAPPE	REGISTRO AIRE		
42									
43	3003794	• •	COLLEGAMENTO	H.T. LEAD	CABLE H.T.	ZÜNDKABEL	CABLE ALTA TENSION		A
44	3004843	• •	ISOLATORE	INSULATOR	PORCELAINE D'ELECTRODE	ISOLATOR	AISLADOR		A
45	3003495	• •	CAVALLOTTO	U BOLT	CAVALIER	BÜGELBOLZEN	FIJACION ELECTRODO		
46	3004842	• •	ELETTRODO	ELECTRODE	ELECTRODE PORCELAINE	ELEKTRODE	ELECTRODO		A
47	3005490	• •	ELETTRODO DI MASSA	EARTH ELECTRODE	ELECTRODE MASSE	MASSE ELEKTRODE	ELECTRODO DE TIERRA		A
48	3006734	•	TUBO	TUBE	TUYAUTERIE	DRUCKROHR	TUBO		
48	3006740	•	TUBO	TUBE	TUYAUTERIE	DRUCKROHR	TUBO		
49	3006735	•	TUBO	TUBE	TUYAUTERIE	DRUCKROHR	TUBO		
49	3006741	•	TUBO	TUBE	TUYAUTERIE	DRUCKROHR	TUBO		
50	3003687	• •	COLLARE	COLLAR	COLLIER	INNERER FLANSCH	COLLARÍN		
51	3003688	• •	PERNO	BAR	GLISSIERE	BOLZEN	GUIA		
52	3005542	•	BOCCAGLIO	BLAST TUBE	GUEULARD	BRENNERFLANSCH	TUBO LLAMA		
52	3005545	•	BOCCAGLIO	BLAST TUBE	GUEULARD	BRENNERFLANSCH	TUBO LLAMA		
53	3005498	•	IMBUTO FIAMMA	END CONE	EMBOU GUEULARD	FLAMMENROHR	TUBO EXTREMO		B
53	3005502	•	IMBUTO FIAMMA	END CONE	EMBOU GUEULARD	FLAMMENROHR	TUBO EXTREMO		B
54	3005741	• •	SCHERMO	FLANGE GASKET	ECRAN THERMIQUE	FLANSCHDICHTUNG	JUNTA AISLANTE		A

N.	COD.	3474520	3474920	DESCRIZIONE	DESCRIPTION	DESCRIPTION	BESCHREIBUNG	DENOMINACION	MATRICOLA BRUCIATORE BURNER SERIAL NUMBER MATRICULE BRULEUR BRENNER KENN-NUMMER MATRICULA QUEMADORES	**
55	3005499	•		ELICA	DIFFUSER DISC	ACCROCHE FLAMME	STAUSCHEIBE	DISCO ESTABILIZADOR		A
55	3005503	•		ELICA	DIFFUSER DISC	ACCROCHE FLAMME	STAUSCHEIBE	DISCO ESTABILIZADOR		A
56	3005520	•	•	PORTASPRUZZO	NOZZLE HOLDER	PULVERISATEUR	DÜSENSTOCK	PORTABOQUILLA		C
57	3003689	•		ALBERO	SHAFT	ARBRE	WELLE	EJE		
57	3003690	•		ALBERO	SHAFT	ARBRE	WELLE	EJE		
58	3006714	•	•	BOBINA	COIL	BOBINE E.V.	MV-SPULE	BOBINA		B
59	3005492	•	•	GRUPPO VALVOLE	VALVE ASSEMBLY	GROUPE ELECTROVANNE	MAGNETVENTILBLOCK	CONJUNTO VÁLVULAS		B
60	3005493	•	•	MARTINETTO	HYDRAULIC JACK	VERIN AIR	DRUCKKOLBEN FÜR LUFT- KLAPPE	HIDRÁULICO		C
61	3007132	•	•	ANELLO DE	DE RING	JOINT	DE RING	ANILLO DE		B
*	62	3000478	•	•	PROLUNGA ELETTRODO	ELECTRODE EXTENSION	RALLONGE ELECTRODE	ELEKTRODE VER- LÄNGERUNG	PROLUNGACIÓN ELEC- TRODO	
	63									
	63									
	64									
	65									
	65									
	66	3009055	•	•	TUBO FLESSIBILE	FLEXIBLE OIL LINE	FLEXIBLE	SCHLAUCH	TUBO FLEXIBLE	A
	67	3009068	•	•	RACCORDO	CONNECTOR	MAMELON	NIPPEL	RACORD	C
*	68	3000472	•		PROLUNGA	EXTENSION	RALLONGE	VERLÄNGERUNG	PROLUNGACIÓN	
*	68	3000473	•		PROLUNGA	EXTENSION	RALLONGE	VERLÄNGERUNG	PROLUNGACIÓN	
*	69	3000566	•		SUPPORTO ELETTRODI	ELECTRODE BRACKET	SUPPORT ELECTRODES	ELEKTRODEN HALTERUNG	CORCHETE DEL ELECTRODO	
*	69	3000569	•		SUPPORTO ELETTRODI	ELECTRODE BRACKET	SUPPORT ELECTRODES	ELEKTRODEN HALTERUNG	CORCHETE DEL ELECTRODO	
*	70	3000565	•		CILINDRO	SLEEVE	CYLINDRE	ZYLINDER	CILINDRO	C
*	70	3000568	•		CILINDRO	SLEEVE	CYLINDRE	ZYLINDER	CILINDRO	C
*	71	3000564	•		DENTE	CONNECTION	JONCTION	STAURING	ANILLO LLAMA	
*	71	3000567	•		DENTE	CONNECTION	JONCTION	STAURING	ANILLO LLAMA	

*

Versione Testa Lunga - Long Combustion Head Version - Version Tête Longue - Langer Brennkopf Ausführung - Versión alargado de tubo llama

**

RICAMBI CONSIGLIATI - ADVISED PARTS - RECHANGE CONSEIL - EMPFOHLENE ERSATZTEILE - RECAMBIOS ACONSEJADOS

A = Ricambi per dotazione minima - Spare parts for minimum fittings - Pièces détachées pour équipement minimum - Ersatzteile für minimale Ausstattung - Recambios para equipamiento mínimo

A+B = Ricambi per dotazione base di sicurezza - Spare parts for basic safety fittings - Pièces détachées pour équipement standard de sécurité - Ersatzteile für Sicherheitsgrundausrüstung - Recambios para equipamiento básico de seguridad

A+B+C = Ricambi per dotazione estesa di sicurezza - Spare parts for extended safety fittings - Pièces détachées pour équipement complet de sécurité - Ersatzteile für erweiterte Sicherheitsausstattung - Recambios para equipamiento general de seguridad

RIELLO

RIELLO S.p.A.
I-37045 Legnago (VR)
Tel.: +39.0442.630111
[http:// www.riello.it](http://www.riello.it)
[http:// www.rielloburners.com](http://www.rielloburners.com)