

- I** Bruciatori di gasolio
- GB** Light oil burners
- F** Brûleurs fioul domestiques
- D** Öl-Gebläsebrenner
- E** Quemadores de gasóleo

Funzionamento bistadio
Two-stage operation
Fonctionnement à deux allures
Zweistufiger Betrieb
Funcionamiento de dos llama

CODICE - CODE CÓDIGO	MODELLO - MODEL - MODELE MODELL - MODELO	TIPO - TYPE - TYP
3475920	PRESS 3G	608 T1

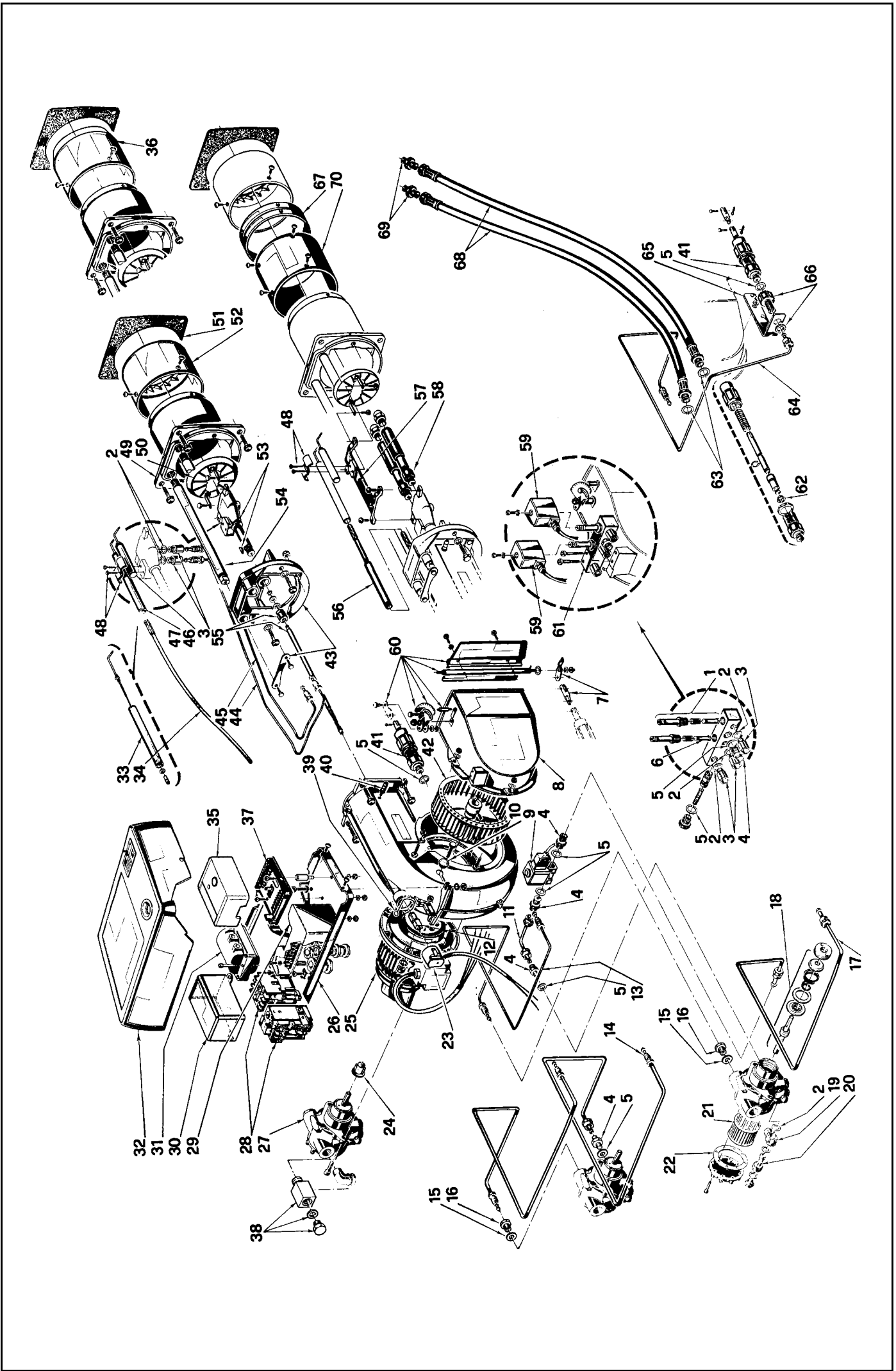

N.	COD.	DESCRIZIONE	DESCRIPTION	DESCRIPTION	BESCHREIBUNG	DENOMINACION	MATRICOLA BRUCIATORE BURNER SERIAL NUMBER MATRICULE BRULEUR BRENNER KENN-NUMMER MATRICULA QUEMADORES	RICAMBI CONSIGLIATI ADVISED PARTS RECHARGE CONSEIL EMPFOHLENE ERSATZTEILE RECAMBIOS A CONSEJADOS
								**
1	3005733	VALVOLA	NEEDLE VALVE	ROBINET POINTEAU	NADELVENTIL	VÁLVULA		
2	3007077	GUARNIZIONE	SEAL	RONDELLE	META DICHTUNG	JUNTA		B
3	3006719	RACCORDO	CONNECTOR	MAMELON	NIPPEL	RACORD		C
4	3006723	RACCORDO	CONNECTOR	MAMELON	NIPPEL	RACORD		C
5	3007079	GUARNIZIONE	SEAL	RONDELLE	METALLDICHTUNG	JUNTA		B
6	3006038	SPILLO	PIN	NOYAU ELECTROVANNE	KERN	CONTACTO		
7								
8	3003363	BOCCA D'ASPIRAZIONE	AIR INTAKE	BOITIER D'ASPIRATION	ANSAUGÖFFNUNG	BOCA ASPIRACIÓN		
9								
10	3003406	PROTEZIONE	GRID	PROTECTION	SCHUTZGITTER	PROTECCIÓN		
11								
12	3002280	FOTO RESISTENZA	P.E. CELL	CELLULE	FOTOWIDERSTAND	FOTORESISTENCIA		A
13	3003442	TUBO	TUBE	TUYAUTERIE	DRUCKROHR	TUBO		
14	3003441	TUBO	TUBE	TUYAUTERIE	DRUCKROHR	TUBO		
15	3007081	GUARNIZIONE	SEAL	RONDELLE	METALLDICHTUNG	JUNTA		B
16	3006786	RACCORDO	CONNECTOR	MAMELON	NIPPEL	RACORD		C
17								
18	3000805	ORGANO DI TENUTA	PUMP SEAL	ORGANE D'ETANCHEITE	WELLENDICHTUNG	CONJUNTO ESTANQUIDAD		
19								
20	3005771	PERNO	SCREW	VIS CREUSE	HOHLKERNSCHRAUBE	JUNTA		
21	3006787	FILTRO	FILTER	FILTRE	PUMPENFILTER	FILTRO		A
22	3006292	GUARNIZIONE	SEAL	JOINT COUVERCLE POMPE	PUMPENDICHTUNG	JUNTA		A
23	3006441	PRESA	HOLDER	PRISE CELLULE	SOCKEL	CONECTOR		C
24	3003440	GIUNTO	JOINT	ACCOUPLLEMENT	KUPPLUNG	CONJUNTO		A
25	3003439	MOTORE	MOTOR	MOTEUR	MOTOR	MOTOR		C
26	3003328	MENSOLA	BASE PLATE	PLAQUE DE SUPPORT	GRUNDPLATTE	SOPORTE		
27	3006713	POMPA	PUMP	POMPE	PUMPE	BOMBA		C
28	3003567	AVVIATORE	STARTER	DEMARREUR	ANLASSER	ARRANCADOR		C
29	3003071	COPERCHIO	COVER	COUVERCLE	PVC ABDECKUNG	ENVOLVENTE		
30	3003072	COPERCHIO	COVER	COUVERCLE	PVC ABDECKUNG	ENVOLVENTE		
31	3012159	TRASFORMATORE	TRANSFORMER	TRANSFORMATEUR	ZÜNDTRANSFORMATOR	TRANSFORMADOR		B
32	3003387	COPERCHIO	COVER	COUVERCLE	DECKEL	ENVOLVENTE		
33	3004843	ISOLATORE	INSULATOR	PORCELAINE D'ELECTRODE	ISOLATOR	AISLADOR		A
34	3003972	COLLEGAMENTO	H.T. LEAD	CABLE H.T.	ZÜNDKABEL	CABLE ALTA TENSION		A
35	3013071	APPARECCHIATURA	CONTROL BOX	BOITE DE CONTROLE	STEUERGERÄT	CAJA CONTROL		B
36								
37	3003784	MORSETTIERA	CONTROL BOX BASE	SOCLE	STECKSOCKEL	ZOCALO CAJA CONTROL		C
38	3003681	RACCORDO	CONNECTOR	MAMELON	NIPPEL	RACORD		C
39	3003325	FERMO	SPRING LOCK	RESSORT D'APPUI	SICHERUNGSFEDER	DETECCIÓN		
40	3003322	RACCORDO	CONNECTOR	MAMELON	NIPPEL	RACORD		C
41	3005493	MARTINETTO	HYDRAULIC JACK	VERIN AIR	DRUCKKOLBEN FÜR LUFTKLAPPE	HIDRÁULICO		C
42	3005460	GIRANTE	FAN	TURBINE	GEBLÄSERAD	TURBINA		C
43	3003677	COLLARE	COLLAR	COLLIER	INNERER FLANSCH	COLLARÍN		
44	3006742	TUBO	TUBE	TUYAUTERIE	DRUCKROHR	TUBO		

N.	COD.	DESCRIZIONE	DESCRIPTION	DESCRIPTION	BESCHREIBUNG	DENOMINACION	MATRICOLA BRUCIATORE BURNER SERIAL NUMBER MATRICULE BRULEUR BRENNER KENN-NUMMER MATRICULA QUEMADORES	RICAMBI CONSIGLIATI ADVISED PARTS RECHARGE CONSEIL EMPFOHLENE ERSATZTEILE RECAMBIOS ACONSEJADOS
								**
45	3006743	TUBO	TUBE	TUYATERIE	DRUCKROHR	TUBO		
46	3005490	ELETTRODO DI MASSA	EARTH ELECTRODE	ELECTRODE MASSE	MASSE ELEKTRODE	ELETTRODO DE TIERRA		A
47	3004842	ELETTRODO	ELECTRODE	ELECTRODE PORCELAIN	ELEKTRODE	ELETTRODO		A
48	3003495	CAVALLOTTO	U BOLT	CAVALIER	BÜGELBOLZEN	FIJACION ELECTRODO		
49	3005472	BOCCAGLIO	BLAST TUBE	GUEULARD	BRENNERFLANSCH	TUBO LLAMA		
50	3005539	ELICA	DIFFUSER DISC	ACCROCHE FLAMME	STAUSSCHEIBE	DISCO ESTABILIZADOR		A
51	3005742	SCHERMO	FLANGE GASKET	ECRAN THERMIQUE	FLANSCHDICHTUNG	JUNTA AISLANTE		A
52	3005540	IMBUTO FIAMMA	END CONE	EMBOUT GUEULARD	FLAMMENROHR	TUBO EXTREMO		B
53	3005520	PORTASPRUZZO	NOZZLE HOLDER	PULVERISATEUR	DÜSENSTOCK	PORTABOQUILLA		C
54	3003678	PERNO	BAR	GLISSIERE	BOLZEN	GUIA		
55	3003679	ALBERO	SHAFT	ARBRE	WELLE	EJE		
*56	3000478	PROLUNGA ELETTRODO	ELECTRODE EXTENSION	RALLONGE ELECTRODE	ELEKTRODE VERLÄNGERUNG	PROLUNGACIÓN ELECTRODO		A
*57	3000566	SUPPORTO ELETTRODI	ELECTRODE BRACKET	SUPPORT ELECTRODES	ELEKTRODEN HALTERUNG	CORCHETE DEL ELECTRODO		
*58	3000472	PROLUNGA	EXTENSION	RALLONGE	VERLÄNGERUNG	PROLUNGACIÓN		
59	3006714	BOBINA	COIL	BOBINE E.V.	MV-SPULE	BOBINA		B
60	3000611	GRUPPO SERRANDA	AIR DAMPER ASSEMBLY	GROUPE VOLET AIR	LUFTKLAPPE	REGISTRO AIRE		
61	3005492	GRUPPO VALVOLE	VALVE ASSEMBLY	GROUPE ELECTROVANNE	MAGNETVENTILBLOCK	CONJUNTO VÁLVULAS		B
62	3007132	ANELLO DE	DE RING	JOINT	DE RING	ANILLO DE		B
63	3007164	GUARNIZIONE	SEAL	RONDELLE	METALLDICHTUNG	JUNTA		B
64								
65								
66								
*67	3000570	DENTE	CONNECTION	JONCTION	STAURING	ANILLO LLAMA		
68	3009076	TUBO FLESSIBILE	FLEXIBLE OIL LINE	FLEXIBLE	SCHLAUCH	TUBO FLEXIBLE		A
69	3009068	RACCORDO	CONNECTOR	MAMELON	NIPPEL	RACORD		C
*70	3000571	CILINDRO	SLEEVE	CYLINDRE	ZYLINDER	CILINDRO		C

* = Versione Testa Lunga - Long Combustion Head Version - Version Tête Longue - Langer Brennkopf Ausführung - Versión alargado de tubo llama

**

A = Ricambi per dotazione minima - Spare parts for minimum fittings - Pièces détachées pour équipement minimum - Ersatzteile für minimale Ausstattung - Recambios para equipamiento mínimo

A+B = Ricambi per dotazione base di sicurezza - Spare parts for basic safety fittings - Pièces détachées pour équipement standard de sécurité - Ersatzteile für Sicherheitsgrundausrüstung - Recambios para equipamiento básico de seguridad

A+B+C = Ricambi per dotazione estesa di sicurezza - Spare parts for extended safety fittings - Pièces détachées pour équipement complet de sécurité - Ersatzteile für erweiterte Sicherheitsausstattung - Recambios para equipamiento general de seguridad

RIELLO

RIELLO S.p.A.
I-37045 Legnago (VR)
Tel.: +39.0442.630111
[http:// www.riello.it](http://www.riello.it)
[http:// www.rielloburners.com](http://www.rielloburners.com)