

- I** Bruciatori di gasolio
- GB** Light oil burners
- F** Brûleurs fioul domestiques
- D** Öl-Gebläsebrenner
- E** Quemadores de gasóleo

Funzionamento bistadio
Two-stage operation
Fonctionnement à deux allures
Zweistufiger Betrieb
Funcionamiento de dos llamas

CODICE - CODE CÓDIGO	MODELLO - MODEL - MODELE MODELL - MODELO	TIPO - TYPE - TYP
3476520	PRESS 4G	609 T1

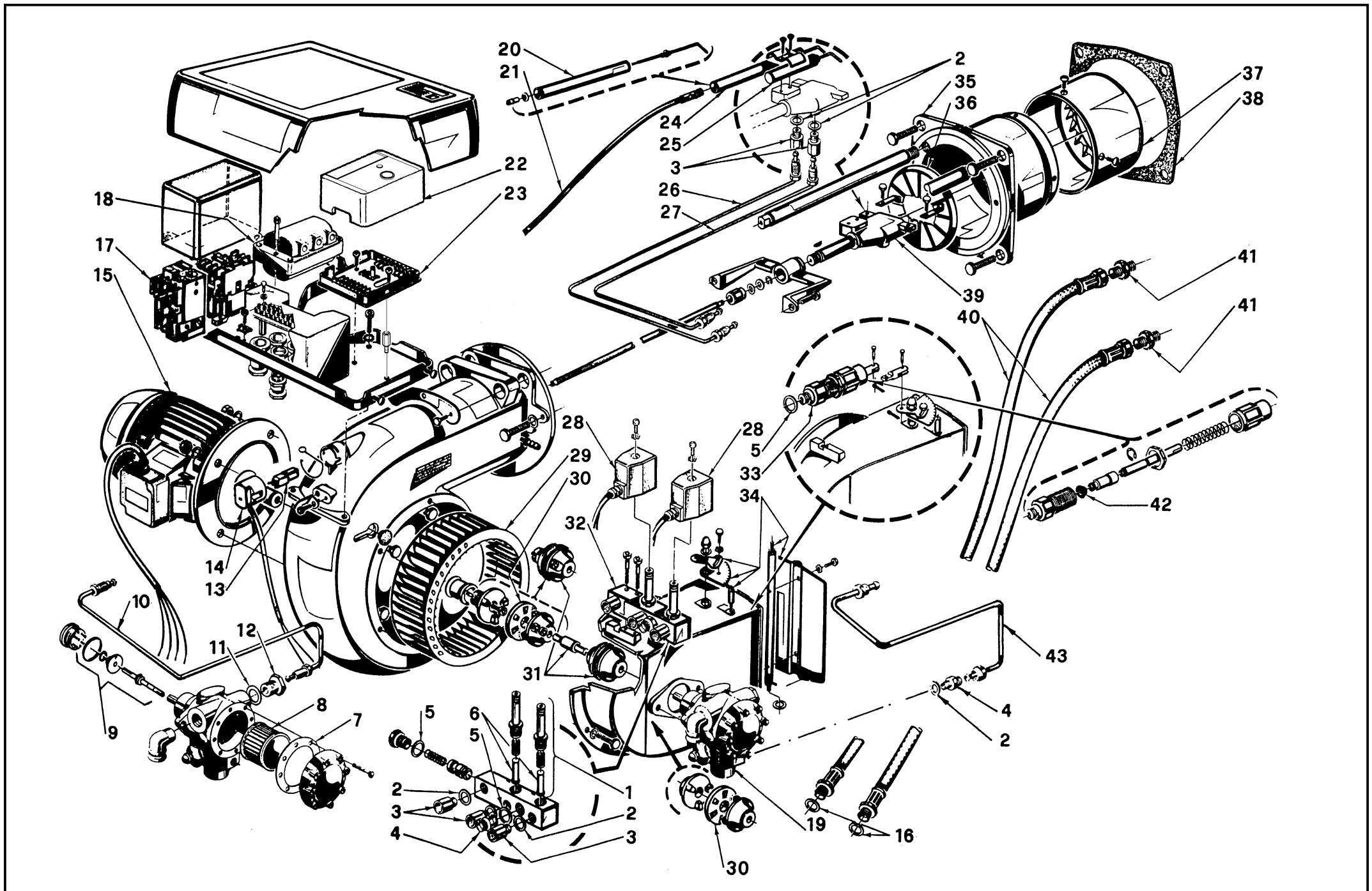

N.	COD.	DESCRIZIONE	DESCRIPTION	DESCRIPTION	BESCHREIBUNG	DENOMINACION	MATRICOLA BRUCIATORE BURNER SERIAL NUMBER MATRICULE BRULEUR BRENNER KENN-NUMMER MATRICULA QUEMADORES	RICAMBI CONSIGLIATI ADVISED PARTS RECHANGE CONSEIL EMPFOHLENE ERSATZTEILE RECAMBIOS A CONSEJADOS
								*
1	3005733	VALVOLA	NEEDLE VALVE	ROBINET POINTEAU	NADELVENTIL	VÁLVULA		
2	3007077	GUARNIZIONE	SEAL	RONDELLE	METALLDICHTUNG	JUNTA		B
3	3006719	RACCORDO	CONNECTOR	MAMELON	NIPPEL	RACORDO		C
4	3006723	RACCORDO	CONNECTOR	MAMELON	NIPPEL	RACORDO		C
5	3007079	GUARNIZIONE	SEAL	RONDELLE	METALLDICHTUNG	JUNTA		B
6	3006038	SPILLO	PIN	NOYAU ELECTROVANNE	KERN	CONTACTO		
7	3006292	GUARNIZIONE	SEAL	JOINT COUVERCLE POMPE	PUMPENDICHTUNG	JUNTA		A
8	3006787	FILTRO	FILTER	FILTRE	PUMPENFILTER	FILTRO		A
9	3000805	ORGANO DI TENUTA	PUMP SEAL	ORGANE D'ETANCHITE	WELLENDICHTUNG	CONNJUNTO ESTANQUIDAD		
10	3006752	TUBO	TUBE	TUYAUTERIE	DRUCKROHR	TUBO		
11	3007081	GUARNIZIONE	SEAL	RONDELLE	METALLDICHTUNG	JUNTA		B
12	3006786	RACCORDO	CONNECTOR	MAMELON	NIPPEL	RACORDO		C
13	3002280	FOTORESISTENZA	P.E. CELL	CELLULE	FOTOWIDERSTAND	FOTORESISTENCIA		A
14	3006441	PRESA	HOLDER	PRISE CELLULE	SOCKEL	CONECTOR		C
15	3008408	MOTORE	MOTOR	MOTEUR	MOTOR	MOTOR		C
16	3007164	GUARNIZIONE	SEAL	RONDELLE	METALLDICHTUNG	JUNTA		B
17	3012741	AVVIATORE	STARTER	DEMARREUR	ANLASSER	ARRANCADOR		C
18	3012159	TRASFORMATORE	TRANSFORMER	TRANSFORMATEUR	ZÜNDTRANSFORMATOR	TRANSFORMADOR		B
19	3006369	POMPA	PUMP	POMPE	PUMPE	BOMBA		C
20	3004843	ISOLATORE	INSULATOR	PORCELAINE D'ELECTRODE	ISOLATOR	AISLADOR		A
21	3012162	COLLEGAMENTO	H.T. LEAD	CABLE H.T.	ZÜNDKABEL	CABLE ALTA TENSION		A
22	3013071	APPARECCHIATURA	CONTROL BOX	BOITE DE CONTROLE	STEUERGERÄT	CAJA CONTROL		B
23	3003784	MORSETTIERA	CONTROL BOX BASE	SOCLE	STECKSOCKEL	ZOCALO CAJA CONTROL		C
24	3004842	ELETTRODO	ELECTRODE	ELECTRODE PORCELAINE	ELEKTRODE	ELECTRODO		A
25	3005490	ELETTRODO DI MASSA	EARTH ELECTRODE	ELECTRODE MASSE	MASSE ELEKTRODE	ELECTRODO DE TIERRA		A
26	3006754	TUBO	TUBE	TUYAUTERIE	DRUCKROHR	TUBO		
27	3006755	TUBO	TUBE	TUYAUTERIE	DRUCKROHR	TUBO		
28	3006714	BOBINA	COIL	BOBINE E.V.	MV - SPULE	BOBINA		B
29	3005508	GIRANTE	FAN	TURBINE	GEBLÄSERAD	TURBINA		C
30	3004821	DISCO ELASTICO	DISC	DISQUE	SCHEBE	DISCO ELÁSTICO		
31	3000736	GRUPPO GIUNZIONE	DRIVE COUPLING	ACCOUPEMENT	KUPPLUNG	ACOPLADOR IMPULSOR		A
32	3005492	GRUPPO VALVOLE	VALVE ASSEMBLY	GROUPE ELECTROVANNE	MAGNETVENTILBLOC	CONJUNTO VÁLVULAS		B
33	3005493	MARTINETTO	HYDRAULIC JACK	VERIN AIR	DRUCKKOLBEN FÜR LUFTKLAPPE	HIDRÁULICO		C
34	3000612	GRUPPO SERRANDA	AIR DAMPER ASSEMBLY	GROUPE VOLET AIR	LUFTKLAPPE	REGISTRO AIRE		
35	3005521	BOCCAGLIO	BLAST TUBE	GUEULARD	BRENNERFLANSCH	TUBO LLAMA		
36	3005507	ELICA	DIFFUSER DISC	ACCROCHE FLAMME	STAUSCHEIBE	DISCO ESTABILIZADOR		A
37	3005509	IMBUTO FIAMMA	END CONE	EMBOUT GUEULARD	FLAMMENROHR	TUBO LLAMA		B
38	3005744	SCHERMO	FLANGE GASKET	ECRAN THERMIQUE	FLANSCHDICHTUNG	JUNTA AISLANTE		A
39	3005520	PORTASPRUZZO	NOZZLE HOLDER	PULVERISATEUR	DÜSENSTOCK	PORTABOQUILLA		C
40	3009076	TUBO FLESSIBILE	FLEXIBLE OIL LINE	FLEXIBLE	SCHLAUCH	TUBO FLEXIBLE		A
41	3009068	RACCORDO	MAMELON	NIPPEL	NIPPEL	RACORDO		C
42	3007132	ANELLO DE	DE RING	JOINT	DE RING	ANILLO DE		B
43	3006753	TUBO	TUBE	TUYAUTERIE	DRUCKROHR	TUBO		

*

A = Ricambi per dotazione minima - Spare parts for minimum fittings - Pièces détachées pour équipement minimum - Ersatzteile für minimale Ausstattung - Recambios para equipamiento mínimo

A+B = Ricambi per dotazione base di sicurezza - Spare parts for basic safety fittings - Pièces détachées pour équipement standard de sécurité - Ersatzteile für Sicherheitsgrundausrüstung - Recambios para equipamiento básico de seguridad

A+B+C = Ricambi per dotazione estesa di sicurezza - Spare parts for extended safety fittings - Pièces détachées pour équipement complet de sécurité - Ersatzteile für erweiterte Sicherheitsausrüstung - Recambios para equipamiento general de seguridad

RIELLO

RIELLO S.p.A.
I-37045 Legnago (VR)
Tel.: +39.0442.630111
[http:// www.riello.it](http://www.riello.it)
[http:// www.rielloburners.com](http://www.rielloburners.com)