

- I** Bruciatori di gasolio
- GB** Light oil burners
- F** Brûleurs fioul domestique
- D** Öl-Gebläsebrenner
- E** Quemadores de gasóleo

Funzionamento bistadio progressivo o modulante
Two stage progressive or modulating operation
Fonctionnement à 2 allures progressif ou modulant
Zweistufig-gleitender oder modulierender Betrieb
Funcionamiento a 2 llamas progresivas o modulante

CODICE - CODE CÓDIGO	MODELLO - MODEL - MODELE MODELL - MODELO	TIPO - TYPE - TYP
3477810 - 3477811	RL 190/M	674 T1
20011021 - 20011022	RL 190/M	674 T1
20052628	RL 190/M TL	674 T1

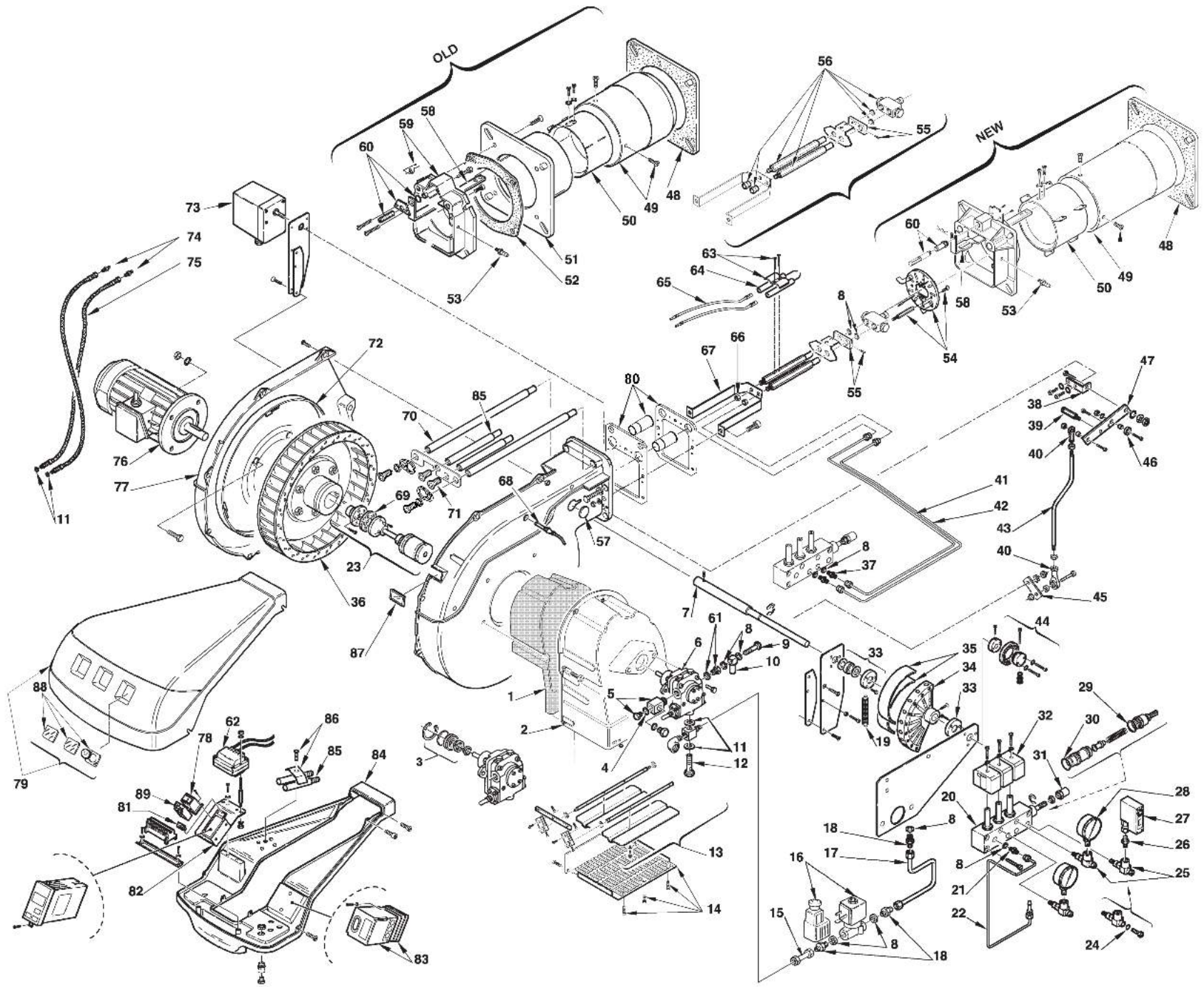

N.	COD.	3477810 - 3477811 20011021 - 20011022 20052628	DESCRIZIONE	DESCRIPTION	DESCRIPTION	BESCHREIBUNG	DENOMINACION	MATRICOLA BRUCIATORE BURNER SERIAL NUMBER MATRICULE BRULEUR BRENNER KENN-NUMMER MATRICULA QUEMADÓRES	*
1	3012553	•	FONOASSORBENTE	SOUND DAMPING	INSONORISANT	GERÄUSCHDÄMMUNG	AISLAMIENTO ACÚSTICO	≤ 02406xxxxxx	
1	3013682	•	FONOASSORBENTE	SOUND DAMPING	INSONORISANT	GERÄUSCHDÄMMUNG	AISLAMIENTO ACÚSTICO	≥ 02416xxxxxx	
1	3013682	•	FONOASSORBENTE	SOUND DAMPING	INSONORISANT	GERÄUSCHDÄMMUNG	AISLAMIENTO ACÚSTICO		
1	3013682	•	FONOASSORBENTE	SOUND DAMPING	INSONORISANT	GERÄUSCHDÄMMUNG	AISLAMIENTO ACÚSTICO		
2	3012828	•	BOCCA D'ASPIRAZIONE	AIR INTAKE	BOITIER D'ASPIRATION	ANSAUGÖFFNUNG	BOCA ASPIRACION	≤ 02406xxxxxx	
3	3000804	•••	ORGANO DI TENUTA	PUMP SEAL	ORGANE D'ETANCHEITE	WELLENDICHTUNG	CONJUNTO ESTANQUIDAD		
4	3007077	•••	GUARNIZIONE	SEAL	RONDELLE	METALLDICHTUNG	JUNTA		A
5	3003681	•••	RACCORDO	CONNECTOR	MAMELON	NIPPEL	RACORD		
6	3006158	•••	POMPA	PUMP	POMPE	PUMPE	BOMBA		A
7	3012829	•••	ALBERO	SHAFT	ARBRE	WELLE	ARBORILLO		
8	3007079	•••	GUARNIZIONE	SEAL	RONDELLE	METALLDICHTUNG	JUNTA		A
9	3003006	•••	RACCORDO	CONNECTOR	MAMELON	NIPPEL	RACORD		
10	3012455	•••	RACCORDO	CONNECTOR	MAMELON	NIPPEL	RACORD		
11	3007164	•••	GUARNIZIONE	SEAL	RONDELLE	METALLDICHTUNG	JUNTA		A
12	3006184	•••	PERNO	BAR	GLISSIERE	BOLZEN	PERNO		C
13	3012583	•	GRUPPO SERRANDA	AIR DAMPER ASSEMBLY	GROUPE VOLET AIR	LUFTKLAPPE	REGISTRO AIRE	≤ 02406xxxxxx	
13	3013860	•	GRUPPO SERRANDA	AIR DAMPER ASSEMBLY	GROUPE VOLET AIR	LUFTKLAPPE	REGISTRO AIRE	≥ 02416xxxxxx	
13	3013860	•	GRUPPO SERRANDA	AIR DAMPER ASSEMBLY	GROUPE VOLET AIR	LUFTKLAPPE	REGISTRO AIRE		
13	3013860	•	GRUPPO SERRANDA	AIR DAMPER ASSEMBLY	GROUPE VOLET AIR	LUFTKLAPPE	REGISTRO AIRE		
14	3003086	•	PROTEZIONE	GRID	PROTECTION	SCHUTZGITTER	PROTECCIÓN	≤ 02406xxxxxx	
14	3013683	•	PROTEZIONE	GRID	PROTECTION	SCHUTZGITTER	PROTECCIÓN	≥ 02416xxxxxx	
14	3013683	•	PROTEZIONE	GRID	PROTECTION	SCHUTZGITTER	PROTECCIÓN		
14	3013683	•	PROTEZIONE	GRID	PROTECTION	SCHUTZGITTER	PROTECCIÓN		
15	3012457	•••	TUBO	TUBE	TUYAUTERIE	DRUCKROHR	TUBO		
16	3012165	•••	ELETTROVALVOLA	SOLENOID VALVE	ELECTRO - VANNE	MAGNET VENTIL	ELECTROVÁLVULA		B
17	3012830	•••	TUBO	TUBE	TUYAUTERIE	DRUCKROHR	TUBO		
18	3009081	•••	RACCORDO	CONNECTOR	MAMELON	NIPPEL	RACORD		
19	3012356	•••	MOLLA	FLAT SPRING	RESSORT PLAT	KURVENBAND	MUELLE		A
20	3012474	•••	MODULATORE	MODULATOR	MODULATEUR	MODULATOR	MODULADOR		B
21	3006723	•••	RACCORDO	CONNECTOR	MAMELON	NIPPEL	RACORD		
22	3012831	•••	TUBO	TUBE	TUYAUTERIE	DRUCKROHR	TUBO		

N.	COD.	3477810 - 3477811 20011021 - 20011022 20052628	DESCRIZIONE	DESCRIPTION	DESCRIPTION	BESCHREIBUNG	DENOMINACION	MATRICOLA BRUCIATORE BURNER SERIAL NUMBER MATRICULE BRULEUR BRENNER KENN-NUMMER MATRICULA QUEMADORES	*
23	3012832	• • •	GRUPPO GIUNZIONE	DRIVE COUPLING	ACCOUPEMENT	KUPPLUNG	GRUPO CONJUNTO		A
24	3007169	• • •	ANELLO OR	O RING	JOINT TORIQUE	O RING	JUNTA TÓRICA		A
25	3012476	• • •	VALVOLA DI SCARICO	NEEDLE VALVE	ROBINET POINTEAU	NADELVENTIL	VALVULA DE ESCAPE		B
26	3009080	• • •	RACCORDO	CONNECTOR	MAMELON	NIPPEL	RACORD		
27	3012384	• • •	PRESSOSTATO OLIO	PRESSURE SWITCH	PRESSOSTAT	PRESSOSTAT	PRESOSTATO OLIO		B
28	3006140	• • •	MANOMETRO	PRESSURE GAUGE	MANOMETRE	MANOMETER	MANOMETRO		A
29	3003204	• • •	GUARNIZIONE	SEAL	RONDELLE	METALLDICHTUNG	JUNTA		A
30	3007150	• • •	ANELLO OR	O RING	JOINT TORIQUE	O RING	JUNTA TÓRICA		A
31	3003200	• • •	DADO	NUT	ECROU BORGNE	MUTTER	TUERCA		
32	3003001	• • •	BOBINA	COIL	BOBINE E.V.	MV-SPULE	BOBINA		B
33	3012357	• • •	CUSCINETTO	BEARING	ROULEMENT	LAGER	COJINETE		
34	3012358	• • •	CAMMA	CAM	CAME	VERBUNDREGLER	EXENTRICO		C
35	3006097	• • •	MOLLA	FLAT SPRING	RESSORT PLAT	KURVENBAND	MUELLE		A
36	3012555	• • •	GIRANTE	FAN	TURBINE	GEBLÄSERAD	TURBINA		C
37	3003005	• • •	RACCORDO	CONNECTOR	MAMELON	NIPPEL	RACORD		
38	3012602	• • •	SUPPORTO	SUPPORT	SUPPORT	HALTER	SOPORTE		
39	3012352	• • •	PERNO	SCREW	VIS CREUSE	HOHLKERNSCHRAUBE	PERNO		C
40	3006098	• • •	SNODO SFERICO	PIN JOINT	CHAPE A ROTULE	KUGELGELENK	ARTICOLACION ENSFERICO		C
41	3012833	•	TUBO	TUBE	TUYAUTERIE	DRUCKROHR	TUBO	≤ 02406xxxxxx	
41	3013867	•	TUBO	TUBE	TUYAUTERIE	DRUCKROHR	TUBO	≥ 02416xxxxxx	
41	3013867	•	TUBO	TUBE	TUYAUTERIE	DRUCKROHR	TUBO		
41	3013867	•	TUBO	TUBE	TUYAUTERIE	DRUCKROHR	TUBO		
42	3012834	•	TUBO	TUBE	TUYAUTERIE	DRUCKROHR	TUBO	≤ 02406xxxxxx	
42	3013868	•	TUBO	TUBE	TUYAUTERIE	DRUCKROHR	TUBO	≥ 02416xxxxxx	
42	3013868	•	TUBO	TUBE	TUYAUTERIE	DRUCKROHR	TUBO		
42	3013868	•	TUBO	TUBE	TUYAUTERIE	DRUCKROHR	TUBO		
43	3012646	• • •	TIRANTE	TIE ROD	TIRANT	GESTÄNGE	TIRANTE		
44	3012472	• • •	CUSCINETTO	BEARING	ROULEMENT	LAGER	COJINETE		
45	3012601	• • •	LEVA	LEVER	LEVIER	HEBEL	PALANCA		
46	3003841	• • •	CUSCINETTO	BEARING	ROULEMENT	LAGER	COJINETE		
47	3012354	• • •	LEVA	LEVER	LEVIER	HEBEL	PALANCA		

N.	COD.	3477810 - 3477811 20011021 - 20011022 20052628	DESCRIZIONE	DESCRIPTION	DESCRIPTION	BESCHREIBUNG	DENOMINACION	MATRICOLA BRUCIATORE BURNER SERIAL NUMBER MATRICULE BRULEUR BRENNER KENN-NUMMER MATRICULA QUEMADÓRES	*
48	3012562	• • •	SCHERMO	FLANGE GASKET	ECRAN THERMIQUE	FLANSCHDICHTUNG	JUNTA AISLANTA		A
49	3012561	•	IMBUTO FIAMMA	END CONE	EMBOUT GUEULARD	FLAMMENROHR	TUBO EXTREMO	≤ 02406xxxxxx	B
49	3013760	•	IMBUTO FIAMMA	END CONE	EMBOUT GUEULARD	FLAMMENROHR	TUBO EXTREMO	≥ 02416xxxxxx	B
49	20054544	•	IMBUTO FIAMMA	END CONE	EMBOUT GUEULARD	FLAMMENROHR	TUBO EXTREMO		B
49	3013760	•	IMBUTO FIAMMA	END CONE	EMBOUT GUEULARD	FLAMMENROHR	TUBO EXTREMO		B
50	3012560	• • •	OTTURATORE	SHUTTER	OBTURATEUR	SCHIEBER	OBTURADOR		C
51	3012576	•	BOCCAGLIO	BLAST TUBE	GUEULARD	BRENNERFLANSCH	TUBO LLAMA	≤ 02406xxxxxx	C
52	3012572	•	SCHERMO	FLANGE GASKET	ECRAN THERMIQUE	FLANSCHDICHTUNG	JUNTA AISLANTA	≤ 02406xxxxxx	A
53	3003322	•	RACCORDO	CONNECTOR	MAMELON	NIPPEL	RACORD	≤ 02406xxxxxx	
54	3012835	• • •	ELICA	DIFFUSER DISC	ACCROCHE FLAMME	STAUSCHEIBE	DISCO ESTABILIZADOR		A
55	3003790	• • •	PIASTRA	ANCHOR PLATE	PLATINE DE BLOCAGE	ARRETIERPLATTE	PLACA		
56	3012096	• • •	GRUPPO PORTAUGELLO	NOZZLE HOLDER	GROUPE PORTE-GICLEUR	DÜSENSTOCK	GRUPO PORTABOQUILLA		C
57	3003996	• • •	TAPPO	PLUG	BOUCHON A VIS	SCHRAUBSTÖPSEL	TAPON		
58	3003982	•	SQUADRETTA	SQUARE	EQUERRE-SUPPORT	HALTER	ESCUADRA	≤ 02406xxxxxx	
58	3013698	•	SQUADRETTA	SQUARE	EQUERRE-SUPPORT	HALTER	ESCUADRA	≥ 02416xxxxxx	
58	3013703	•	SQUADRETTA	SQUARE	EQUERRE-SUPPORT	HALTER	ESCUADRA		
58	3013698	•	SQUADRETTA	SQUARE	EQUERRE-SUPPORT	HALTER	ESCUADRA		
59	3012836	•	FRONTONE	FRONT PIECE	FACADE	VORDERTEIL	SOPORTE	≤ 02382000584	
59	3012911	•	FRONTONE	FRONT PIECE	FACADE	VORDERTEIL	SOPORTE	≥ 02382000585; ≤ 02406xxxxxx	
60	3003974	•	GRUPPO REGOLATORE	CONTROL DEVICE	GROUPE OBTURATION	DRUCKREGULIERUNG	GRUPO REGULACION	≤ 02406xxxxxx	
60	3012639	•	GRUPPO REGOLATORE	CONTROL DEVICE	GROUPE OBTURATION	DRUCKREGULIERUNG	GRUPO REGULACION	≥ 02416xxxxxx	
60	3012639	• •	GRUPPO REGOLATORE	CONTROL DEVICE	GROUPE OBTURATION	DRUCKREGULIERUNG	GRUPO REGULACION		
61	3006423	• • •	RACCORDO	CONNECTOR	MAMELON	NIPPEL	RACORD		
62	3012488	• • •	TRASFORMATORE	TRANSFORMER	TRANSFORMATEUR	ZÜNDTRANSFORMATOR	TRANSFPRMADOR		B
63	3003495	• • •	CAVALLOTTO	U BOLT	CAVALIER	BÜGELBOLZEN	FIJACION ELECTRODO		
64	3003796	• • •	ELETTRODO	ELECTRODE	ELECTRODE PORCELAINE	ELEKTRODE	ELECTRODO		A
65	3003973	• •	COLLEGAMENTO ELET- TRODO	ELECTRODE CONNECTION	CONNEXION ELECTRODE	ELEKTRODEVERBINDUNG	CONEXIÓN ELECTRODO		A
65	3012162	•	COLLEGAMENTO ELET- TRODO	ELECTRODE CONNECTION	CONNEXION ELECTRODE	ELEKTRODEVERBINDUNG	CONEXIÓN ELECTRODO		A
66	3012095	• • •	DADO	NUT	ECROU BORGNE	MUTTER	TUERCA		
67	3012461	• • •	SUPPORTO	SUPPORT	SUPPORT	HALTER	SOPORTE		

N.	COD.	3477810 - 3477811 20011021 - 20011022 20052628	DESCRIZIONE	DESCRIPTION	DESCRIPTION	BESCHREIBUNG	DENOMINACION	MATRICOLA BRUCIATORE BURNER SERIAL NUMBER MATRICULE BRULEUR BRENNER KENN-NUMMER MATRICULA QUEMADORES	*
68	3012091	• • •	FOTORESISTENZA	P.E. CELL	CELLULE	FOTOWIDERSTAND	FOTORESISTENCIA		A
69	3004821	• • •	DISCO ELASTICO	DRIVE DISK	DISQUE ELASTIQUE	KUPPLUNGSSCHEIBE	DISCO ELASTICO		
70	3003970	• • •	PERNO	SCREW	VIS CREUSE	HOHLKERNSCHRAUBE	PERNO	≤ 02406xxxxxx	C
71	3003481	• • •	VITE	SCREW	VIS	SCHRAUBE	TORNILLO	≤ 02406xxxxxx	
71	3013681	• • •	VITE	SCREW	VIS	SCHRAUBE	TORNILLO	≥ 02416xxxxxx	
71	3013681	• • •	VITE	SCREW	VIS	SCHRAUBE	TORNILLO		
71	3013681	• • •	VITE	SCREW	VIS	SCHRAUBE	TORNILLO		
72	3012573	• • •	ANELLO	RING	ANNEAU	RING	ANILLO		
73	3012345	• • •	SERVOMOTORE	SERVOMOTOR	SERVOMOTEUR	STELLMOTOR	SERVOMOTOR		B
74	3006181	• • •	RACCORDO	CONNECTOR	MAMELON	NIPPEL	RACORD		
75	3006182	• • •	TUBO FLESSIBILE	FLEXIBLE OIL LINE	FLEXIBLE	SCHLAUCH	TUBO FLEXIBILE		A
76	20050960	• • •	MOTORE	MOTOR	MOTEUR	MOTOR	MOTOR		C
77	3012587	• • •	GUSCIO	HALF-SHELL	COUVERCLE	HAUBE	CÁSCARA		
78	3012556	• • •	RELE' TERMICO + CONTATTORE	OVERLOAD + CONTACTOR	RELAIS THERMIQUE + CONTACTE.	ÜBERSTROMAUSLÖSER + SCHÜTZ	CONECTADOR+CONTADOR	≤ 02179xxxxxx	C
78	3013978	• • •	CONTATTORE	CONTACTOR	CONTACTE.	SCHÜTZ	CONTADOR	≥ 02189xxxxxx	C
78	3013978	• • •	CONTATTORE	CONTACTOR	CONTACTE.	SCHÜTZ	CONTADOR		C
78	3013978	• • •	CONTATTORE	CONTACTOR	CONTACTE.	SCHÜTZ	CONTADOR		C
79	3013119	• • •	COFANO	COVER	COFFRET	VERKLEIDUNG	ENVOLVENTE		
80	3013685	• • •	GRUPPO PIASTRE	PLATES ASSEMBLY	GROUPE PLATINES	PLATTEN GROUPE	CONJUNTO PLACAS	≥ 02416xxxxxx	
80	20057639	• • •	GRUPPO PIASTRE	PLATES ASSEMBLY	GROUPE PLATINES	PLATTEN GROUPE	CONJUNTO PLACAS		
81	3012080	• • •	INTERRUTTORE	SWITCH	INTERRUPTEUR	SCHALTER	INTERUCTOR		C
82	3012748	• • •	SUPPORTO	SUPPORT	SUPPORT	HALTER	SOPORTE	≤ 02179xxxxxx	
83	3006215	• • •	APPARECCHIATURA	CONTROL BOX	BOÎTE DE CONTRÔLE	STEUERGERÄT	CAJA DE CONTROL		B
84	3012459	• • •	MENSOLA	BASE PLATE	PLAQUE DE SUPPORT	GRUNDPLATTE	REPISA		
85	3003956	• • •	PROLUNGA PERNO	BAR EXTENSION	RALLONGE DE GLISSIERE	VERLÄNGERUNG	EXTENSION PERNO	≤ 02406xxxxxx	
85	3013687	• • •	PROLUNGA PERNO	BAR EXTENSION	RALLONGE DE GLISSIERE	VERLÄNGERUNG	EXTENSION PERNO	≥ 02416xxxxxx	
85	3013686	• • •	PROLUNGA PERNO	BAR EXTENSION	RALLONGE DE GLISSIERE	VERLÄNGERUNG	EXTENSION PERNO		
85	3013687	• • •	PROLUNGA PERNO	BAR EXTENSION	RALLONGE DE GLISSIERE	VERLÄNGERUNG	EXTENSION PERNO		
86	3003409	• • •	CAVALLOTTO	U BOLT	CAVALIER	BÜGELBOLZEN	FIJACION ELECTRODO	≤ 02406xxxxxx	
87	3003763	• • •	VISORE	INSPECTION WINDOW	WISEUR	SICHTFENSTER	VISOR		

N.	COD.	3477810 - 3477811 20011021 - 20011022 20052628	DESCRIZIONE	DESCRIPTION	DESCRIPTION	BESCHREIBUNG	DENOMINACION	MATRICOLA BRUCIATORE BURNER SERIAL NUMBER MATRICULE BRULEUR BRENNER KENN-NUMMER MATRICULA QUEMADÓRES	*
88	3013678	• • •	MEMBRANA + VETRINO	MEMBRANE+VIEWING PORT	MEMBRANE+REGARD	MEMBRAN+VER- SCHLUßSTOPFEN	MEMBRANA+MIRILLA		
89	3013980	•	RELÈ TERMICO	OVERLOAD	RELAIS THERMIQUE	ÜBERSTROMAUSLÖSER	RELÈ TERMICO	≥ 02189xxxxxx	C
89	3013980	•	RELÈ TERMICO	OVERLOAD	RELAIS THERMIQUE	ÜBERSTROMAUSLÖSER	RELÈ TERMICO		C
89	3013676	•	RELÈ TERMICO	OVERLOAD	RELAIS THERMIQUE	ÜBERSTROMAUSLÖSER	RELÈ TERMICO		C

*

RICAMBI CONSIGLIATI - ADVISED PARTS - RECHANGE CONSEIL - EMPFOHLENE ERSATZTEILE - RECAMBIOS ACONSEJADOS

A = Ricambi per dotazione minima - Spare parts for minimum fittings - Pièces détachées pour équipement minimum - Ersatzteile für minimale Ausstattung - Recambios para equipamiento mínimo

A+B = Ricambi per dotazione base di sicurezza - Spare parts for basic safety fittings - Pièces détachées pour équipement standard de sécurité - Ersatzteile für Sicherheitsgrundausrüstung - Recambios para equipamiento básico de seguridad

A+B+C = Ricambi per dotazione estesa di sicurezza - Spare parts for extended safety fittings - Pièces détachées pour équipement complet de sécurité - Ersatzteile für erweiterte Sicherheitsausstattung - Recambios para equipamiento general de seguridad

RIELLO

RIELLO S.p.A.
I-37045 Legnago (VR)
Tel.: +39.0442.630111
[http:// www.riello.it](http://www.riello.it)
[http:// www.rielloburners.com](http://www.rielloburners.com)