

ENNE/EMME SERIES

The ENNE/EMME 1400–4500 series of burners covers a firing range from 814 to 5000 kW.

They have been designed for high output users and they are suitable for matching with every kind of boilers, with normal or pressurized combustion chamber.

Operation can be “two stage progressive” or, alternatively, “modulating” with the installation of a PID logic regulator and respective probes. Two fuel options are available: only gas and only heavy oil, thus settable by a manual switch. Heavy oil circuit is fitted with his own electric motor: this permits pump stop during gas operation preventing danger of pumping seizure and avoiding oil circulation. A wide range of accessories and gas trains suitable to the burners guarantee an elevated working flexibility.



ENNE/EMME 1400	407/814 ÷ 1628 kW
ENNE/EMME 2000	581/1163 ÷ 2325 kW
ENNE/EMME 3000	872/1744 ÷ 3488 kW
ENNE/EMME 4500	1163/2325 ÷ 5000 kW

FIRING RATES

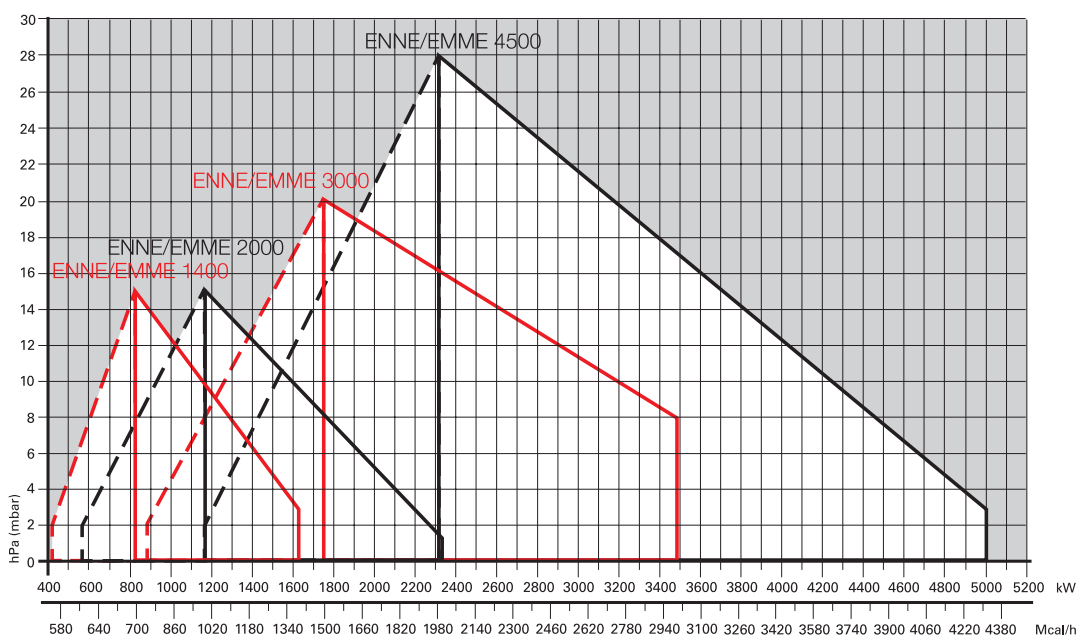

 Useful working field for choosing the burner

 Modulation range

Test conditions conforming to EN267- EN676
 Temperature: 20°C
 Pressure: 1013,5 mbar
 Altitude: 0 m a.s.l.

Modulating Dual Fuel Burners

ENNE/EMME SERIES

Overall dimensions (mm)

BURNER

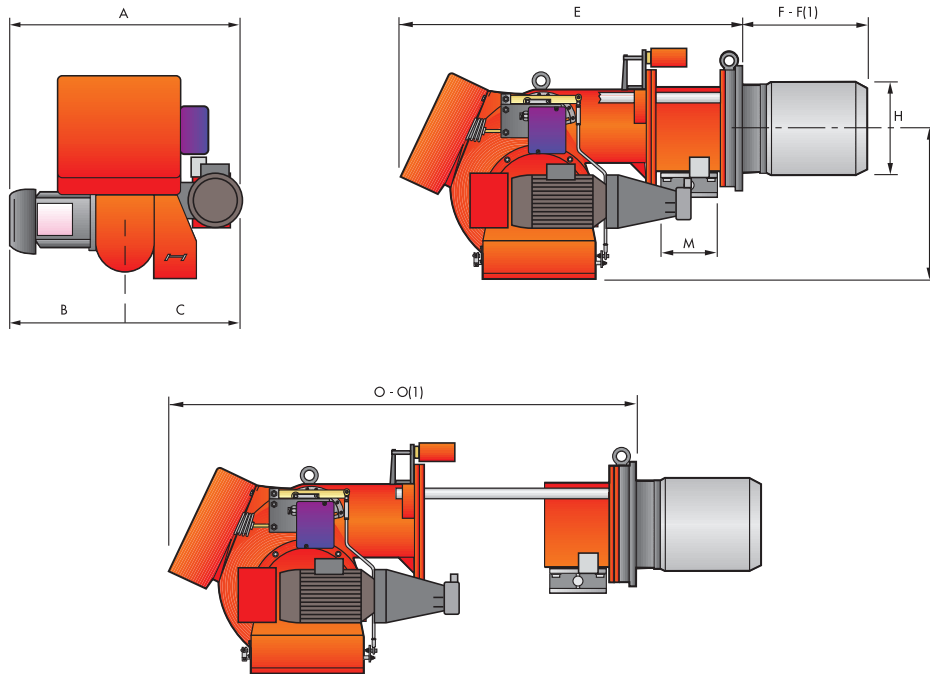

MODEL	A	B	C	E	F - F(1)	H	I	M	O - O(1)
▶ ENNE/EMME 1400	892	376	516	1090	385 - 495	250	467	2"	1475 - 1585
▶ ENNE/EMME 2000	912	396	516	1090	385 - 495	260	467	DN80	1475 - 1585
▶ ENNE/EMME 3000	1000	447	553	1320	476 - 606	336	525	DN80	1796 - 1926
▶ ENNE/EMME 4500	1061	508	553	1320	476 - 606	336	525	DN80	1796 - 1926

(1) Length with extended combustion head

BURNER - BOILER MOUNTING FLANGE

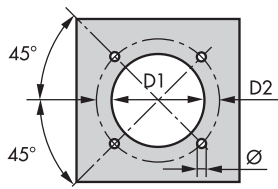

MODEL	D1	D2	Ø
▶ ENNE/EMME 1400	255	368	M16
▶ ENNE/EMME 2000	265	368	M16
▶ ENNE/EMME 3000	340	438	M20
▶ ENNE/EMME 4500	340	438	M20

PACKAGING

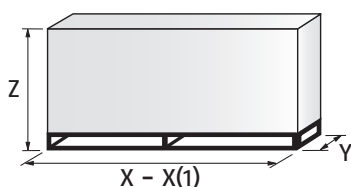

MODEL	X - X(1)	Y	Z	Kg
▶ ENNE/EMME 1400	1740 - 1740	990	950	265
▶ ENNE/EMME 2000	1740 - 1740	990	950	265
▶ ENNE/EMME 3000	2040 - 2040	1180	1125	280
▶ ENNE/EMME 4500	2040 - 2040	1180	1125	500

(1) Length with extended combustion head

Specification

DESIGNATION OF SERIES

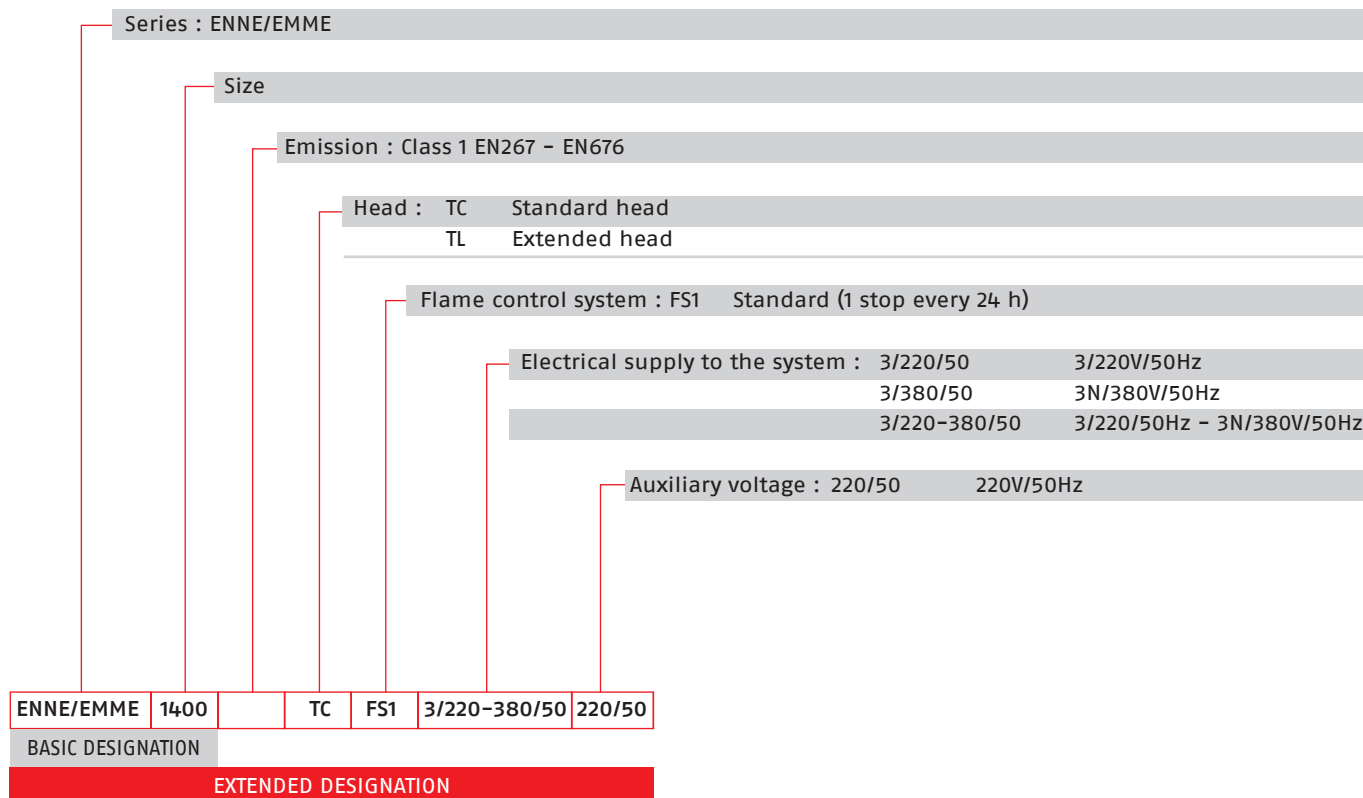

Modulating Dual Fuel Burners

ENNE/EMME SERIES

Specification

STATE OF SUPPLY

Monoblock forced draught dual fuel burner, two stage progressive or modulating operation with a kit, made up of:

- Air suction circuit
- Fan with forward curved blades
- Air damper for setting and butterfly valve for regulating fuel output controlled by a servomotor
- Combustion head, that can be set on the basis of required output
- Maximum gas pressure switch
- Minimum air pressure switch
- Fan electrical motor
- Dedicated 1400 rpm low speed pump motor
- Gears pump for high pressure fuel supply, fitted with:
 - filter
 - pressure regulator
 - connections for installing a pressure gauge and a a vacuumeter
 - internal by-pass for single pipe installation
- Preheater unit
- Valve unit with a double oil safety valve on the output circuit and safety valve on the return circuit
- Heavy oil heating cartridges factory installed on pump and valves group
- UV photocell for flame detection
- Flame inspection window
- Slide bars for easier installation and maintenance
- Protection filter against radio interference
- IP X0D (IP 40) protection level.

Standard equipment:

- 1 gas train flange
- 12 screws for fixing the burner flange to the boiler
- 1 insulating screen
- 2 flexible hoses for connection to the oil supply circuit
- 2 nipples for connection to the pump
- 4 wiring looms fittings for electrical connections
- 2 pin extensions
- 8 washers
- Instruction handbook for installation, use and maintenance
- Spare parts catalogue.

ENNE/EMME SERIES

Available models

Burners

CODE	MODEL	HEAT OUTPUT			TOTAL ELECTRICAL POWER (kW)	CERTIFICATION	NOTE
		(kW)	LIGHT OIL (kg/h)	NATURAL GAS (Nm ³ /h)			
3486701	ENNE/EMME 1400 TC FS1 3/230-400/50 230/50	407/814-1628	35/70-140	41/81-163	6,5 (oil) 5,2 (gas)		
3486702	ENNE/EMME 1400 TL FS1 3/230-400/50 230/50	407/814-1628	35/70-140	41/81-163	6,5 (oil) 5,2 (gas)		
3487801	ENNE/EMME 2000 TC FS1 3/230-400/50 230/50	581/1163-2325	50/100-200	58/116-233	6,6 (oil) 5,3 (gas)		
3487802	ENNE/EMME 2000 TL FS1 3/230-400/50 230/50	581/1163-2325	50/100-200	58/116-233	6,6 (oil) 5,3 (gas)		
3488801	ENNE/EMME 3000 TC FS1 3/230-400/50 230/50	872/1744-3488	75/150-300	87/174-349	10,6 (oil) 12,4 (gas)		
3488802	ENNE/EMME 3000 TL FS1 3/230-400/50 230/50	872/1744-3488	75/150-300	87/174-349	6,5 (oil) 5,2 (gas)		
3489201	ENNE/EMME 4500 TC FS1 3/230/50 230/50	1163/2325-5000	100/200-430	116/233-500	18,7 (oil) 16,9 (gas)		(1)
3489202	ENNE/EMME 4500 TL FS1 3/230/50 230/50	1163/2325-5000	100/200-430	116/233-500	18,7 (oil) 16,9 (gas)		(1)
3489203	ENNE/EMME 4500 TC FS1 3/400/50 230/50	1163/2325-5000	100/200-430	116/233-500	18,7 (oil) 16,9 (gas)		(1)
3489204	ENNE/EMME 4500 TL FS1 3/400/50 230/50	1163/2325-5000	100/200-430	116/233-500	18,7 (oil) 16,9 (gas)		(1)

(1) Star delta starter.

Net calorific value light oil: 11,8 kWh/kg; 10.200 kcal/kg - Viscosity up to 20°E (150 mm²/s, cSt), Type BUNKER B / USA n° 5 (with separate 1400 rpm low speed pump, heavy oil heating cartridges factory installed on pump and valves group).

Net calorific value G20 gas: 10 kWh/Nm³; 8.600 kcal/Nm³ - Density: 0,71 kg/Nm³.

The burners of ENNE/EMME series are in according to 90/396 - 2004/108 - 2006/95 EC Directive and EN 267-676 Norm.

Modulating Dual Fuel Burners

ENNE/EMME SERIES

Available models

Gas Trains

CODE	GAS TRAIN			VPS CODE	ADAPTER CODE			
	MODEL	Ø	C.T.		N/M 1400	N/M 2000	N/M 3000	N/M 4500
3970256*	MB 412/1 - RT 52	Rp 1" ¼	-	3010123	3010126	●	●	●
3970144*	MB 412/1 - RT 20	Rp 1" ¼	-	3010123		●	●	●
3970197**	MB 412/1 CT RT 20	Rp 1" ¼	◆	-		●	●	●
3970231*	MB 412/1 - RSM 20	Rp 1" ¼	-	3010123		●	●	●
3970180*	MB 415/1 - RT 30	Rp 1" ½	-	3010123	3000843	20064220 + 3010128		●
3970198**	MB 415/1 CT RT 30	Rp 1" ½	◆	-				●
3970250*	MB 415/1 - RT 52	Rp 1" ½	-	3010123				●
3970253**	MB 415/1 CT RT 52	Rp 1" ½	◆	-				●
3970232*	MB 415/1 - RSM 30	Rp 1" ½	-	3010123	-			●
3970181*	MB 420/1 - RT 30	Rp 2"	-	3010123				●
3970182**	MB 420/1 CT RT 30	Rp 2"	◆	-				●
3970257*	MB 420/1 - RT 52	Rp 2"	-	3010123				●
3970252**	MB 420/1 CT RT 52	Rp 2"	◆	-	-	20042324 + 3010128		●
3970233*	MB 420/1 - RSM 30	Rp 2"	-	3010123				●
3970234**	MB 420/1 CT RSM 30	Rp 2"	◆	-				●
3970221*	MBC 1200/1 - RSM 60	Rp 2"	-	3010367				●
3970225**	MBC 1200/1 CT RSM 60	Rp 2"	◆	-	-	20042324 + 3010128		
3970222*	MBC 1900/1 - FSM 40	DN 65	-	3010367				
3970226**	MBC 1900/1 CT FSM 40	DN 65	◆	-	3000825	3000831		
3970223*	MBC 3100/1 - FSM 40	DN 80	-	3010367	3000826	3000832		
3970227**	MBC 3100/1 CT FSM 40	DN 80	◆	-				
3970224*	MBC 5000/1 - FSM 80	DN 100	-	3010367	●	●	3010127	
3970228**	MBC 5000/1 CT FSM 80	DN 100	◆	-	●			
3970145*	CB 512/1 - RSM 30	Rp 1" ½	-	3010367	3000843	20064220 + 3010128		●
20045589**	CB 512/1 CT RSM 30	Rp 1" ½	◆	-				●
3970146*	CB 520/1 - RSM 30	Rp 2"	-	3010367	-	20042324 + 3010128		
3970160**	CB 520/1 CT RSM 30	Rp 2"	◆	-				
20044659*	CB 525/1 - RSM 30	Rp 2"	-	3010367				
20044660**	CB 525/1 CT RSM 30	Rp 2"	◆	-				
3970147*	CB 5065/1 - FSM 30	DN 65	-	3010367	3000825	3000831		
3970161**	CB 5065/1 CT FSM 30	DN 65	◆	-				
3970148*	CB 5080/1 - FSM 30	DN 80	-	3010367	3000826	3000832		
3970162**	CB 5080/1 CT FSM 30	DN 80	◆	-				
3970149*	CB 50100/1 - FSM 30	DN 100	-	3010367	3010370 +	3010127		
3970163**	CB 50100/1 CT FSM 30	DN 100	◆	-	3000826			
20015871*	CB 50125/1 - FSM 30	DN 125	-	3010367	3010224 +	3090940		
3970196**	CB 50125/1 CT FSM 30	DN 125	◆	-	3000826			

Please see designation of Gas Train Series in the page before the Catalogue index.

* 230V/50Hz -220V/60Hz electrical supply.

** 230V/50Hz electrical supply.

The valve seal control device is compulsory (conforming to EN 676) on gas trains to burners with a maximum output over 1200 kW.

To select the gas train please refer to the technical data leaflet and/or instruction manual.

C.T. Gas valve leak detection control device:

- gas train not equipped with leak detection control device; this device can be ordered separately - see VPS column - and installed later.
- ◆ gas train equipped with leak detection control device.

VPS Valve leak detection control device. Supplied separately from the gas train (please see Gas train accessories paragraph for both 50 Hz and 60 Hz codes).

● Not available.

Burner accessories

Nozzles type B5-AA 45°



The nozzles must be ordered separately. The following table shows the features and codes on the basis of the maximum required fuel output.

NOTE: each burner needs N° 1 nozzle.

BURNER	RATED DELIVERY (kg/h)	NOZZLE CODE (1)	NOZZLE CODE (2)
▶ ENNE/EMME 1400	70	3009203	3045426
▶ ENNE/EMME 1400	80	3009205	3045427
▶ ENNE/EMME 1400	90	3009207	3045428
▶ ENNE/EMME 1400 - 2000	100	3009209	3045430
▶ ENNE/EMME 1400 - 2000	125	3009211	3045432
▶ ENNE/EMME 1400 - 2000 - 3000	150	3009213	3045434
▶ ENNE/EMME 2000 - 3000	175	3009215	3045436
▶ ENNE/EMME 2000 - 3000 - 4500	200	3009800	3045438
▶ ENNE/EMME 3000 - 4500	225	3009801	3045440
▶ ENNE/EMME 3000 - 4500	250	3009802	3045442
▶ ENNE/EMME 3000 - 4500	275	3009803	3045444
▶ ENNE/EMME 3000 - 4500	300	3009804	3045446
▶ ENNE/EMME 4500	325	3009805	3045448
▶ ENNE/EMME 4500	350	3009806	3045450
▶ ENNE/EMME 4500	375	3009807	3045452
▶ ENNE/EMME 4500	400	3009808	3045454
▶ ENNE/EMME 4500	425	3009809	3045455
▶ ENNE/EMME 4500	450	3009810	3045456

(1) Nozzles Bergonzo B5 45° - with "AA" needle code.

(2) Nozzles Fluidics W2 45° - with "AA" needle code.

Spacer kit

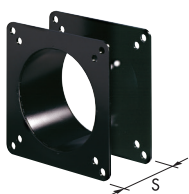

If burner head penetration into the combustion chamber needs reducing, varying thickness spacers are available, as given in the following list.

BURNER	SPACER THICKNESS S (mm)	KIT CODE
▶ ENNE/EMME 1400 - 2000	102	3000722
▶ ENNE/EMME 3000 - 4500	130	3000751

Modulating Dual Fuel Burners

ENNE/EMME SERIES

Burner accessories

Sound proofing box

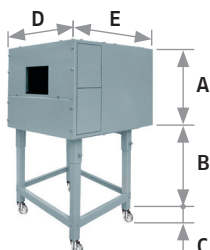

If noise emission needs reducing even further, sound-proofing boxes are available. In case of generator heights, where a lower dimension "B" is required, ask for the Box Support Kit code 20065135. The useful dimensions are 40 mm less than the total dimensions indicated in the table (A, D, E). Not suitable for outdoor use.

BURNER	BOX TYPE	A (mm)	B (mm) min-max	C (mm)	D (mm)	E (mm)	[dB(A)] (*)	BOX CODE
▶ ENNE/EMME 1400-2000 ENNE/EMME 3000-4500	C7	1255	160 - 980	110	1140	1345	10	3010376

(*) Average noise reduction according to EN 15036-1 standard

Accessories for modulating operation



To obtain modulating operation, the ENNE/EMME series of burners requires a regulator.

BURNER	REGULATOR TYPE	REGULATOR CODE
▶ ENNE/EMME 1400 - 2000 - 3000 - 4500	RWF 40	3010211



The relative temperature or pressure probes fitted to the regulator, must be chosen on the basis of the application.

BURNER	PROBE TYPE	RANGE (°C) (bar)	PROBE CODE
▶ ENNE/EMME 1400 - 2000 ENNE/EMME 3000 - 4500	Temperature PT 100	-100 ÷ 500°C	3010110
	Pressure 4 ÷ 20 mA	0 ÷ 2,5 bar	3010213
	Pressure 4 ÷ 20 mA	0 ÷ 16 bar	3010214
	Pressure 4 ÷ 20 mA	0 ÷ 25 bar	3090873



Depending on the servomotor fitted to the burner, a three-pole potentiometer (1000 Ω) can be installed to check the position of the servomotor.

BURNER	POTENTIOMETER KIT CODE
▶ ENNE/EMME 1400 - 2000 - 3000 - 4500	3010021

Burner accessories

LPG kit

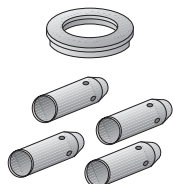

For burning LPG gas, a special kit is available to be fitted to the combustion head on the burner, as given in the following table.

BURNER	KIT CODE FOR STANDARD HEAD	KIT CODE FOR EXTENDED HEAD
▶ ENNE/EMME 1400 - 2000	3010063	3010063
▶ ENNE/EMME 3000	3090223	3090223
▶ ENNE/EMME 4500	3090937	3090937

Self-cleaning filter



For cleaning heavy oil from dirty particles and impurities, it is equipped with a thermostatic heater for oil with 60°E viscosity at 50°C.

FILTER TYPE	FILTERING DEGREE (µm)	FILTER CODE
▶ Ø = 1"1/2 (60°E at 50°C)	300	3010022

HEATER / THERMOSTAT TYPE	HEATER / THERMOSTAT CODE
▶ Thermostatic heater with LED	3010060
▶ Heater	3010061
▶ Thermostat (two-stage / regulable)	3010062

Degasing unit



In modulating burner, gas separator bottle connects the burner circuit to the main ring circuit. It allows to recover heat in excess by discharge of the gas from the return circuit.

BURNER	DEGASING UNIT CODE
▶ ENNE/EMME 1400 - 2000	3000748
▶ ENNE/EMME 3000 - 4500	3010012







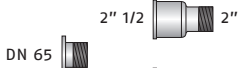
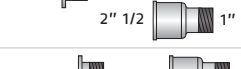

Modulating Dual Fuel Burners

ENNE/EMME SERIES

Gas train accessories

Adapters

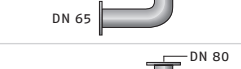
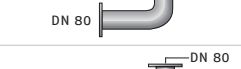
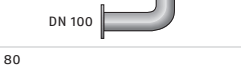
In certain cases, an adapter must be fitted between the gas train and the burner, when the diameter of the gas train is different from the set diameter of the burner. Below are given the available adapters; please see on the Gas Train list the correct adapter codes to select.

ADAPTER	LENGTH mm	ADAPTER CODE
 DN 65 2" 1/2 2"	300	3000825
 DN 65 2" 1/2 1" 1/2		
 DN 80 2" 1/2 2"	300	3000826
 1" 1/2 2"	35	3000843
 1" 1/4 2"	35	3010126
 DN 100 DN 80	50	3010370
 1" 1/2 2"	65	20064220
 2" 2"	65	20042324
 DN 65 DN 80	320	3000831
 DN 80 DN 80	320	3000832
 DN 100 DN 80	320	3010127
 DN 80 DN 65 2" 1/2 2"	540	3010128

Gas train accessories

Stabiliser spring



To vary the pressure range of the gas train stabilisers, accessory springs are available. The following table shows these accessories with their application range. Please refer to the technical manual for the correct choice of spring.

GAS TRAIN	SPRING COLOUR	SPRING PRESSURE RANGE mbar	SPRING CODE
▶ MBC 1900/1 - 3100/1 MBC 5000/1	White	4 - 20	3010381
	Red	20 - 40	3010382
	Black	40 - 80	3010383
	Green	80 - 150	3010384
▶ CB 512/1	Red	25 - 55	3010131
	Black	60 - 110	3010157
	Pink	90 - 150	3090486
▶ CB 520/1 - 525/1	Red	25 - 55	3010132
	Black	60 - 110	3010158
	Pink	100 - 150	3090487
▶ CB 5065/1 - 5080/1	Red	25 - 55	3010133
	Black	60 - 110	3010135
	Pink	100 - 150	3090456
	Grey	140 - 200	3090992
	Red	25 - 55	3010134
▶ CB 50100/1	Black	60 - 110	3010136
	Pink	100 - 150	3090489
	Grey	140 - 200	3092174
	Red	25 - 55	3010315
▶ CB 50125/1	Yellow	30 - 70	3010316
	Black	60 - 110	3010317
	Pink	100 - 150	3010318

Seal control kit



To test the valve seals on the gas train, a special "seal control kit" is available. The valve seal control device is compulsory (EN 676) on gas trains to burners with a maximum output over 1200 kW. The seal control is type VPS 504.

GAS TRAIN	KIT CODE for 50 Hz operation	KIT CODE for 60 Hz operation
▶ MB/1 type	3010123	20050030
▶ MBC/1 type	3010367	20029057
▶ CB/1 type	3010367	20029057