

- I** Bruciatori policombustibile gasolio/gas
- GB** Dual fuel Gas-Oil/Gas burners
- F** Brûleurs mixtes fioul/gaz
- D** Mehrstoffbrenner Heizöl/Gas
- E** Quemadores policombustible gasóleo / gas

Funzionamento bistadio progressivo o modulante lato gas / bistadio lato gasolio  
Oil progressive two-stage or modulating operation / Gas two-stage operation  
Fonctionnement fioul à deux allures progressives ou modulant / Fonctionnement gaz à deux allures  
Zweistufiger gleitender oder modulierender Betrieb für Öl / Zweistufig für Gas  
Funcionamiento a dos llamas progresivas o modulante lado gas / a dos llamas lado gasóleo

CODICE - CODE CÓDIGO	MODELLO - MODEL - MODELE MODELL - MODELO	TIPO - TYPE - TYP
3488100 - 3488110	RLS 190/M MZ	748 T
20011623 - 20011625	RLS 190/M MZ	748 T
20052642	RLS 190/M MZ	748 T

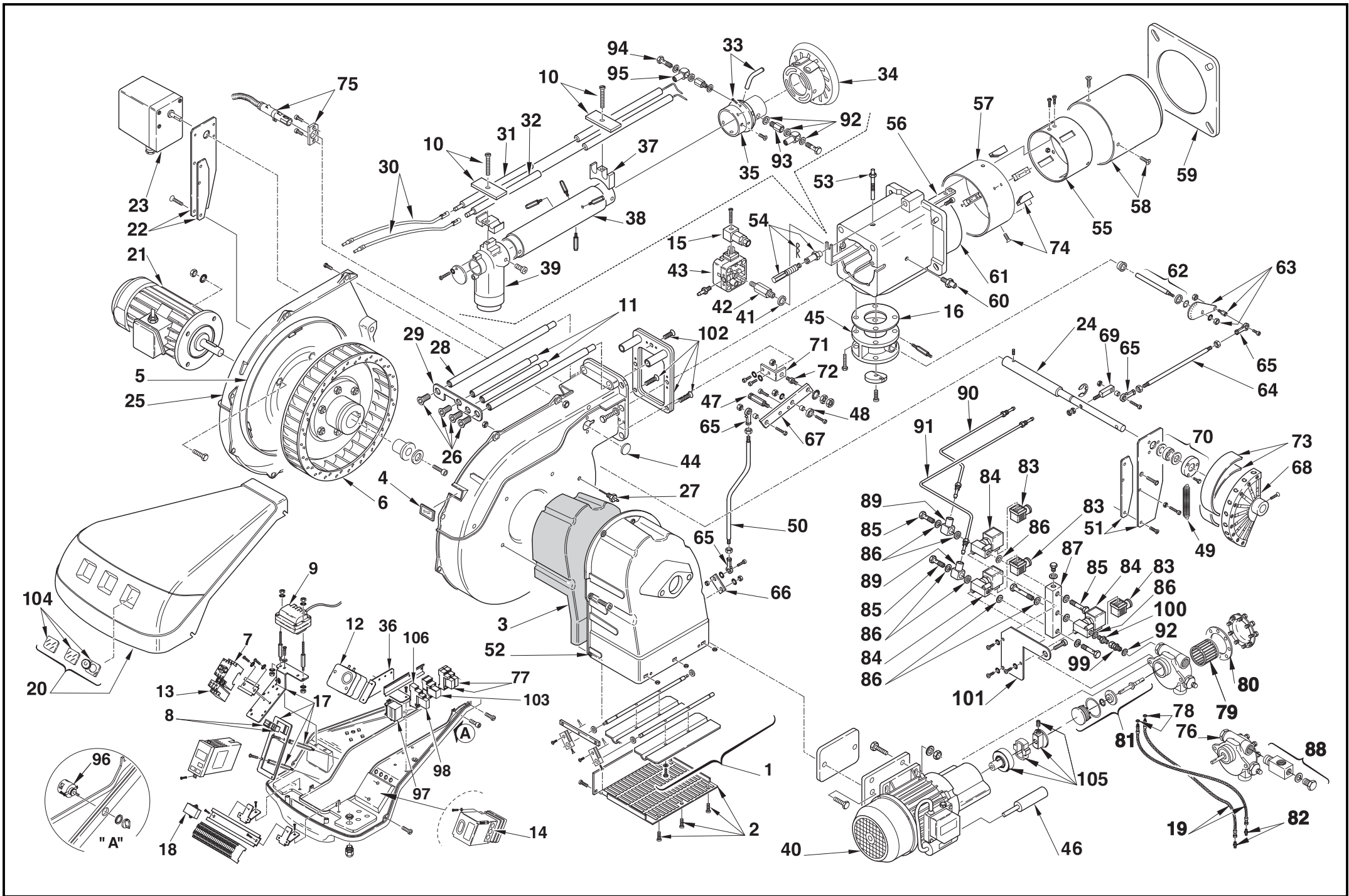

N.	COD.	3488100 - 3488110 20011623 - 20011625 20052642	DESCRIZIONE	DESCRIPTION	DESCRIPTION	BESCHREIBUNG	DENOMINACION	MATRICOLA BRUCIATORE BURNER SERIAL NUMBER MATRICULE BRULEUR BRENNER KENN-NUMMER MATRICULA QUEMADÓRES	*
1	3012583	•	GRUPPO SERRANDA	AIR DAMPER ASSEMBLY	GROUPE VOLET AIR	LUFTKLAPPE	CONJUNTO REGISTRO AIRE	≤ 02356xxxxxx	
1	3013684	•	GRUPPO SERRANDA	AIR DAMPER ASSEMBLY	GROUPE VOLET AIR	LUFTKLAPPE	CONJUNTO REGISTRO AIRE	≥ 02366xxxxxx	
1	3013684	•	GRUPPO SERRANDA	AIR DAMPER ASSEMBLY	GROUPE VOLET AIR	LUFTKLAPPE	CONJUNTO REGISTRO AIRE		
2	3003086	•	PROTEZIONE	GRID	PROTECTION	SCHUTZGITTER	PROTECION	≤ 02356xxxxxx	
2	3013683	•	PROTEZIONE	GRID	PROTECTION	SCHUTZGITTER	PROTECION	≥ 02366xxxxxx	
2	3013683	•	PROTEZIONE	GRID	PROTECTION	SCHUTZGITTER	PROTECION		
3	3012553	•	FONOASSORBENTE	SOUND DAMPING	INSONORISANT	GERÄUSCHDÄMMUNG	AISLAMIENTO ACÚSTICO	≤ 02356xxxxxx	C
3	3013682	•	FONOASSORBENTE	SOUND DAMPING	INSONORISANT	GERÄUSCHDÄMMUNG	AISLAMIENTO ACÚSTICO	≥ 02366xxxxxx	C
3	3013682	•	FONOASSORBENTE	SOUND DAMPING	INSONORISANT	GERÄUSCHDÄMMUNG	AISLAMIENTO ACÚSTICO		C
4	3003763	•	VISORE	INSPECTION WINDOW	VISEUR	SICHTFENSTER	VISOR		
5	3012573	•	ANELLO	PISTON SEAL	JOINT TORIQUE	LIPPENDICHTUNG	RACORD		B
6	3012555	•	GIRANTE	FAN	TURBINE	GEBLÄSERAD	TURBINA		C
7	3003637	•	CONTATTORE	CONTACTOR	CONTACTEUR	SCHÜTZ	CONTACTOR	≤ 02179xxxxxx	C
7	3013978	•	CONTATTORE	CONTACTOR	CONTACTEUR	SCHÜTZ	CONTACTOR	≥ 02189xxxxxx	C
7	3013978	•	CONTATTORE	CONTACTOR	CONTACTEUR	SCHÜTZ	CONTACTOR		C
8	3012080	•	INTERRUTTORE	SWITCH	INTERRUPTEUR	SCHALTER	INTERRUPTOR		C
9	3003785	•	TRASFORMATORE	TRANSFORMER	TRANSFORMATEUR	ZÜNDTRANSFORMATOR	TRANSFORMADOR		B
10	3012626	•	PIASTRINA	PLATE	PLAQUETTE ETRIER	PLATTE	PLATTE		
11	3012627	•	PROLUNGA PERNO	BAR EXTENSION	RALLONGE DE GLISSIERE	VERLÄNGERUNG	PROLUNGACIÓN PERNO	≤ 02356xxxxxx	
11	3013686	•	PROLUNGA PERNO	BAR EXTENSION	RALLONGE DE GLISSIERE	VERLÄNGERUNG	PROLUNGACIÓN PERNO	≥ 02366xxxxxx	
11	3013686	•	PROLUNGA PERNO	BAR EXTENSION	RALLONGE DE GLISSIERE	VERLÄNGERUNG	PROLUNGACIÓN PERNO		
11	3013687	•	PROLUNGA PERNO	BAR EXTENSION	RALLONGE DE GLISSIERE	VERLÄNGERUNG	PROLUNGACIÓN PERNO		
12	3007444	•	PRESSOSTATO ARIA	AIR PRESSURE SWITCH	PRESSOSTAT AIR	LUFTDRUCKWÄCHTER	PRESÓSTATO AIRE		A
13	3013676	•	RELE' TERMICO	OVERLOAD	RELAIS THERMIQUE	ÜBERSTROMAUSLÖSER	RELÉ TÉRMICO	≤ 02179xxxxxx	C
13	3013980	•	RELE' TERMICO	OVERLOAD	RELAIS THERMIQUE	ÜBERSTROMAUSLÖSER	RELÉ TÉRMICO	≥ 02189xxxxxx	C
13	3013676	•	RELE' TERMICO	OVERLOAD	RELAIS THERMIQUE	ÜBERSTROMAUSLÖSER	RELÉ TÉRMICO		C
14	3006090	•	APPARECCHIATURA	CONTROL BOX	BOITE DE CONTROLE	STEUERGERÄT	CAJA CONTROL		B
15	3012347	•	PRESA	SOCKET	PRISE	STECKBUCHSE	CONECTOR		C
16	3005482	•	GUARNIZIONE	SEAL	RONDELLE	FLANSCHDICHTUNG	JUNTA		B
17	3012343	•	SUPPORTO	SUPPORT	SUPPORT	HALTER	SOPORTE	≤ 02179xxxxxx	

N.	COD.	3488100 - 3488110 20011623 - 20011625 20052642	DESCRIZIONE	DESCRIPTION	DESCRIPTION	BESCHREIBUNG	DENOMINACION	MATRICOLA BRUCIATORE BURNER SERIAL NUMBER MATRICULE BRULEUR BRENNER KENN-NUMMER MATRICULA QUEMADORES	*
18	3012155	• • •	FILTRO ANTIDISTURBO	DEGLITCHER	FILTRE	ENTSTÖRER	FILTRO ANTI-INTERFEREN- CIA		C
19	3006182	• • •	TUBO FLESSIBILE	FLEXIBLE OIL LINE	FLEXIBLE	SCHLAUCH	TUBO FLEXIBLE		
20	3013119	• • •	COFANO	COVER	COFFRET	VERKLEIDUNG	ENVOLVENTE		
21	20050960	• • •	MOTORE	MOTOR	MOTEUR	MOTOR	MOTOR		C
22	3012585	• • •	PIASTRA	ANCHOR PLATE	PLATINE DE BLOCAGE	ARRETIERPLATTE	PLACA		
23	3012345	• • •	SERVOMOTORE	SERVOMOTOR	SERVOMOTEUR	STELLMOTOR	SERVOMOTOR		B
24	3012349	• • •	ALBERO	SHAFT	ARBRE	WELLE	ARBORILLO		
25	3012587	• • •	GUSCIO	HALF-SHELL	COUVERCLE	HAUBE	CÀSCARA		
26	3003481	•	VITE	SCREW	VIS	SCHRAUBE	TORNILLO	≤ 02356xxxxxx	
26	3013681	•	VITE	SCREW	VIS	SCHRAUBE	TORNILLO	≥ 02366xxxxxx	
26	3013681	•	VITE	SCREW	VIS	SCHRAUBE	TORNILLO		
27	3003891	• • •	RACCORDO	CONNECTOR	MAMELON	NIPPEL	RACORD		C
28	3012628	•	PERNO	BAR	GLISSIERE	BOLZEN	PERNO	≤ 02356xxxxxx	C
29	3012629	•	STAFFA	BRACKET	SUPPORT	KONSOLE	SOPORTE	≤ 02356xxxxxx	
30	3003795	• • •	COLLEGAMENTO ELET- TRODO	H.T. LEAD	CONNEXION POUR ELEC- TRODE	VERBINDUNG FÜR ELE- KTRODE	CABLE CONEXIÓ		A
31	3013172	• •	ELETTRODO	ELECTRODE	ELECTRODE PORCELAINE	ELEKTRODE	ELECTRODO		A
31	3013173	•	ELETTRODO	ELECTRODE	ELECTRODE PORCELAINE	ELEKTRODE	ELECTRODO		A
32	3013174	• •	ELETTRODO	ELECTRODE	ELECTRODE PORCELAINE	ELEKTRODE	ELECTRODO		A
32	3013175	•	ELETTRODO	ELECTRODE	ELECTRODE PORCELAINE	ELEKTRODE	ELECTRODO		A
33	3013422	• • •	TUBETTO	TUBE	TUYAU	RÖHRCHEN	TUBO		
34	3013420	• • •	TAZZA	AIR DIFFUSER	DIFFUSEUR D'AIR	FLAMMKOPFBECHER	DIFUSOR DEL AIRE		A
35	3013177	• • •	DISTRIBUTORE	GAS HEAD	DISTRIBUTEUR	GASVERTEILER	DISTRIBUIDOR		
36	3014216	• • •	SUPPORTO	SUPPORT	HALTER	SOPORTE	SOPORTE		
37	3013179	• • •	SUPPORTO	SUPPORT	SUPPORT	HALTER	SOPORTE		
38	3013418	• •	TUBO ESTERNO	EXTERIOR TUBE	TUYAU EXTERIEUR	AUSSERER ROHR	TUBO EXTERNO		
38	20056537	•	TUBO ESTERNO	EXTERIOR TUBE	TUYAU EXTERIEUR	AUSSERER ROHR	TUBO EXTERNO		
39	3012637	• • •	GOMITO	ELBOW	COUDE	SCHLITTEN	CODO		
40	3013180	•	MOTORE	MOTOR	MOTEUR	MOTOR	MOTOR	≤ 02436999999	C
40	3013829	• •	MOTORE	MOTOR	MOTEUR	MOTOR	MOTOR	≥ 02446000000	C
40	3013829	•	MOTORE	MOTOR	MOTEUR	MOTOR	MOTOR		C

N.	COD.	3488100 - 3488110 20011623 - 20011625 20052642	DESCRIZIONE	DESCRIPTION	DESCRIPTION	BESCHREIBUNG	DENOMINACION	MATRICOLA BRUCIATORE BURNER SERIAL NUMBER MATRICULE BRULEUR BRENNER KENN-NUMMER MATRICULA QUEMADÓRES	*
41	3007088	• • •	GUARNIZIONE	SEAL	RONDELLE	METALLDICHTUNG	JUNTA		C
42	3006615	• • •	RACCORDO	CONNECTOR	MAMELON	NIPPEL	RACORD		C
43	3003660	• • •	PRESSOSTATO GAS	GAS PRESSURE SWITCH	PRESSOSTAT GAZ	GAS DRUCKWÄCHTER	PRESÓSTATO GAS		B
44	3003996	• • •	TAPPO	PLUG	BOUCHON A VIS	SCHRAUBSTÖPSEL	TAPÓN		
45	3006096	• • •	REGOLATORE GAS	GAS REGULATOR	REGULATEUR GAZ	GAS REGLER	REGULACION GAS		C
46	3013182	•	CONDENSATORE	CONDENSER	CONDENSATEUR	KONDENSATOR	CONDENSADOR	≤ 02436999999	B
46	3013875	•	CONDENSATORE	CONDENSER	CONDENSATEUR	KONDENSATOR	CONDENSADOR	≥ 02446000000	B
46	3013875	•	CONDENSATORE	CONDENSER	CONDENSATEUR	KONDENSATOR	CONDENSADOR		B
47	3012352	• • •	PERNO	BAR	GLISSIERE	BOLZEN	PERNO		C
48	3003841	• • •	CUSCINETTO	BEARING	ROULEMENT	LAGER	COJINETE		
49	3012356	• • •	MOLLA	SPRING	RESSORT	FEDER	MUELLE		A
50	3012646	• • •	TIRANTE	TIE ROD	TIRANT	GESTÄNGE	TIRANTE		C
51	3012594	• • •	PIASTRA	ANCHOR PLATE	PLATINE DE BLOCAGE	ARRETIERPLATTE	PLACA		
52	3012828	•	BOCCA D'ASPIRAZIONE	AIR INTAKE	BOITIER D'ASPIRATION	ANSAUGÖFFNUNG	BOCA DE ASPIRACIÓN	≤ 02356xxxxxx	
53	3012049	• • •	VITE	SCREW	VIS	SCHRAUBE	TORNILLO		
54	3012639	• • •	GRUPPO REGOLATORE	CONTROL DEVICE	GROUPE OBTURATION	DRUCKREGULIERUNG	GRUPO REGULACION		C
55	3012560	• • •	OTTURATORE	SHUTTER	OBTURATEUR	SCHIEBER	OBTURADOR		C
56	3013419	• • •	STAFFA	BRACKET	SUPPORT	KONSOLE	SOPORTE		
57	3013421	• • •	CILINDRO	SLEEVE	CYLINDRE	ZYLINDER	CILINDRO		C
58	3012561	• • •	IMBUTO FIAMMA	END CONE	EMBOUT GUEULARD	FLAMMENROHR	TUBO EXTREMO		B
59	3012562	• • •	SCHERMO	FLANGE GASKET	ECRAN THERMIQUE	FLASCHDICHTUNG	JUNTA AISLANTE		A
60	3003322	• • •	RACCORDO	CONNECTOR	MAMELON	NIPPEL	RACORD		C
61	3013184	•	MANICOTTO	MANIFOLD	MANCHON	GASANSCHLUSS	COLARIN	≤ 02356xxxxxx	
62	3006132	• • •	ALBERO E ANELLO	SHAFT AND RING	ARBRE ET ANNEAU	WELLE UND RING	ÁRBOLILLO Y ANILLO		C
63	3012644	• • •	QUADRANTE	GRADUATE SECTOR	SECTEUR GRADUE	SKALENSEGMENT	SECTOR GRADUADO		C
64	3012600	•	TIRANTE	TIE ROD	TIRANT	GESTÄNGE	TIRANTE	≤ 02356xxxxxx	C
64	3003543	•	TIRANTE	TIE ROD	TIRANT	GESTÄNGE	TIRANTE	≥ 02366xxxxxx	C
64	3003543	•	TIRANTE	TIE ROD	TIRANT	GESTÄNGE	TIRANTE		C
65	3006098	• • •	SNODO SFERICO	PIN JOINT	CHAPE A ROTULE	KUGELGELENK	ARTICOLACION ESFERICA		C
66	3012601	• • •	LEVA	LEVER	LEVIER	HEBEL	PALANCA		C
67	3012354	• • •	LEVA	LEVER	LEVIER	HEBEL	PALANCA		C

N.	COD.	3488100 - 3488110 20011623 - 20011625 20052642	DESCRIZIONE	DESCRIPTION	DESCRIPTION	BESCHREIBUNG	DENOMINACION	MATRICOLA BRUCIATORE BURNER SERIAL NUMBER MATRICULE BRULEUR BRENNER KENN-NUMMER MATRICULA QUEMADORES	*
68	3012358	• • •	CAMMA	CAM	CAME	NOCKEN	EXCÉNTRICO		
69	3012350	• • •	LEVA	LEVER	LEVIER	HEBEL	PALANCA		C
70	3012357	• • •	CUSCINETTO	BEARING	ROULEMENT	LAGER	COJINETE		
71	3012602	• • •	SUPPORTO	SUPPORT	SUPPORT	HALTER	SOPORTE		
72	3012603	• • •	PERNO	BAR	GLISSIERE	BOLZEN	PERNO		
73	3006097	• • •	MOLLA	SPRING	RESSORT	FEDER	MUELLEA		C
74	3012647	• • •	BASETTA	CENTERING SUPPORT	ELEMENT DE CENTRAGE	ZENTRIERHALTERUNG	SOPORTE		
75	3003396	• • •	FOTOCPELLULAU.V.	DETECTOR	PHOTOCELLULE U.V.	U.V. PHOTOZELLE	FOTORESISTENCIA		A
76	3006369	• • •	POMPA	PUMP	POMPE	PUMPE	BOMBA		C
77	3013407	• • •	RELÈ + ZOCCOLO	RELAY + BASE	RELAIS + SOCLE	RELAIS + SOCKEL	RELÉ + ZOCALO		
78	3007164	• • •	GUARNIZIONE	SEAL	RONDELLE	METALLDICHTUNG	JUNTA		B
79	3006787	• • •	FILTRO	FILTER	FILTRE	FILTER	FILTRO		A
80	3006292	• • •	GUARNIZIONE	SEAL	RONDELLE	METALLDICHTUNG	JUNTA		B
81	3000805	• • •	ORGANO DI TENUTA	PUMP SEAL	ORGANE D'ETANCHEITE	WELLENDICHTUNG	CONJUNTO ESTANQUIDAD		B
82	3006181	• • •	RACCORDO	CONNECTOR	MAMELON	NIPPEL	RACORD		C
83	3006953	• • •	PRESA	HOLDER	PRISE CELLULE	SOCKEL	CONECTOR		B
84	3012002	• • •	VALVOLA	NEEDLEVALVE	VANNE POINTEAU	NADELVENTIL	VÁLVULA		
85	3003592	• • •	PERNO	BAR	GLISSIERE	BOLZEN	PERNO		C
86	3007077	• • •	GUARNIZIONE	SEAL	RONDELLE	METALLDICHTUNG	JUNTA		B
87	3012569	• • •	COLLETTORE	MANIFOLD	COLLECTEUR	SAMMLER	COLECTOR		C
88	3003681	• • •	RACCORDO	CONNECTOR	MAMELON	NIPPEL	RACORD		C
89	3006722	• • •	RACCORDO	CONNECTOR	MAMELON	NIPPEL	RACORD		C
90	3013423	• • •	TUBO	TUBE	TUYAUTERIE	DRUCKROHR	TUBO	≤ 02126999999	
90	3013672	• • •	TUBO	TUBE	TUYAUTERIE	DRUCKROHR	TUBO	≥ 02136000001; ≤ 02356xxxxxx	
90	3013709	• • •	TUBO	TUBE	TUYAUTERIE	DRUCKROHR	TUBO	≥ 02366xxxxxx	
90	3013709	• • •	TUBO	TUBE	TUYAUTERIE	DRUCKROHR	TUBO		
90	20056542	• • •	TUBO	TUBE	TUYAUTERIE	DRUCKROHR	TUBO		
91	3013424	• • •	TUBO	TUBE	TUYAUTERIE	DRUCKROHR	TUBO	≤ 02126999999	
91	3013673	• • •	TUBO	TUBE	TUYAUTERIE	DRUCKROHR	TUBO	≥ 02136000001; ≤ 02356xxxxxx	
91	3013710	• • •	TUBO	TUBE	TUYAUTERIE	DRUCKROHR	TUBO	≥ 02366xxxxxx	

N.	COD.	3488100 - 3488110 20011623 - 20011625 20052642	DESCRIZIONE	DESCRIPTION	DESCRIPTION	BESCHREIBUNG	DENOMINACION	MATICOLA BRUCIATORE BURNER SERIAL NUMBER MATRICULE BRULEUR BRENNER KENN-NUMMER MATICULA QUEMADÓRES	*
91	3013710	•	TUBO	TUBE	TUYAUTERIE	DRUCKROHR	TUBO		
91	20056544	•	TUBO	TUBE	TUYAUTERIE	DRUCKROHR	TUBO		
92	3007079	•••	GUARNIZIONE	SEAL	RONDELLE	METALLDICHTUNG	JUNTA		B
93	3013417	•••	RACCORDO	CONNECTOR	MAMELON	NIPPEL	RACORD		C
94	3003006	•••	PERNO	BAR	GLISSIERE	BOLZEN	PERNO		C
95	3006784	•••	RACCORDO	CONNECTOR	MAMELON	NIPPEL	RACORD		C
96	3012310	•••	COMMUTATORE	SELECTOR SWITCH	COMMUTATOR	WAHLSCHALTER	CONMUTADOR		
97	3013526	•••	RELÈ	RELAY	RELAIS	RELAIS	RELÉ		
98	3012368	•••	RELÈ	RELAY	RELAIS	RELAIS	RELÉ		
99	3013462	••	RACCORDO GIREVOLE	SWIVEL FITTING	TOURNANT	DREHANSCHLUSS	EMPALME GIRATORIO	≥ 02136000001	C
99	3013462	•	RACCORDO GIREVOLE	SWIVEL FITTING	TOURNANT	DREHANSCHLUSS	EMPALME GIRATORIO		C
100	3013185	••	RACCORDO	CONNECTOR	MAMELON	NIPPEL	RACORD	≥ 02136000001	C
100	3013185	•	RACCORDO	CONNECTOR	MAMELON	NIPPEL	RACORD		C
101	3013671	••	STAFFA	BRACKET	SUPPORT	KONSOLE	SOPORTE	≥ 02136000001	
101	3013671	•	STAFFA	BRACKET	SUPPORT	KONSOLE	SOPORTE		
102	3013685	••	GRUPPO PIASTRE	PLATES ASSEMBLY	GROUPE	PLATINES	PLATTENGRUPPE	≥ 02366xxxxxx	
102	3013685	•	GRUPPO PIASTRE	PLATES ASSEMBLY	GROUPE	PLATINES	PLATTENGRUPPE		
103	3014157	•••	RELÈ + ZOCCOLO	RELAY + BASE	RELAIS + SOCLE	RELAIS + SOCKEL	RELÉ + ZOCALO		
104	3013678	•••	MEMBRANA+VETRINO	MEMBRANE+VIEWING PORT	MEMBRANE+REGARD	MEMBRAN+VERSCHLUSS- TOPFEN	MEMBRANA+MIRILLA		
105	3013828	•••	GIUNTO	JOINT	ACCOUPLLEMENT	PUMPENKUPPLUNG	ACOPLAMIENTO		A
106	3003935	•••	ZOCCOLO	CONTROL BOX BASE	SOCLE	SOCKEL	ZOCALO		

★

**RICAMBI CONSIGLIATI - ADVISED PARTS - RECHANGE CONSEIL - EMPFOHLENE ERSATZTEILE - RECAMBIOS ACONSEJADOS**

A = Ricambi per dotazione minima - Spare parts for minimum fittings - Pièces détachées pour équipement minimum - Ersatzteile für minimale Ausstattung - Recambios para equipamiento mínimo  
A+B = Ricambi per dotazione base di sicurezza - Spare parts for basic safety fittings - Pièces détachées pour équipement standard de sécurité - Ersatzteile für Sicherheitsgrundausrüstung - Recambios para equipamiento básico de seguridad  
A+B+C = Ricambi per dotazione estesa di sicurezza - Spare parts for extended safety fittings - Pièces détachées pour équipement complet de sécurité - Ersatzteile für erweiterte Sicherheitsausrüstung - Recambios para equipamiento general de seguridad

---

**RIELLO**

RIELLO S.p.A.  
I-37045 Legnago (VR)  
Tel.: +39.0442.630111  
[http:// www.riello.it](http://www.riello.it)  
[http:// www.rielloburners.com](http://www.rielloburners.com)