

- I** Bruciatore di gas ad aria soffiata
- GB** Forced draught gas burner
- F** Brûleur gaz à air soufflé
- D** Gas-Gebläsebrenner
- E** Quemador de gas de aire soplado

Funzionamento bistadio progressivo
Two-stage progressive operation
Fonctionnement à 2 allures progressif
Zweistufiger gleitender Betrieb
Funcionamiento a dos llamas progresivas

CODICE - CODE CÓDIGO	MODELLO - MODEL - MODELE MODELL - MODELO	TIPO - TYPE - TYP
3752218	GAS 4/2	522 T1

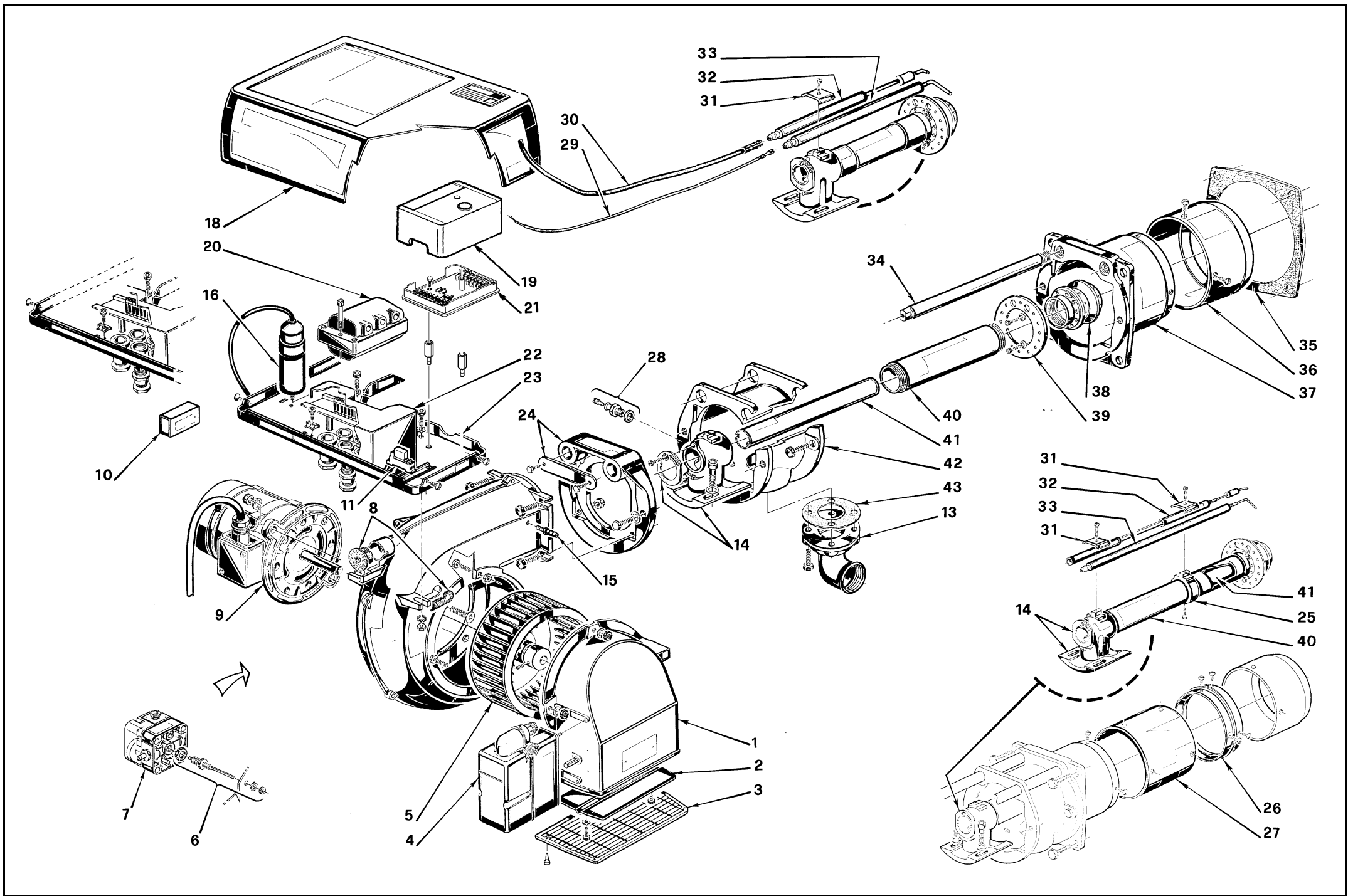

N.	COD.	DESCRIZIONE	DESCRIPTION	DESCRIPTION	BESCHREIBUNG	DENOMINACION	MATRICOLA BRUCIATORE BURNER SERIAL NUMBER MATRICULE BRULEUR BRENNER KENN-NUMMER MATRICULA QUEMADORES	RICAMBI CONSIGLIATI ADVISED PARTS RECHANGE CONSEIL EMPFOHLENE ERSATZTEILE RECAMBIOS A CONSEJADOS
								**
1	3003361	BOCCA D'ASPIRAZIONE	AIR INTAKE	BOITIER D'ASPIRATION	ANSAUGÖFFNUNG	BOCA ASPIRACION		
2	3003316	GRUPPO SERRANDA	AIR DAMPER ASSEMBLY	GROUPE VOLET	AIR LUFTKLAPPE	REGISTRO AIRE		
3	3003314	PROTEZIONE	GRID	PROTECTION	SCHUTZGITTER	PROTECIÓN		
4	3006311	MOTORINO SERRANDA	DAMPER MOTOR	SERVOMOTEUR VOLET D'AIR	LUFTKLAPPENSTELLMOTOR	SERVOMOTOR		B
5	3005443	GIRANTE	FAN	TURBINE	GEBLÄSERAD	TURBINA		C
6	3003499	RACCORDO PRESA ARIA	AIR PRESSURE SENSOR GROUP	UPRACCORD PRISE AIR	LUFTDRUCK SONDE	CONEXIÓN TOMA DEL AIRE		C
7	3006593	PRESSOSTATO ARIA	AIR PRESSURE SWITCH	PRESSOSTAT AIR	LUFTDRUCKWÄCHTER	PRESOSTATO DEL AIRE		A
8	3003406	PROTEZIONE	GRID	PROTECTION	SCHUTZGITTER	PROTECCIÓN		
9	3006612	MOTORE	MOTOR	MOTEUR	MOTOR	MOTOR		C
10	3012160	FILTRO ANTIDISTURBO	DEGLITCHER	FILTRE	ENTSTÖRER	FILTRO ANTI-INTERFERENCIA		C
11	3013407	RELE' TERMICO	THERMAL OVERLOAD	RELAIS THERMIQUE	ÜBERSTROMAUSLÖSER	RÉLE TÉRMICO	≥ 02215000058	C
12								
13	3006802	FLANGIA E GOMITO	FLANGE AND ELBOW	BRIDE ET COUDE	ANSCHLUSSFLANSCHGAS	BRIDA Y CODO		
14	3006852	GOMITO E GHIERA	ELBOW AND FERRULE	COUDE ET DISQUE	SCHLITTEN UND STELLRING	DISCO Y CODO		
*14	3003412	GOMITO E GHIERA	ELBOW AND FERRULE	COUDE ET DISQUE	SCHLITTEN UND STELLRING	DISCO Y CODO		
15	3003322	RACCORDO	CONNECTOR	MAMELON	NIPPEL	RACORD		C
16	20087030	CONDENSATORE	CONDENSER	CONDENSATEUR	KONDENSATOR	CONDENSADOR		B
17								
18	3003387	COPERCHIO	COVER	COUVERCLE	DECKEL	TAPA		
19	3013073	APPARECCHIATURA	CONTROL BOX	BOITE DE CONTROLE	STEUERGERÄT	CAJA CONTROL		B
20	3012159	TRASFORMATORE	TRANSFORMER	TRANSFORMATEUR	ZÜNDTRANSFORMATOR	TRASFORMADOR		B
21	3003784	ZOCCOLO	BASE	SOCLE	SOCKEL	ZOCÁLO		C
22	3003071	COPERCHIO	COVER	COUVERCLE	PVC ABDECKUNG	ENVOLVENTE		
23	3003328	MENSOLA	BASE PLATE	PLAQUE DE SUPPORT	GRUNDPLATE	SOPORTE		
24	3003501	COLLARE	COLLAR	COLLER	INNERER FLANSCH	COLLARÍN		
*25	3003357	SUPPORTO ELETTRODI	ELECTRODE BRACKET	SUPPORT ELECTRODES	ELEKTRODEN HALTERUNG	CORCHETE DEL ELECTRODO		
*26	3000564	DENTE	CONNECTION SLEEVE	JONCTION	STAURING	ANILLO LLAMA		
*27	3000565	CILINDRO	SLEEVE	CYLINDRE	ZYLINDER	CILINDRO		
28	3005447	GRUPPO MISURAZIONE	TEST POINT	PRISE DE PRESSION	MESSNIPPEL	GRUPO TOMA DE PRESION		
29	3005442	COLLEGAMENTO PER SONDA	PROBE LEAD	CONNEXION POUR SONDE	VERBINDUNG FÜR SONDE	CABLE SONDA DE IONIZACIÓN		A
30	3003794	COLLEGAMENTO PER ELETTRODO	H.T. LEAD	CONNEXION POUR ELECTRODE	VERBINDUNG FÜR ELEKTRODE	CABLE ELECTRODO		A
31	3003409	CAVALLOTTO	U BOLT	CAVALIER	BÜGELBOLZEN	FIJACION ELECTRODO		
32	3005593	ELETTRODO CORTO	SHORT ELECTRODE	ELECTRODE COURTE	KURZE ELEKTRODE	ELECTRODO CORTO		A
*32	3000624	ELETTRODO LUNGO	LONG ELECTRODE	ELECTRODE LONGUE	LANGE ELEKTRODE	ELECTRODO LARGO		A
33	3012173	SONDA CORTA	SHORT PROBE	SONDE COURTE	KURZE JONISATIONSELEKTRODE	SONDA CORTA		A
*33	3012182	SONDA LUNGA	LONG PROBE	SONDE LONGUE	LANGE JONISATIONSELEKTRODE	SONDA LARGA		A
34	3003389	PERNO	BAR	GLISSIERE	BOLZEN	GUAÍA		
35	3005741	SCHERMO	FLANGE GASKET	ECRAN THERMIQUE	FLANSCHDICHTUNG	JUNTA AISLANTE		A
36	3005450	IMBUTO FIAMMA	END CONE	EMBOUT GUEULARD	FLAMMENROHR	TUBO EXTREMO		B
37	3005448	BOCCAGLIO	BLAST TUBE	GUEULARD	BRENNERFLANSCH	TUBO LLAMA		
38	3006058	DISTRIBUTORE	GAS HEAD	DISTRIBUTEUR	GASVERTEILER	PORTABOQUILLA		
39	3006052	DISCO	DISC	DISQUE	SCHIBE	TUBO LLAMA		A
40	3006641	TUBO ESTERNO	EXTERIOR TUBE	TUYAU EXTERIEUR	AUSSERER ROHR	TUBO EXTERNO		
*40	3003410	TUBO ESTERNO	EXTERIOR TUBE	TUYAU EXTERIEUR	AUSSERER ROHR	TUBO EXTERNO		

N.	COD.	DESCRIZIONE	DESCRIPTION	DESCRIPTION	BESCHREIBUNG	DENOMINACION	MATRICOLA BRUCIATORE BURNER SERIAL NUMBER MATRICULE BRULEUR BRENNER KENN-NUMMER MATRICULA QUEMADORES	RICAMBI CONSIGLIATI ADVISED PARTS RECHANGE CONSEIL EMPFOHLENE ERSATZTEILE RECAMBIOS ACONSEJADOS
41	3006631	TUBO INTERNO	INTERIOR TUBE	TUYAU INTERIEUR	INNERER ROHR	TUBO INTERNO		
*41	3003408	TUBO INTERNO	INTERIOR TUBE	TUYAU INTERIEUR	INNERER ROHR	TUBO INTERNO		**
42	3003334	MANICOTTO	MANIFOLD	MANCHON	GASANSCHLUSS	COLLARÍN		
43	3005483	GUARNIZIONE	SEAL	RONDELLE	FLANSCHDICHTUNG	COLLARÍN		B

**

* = Versione Testa Lunga - Long Combustion Head Version - Version Tête Longue - Langer Brennkopf Ausführung - Versión alargado de tubo llama

A = Ricambi per dotazione minima - Spare parts for minimum fittings - Pièces détachées pour équipement minimum - Ersatzteile für minimale Ausstattung - Recambios para equipamiento mínimo

A+B = Ricambi per dotazione base di sicurezza - Spare parts for basic safety fittings - Pièces détachées pour équipement standard de sécurité - Ersatzteile für Sicherheitsgrundausrüstung - Recambios para equipamiento básico de seguridad

A+B+C = Ricambi per dotazione estesa di sicurezza - Spare parts for extended safety fittings - Pièces détachées pour équipement complet de sécurité - Ersatzteile für erweiterte Sicherheitsausstattung - Recambios para equipamiento general de seguridad

RIELLO

RIELLO S.p.A.
I-37045 Legnago (VR)
Tel.: +39.0442.630111
[http:// www.riello.it](http://www.riello.it)
[http:// www.riello.com](http://www.riello.com)