

- I** Bruciatore di gas ad aria soffiata
- GB** Forced draught gas burner
- F** Brûleur gaz à air soufflé
- D** Gas-Gebläsebrenner
- E** Quemador de gas de aire soplado

Funzionamento monostadio
One stage operation
Fonctionnement à 1 allure
Einstufiger Betrieb
Funcionamiento a 1 llama

CODICE - CODE CÓDIGO	MODELLO - MODEL - MODELE MODELL - MODELO	TIPO - TYPE - TYP
3761971	Gulliver RS5F	920T1

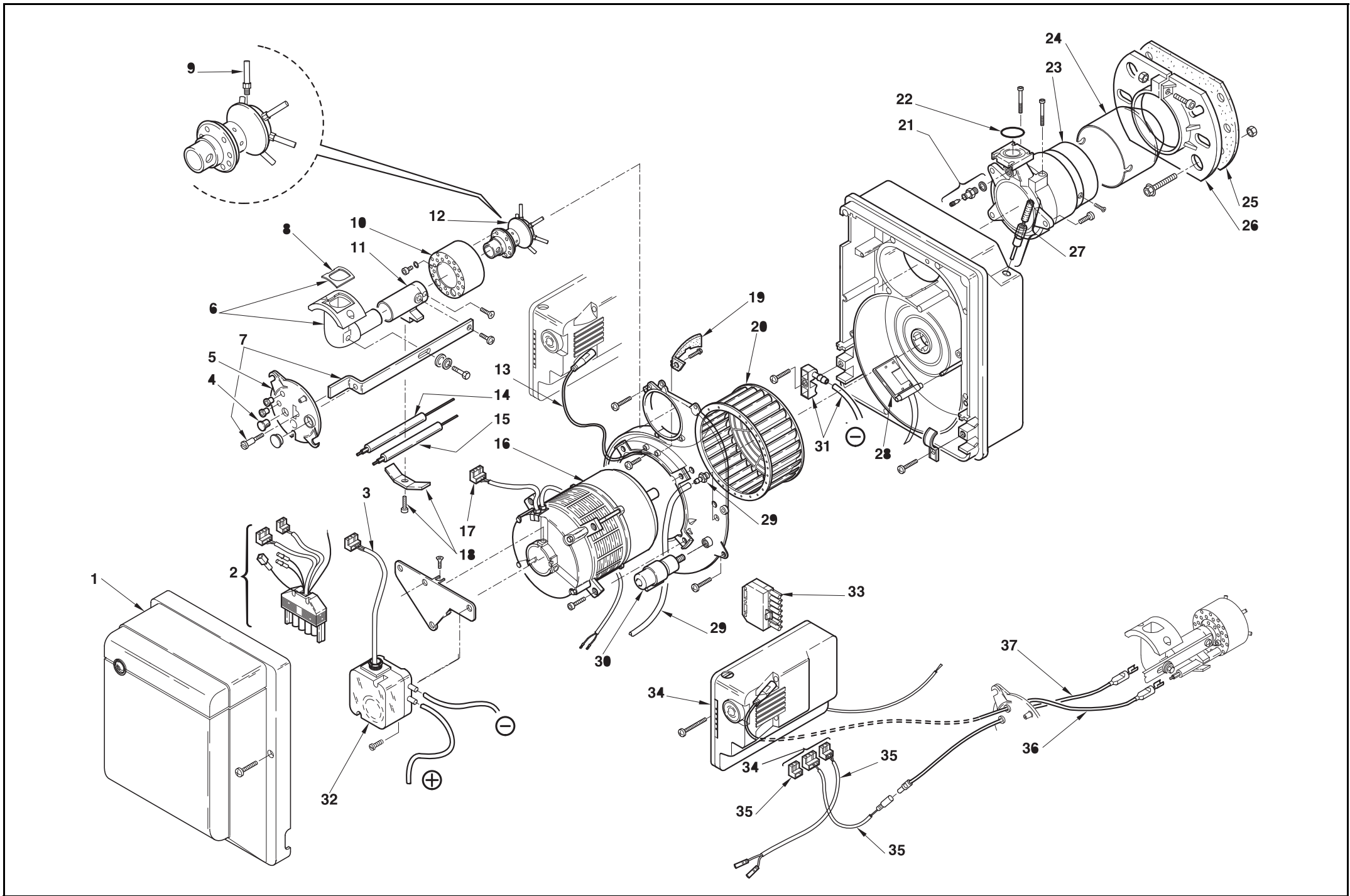

N.	COD.	DESCRIZIONE	DESCRIPTION	DESCRIPTION	BESCHREIBUNG	DENOMINACION	MATRICOLA BRUCIATORE BURNER SERIAL NUMBER MATRICULE BRULEUR BRENNER KENN-NUMMER MATRICULA QUEMADÓRES	*
1	3008496	COFANO	COVER	CAPOT	VERKLEIDUNG	TAPA		B
2	3002979	GRUPPO COLLEGAMENTI	ASSEMBLY CONNECTION	GROUPE DE CONNEXION	VERBINDUNGSSYSTEM	ENCHUFE CONECTORES		
3	3002972	COLLEGAMENTO PRESSO-STATO	PRESSURE SWITCH CONNECTION	CONNEXION PRESSOSTAT	DRUCKWÄCHTERVERBINDUNG	CONEXIÓN PRESOSTATO		A
4	3007458	VETRINO	VIEWING PORT	REGARD	VERSCHLUßSTOPFEN	MIRILLA		
5	3007642	COPERCHIO	COVER	COUVERCLE	DECKEL	TAPA		
6	3007979	GOMITO	ELBOW	COUDE	SCHLITTEN	CODO		
7	3008505	STAFFA E VITE	BRACKET AND SCREW	SUPPORT ET VIS	DÜSENSTOCKHALTERUNG	SOPORTE ARRASTRE Y TOR-NILLO		
8	3002560	GUARNIZIONE	SEAL	JOINT	DICHTUNG	JUNTA		B
9	3008504	TUBO	TUBE	TUYAU	RÖHRCHEN	TUBO		C
10	3008501	TAZZA	AIR DIFFUSER	DIFFUSEUR D'AIR	STAUSCHEIBE	DIFUSOR DEL AIRE		
11	3007992	PROLUNGA GOMITO	ELBOW EXTENSION	EXTENSION COUDE	SCHLITTENVERLÄNGERUNG	EXTENSIÓN CODO		
12	3002969	DISTRIBUTORE	DISTRIBUTOR	DISTRIBUTEUR	GASKOPF	DISTRIBUIDOR		
13	3002494	COLLEGAMENTO	CONNECTION	CONNEXION	VERBINDUNG	CONEXIÓN		A
14	3007988	SONDA	PROBE	SONDE	FÜHLER	SONDA		A
15	3008932	ELETTRODO	ELECTRODE	ELECTRODE	ELEKTRODE	ELECTRODO		A
16	3008506	MOTORE	MOTOR	MOTEUR	MOTOR	MOTOR		C
17	3007454	PRESA MOTORE	MOTOR SOCKET	PRISE MOTEUR	STECKDOSE FÜR MOTOR	CONECTOR MOTOR		C
18	3007265	CAVALLOTTO	U BOLT	CAVALIER	BÜGELBOLZEN	SOPORTE FIJACION		
19	3008552	CONVOGLIATORE	SUCTION DUCT	CONVOYEUR D'AIR	LUFTLEITBLECH	GUÍA		
20	3008494	GIRANTE	FAN	TURBINE	GEBLÄSERAD	TURBINA		C
21	3005447	GRUPPO MISURAZIONE	TEST POINT	PRISE DE PRESSION	MESSNIPPEL	GRUPO TOMA DE PRESIÓN		
22	3008005	ANELLO DI TENUTA	O-RING SEAL	JOINT D'ETANCHEITE	O-RING-DICHTUNG	JUNTA TÓRICA		B
23	3008502	MANICOTTO	MANIFOLD	MANCHON	FLAMMKOPF MIT GASAN-SCHLUß	COLLARÍN		
24	3002469	TUBO FIAMMA	FLAME TUBE	GUEULARD	FLAMMROHR	TUBO LLAMA		
25	3008500	SCHERMO	FLANGE GASKET	ECRAN THERMIQUE	KESSELFLANSCH-DICHTUNG	JUNTA AISLANTE		A
26	3008493	FLANGIA	FLANGE	BRIDE	KESSELFLANSCH	BRIDA		
27	3002455	REGOLATORE SERRANDA ARIA	AIR DAMPER REGULATOR	SYSTEME REGLAGE D'AIR	LUFTREGULIERUNG	REGULADOR REGISTRO AIRE		
28	3002866	SERRANDA ARIA	AIR DAMPER	VOLET D'AIR	LUFTKLAPPE	REGISTRO DEL AIRE		
29	3006605	RACCORDO E TUBETTO	CONNECTOR AND TUBE	MAMELON ET TUYAU	NIPPEL UND RÖHRCHEN	RACORD Y TUBO		
30	20087038	CONDENSATORE	CAPACITOR	CONDENSATEUR	KONDENSATOR	CONDENSADOR		C
31	3008017	RACCORDO E TUBETTO	CONNECTOR AND TUBE	MAMELON ET TUYAU	NIPPEL UND RÖHRCHEN	RACORD Y TUBO		
32	3007444	PRESSOSTATO ARIA	AIR PRESSURE SWITCH	PRESSOSTAT AIR	LUFTDRUCKWÄCHTER	PRESÓSTATO AIRE		A
33	3006937	SPINA 7 POLI	7 PIN PLUG	FICHE 7 PÔLES	7-POLIGER STECKER	CONECTOR MACHO DE 7 CONTACTOS		A
34	3002967	APPARECCHIATURA	CONTROL BOX	BOÎTE DE CONTRÔLE	STEUERGERÄT	CAJA DE CONTROL		B
35	3002971	GRUPPO COLLEGAMENTI	ASSEMBLY CONNECTION	GROUPE DE CONNEXION	VERBINDUNGSSYSTEM	ENCHUFE CONECTORES		
36	3008491	COLLEGAMENTO ELETTRODO	ELECTRODE CONNECTION	CONNEXION ELECTRODE	ELEKTRODEVERBINDUNG	CONEXIÓN ELECTRODO		A
37	3008490	COLLEGAMENTO SONDA	PROBE CONNECTION	CONNEXION SONDE	FÜHLERVERBINDUNG	CONEXIÓN SONDA		A

*

RICAMBI CONSIGLIATI - ADVISED PARTS - RECHANGE CONSEIL - EMPFOHLENE ERSATZTEILE - RECAMBIOS ACONSEJADOS

A = Ricambi per dotazione minima - Spare parts for minimum fittings - Pièces détachées pour équipement minimum - Ersatzteile für minimale Ausstattung - Recambios para equipamiento mínimo

A+B = Ricambi per dotazione base di sicurezza - Spare parts for basic safety fittings - Pièces détachées pour équipement standard de sécurité - Ersatzteile für Sicherheitsgrundausrüstung - Recambios para equipamiento básico de seguridad

A+B+C = Ricambi per dotazione estesa di sicurezza - Spare parts for extended safety fittings - Pièces détachées pour équipement complet de sécurité - Ersatzteile für erweiterte Sicherheitsausstattung - Recambios para equipamiento general de seguridad

The logo for RIELLO, consisting of the word "RIELLO" in a bold, red, sans-serif font.

RIELLO S.p.A.
I-37045 Legnago (VR)
Tel.: +39.0442.630111
[http:// www.riello.it](http://www.riello.it)
[http:// www.riello.com](http://www.riello.com)