

- I** Bruciatori di gas ad aria soffiata
- GB** Forced draught gas burners
- F** Brûleurs gaz à air soufflé
- D** Gas-Gebläsebrenner
- E** Quemadores de gas de aire soplado

Funzionamento monostadio
One stage operation
Fonctionnement à 1 allure
Einstufiger Betrieb
Funcionamiento a 1 llama

CODICE - CODE CÓDIGO	MODELLO - MODEL - MODELE MODELL - MODELO	TIPO - TYPE - TYP
3768000	RDBS1	960 T

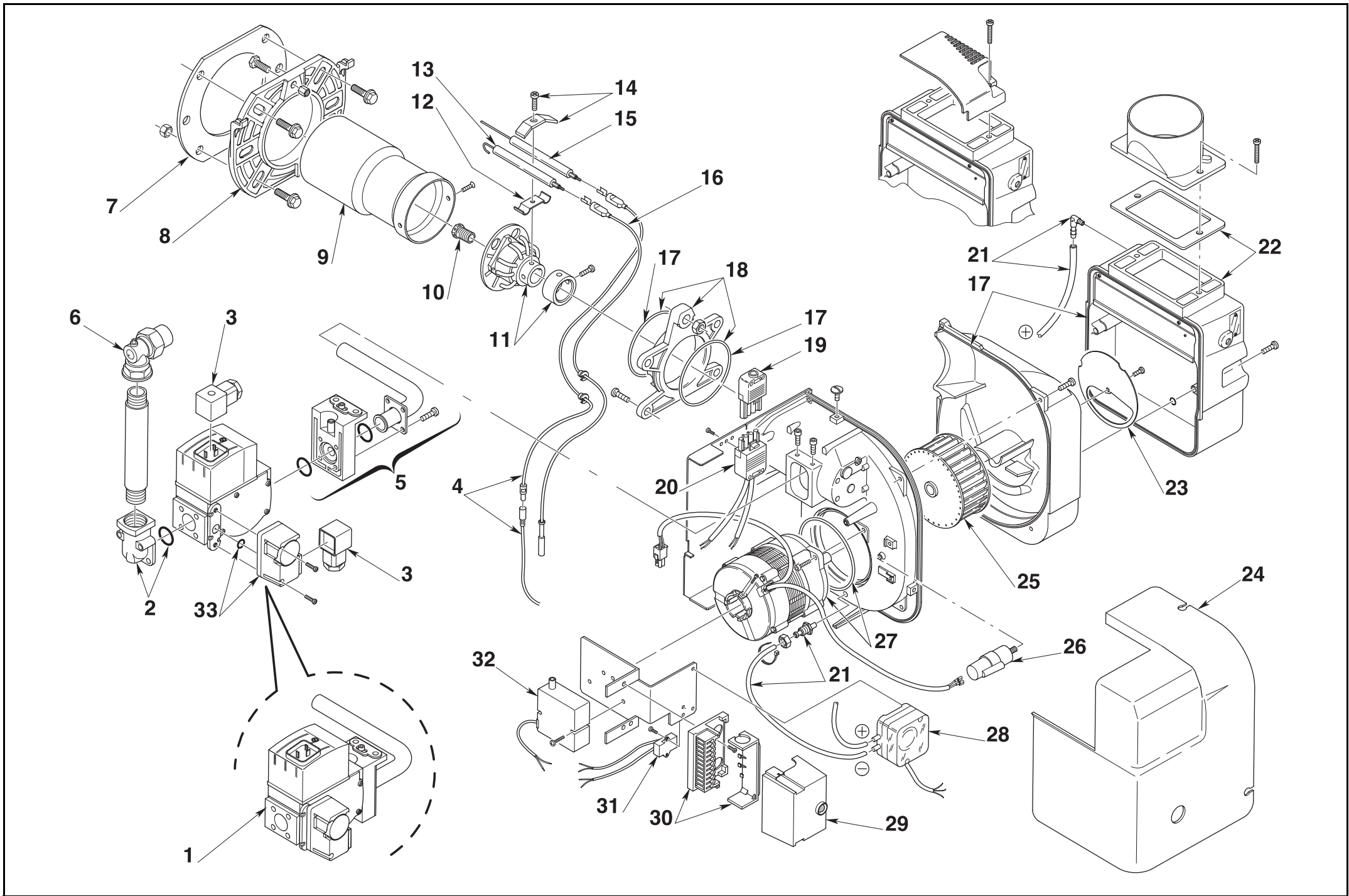

N.	COD.	DESCRIZIONE	DESCRIPTION	DESCRIPTION	BESCHREIBUNG	DENOMINACION	MATRICOLA BRUCIATORE BURNER SERIAL NUMBER MATRICULE BRULEUR BRENNER KENN-NUMMER MATRICULA QUEMADÓRES	*
1	3002589	RAMPA GAS	GAS TRAIN	RAMPE GAZ	GASSTRECKE	RAMPA GAS		
2	3002592	FLANGIA PER RAMPA GAS	FLANGE FOR GAS TRAIN	BRIDE POUR RAMPE GAZ	KESSELFLANSCH FÜR GASSTRECKE	BRIDA PARA RAMPA GAS		
3	3006954	PRESA	SOCKET	PRISE	STECKER	CONECTOR		
4	3002586	COLLEGAMENTO SONDA	LEAD	CABLE DE CONNEXION	IONISATIONSKABEL	CABLE CONEXIÓN		
5	3002590	SUPPORTO VALVOLA E TUBO	VALVE AND TUBE SUPPORT	SUPPORT VANNE ET TUYAU	VENTIL- UND ROHRHALTERUNG	SOPORTE VÁLVULA Y TUBO		
6	3002593	RACCORDO	CONNECTOR	MAMELON	ANSCHLUßNIPPEL	RACORD		
7	3005787	SCHERMO	GASKET	JOINT ISOLANT	KESSELFLANSCH-DICHTUNG	JUNTA AISLANTE		
8	3006384	FLANGIA	FLANGE	BRIDE	KESSELFLANSCH	BRIDA		
9	3002588	BOCCAGLIO	BLAST TUBE	GUEULARD	FLAMMROHR	TUBO LLAMA		
10	3006701	DIFFUSORE	DIFFUSER	DIFFUSEUR	DIFFUSOR	DIFUSOR DEL AIRE		
11	3002587	DISTRIBUTORE	DISTRIBUTOR	DISTRIBUTEUR	GASKOPF	DISTRIBUIDOR		
12	3007664	SUPPORTINO	SUPPORT	SUPPORT	HALTEBÜGEL	SOPORTE FIJACIÓN		
13	3002584	ELETTRODO	ELECTRODE	ELECTRODE	ZÜNDELEKTRODE	ELECTRODO		
14	3007265	CAVALLOTTO	U BOLT	CAVALIER	BÜGELBOLZEN	SOPORTE FIJACIÓN		
15	3002594	SONDA	PROBE	SONDE	IONISATIONSELEKTRODE	SONDA		
16	3002585	COLLEGAMENTO A.T.	HIGH VOLTAGE LEAD	CABLE HAUTE TENSION	KABEL ZÜNDELEKTRODEN	CABLES ELECTRODOS		
17	3008878	KIT GUARNIZIONI	KIT SEALS	KIT JOINTS	DICHTUNG ERSATZ	KIT JUNTAS		
18	3002583	COLLARE	COLLAR	COLLIER	BRENNERFLANSCH	COLLARÍN		
19	3007418	SPINA A 4 POLI	4 PIN PLUG	FICHE 4 POLES	4 - POLIGER STECKER	CONECTOR MACHO DE 4 CONTACT.		
20	3007417	PRESA A 4 POLI	4 POLE SOCKET	PRISE 4 POLES	4 - POLIGE STECKDOSE	CONECTOR HEMBRA DE 4 CONTACT.		
21	3002578	PRESE DI PRESSIONE	PRESSURE GAUGE	PRISE DE PRESSION	LUFTDRUCKANSCHLUß	TOMA DE PRESIÓN		
22	3002577	GRUPPO SERRANDA ARIA	AIR DAMPER ASSEMBLY	SYSTEME REGLAGE D'AIR	LUFTREGULIERUNG	REG. REGISTRO DEL AIRE		
23	3002579	SERRANDA ARIA	AIR DAMPER	VOLET D'AIR	LUFTKLAPPE	REGISTRO DEL AIRE		
24	3002591	COFANO	COVER	CAPOT	BRENNERHAUBE	ENVOLVENTE		
25	3005708	GIRANTE	FAN	TURBINE	GEBLÄSERAD	TURBINA		
26	20090008	CONDENSATORE 2 µF	CAPACITOR 2 µF	CONDENSATEUR 2 µF	KONDENSATOR 2 µF	CONDENSADOR 2 µF		
27	3002582	MOTORE	MOTOR	MOTEUR	MOTOR	MOTOR		
28	3002316	PRESSOSTATO ARIA	AIR PRESSURE SWITCH	PRESSOSTAT AIR	LUFTDRUCKWÄCHTER	PRESÓSTATO AIRE		
29	3002580	APPARECCHIATURA LMG25	CONTROL BOX LMG25	BOITE DE CONTROLE LMG25	STEUERGERÄT LMG25	CAJA DE CONTROL LMG25		
30	3003596	ZOCCOLO	CONTROL BOX BASE	BORNIER	STECKSOCKEL	ZOCALO		

N.	COD.	DESCRIZIONE	DESCRIPTION	DESCRIPTION	BESCHREIBUNG	DENOMINACION	MATRICOLA BRUCIATORE BURNER SERIAL NUMBER MATRICULE BRULEUR BRENNER KENN-NUMMER MATRICULA QUEMADORES	*
31	3002581	FILTRO ANTIDISTURBI RADIO	SUPPRESSOR	ANTIPARASITE	FUNK-ENSTÖRFILTER	FILTRO ANTIINTERFERENCIAS RADIO		
32	3002475	TRASFORMATORE	TRANSFORMER	TRANSFORMATEUR	ZÜNDTRANSFORMATOR	TRANSFORMADOR		
33	3012196	PRESSOSTATO GAS	GAS PRESSURE SWITCH	PRESSOSTAT GAZ	GASDRUCKWÄCHTER	PRESÓSTATO GAS		

*

RICAMBI CONSIGLIATI - ADVISED PARTS - RECHANGE CONSEIL - EMPFOHLENE ERSATZTEILE - RECAMBIO ACONSEJADOS

A = Ricambi per dotazione minima - Spare parts for minimum fittings - Pièces détachées pour équipement minimum - Ersatzteile für minimale Ausstattung - Recambios para equipamiento mínimo

A+B = Ricambi per dotazione base di sicurezza - Spare parts for basic safety fittings - Pièces détachées pour équipement standard de sécurité - Ersatzteile für Sicherheitsgrundausrüstung - Recambios para equipamiento básico de seguridad

A+B+C = Ricambi per dotazione estesa di sicurezza - Spare parts for extended safety fittings - Pièces détachées pour équipement complet de sécurité - Ersatzteile für erweiterte Sicherheitsausrüstung - Recambios para equipamiento general de seguridad

RIELLO

RIELLO S.p.A.

I-37045 Legnago (VR)

Tel.: +39.0442.630111

[http:// www.riello.it](http://www.riello.it)

[http:// www.riello.com](http://www.riello.com)