

- I** Bruciatori di gas ad aria soffiata
- GB** Forced draught gas burners
- F** Brûleurs gaz à air soufflé
- D** Gas-Gebläsebrenner
- E** Quemadores de gas de aire soplado

Funzionamento bistadio progressivo o modulante
Progressive two-stage or modulating operation
Fonctionnement à 2 allures progressives ou modulant
Gleitend-zweistufiger oder modulierender Betrieb
Funcionamiento a dos llamas progresivas o modulante

COD.	MOD.	TYP.
3789900 - 3789910	RS 64/E MZ	896 T
3789901 - 3789911	RS 64/E MZ	896 T

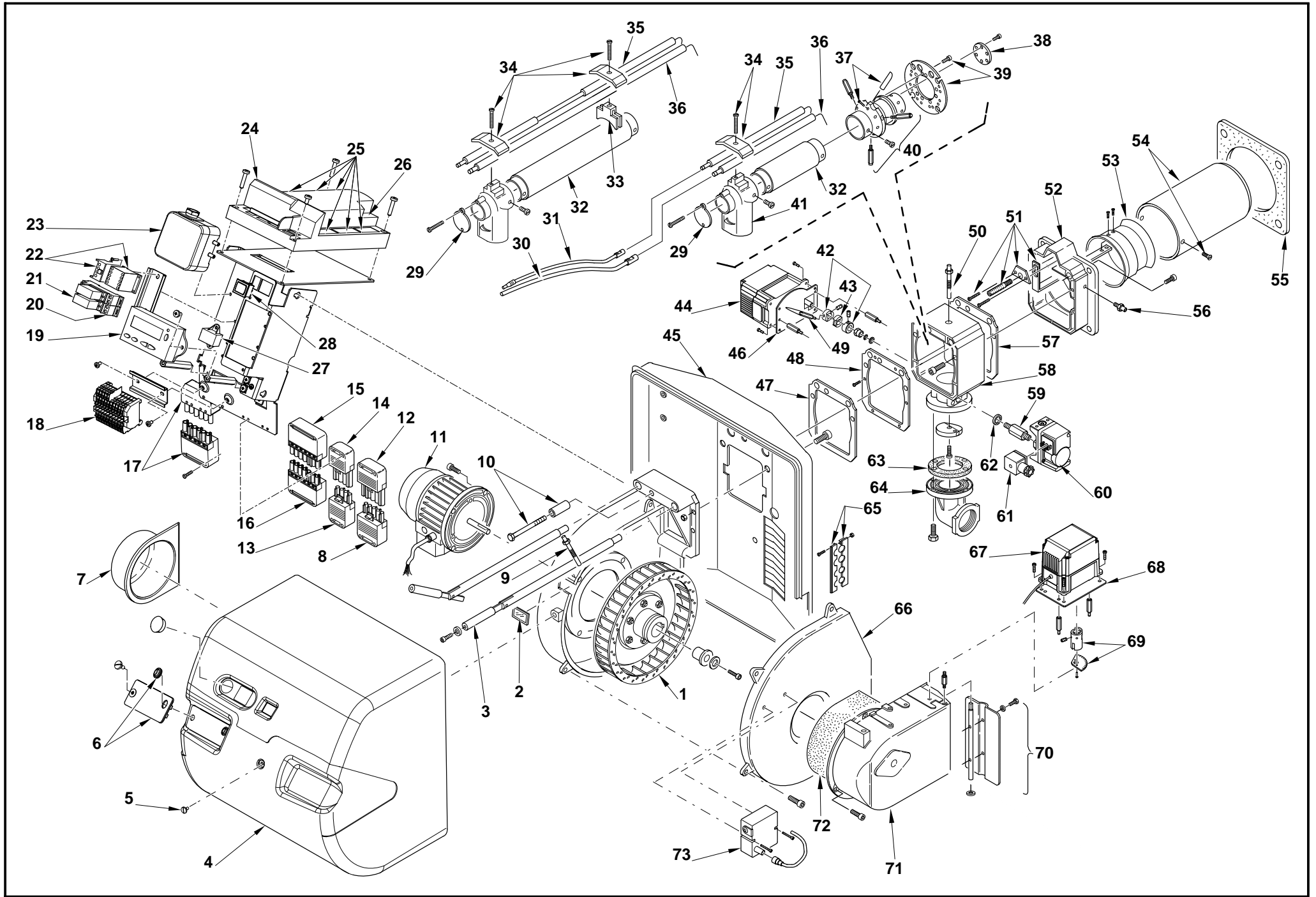

N.	COD.	3788900 3788901 *	DESCRIZIONE	DESCRIPTION	DESCRIPTION	BESCHREIBUNG	DENOMINACION	MATRICOLA BRUCIATORE BURNER SERIAL NUMBER MATRICULE BRULEUR BRENNER KENN-NUMMER MATRICULA QUEMADÓRES	**
1	3013768	• •	GIRANTE	FAN	TURBINE	GEBLÄSERAD	TURBINA		C
2	3003763	• •	VISORE	INSPECTION WINDOW	WISEUR	SICHTFENSTER	VISOR		
3	3013769	• •	PERNO	BAR EXTENSION	RALLONGE DE GLISSIERE	VERLÄNGERUNG	EXTENSIÓN PERNO		C
4	3014184	• •	COFANO	COVER	COFFRET	VERKLEIDUNG	ENVOLVENTE		
5	3003766	• •	VITE	SCREW	VIS	SCHRAUBE	TORNILLO		
6	3014068	• •	PULSANTE + VETRINO	BUTTON + VIEWING PORT	BOUTON + REGARD	TASTE + VERSCHLUßSTOP- FEN	BOTÓN + MIRILLA		
7	3013771	• •	PROTEZIONE MOTORE	GRID MOTOR	PROTECTION MOTEUR	SCHUTZGITTER MOTOR	PROTECCIÓN MOTOR		
8	3007589	• •	SPINA A 5 POLI	5 POLE PLUG	FICHE 5 POLES	STECKER 5 POLEN	CONECTOR MACHO DE 5 CON- TAC.		
9	3003891	• •	RACCORDO	CONNECTOR	MAMELON	NIPPEL	RACORD		
10	3003778	• •	ALBERINO	SHORT SHAFT	AXE	KLEINWELLE	ARBORILLO		
11	20019536	• •	MOTORE	MOTOR	MOTEUR	MOTOR	MOTOR		
12	3007434	• •	PRESA 5 POLI	5 POLE SOCKET	PRISE 5 POLES	5 - POLIGE STECKDOSE	CONECTOR HEMBRA DE 5 CON- TAC.		
13	3006948	• •	SPINA A 4 POLI	4 POLE PLUG	FICHE 4 POLES	STECKER 4 POLEN	CONECTOR MACHO DE 4 CON- TAC.		
14	3006949	• •	PRESA A 4 POLI	4 POLE SOCKET	PRISE 4 POLES	4 - POLIGE STECKDOSE	CONECTOR HEMBRA DE 4 CON- TAC.		
15	3006938	• •	PRESA A 7 POLI	7 POLE SOCKE	PRISE 7 POLES	7 - POLIGE STECKDOSE	CONECTOR HEMBRA DE 7 CON- TAC.		
16	3006937	• •	SPINA A 7 POLI	7 POLE PLUG	FICHE 7 POLES	STECKER 7 POLEN	CONECTOR MACHO DE 7 CON- TAC.		
17	3013202	• •	PRESA + SPINA 6 POLI	6 POLE PLUG + SOCKET	FICHE + PRISE 6 POLES	STECK.+ STECKERBUCHSE 6 POLEN	CONEC. MACHO-HEMBRA DE 6 CON- TAC.		
18	3014069	• •	MORSETTIERA	TERMINAL BOARD	BORNIER	STECKSOCKEL	REGLETA DE CONEXIÓN		
19	3013926	• •	DISPLAY	CAM SHAFT	PIVOT DE LA CAME	NOCKENWELLE	ARBORILLO EXCÉNTRICO		
20	3012841	• •	ZOCCOLO RELE'	RELAY BASE	RELAIS BORNIER	RELAIS SOCKEL	RELÉ + ZOCALO		
21	3012842	• •	RELÉ	RELAY	RELAIS	RELAIS	RELÉ		
22	3003959	• •	AVVIATORE	STARTER	DEMARREUR	ANLASSER	ARRANCADOR		C
23	3007444	• •	PRESSOSTATO ARIA	AIR PRESSURE SWITCH	PRESSOSTAT AIR	LUFTDRUCKWÄCHTER	PRESÓSTATO AIRE		A
24	3013927	• •	CAMMA ELETTRONICA	CAM ASSEMBLY	CAME COMPLETE	VERBUNDREGLER	EXCÉNTRICO COMPLETO		C
25	3013940	• •	GRUPPO CONNETTORI	CONNECTORS ASSEMBLY	GROUPE CONNECTEURS	VERBINDER-SYSTEM	GRUPO CONECTORS		
26	3006211	• •	FUSIBILE	FUSE	FUSIBLE	FEINSICHERUNG	FUSIBLE		
27	3012155	• •	FILTRO ANTIRADIODISTURBO	DEGLITCHER	FILTRE	ENTSTÖRER	FILTRO ANTI-INTERFERENCIA		C
28	3013928	• •	INTERRUTTORE	SWITCH	INTERRUPTEUR	SCHALTER	INTERUCTOR		
29	3013774	• •	TAPPO	PLUG	BOUCHON	PFROPFEN	TAPÓN		
30	3003848	• •	COLLEGAMENTO SONDA	PROBE LEAD	CONNEXION POUR SOND	VERBINDUNG FÜR SONDE	CABLE CONEXIÓN SONDA		A
31	3003794	• •	COLLEGAM. Elettrodo	H.T. LEAD	CONNEXION POUR ELEC- TRODE	VERBINDUNG FÜR ELEK- TRODE	CABLE CONEXIÓN ELEC- TRODO		A
32	3012038	•	TUBO ESTERNO	EXTERIOR TUBE	TUYAU EXTERIEUR	AUSSERER ROHR	TUBO EXTERNO		
32	3012039	•	TUBO ESTERNO	EXTERIOR TUBE	TUYAU EXTERIEUR	AUSSERER ROHR	TUBO EXTERNO		
33	3012193	•	SUPPORTO	SUPPORT	SUPPORT	HALTER	SOPORTE		
34	3003409	• •	CAVALLOTTO	U BOLT	CAVALIER	BÜGELBOLZEN	SOPORTE FIJACIÓN		
35	3012015	•	Elettrodo	ELECTRODE	ELECTRODE PORCELAINE	ELEKTRODE	ELECTRODO		A
35	3012016	•	Elettrodo	ELECTRODE	ELECTRODE PORCELAINE	ELEKTRODE	ELECTRODO		A
36	3012175	•	SONDA	PROBE	SONDE	FÜHLER	SONDA		A

N.	COD.	378900 378901 *	DESCRIZIONE	DESCRIPTION	DESCRIPTION	BESCHREIBUNG	DENOMINACION	MATRICOLA BRUCIATORE BURNER SERIAL NUMBER MATRICULE BRULEUR BRENNER KENN-NUMMER MATRICULA QUEMADORES	**
36	3012178	•	SONDA	PROBE	SONDE	FÜHLER	SONDA		A
37	3013778	•	TUBETTO	TUBE	TUYAU	RÖHRCHEN	TUBITO		
38	3013786	•	DISCO	DISC	DISQUE	SCHEIBE	DISCO		A
39	3013777	•	DISCO	DISC	DISQUE	SCHEIBE	DISCO		A
40	3013776	•	DISTRIBUTORE	GAS HEAD	DISTRIBUTEUR	GASVERTEILER	DISTRIBUIDOR		
41	3013775	•	GOMITO	ELBOW	COUDE	SCHLITTEN	CODO		
42	3013937	•	MOZZO						
43	3013938	•	DISCO	DISC	DISQUE	SCHEIBE	DISCO		A
44	3013936	•	SERVOMOTORE	SERVOMOTOR	SERVOMOTEUR	STELLMOTOR	SERVOMOTOR		B
45	3014186	•	SCUDO ANTERIORE	FRONT SHIELD	BOUCLIER AVANT	VORDERES SCHILD	ESCUDO ANTERIOR		
46	3013264	•	STAFFA	BRACKET	SUPPORT	HALTEBLECH	SOPORTE		
47	3013784	•	GUARNIZIONE	SEAL	RONDELLE	METALLDICHTUNG	JUNTA		C
48	3013785	•	STAFFA	BRACKET	SUPPORT	HALTEBLECH	SOPORTE		
49	3013939	•	INDICE	INDEX	REPERE	INDEXSTIFT	INDICE		
50	3012049	•	GRUPPO MISURAZIONE	TEST POINT	PRISE DE PRESSION	MESSNIPPEL	GRUPO TOMA DE PRESION		B
51	3012051	•	GRUPPO REGOLAZIONE	ADJUSTMENT ASSEMBLY	GROUPE OBTURATION	DRUCKREGULIERUNG	GRUPO REGULACIÓN		
51	3012052	•	GRUPPO REGOLAZIONE	ADJUSTMENT ASSEMBLY	GROUPE OBTURATION	DRUCKREGULIERUNG	GRUPO REGULACIÓN		
52	3003975	•	FRONTONE	FONT PIECE	FACADE	VORDERTEIL	SOPORTE QUEMADOR		
53	3003983	•	OTTURATORE	SHUTTER	OBTURATEUR	SCHIEBER	OBTURADOR		C
54	3003987	•	IMBUTO FIAMMA	END CONE	EMBOUT GUEULARD	FLAMMENROHR	TUBO EXTREMO		B
54	3003988	•	IMBUTO FIAMMA	END CONE	EMBOUT GUEULARD	FLAMMENROHR	TUBO EXTREMO		B
55	3003991	•	SCHERMO	FLANGE GASKET	ECRAN THERMIQUE	FLANSCHDICHTUNG	JUNTA AISLANTE		A
56	3003322	•	RACCORDO	CONNECTOR	MAMELON	NIPPEL	RACORD		
57	3012735	•	GUARNIZIONE	SEAL	RONDELLE	METALLDICHTUNG	JUNTA		B
58	3014187	•	MANICOTTO	MANIFOLD	MANCHON	GASANSCHLUSS	MANGUITO		
59	3003864	•	RACCORDO	CONNECTOR	MAMELON	NIPPEL	RACORD		
60	3003660	•	PRESSOSTATO GAS	GAS PRESSURE SWITCH	PRESSOSTAT GAZ	GASDRUCKWÄCHTER	PRESOSTATO DEL AIRE		
61	3006953	•	PRESA	SOCKET	PRISE	STECKDOSE	CONECTOR HEMBRA		B
62	3007088	•	GUARNIZIONE	SEAL	RONDELLE	METALLDICHTUNG	JUNTA		B
63	3005482	•	GUARNIZIONE	SEAL	RONDELLE	METALLDICHTUNG	JUNTA		B
64	3006803	•	FLANGIA E GOMITO	FLANGE AND ELBOW	BRIDE ET COUDE	ANSCHLUSSFLANSCHGAS	BRIDA Y CODO		
65	3003780	•	PASSACAVO	FAIRLEAD	PASSE-CABLE	KABELDURCHGANG	PASACABLES		
66	3014192	•	GUSCIO	HALF-SHELL	COUVERCLE	HAUBE	CÁSCARA		
67	3013931	•	SERVOMOTORE	SERVOMOTOR	SERVOMOTEUR	STELLMOTOR	SERVOMOTOR		B
68	3014080	•	STAFFA	BRACKET	SUPPORT	HALTEBLECH	SOPORTE		
69	3014194	•	MOZZO + QUADRANTE	HUB + GRADUATE SECTOR	MOYEU + SECTEUR GRADUE	NABE + SKALENSEGMENT	BUJE + MIRILLA		B
70	3014193	•	GRUPPO SERRANDA	AIR DAMPER ASSEMBLY	GROUPE VOLET AIR	LUFTKLAPPE	CONJUNTO REGISTRO AIRE		
71	3014185	•	BOCCA D'ASPIRAZIONE	AIR INTAKE	BOITIER D'ASPIRATION	ANSAUGÖFFNUNG	BOCA ASPIRACION		
72	3003830	•	FONOASSORBENTE	SOUND DAMPING	INSONORISANT	GERÄUSCHDÄMMUNG	AISLAMIENTO ACUSTICO		
73	3002480	•	TRASFORMATORE	TRANSFORMER	TRANSFORMATEUR	ZÜNDTRANSFORMATOR	TRANSFORMADOR		B

*

Versione Testa Lunga - Long Combustion Head Version - Version Tête Longue - Langer Brennkopf Ausführung - Versión alargado de tubo llama

**

RICAMBI CONSIGLIATI - ADVISED PARTS - RECHANGE CONSEIL - EMPFOHLENE ERSATZTEILE - RECAMBIOS ACONSEJADOS

A = Ricambi per dotazione minima - Spare parts for minimum fittings - Pièces détachées pour équipement minimum - Ersatzteile für minimale Ausstattung - Recambios para equipamiento mínimo

A+B = Ricambi per dotazione base di sicurezza - Spare parts for basic safety fittings - Pièces détachées pour équipement standard de sécurité - Ersatzteile für Sicherheitsgrundausrüstung - Recambios para equipamiento básico de seguridad

A+B+C = Ricambi per dotazione estesa di sicurezza - Spare parts for extended safety fittings - Pièces détachées pour équipement complet de sécurité - Ersatzteile für erweiterte Sicherheitsausrüstung - Recambios para equipamiento general de seguridad

RIELLO

RIELLO S.p.A.
I-37045 Legnago (VR)
Tel.: +39.0442.630111
[http:// www.riello.it](http://www.riello.it)
[http:// www.rielloburners.com](http://www.rielloburners.com)