

For the owner

Operating manual
ecoTEC



Gas wall boilers with condensing appliance technology

VU 466/4
VU 656/4

Contents

Appliance characteristics

Recommended accessories

Contents

Appliance characteristics	2
Recommended accessories	2
1 Notes on the documentation	3
1.1 Storage of documents	3
1.2 Symbols used	3
1.3 Validity of the instruction manual.....	3
1.4 Identification plate.....	3
1.5 CE label.....	3
2 Safety	4
2.1 Erection and adjustment.....	4
2.2 Action in case of emergency	4
2.3 Safety instructions	4
3 Instructions on operation	6
3.1 Vaillant warranty	6
3.2 Intended use.....	6
3.3 Requirements of the installation site	6
3.4 Care	6
3.5 Recycling and disposal	6
3.5.1 Appliance.....	6
3.5.2 Packaging.....	6
3.6 Energy saving tips	7
4 Operation	8
4.1 Overview of the operating elements	8
4.2 Measures prior to commissioning	10
4.2.1 Opening the isolating elements.....	10
4.2.2 Checking system pressure.....	10
4.3 Start-up.....	11
4.4 Hot water preparation.....	11
4.4.1 Setting the hot water temperature.....	11
4.4.2 Deactivating the storage tank mode	12
4.4.3 Drawing off the hot water	12
4.5 Setting for the heating mode	12
4.5.1 Setting the flow temperature (no controller connected).....	12
4.5.2 Setting the flow temperature (using a controller).....	13
4.5.3 Switching heating mode off (summer mode)....	13
4.5.4 Adjusting the room thermostat or weather compensator.....	13
4.6 Status displays (for maintenance and servicing by the engineer).....	13
4.7 Troubleshooting	14
4.7.1 Faults due to water deficiency	14
4.7.2 Faults in ignition.....	14
4.7.3 Faults in the air/flue gas routing.....	15
4.7.4 Feeding the device/heating system.....	15
4.8 Decommissioning	16
4.9 Frost protection	16
4.9.1 Frost prevention system.....	16
4.9.2 Frost protection through draining.....	16
4.10 Maintenance and customer service	17

Appliance characteristics

Vaillant ecoTEC units are compact wall-mounted gas condensing boilers.

Recommended accessories

Vaillant provides, for control of the ecoTEC, various controller versions for connection to the terminal rail or for plugging into the operating plate.

Controller
auroMATIC 560
timeSWITCH 130
timeSWITCH 140
VR 60 Mixing Module
VR 61 Mixing Module
VR 65
VR 68 Solar Module
VR 80 Remote Control
VR 81 Remote Control
VR 90/2 Remote Control
VRC 400
VRC 430
VRC 430f
VRC 630/2
vrnetDIALOG 830
vrnetDIALOG 840/2
vrnetDIALOG 860/2
VRT 230
VRT 340f
VRT 360
VRT 360f
VRT 392
VRT 392f
VRT 30
VRT 50

Table 0.1 Controller versions

Your expert technician company will help you select a suitable controller.

1 Notes on the documentation

The following information is intended to help you throughout the entire documentation.

Further documents apply in combination with this operating manual.

We accept no liability for any damage caused by non-observe these instructions.

Other applicable documents

For the owner of the system:

Short operator's manual No. 0020040000

For the heating engineer:

Installation and maintenance instructions No. 0020029172
or
No. 0020029173

Installation manual for flue pipe No. 0020046373

The manuals for any accessories and controllers used also apply.

The Benchmark gas boiler commissioning checklist (in the operating instruction manual) should be completed by the expert technician and/or by the technician present during the commissioning, and handed over to the operator of the installation.

If you have any questions, after reading through these instructions, considering the operation of the boiler, please contact your expert technician or the technical department of Vaillant.

1.1 Storage of documents

Please store this operating manual and other applicable documents where they are accessible at all times.

If you move out or sell the appliance, pass on the documents to the buyer.

1.2 Symbols used

Please observe the following when operating the unit:

Safety instructions in this operating instruction manual!



Danger!
Immediate risk of serious injury or death!



Danger!
Danger of burning or scalding!



Caution!
Potentially dangerous situation for the product and environment!



Note!
Useful information and instructions.

- Symbol for a necessary task

1.3 Validity of the instruction manual

This operating manual applies exclusively to units with the following article numbers:

- 0010004139
- 0010004140

For the article number of your unit please refer to the identification plate.

1.4 Identification plate

The identification plate of the Vaillant ecoTEC is mounted on the underside of the unit and on the rear of the electronics box at the factory.

1.5 CE label

CE labelling shows that the appliances comply with the basic requirements of the applicable directives as stated on the data badge.



Note!

Vaillant Ltd. supports the Benchmark Initiative. You will find the benchmark gas boiler commissioning checklist in the appendix to these installation instructions. It is very important that this document be filled out properly when installing, commissioning and handing-over to the operator of the installation.

2 Safety

2.1 Erection and adjustment

Installation and adjustment of the boiler and service, maintenance and repair work may only be carried out by expert technicians in accordance with regulations introduced in 1998 governing the safety of gas installations (installation and use). (In Great Britain "CORGI". This means that the work carried out by registered installation companies must always be to a safe and satisfactory standard.) If the boiler is mounted in a cabinet-type enclosure the ventilation openings must not be obstructed and the enclosure must not be used for storage purposes.

2.2 Action in case of emergency



Danger!

If you smell gas!

Risk of poisoning and explosion due to a malfunction!

Procedure in case of gas smell in buildings

- Open doors and windows wide, facilitate through movement of air, stay out of rooms where gas odour is present!
- Avoid naked flames, do not smoke, do not use pocket lighters!
- Do not use electric switches, plugs, bells, telephones and other communication systems in the building!
- Close gas meter isolator device or main isolator device!
- Close gas isolator cock (1, Fig. 2.1) on unit!
- Warn other building residents, but avoid ringing door-bells!
- Vacate building!
- Inform the gas supply company stand-by service from a telephone outside the building!
- If a gas leak is audible, leave the building immediately, prevent others from entering the building and notify the police and fire brigade from outside the building!

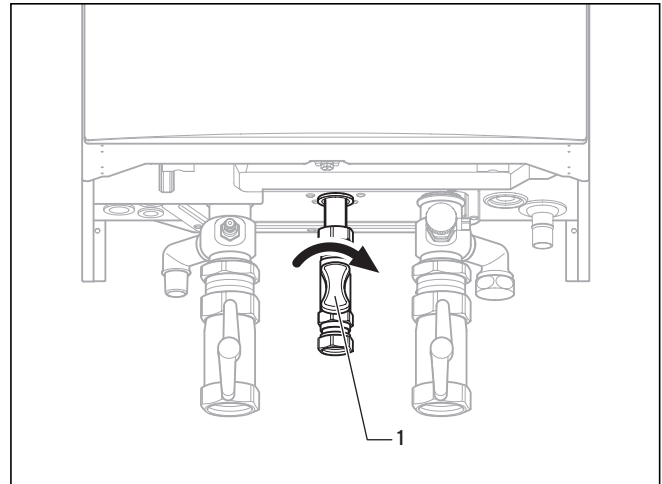

Fig. 2.1 Closing the gas isolator cock

2.3 Safety instructions

Always observe the following safety instructions and regulations.



Danger!

Inflammable mixtures of gas and air may explode!

Do not use or store explosives or highly flammable substances, such as petrol or paint, in the same room as the unit.



Danger!

Risk of poisoning and explosion due to a malfunction!

Never put the safety devices out of operation or tamper with them so as to impair their function.

Therefore, do not attempt any modifications:

- to the unit,
- around the unit,
- to the gas, air, water and electricity supply pipes,
- to the expansion relief valve and drain line for the heating water,
- to the flue gas pipes.

This also applies to alterations to structural elements in the vicinity of the appliance which might affect its operational safety.

Example:

- If you require cabinet-type cladding for your unit, consult your recognised expert technician company. Under no circumstances must you enclose your device arbitrarily. Enclosing the appliance in a cabinet requires observance of special design instructions.

For alterations to the appliance or to its environment, you must refer to the suitably qualified heating engineer which is responsible for it.

 **Caution!**
Inappropriate alterations can cause damage!
Under no circumstances should you attempt to make alterations to the gas wall-mounted boiler or other parts of the system.
Never try to carry out maintenance work or repairs on the appliance yourself.

- Do not damage or remove seals on components. Only a suitably qualified heating engineer or our customer service may remove sealed components.

 **Danger!**
Risk of scalding!
The water coming out of the tap can be very hot.

 **Caution!**
Risk of damage!
Do not use sprays, solvents, chlorinated cleaning agents, paint, adhesives or similar substances in the vicinity of the appliance. These substances can cause corrosion, even in the flue system.

Installation and setting

 **Caution!**
Installation of the unit may only be undertaken by a recognised specialised technician in accordance with "Gas Safety (Installation and Use) Regulations 1998".
In IE the installation must comply with the current Version of I.S.813 'Domestic Gas Installations' (gas installations in private households) and the current Building Regulations. The current ETCI Regulations for the installation of electrical equipment must also be observed.

 **Caution!**
The unit may only be operated continuously with its cladding properly closed! Otherwise, under unfavourable conditions, it can result in material damage or even injury or death.

Filling pressure of the heating system

Regularly check the filling pressure of the heating installation, see Chapter 4.7.4.

Emergency power supply

Your heating engineer connected your gas wall-mounted heating device to the mains supply during installation.

If you wish to keep the unit ready for operation using an emergency generating set in the event of a power failure, the technical specification of the unit (frequency, voltage, earthing) must match the power mains, and must correspond at least to the power consumption of your unit. Contact your expert technician company for advice.

Frost protection

If you are going to be away during a cold period, make sure the heating system remains in operation and that the rooms are sufficiently heated.

 **Caution!**
Risk of damage!
If there is a power cut or if the room temperature is set too low in individual rooms it can not be ruled out that sections of the heating system are damaged by frost.
Always observe the information on frost protection provided in Chapter 4.9.

3 Instructions on operation

3 Instructions on operation

3.1 Vaillant warranty

Vaillant provide a full parts and labour warranty for this appliance.

The appliance must be installed by a suitably competent person in accordance with the Gas Safety (Installation and Use) Regulations 1998, and the manufacturer's instructions. In the UK 'CORGI' registered installers undertake the work in compliance with safe and satisfactory standards. All unvented domestic hot water cylinders must be installed by a competent person to the prevailing building regulations at the time of installation. (G3) Terms and conditions apply to the warranty, details of which can be found on the warranty registration card included with this appliance.

Failure to install and commission this appliance in compliance with the manufacturer's instructions may invalidate the warranty (this does not affect the customer's statutory rights).

3.2 Intended use

The Vaillant atmo ecoTEC wall boilers are state-of-the-art appliances which have been constructed in accordance with recognised safety regulations. Nevertheless, there is still a risk of injury or death to the user or others or of damage to the device and other property in the event of improper use or use for which it is not intended.

This unit is not intended for use by persons (including children) having limited physical, sensory or mental capacities or who have inadequate experience and/or knowledge, unless supervised by a person responsible for their safety or who has been given instructions from them as to how to operate the unit. Children must be watched to ensure that they do not play with the unit. The units are intended as heat generators for closed hot-water central heating installations and for central hot water preparation. Any other or additional use is considered to be improper. The manufacturer or supplier is not liable for any resulting damage. The user alone bears the risk.

Intended use includes the observance of the operating and installation manual and all other applicable documents, as well as adherence to the maintenance and inspection conditions.



Caution!

Any improper use is forbidden.

3.3 Requirements of the installation site

The Vaillant ecoTEC gas wall boilers are installed on the wall so that condensation can be diverted and so that the flue system pipes can be laid.

They can be installed in basements, storage rooms, utility rooms or living areas. Ask your heating engineer which national regulations must be observed.



Note!

It is not necessary to keep a clearance between the appliance and combustible materials or components, since at the rated heating power of the appliance the temperature at the surface of the housing is always lower than the maximum allowed temperature of 85 °C.

3.4 Care

- Clean the cladding of your unit with a damp cloth and a little soap.



Caution!

Risk of damage

Do not use scouring or cleaning agents which might damage the cladding, fittings or controls. Do not use sprays, solvents or cleaning agents containing chlorine.

3.5 Recycling and disposal

Both your Vaillant ecoTEC gas wall boiler and its packaging consist mainly of recyclable raw materials.

3.5.1 Appliance

Do not dispose of your Vaillant ecoTEC gas-fired wall-mounted unit or any of its accessories in the household waste. Make sure the old appliance and any accessories are disposed of properly.

3.5.2 Packaging

Leave the disposal of the transport packaging to the qualified servicing company which installed the appliance.



Note!

Please observe the applicable national legal regulations.

3.6 Energy saving tips

Installing a weather compensator

Weather-compensators regulate the heating feed temperature with reference to the outside temperature. No more heat is generated than is currently required. The designated heating flow temperature for the corresponding outside temperature must be set on the weather compensator. This setting must not be greater than required by the heating installation design. The correct setting is normally undertaken by the heating engineer. The required heating and set-back phases (e.g. at night) are automatically switched on/off using integrated timer programs. Weather compensators combined with thermostat valves are the most economical form of heating regulation.

Reducing the heating system

Reducing the room temperature at night and in your absence. This is most easily and reliably achieved using controllers with timer programs that can be selected according to individual requirements. At such times, set the room temperature approx. 5 °C lower than during full heating times. Reduction of more than 5 °C brings no additional energy saving, because then increased heating capacities would be needed for the next full heating period. Only for longer absences, e.g. holidays, is it worthwhile to further lower the temperatures. However, in winter, make sure that there is adequate frost protection.

Room temperature

Set the room temperature only as high as would be enough for your comfort level. An extra degree would mean increased energy consumption of about 6%. Adjust the room temperature according to the use of the specific room. For example, normally, bedrooms or seldom used rooms are heated to 20 °C.

Setting the operating mode

In warmer seasons, when the apartment needs no heating, turn the heating to summer mode. The heating mode is then shut off, however, the device or the plant remains ready for operation for water heating.

Uniform heating

Often, in an apartment with central heating, only one room is heated. Adjacent rooms are also heated without regulation by the enclosing surfaces of the room, i.e. walls, doors, windows, roofs, floors, which means that an unwanted loss of thermal energy occurs. In these kind of operating conditions the power of the radiator in this heated room is obviously insufficient. Consequently, the room cannot be heated adequately and an uncomfortable feeling of coolness prevails (the same effect is produced when doors between heated and unheated or partially heated rooms remain open). This is incorrect saving: The heating is in operation and still the room temperature is not comfortably warm.

Greater heating comfort and a more practical operating mode is achieved when all rooms in an apartment are heated uniformly and in accordance to their usage. The building structure can also suffer if components of the building are unheated or only inadequately heated.

Thermostat valves and room thermostat

Nowadays, all radiators should be fitted with thermostatic valves as a matter of course. They maintain the set room temperature precisely. You can adjust the room temperature to suit your individual requirements and ensure effective operation of your heating installation using thermostatic valves in combination with a room thermostat (or weather compensator). All the radiator valves should be fully opened in the room where the room thermostat is located, as otherwise the two control systems will influence one another and the regulation quality will be adversely affected. Incidentally, the following user behaviour is frequently observed: As soon as the room becomes too hot the user turns the thermostatic valve off (or specifies a lower temperature at the room thermostat). If after a period of time the user feels cold and opens the thermostatic valve again. This procedure is not only inconvenient, it is also completely unnecessary as a correctly functioning thermostatic valve does this automatically: If the room temperature rises above the value set on the sensor head, the thermostat valve shuts off automatically, when the temperature drops below the defined value, it opens again.

Do not cover regulators

Do not cover your regulators with furniture, drapes or similar objects. The room air must circulate unhindered. Covered thermostat valves can be equipped with remote sensors and thus still work.

Appropriate hot water temperature

The hot water should only be heated to the required temperature. Any further heating results in unnecessary power consumption and hot water temperatures of more than 60 °C also lead to increased lime scale reduction.

Energy-conscious use of water

Energy-conscious use of water can also reduce costs considerably. e. g. showering instead of bathing: whereas about 150 litres of water are required for a bath, a modern shower equipped with water saving fittings uses around a third of this quantity. By the way: a dripping water tap wastes up to 2000 litres of water and a leaking toilet flush up to 4000 litres of water each year. A new seal costs very little by comparison.

Run circulation pumps only if needed

Circulation pumps facilitate the continuous circulation of hot water through the piping system which means that hot water is immediately available, also at more distant draw-off points.

3 Instructions on operation

4 Operation

These pumps undoubtedly enhance the convenience of the hot water generation process. But they also need power. And circulating hot water that is not used cools off when passing through pipes and then needs to be reheated. Therefore, circulation pumps are to be operated only when hot water is actually needed for the household. Individual timer programs can be defined using switching clocks, which are already installed or can be retrofitted in most circulation pumps. Weather compensators often have ancillary functions for controlling circulation pump timings. Consult your heating engineer. Another option is to turn on the circulation only for concrete needs for a specific period of time by using a button or switch installed near a frequently used water plug. A corresponding button can be connected to the Vaillant ecoTEC electronics.

Ventilating residential spaces

During the heating period, open windows only for ventilation and not for temperature regulation. A brief impact-ventilation is more effective and energy-saving than windows that are kept open for a long time. We recommend that the windows be opened fully for a short period. When ventilating the room, close all thermostatic valves in the room or specify the minimum temperature at the room thermostat (if installed). These measures guarantee a sufficient exchange of air and avoid unnecessary cooling and loss of energy (e.g. due to unwanted activation of the heating system during ventilation).

4 Operation

4.1 Overview of the operating elements

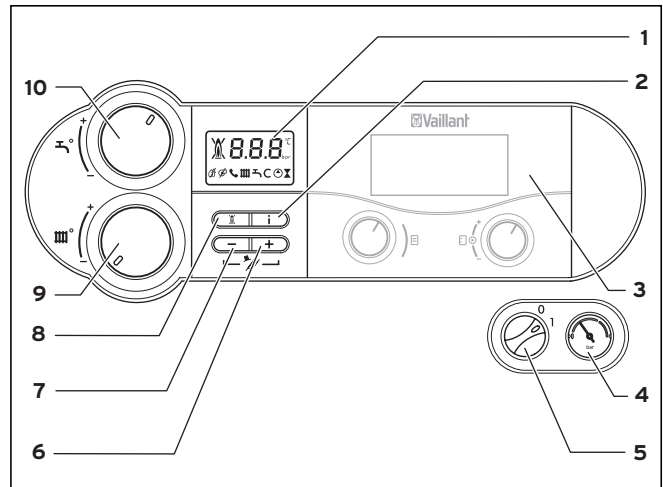

Fig. 4.1 Operating elements ecoTEC

To open the front panel, hold the recess and pull it down. You can now see the controls with the following functions (cp. Fig. 4.1):

- 1 Display indicating the current heating flow temperature, the filling pressure of the heating system, the operating mode and other additional information
- 2 Button "i" for calling up information
- 3 Controller (accessory)
- 4 Pressure gauge showing the filling or operating pressure in the heating system
- 5 Button for switching the unit on and off.
- 6 "+" button for navigating forwards through the display view (used by expert technician to specify settings and for troubleshooting) or displaying the storage temperature (VU with cylinder sensor)
- 7 "-" button for navigating backwards through the display view (used by expert technician to specify settings and for troubleshooting) and for displaying the filling pressure of the heating system
- 8 "**Fault resolution**" button for resetting the system in the case of specific faults
- 9 Rotary knob for setting the heating feed temperature

- 10 Rotary knob for specifying the storage temperature (in conjunction with VU units with connected domestic hot water cylinder VIH)

This operating mode **cannot** be ended:
 - by pushing the button (8) "Fault reset"
 or
 - by switching the unit on or off.

Digital Information and Analysis System (DIA)

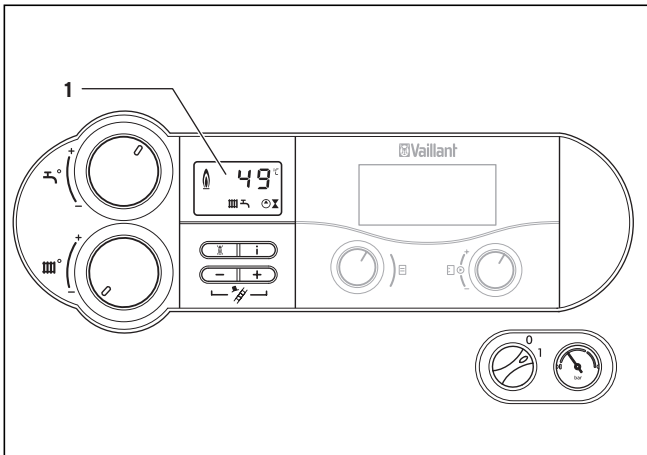

Fig. 4.2 Display ecoTEC

A Digital Information and Analysis System is fitted in ecoTEC units. This system provides information on the operating status of your appliance and helps you deal with problems. During normal operation, the display (1) shows the current heating feed temperature (in this example 45 °C). In the event of a fault, an error code appears instead of the temperature. You can also see the following information from the symbols displayed:

- 1 The current heating flow temperature, the heating system filling pressure or a status or error code

Flue problem

Flue problem

Only in combination with the vrnetDIALOG:
 As long as this symbol appears in the display, the heating feed temperature and hot water outlet temperature are specified by vrnetDIALOG (accessory), which means the unit operates at temperatures other than those set using the rotary knobs (9) and (10).
 This operating mode can only be ended:
 - via vrnetDIALOG or
 - by altering the temperature setting at the rotary knobs (9) or (10) by more than ± 5 K.

Hot water preparation active permanently on: Operating mode heating flashes: Burner lockout time active

Hot water preparation active permanently on: recharging operating mode on standby
 Flashing: Hot water storage tank is being heated, burner on

Internal pump is in operation

Actuating internal gas valve

Flame with cross: Fault during burner operation; Unit is switched off

Flame without cross: Burner operation normal

4 Operation

4.2 Measures prior to commissioning

4.2.1 Opening the isolating elements

Note!

The isolator devices are not included in the scope of delivery for your unit. They are fitted by your heating engineer on site. He must explain to you the position and handling of these components.

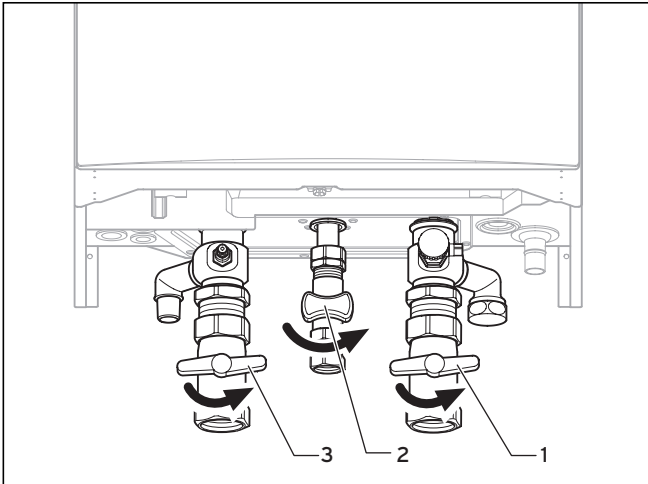

Fig. 4.3 Open isolator devices (maintenance cocks, for example)

- Open the gas isolator cock (2) by pressing it in and turning it anticlockwise until it reaches the limit stop.
- Check that the supply (3) and return (1) maintenance cocks are open. This is the case when the handles of the maintenance cocks are parallel to the direction of the piping.

4.2.2 Checking system pressure

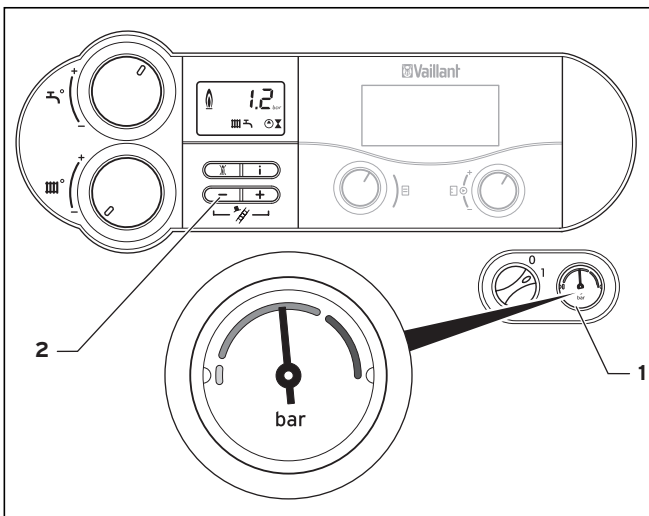

Fig. 4.4 Check the filling pressure of the heating system

- Check the filling pressure of the system using the pressure gauge (1) before putting it into operation. For the heating installation to operate correctly the indicator for the pressure gauge (1) must be in the upper half of the dark grey area when the system is cold (see Fig. 4.4). This corresponds to a filling pressure between 1.0 and 2.0 bar. If the indicator is in the area with the light grey background, the system must be topped up with water before starting up (see Chapter 4.7.4).

Note!

The ecoTEC unit is equipped with a pressure gauge and a digital pressure indicator. The pressure gauge allows you to quickly check that the filling pressure is within the target range when the appliance is turned off. When the unit is in operation, you can have the exact pressure shown in the display. Activate the pressure display by pressing the "-" button (2). After 5 seconds the display returns to the feed temperature. You can also switch continuously between the temperature and pressure in the display by keeping the "-" button pressed for roughly 5 seconds.

Note!

To avoid running the system with too little water and thus prevent damage, your appliance has a pressure sensor. This signals the low pressure level if the level falls below 0.6 bar by the water pressure value in the display flashing. If the pressure falls below 0.3 bar the unit switches off. The error message F.22 appears in the display. Fill the system up with water before you start up the appliance again.

If the heating system extends over several floors, the system may require a higher filling pressure. Ask your engineer for details.

4.3 Start-up

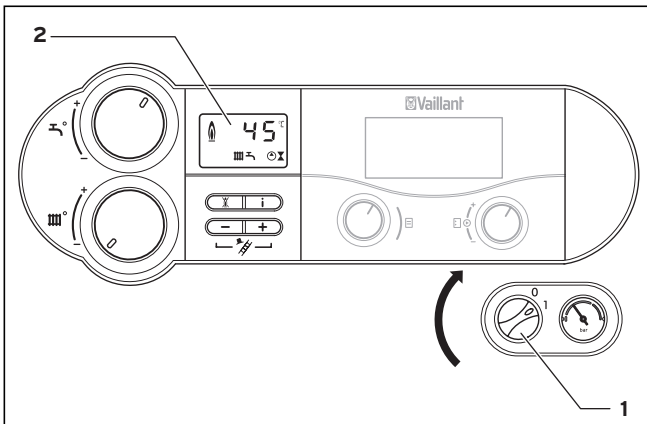

Fig. 4.5 Switching the appliance on

- Use the main switch (1) to switch the appliance on and off:
1: "ON"
0: "OFF"

When you switch the unit on the display (2) shows the current heating feed temperature.

To customise the settings in the unit, read Chapters 4.4 and 4.5 where the options for the hot water generation and heating mode settings are described.



Caution!

Risk of damage!

The frost protection and monitoring systems are only active if the main switch of the unit is in the "I" position and the unit is connected to the power mains.

To ensure that these protection devices remain active, switch your gas wall-mounted boiler on and off using the controller (see the corresponding operating manual).

Chapter 4.8 describes how you can fully shutdown your gas-fired wall-mounted boiler.

4.4 Hot water preparation

To generate hot water in conjunction with the VU unit type a VIH-type domestic hot water cylinder must be connected to the boiler.

4.4.1 Setting the hot water temperature

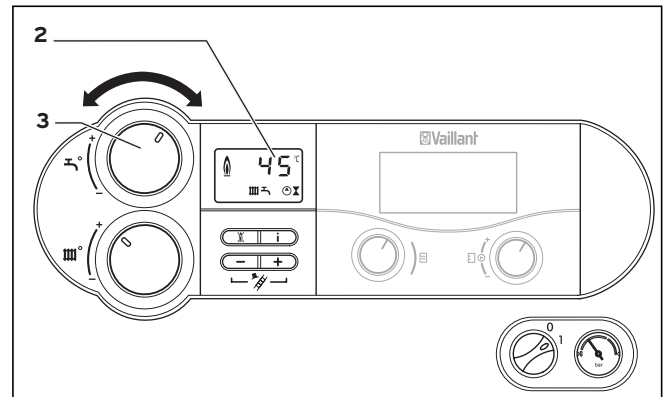

Fig. 4.6 Setting the water temperature

- Switch on the unit as described in Chapter 4.3.
- Specify the storage temperature you require using the corresponding rotary knob (3). In doing this:

- left-hand limit stop, **approx. 15 °C**
- right-hand limit stop, **max. 70 °C**

When you set the desired temperature, the respective nominal value is shown on the display (2).

This display disappears after 3 seconds and is replaced by the standard display (current heating feed temperature or water pressure in the system (optional)).



Danger!

Health danger from formation of Legionella!
If the unit is used for post-heating within a solar-supported drinking water heating installation, set the hot water outlet temperature to at least 60 °C via the rotary knob (3).



Caution!

Risk of calcification!

If the water hardness is more than 3.57 mol/m³ (20 °dH), do not turn the rotary knob (3) beyond the middle position.



Note!

If your controller is connected to a dual-cable eBUS line, specify the highest possible hot water temperature using the corresponding rotary knob. Specify the set target temperature for your cylinder at the controller.

4 Operation

4.4.2 Deactivating the storage tank mode

In VU units connected to domestic hot water cylinders you can deactivate the hot water generation or recharging operation whilst keeping the heating system in operation.

- Turn the rotary knob for setting the hot water temperature all the way to the left. Only the frost protection function for the cylinder remains active.

4.4.3 Drawing off the hot water

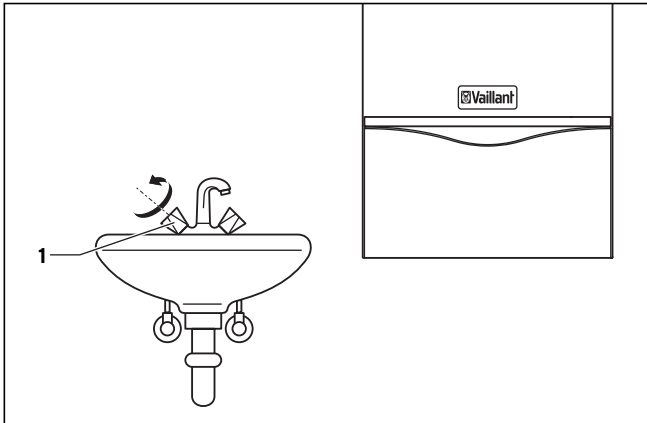

4.7 Drawing off hot water

Hot water is drawn from the connected cylinder when a hot water tap (1) is opened at a draw-off point (washbasin, shower, bathtub, etc.)

If the storage temperature falls below the set temperature, the VU unit starts up automatically and reheats the cylinder. The VU unit switches off automatically when the cylinder reaches the set target temperature. The pump continues to run for a short while.

4.5 Setting for the heating mode

4.5.1 Setting the flow temperature (no controller connected)

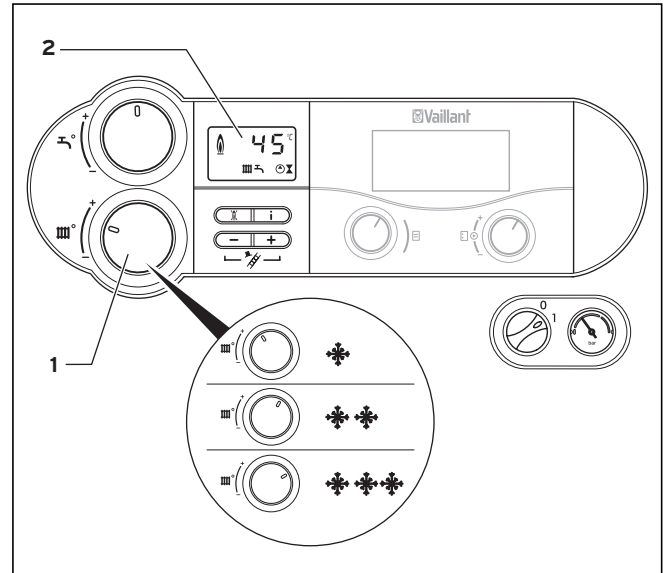

Fig. 4.8 Setting the flow temperature without a controller

If there is no external controller, set the flow temperature using the knob (1) according to the outside temperature. We recommend the following settings:

- **Left position** (but not all the way) in spring and autumn: Outside temperature approx. 10 to 20 °C
- **Mid-position setting** in reasonably cold weather: Outside temperature approx. 0 to 10 °C
- **Right position** in very cold weather: Outside temperature approx. 0 to -15 °C

When you adjust the temperature, the value specified is shown in the display (2). This display disappears after 3 seconds and is replaced by the standard display (current heating feed temperature or water pressure in the system (optional)).

The settings at the rotary knob (1) are normally infinitely variable up to a feed temperature of 75 °C. However, if higher temperatures can be set on your appliance, have your engineer make adjustments so that you can operate the heating system at higher flow temperatures.

4.5.2 Setting the flow temperature (using a controller)

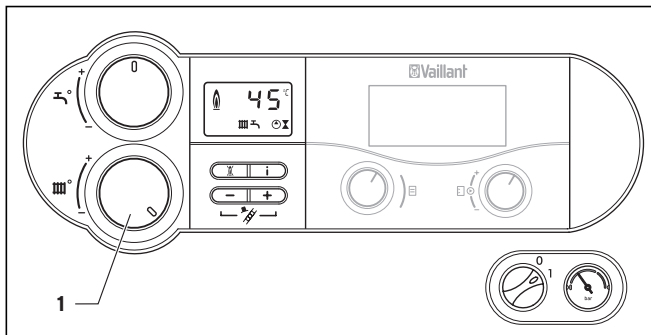

Fig. 4.9 Setting the flow temperature using a controller

If your boiler has a room thermostat or weather compensator, you must make the following settings:

- Turn the rotary knob (1) for the heating feed temperature all the way to the right.

The flow temperature is automatically adjusted by the controller (for information, see its operating manual).

4.5.3 Switching heating mode off (summer mode)

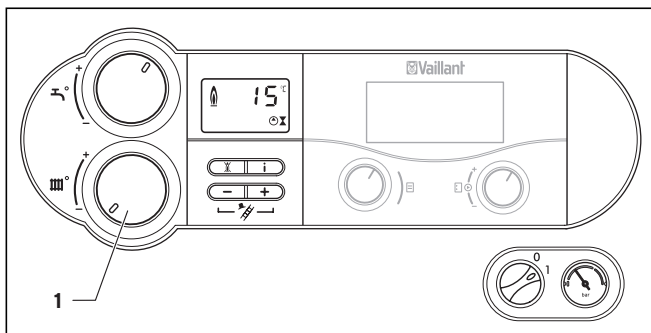

Fig. 4.10 Switching off heating (summer operation)

You can switch off the heating in summer without switching off the hot water supply.

- Turn the rotary knob (1) for setting the heating feed temperature all the way to the left.

4.5.4 Adjusting the room thermostat or weather compensator

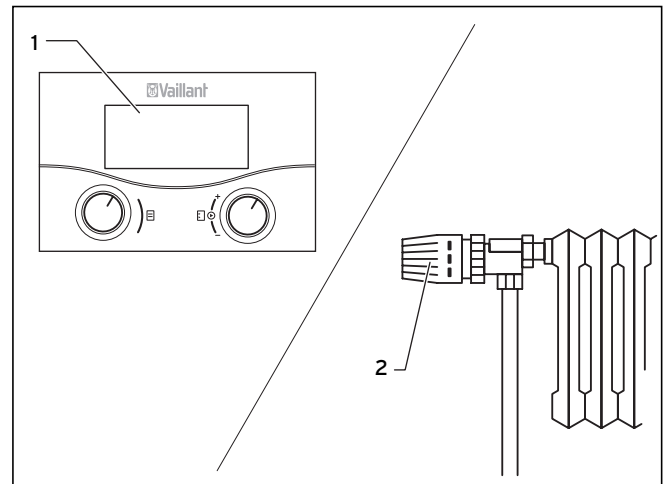

Fig. 4.11 Setting a room thermostat or weather compensator

- Set the room thermostats (1), weather compensators or radiator thermostat valves (2) as specified in the operating manuals for these accessories.

4.6 Status displays (for maintenance and servicing by the engineer)

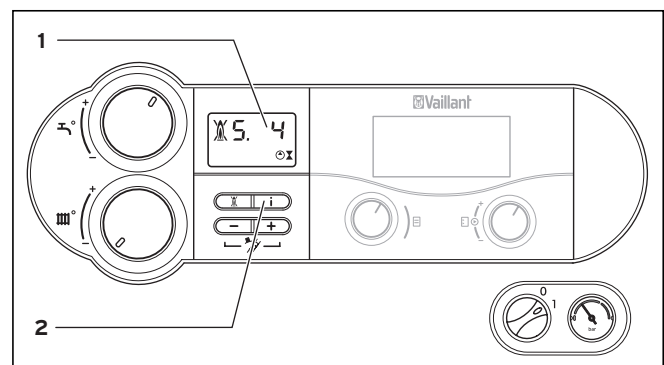

Fig. 4.12 Status displays

The status displays provide information on the operating status of the unit.

- Press the "i" button (2) to activate the status displays.

The display (1) then shows the individual status codes, e.g. "S. 4" for burner operation. The table below explains the most important status codes.

In switching phases, for example on starting up again after the flame was extinguished, the status message "S." briefly appears.

- Press the "i" button (2) again to switch the display back to normal mode.

4 Operation

Display	Meaning
	Displays during heating operation
S. 0	Heating, no heat demand
S. 1	Heating mode, fan start-up
S. 2	Heating mode, pump flow
S. 3	Heating mode, ignition
S. 4	Heating mode, burner on
S. 6	Heating mode, fan overrun
S. 7	Heating mode, pump overrun
S. 8	Heating, remaining cut-off time xx min
S.31	no heat demand, summer operating mode
S.34	Heating mode, frost protection
	Displays in storage tank charging
S. 20	Hot water requirement
S.22	Hot water handling, pump flow
S.24	Hot water operation burner on
	Service message (appears as necessary and replaces the normal status text)
S.85	Service message, quantity of circulation water

Table 4.1 Status codes and what they mean (selection)

4.7 Troubleshooting

If you have problems operating your gas-fired wall-mounted boiler, you can check the following points yourself:

No hot water, heating stays cold; Appliance does not start:

- Are the gas isolator cocks for the building supply and the appliance open (see Chapter 4.2.1)?
- Is the power supply switched on?
- Is the main switch on the gas-fired wall-mounted boiler switched on (see Chapter 4.3)?
- Is the rotary knob for setting the feed temperature on the gas-fired wall-mounted boiler not turned to the far left, i.e. frost protection active (see Chapter 4.4)?
- Is the filling pressure of the heating installation sufficient (see Chapter 4.2.2)?
- Is there air in the heating installation?
- Is there a fault in the ignition process (see Chapter 4.7.2)?

Hot water operation, no problem; Heating does not start:

- Has the external controller (e.g. calorMATIC controller) signalled a heat requirement (see Chapter 4.5.4)?



Caution!

Inappropriate alterations can cause damage!
If your gas-fired wall-mounted boiler is still not working properly after you have checked the above points, consult a recognised expert technician company or Vaillant Service Solutions for advice.

4.7.1 Faults due to water deficiency

The device switches to "Fault" if the filling pressure in the heating system is too low. This malfunction is indicated by the fault codes "F.22" (dry fire) or "F.23" or "F.24" (water shortage). You can only start up the appliance again when the heating system is sufficiently filled with water.

If the pressure drops frequently the reason for the loss of hot water must be identified and eliminated by a recognised expert technician company.

4.7.2 Faults in ignition

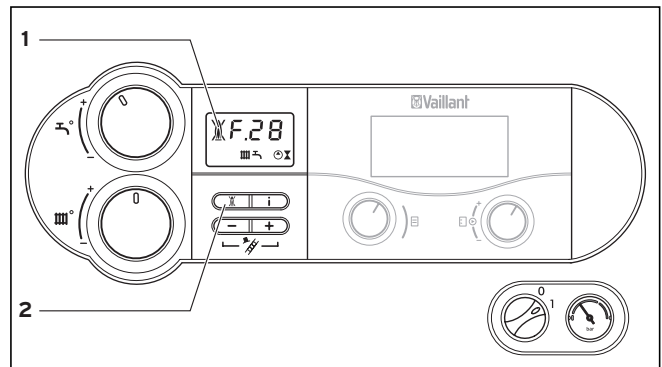

Fig. 4.13 Troubleshooting

If the burner fails to ignite after five attempts, the unit will not operate and switches to "Fault". This is indicated by the error code "F.28" or "F.29" on the display. In addition, the display shows a flame symbol with a cross through it (1).



Automatic ignition can only take place after you manually reset the fault.

- In this case, press the fault suppression button (2) and hold it down for roughly one second to reset the fault.

Caution!
Inappropriate alterations can cause damage!
If your gas-fired boiler still does not start after the third attempt to suppress the fault, consult a recognised expert technician company or Vaillant Service Solutions for advice.

4.7.3 Faults in the air/flue gas routing

The appliances are fitted with a blower. If the blower does not work properly, the appliance will switch itself off.

The  and  symbols as well as the error message "F.32" appear in the display.

Caution!
Inappropriate alterations can cause damage!
If this error message appears consult a recognised expert technician company for advice.

4.7.4 Feeding the device/heating system

The filling pressure must be between 1.0 and 2.0 bar when the system is cold in order for the heating installation to operate properly (see Chapter 4.2.2). If the pressure is less, top up the system with water.

If the heating system extends over several floors, the system may require a higher filling pressure. Ask your engineer for details.

Caution!
Risk of damage to the gas-fired wall-mounted boiler!
Use only clean tap-water to fill the heating system.
The addition of chemicals such as e.g. frost and corrosion prevention materials (inhibitors) is not permitted.
Otherwise it could result in damage to seals and diaphragms as well as noises during the heating operation.
Vaillant assumes no liability for this and such consequential damages.

To fill up and to re-fill the heating system, you can normally use tap water. However in exceptions, the water quality might not be suitable for filling in the heating system (heavily corrosive or extremely calciferous water). In these kind of situations contact your recognised expert technician company.

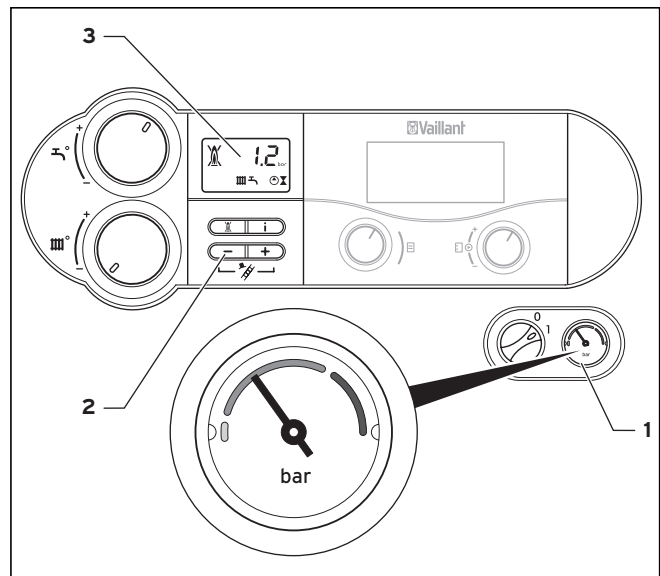

Fig. 4.14 Filling the heating installation

Proceed as follows to fill the system:

- Open all radiator valves (thermostat valves) of the system.
- Connect the filling tap of the installation to a cold water draw-off valve with a hose (your heating engineer should have shown you the filling fittings and explained the filling and draining of the system).
- Open the filling cock slowly.
- Slowly turn the draw-off valve on and top up the system with water until the required pressure is shown at the pressure gauge (1) or in the display (3).

You can call up the precise value for the pressure in the display.

- Activate the pressure display by pressing the "-" button (2). After 5 seconds the display returns to the feed temperature. You can also switch between the continuous display of temperature or pressure by keeping the "-" button pressed for roughly 5 seconds.
- Turn the tap off.
- Bleed all the radiators.
- Then check the installation pressure at the pressure gauge or display and add more water if necessary.
- Close the filling cock and remove the filling hose.

4 Operation

4.8 Decommissioning

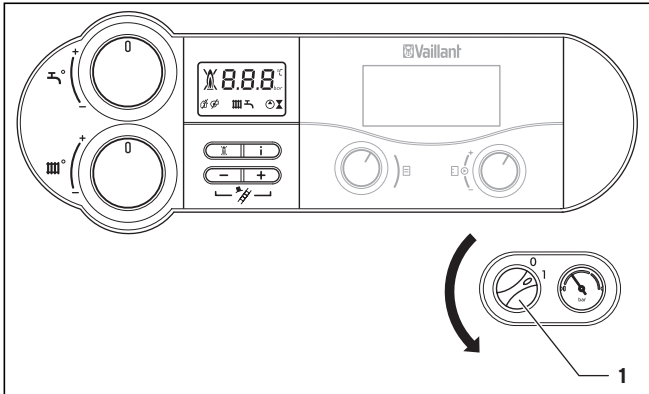

Fig. 4.15 Switching off the appliance

- To shut down your gas wall-mounted boiler, turn the main switch (1) to the position "0".



Caution!

The frost protection and monitoring systems are only active if the main switch of the unit is in the "I" position and the unit is connected to the power mains.

To ensure that these protection devices remain active, switch your gas wall-mounted boiler on and off in normal mode using the controller (see the corresponding operating manual).



Note!

For longer periods of shut-down (e.g. holiday periods), the gas stop-cock and the cold water stop-cock should be switched off. For relevant information on frost protection refer to Chapter 4.9.



Note!

The isolator devices are not included in the scope of delivery for your unit. They are fitted by your heating engineer on site. He must explain to you the position and handling of these components.

4.9 Frost protection

The heating system and water pipes are sufficiently protected against frost if the heating system remains on and the rooms are sufficiently heated while you are away.



Caution!

The frost protection and monitoring systems are only active if the main switch of the unit is in the "I" position and the unit is connected to the power mains.



Caution!

Addition of frost preventative medium to the heating water is not permitted. This could affect seals and diaphragms and cause noise when the system is in heating mode. Vaillant assumes no liability for this and such consequential damages.

4.9.1 Frost prevention system

The gas wall-mounted boiler is equipped with a frost protection system:

If the heating feed temperature falls below 5°C when the main switch is on, the unit comes into operation and heats the heat generation circuit to approx. 30°C.



Caution!

Danger of freezing of parts installed within the overall system!

The frost protection system can not guarantee flow through the entire heating system.

4.9.2 Frost protection through draining

Another way to protect the heating system and the appliance from frost is to drain them. You must ensure that the system and the appliance are completely drained.

All cold and hot water conductors in the house and in the appliance must be drained too.

Contact your heating engineer.

4.10 Maintenance and customer service

To ensure that the unit is always ready for operation, is operationally safe and reliable and has a long working life, inspection/maintenance must be carried out **annually** by an expert technician or by Vaillant.

Further information can be obtained from Vaillant Service Solutions . (0870 6060 777).



Danger!

Danger of property damage and personal injury from improper handling!

Never attempt to perform maintenance or repairs on the gas wall-mounted boiler yourself. Assign an approved qualified servicing company with this work. We recommend making a maintenance agreement.

The operational reliability of the device can be impaired, resulting in damage to property or personal injury, if maintenance work is not carried out.

Regular maintenance maximises the efficiency of your gas-fired wall-mounted boiler and therefore makes it more economical to run.

Vaillant Ltd

Vaillant House ■ Medway City Estate ■ Trident Close ■ Rochester ■ Kent ME2 4EZ
Telephone 01634 292300 ■ Fax 01634 290166 ■ www.vaillant.co.uk ■ info@vaillant.co.uk

0020052777_00 GB 10 2007