

For the competent person

Installation and maintenance instructions

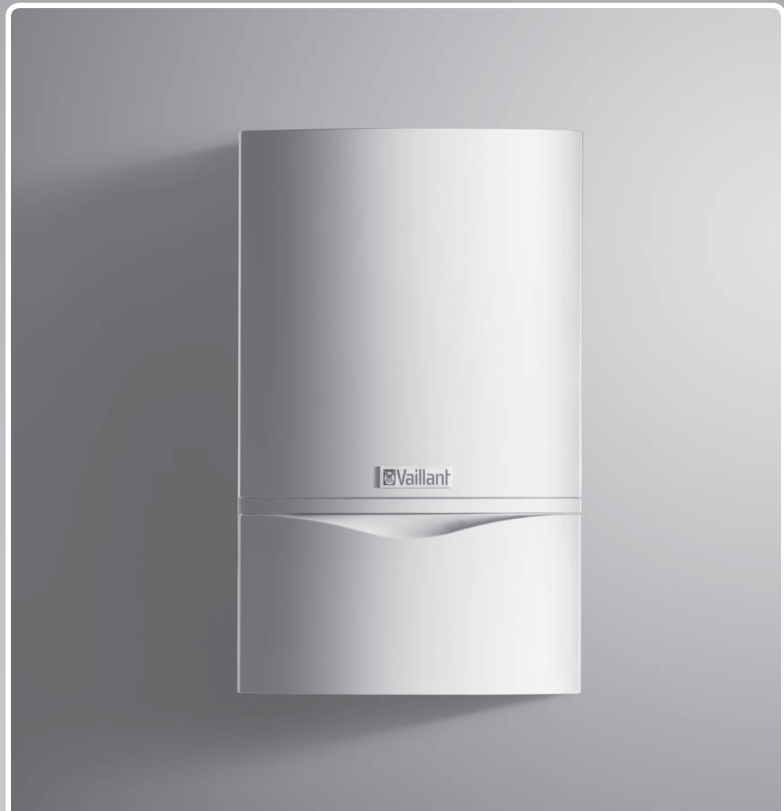

ecoTEC plus

VU GB 656/4-5 A

GB, IE

Publisher/Manufacturer

Vaillant GmbH

Berghauser Str. 40 ■ D-42859 Remscheid
Tel. +49 21 91 18-0 ■ Fax +49 21 91 18-2810
info@vaillant.de ■ www.vaillant.de



Contents

Contents

1	Safety	4	7	Adapting the unit to the heating installation	23
1.1	Action-related warnings	4	7.1	Calling up diagnostics codes	23
1.2	Intended use	4	7.2	Calling up the installer level (second diagnostics level)	23
1.3	General safety information	4	7.3	Setting the heating partial load	23
1.4	Regulations (directives, laws, standards).....	6	7.4	Setting the pump overrun and pump operating mode.....	23
2	Notes on the documentation	7	7.5	Setting the maximum flow temperature	24
2.1	Observing other applicable documents	7	7.6	Setting the burner anti-cycling time	24
2.2	Storing documents.....	7	7.7	Setting the maintenance interval	24
2.3	Applicability of the instructions	7	7.8	Pump diagram	24
2.4	Benchmark.....	7	7.9	Adjusting the product to large flue gas pipe lengths	25
3	Product description	7	7.10	Handing the product over to the operator.....	25
3.1	Functional elements.....	7	8	Inspection and maintenance	25
3.2	Information on the identification plate	7	8.1	Observing inspection and maintenance intervals	25
3.3	Serial number	8	8.2	Procuring spare parts	26
3.4	CE label	8	8.3	Removing the compact thermal module	26
4	Installation	8	8.4	Cleaning the heat exchanger.....	26
4.1	Unpacking the product.....	8	8.5	Descaling the heat exchanger	27
4.2	Checking the scope of delivery.....	8	8.6	Checking the burner	27
4.3	Transporting the product	8	8.7	Cleaning the condensate duct.....	27
4.4	Product dimensions and connection dimensions.....	9	8.8	Cleaning the air separation system	28
4.5	Minimum clearances and installation clearances	9	8.9	Installing the compact thermal module	28
4.6	Clearance from combustible components	9	8.10	Draining the product	28
4.7	Using the installation template.....	9	8.11	Checking the pre-charge pressure of the external expansion vessel	29
4.8	Wall-mounting the product.....	10	8.12	Completing inspection and maintenance work ...	29
4.9	Removing or installing the front casing.....	10	8.13	Checking the product for leak-tightness	29
5	Installation	10	9	Troubleshooting	29
5.1	Selecting a low loss header	11	9.1	Contacting your service partner.....	29
5.2	Gas installation	12	9.2	Calling up status codes.....	29
5.3	Hydraulics installation	13	9.3	Reading off the fault codes.....	29
5.4	Installing the air/flue pipe	14	9.4	Querying the fault memory	29
5.5	Installing and connecting the flue pipe	14	9.5	Performing diagnostics	29
5.6	Electrical installation	14	9.6	Using check programmes	29
6	Start-up	16	9.7	Resetting parameters to factory settings	29
6.1	Carrying out the initial start-up.....	16	9.8	Preparing the repair work	29
6.2	Switching on the product	16	9.9	Replacing defective components.....	30
6.3	Using check programmes	16	9.10	Completing repair work.....	30
6.4	Checking and treating the heating water/filling and supplementary water	17	10	Decommissioning the product	30
6.5	Reading off the filling pressure	18	11	Recycling and disposal	30
6.6	Reading off the filling pressure	18	12	Customer service	30
6.7	Preventing low water pressure	18	Appendix	31	
6.8	Filling and purging the heating installation	18	A	Overview of diagnostics codes	31
6.9	Flushing the heating installation for the first time ("cold")	19	B	Inspection and maintenance work – Overview	33
6.10	Filling the condensate siphon	19	C	Status codes – Overview	34
6.11	Filling the condensate trap	19	D	Overview of fault codes	35
6.12	Gas ratio setting.....	19	E	Connection diagram	37
6.13	Checking leak-tightness	22	F	Commissioning Checklist	39
6.14	Thoroughly flushing the heating installation ("hot").....	22			

G	Opening of the flue pipe.....	43
G.1	Positioning of the opening of a fan-supported flue gas guiding.....	43
H	Horizontal terminal positioning.....	44
I	Technical data.....	44
Index	46

1 Safety

1 Safety

1.1 Action-related warnings

Classification of action-related warnings

The action-related warnings are classified in accordance with the severity of the possible danger using the following warning signs and signal words:

Warning symbols and signal words



Danger!

Imminent danger to life or risk of severe personal injury



Danger!

Risk of death from electric shock



Warning.

Risk of minor personal injury



Caution.

Risk of material or environmental damage

1.2 Intended use

There is a risk of injury or death to the user or others, or of damage to the product and other property in the event of improper use or use for which it is not intended.

The product is intended as a heat generator for closed heating installations and for hot water generation.

Depending on the gas-fired boiler type, the products referred to in these instructions must only be installed and operated in conjunction with the air/flue pipe accessories listed in the other applicable documents.

Intended use includes the following:

- observance of accompanying operating, installation and servicing instructions for the product and any other system components
- installing and fitting the product in accordance with the product and system approval
- compliance with all inspection and maintenance conditions listed in the instructions.

Intended use also covers installation in accordance with the IP class.

Any other use that is not specified in these instructions, or use beyond that specified in

this document shall be considered improper use. Any direct commercial or industrial use is also deemed to be improper.

Caution.

Improper use of any kind is prohibited.

1.3 General safety information

1.3.1 Risk caused by inadequate qualifications

The following work must only be carried out by competent persons who are sufficiently qualified to do so:

- Assembly
 - Disassembly
 - Installation
 - Start-up
 - Maintenance
 - Repair
 - Decommissioning
- ▶ Observe all instructions that are included with the product.
 - ▶ Proceed in accordance with the current state of technology.
 - ▶ Observe all applicable directives, standards, laws and other regulations.

1.3.2 Risk of death from escaping gas

What to do if you smell gas in the building:

- ▶ Avoid rooms that smell of gas.
- ▶ If possible, open doors and windows fully and ensure adequate ventilation.
- ▶ Do not use naked flames (e.g. lighters, matches).
- ▶ Do not smoke.
- ▶ Do not use any electrical switches, mains plugs, doorbells, telephones or other communication systems in the building.
- ▶ If it is safe to do so, close the emergency control valve or the main isolator.
- ▶ If possible, close the gas isolator cock on the product.
- ▶ Warn other occupants in the building by yelling or banging on doors or walls.
- ▶ Leave the building immediately and ensure that others do not enter the building.
- ▶ Notify the gas supply company or the National Grid +44 (0) 800 111999 by tele-



phone once you are outside of the building.

1.3.3 Risk of death due to blocked or leaking flue gas routes

Installation errors, damage, tampering, unauthorised installation sites or similar can cause flue gas to escape and result in a risk of poisoning.

What to do if you smell flue gas in the property:

- ▶ Open all accessible doors and windows fully to provide ventilation.
- ▶ Switch off the product.
- ▶ Check the flue gas routes in the product and the flue gas diversions.

1.3.4 Risk of poisoning and burns caused by escaping hot flue gases

- ▶ Only operate the product if the air/flue pipe has been completely installed.
- ▶ With the exception of short periods for testing purposes, only operate the product when the front casing is installed and closed.

1.3.5 Risk of poisoning caused by insufficient supply of combustion air

Conditions: Open-flued operation

- ▶ Ensure that the air supply to the product's installation room is permanently unobstructed and sufficient in accordance with the relevant ventilation requirements.

1.3.6 Risk of death due to cabinet-type casing

Cabinet-type casing can give rise to dangerous situations when used on a product which is operated with an open flue.

- ▶ Ensure that the product is supplied with sufficient combustion air.

1.3.7 Risk of death due to explosive and flammable materials

- ▶ Do not use or store explosive or flammable materials (e.g. petrol, paper, paint) in the installation room of the product.

1.3.8 Risk of death due to lack of safety devices

The schematic drawings included in this document do not show all safety devices required for correct installation.

- ▶ Install the necessary safety devices in the system.
- ▶ Observe the applicable national and international laws, standards and guidelines.

1.3.9 Risk of death from electric shock

There is a risk of death from electric shock if you touch live components.

Before commencing work on the product:

- ▶ Disconnect the product from the power supply by switching off all power supplies (electrical partition with a contact opening of at least 3 mm, e.g. fuse or line protection switch).
- ▶ Secure against being switched back on again.
- ▶ Wait for at least 3 minutes until the capacitors have discharged.
- ▶ Check that there is no voltage.

1.3.10 Risk of being burned or scalded by hot components

- ▶ Only carry out work on these components once they have cooled down.

1.3.11 Risk of death from escaping flue gas

If you operate the product with an empty condensate siphon, flue gas may escape into the room air.

- ▶ In order to operate the product, ensure that the condensate siphon is always full.

1.3.12 Risk of death from escaping flue gas

If you operate the product with an empty condensate siphon, flue gas may escape into the room air.

- ▶ In order to operate the product, ensure that the condensate siphon is always full.

1.3.13 Risk of scalding from hot water

There is a risk of scalding at the hot water draw-off points if the hot water temperatures





1 Safety

are greater than 60 °C. Young children and elderly persons are particularly at risk, even at lower temperatures.

- ▶ Select a moderate set target temperature.

1.3.14 Risk of injury due to the heavy weight of the product

- ▶ Make sure that the product is transported by at least two people.

1.3.15 Risk of material damage caused by using an unsuitable tool

- ▶ Use the correct tool to tighten or loosen screw connections.

1.3.16 Risk of material damage caused by frost

- ▶ Do not install the product in rooms prone to frost.

1.3.17 Risk of corrosion damage due to unsuitable combustion and room air

Sprays, solvents, chlorinated cleaning agents, paint, adhesives, ammonia compounds, dust or similar substances may lead to corrosion on the product and in the flue gas guiding.

- ▶ Ensure that the supply of combustion air is always free of fluorine, chlorine, sulphur, dust, etc.
- ▶ Ensure that no chemical substances are stored at the installation site.
- ▶ If you are installing the product in hairdressing salons, painter's or joiner's workshops, cleaning businesses or similar locations, choose a separate installation room in which the room air is technically free of chemical substances.

1.3.18 Risk of material damage caused by leak detection sprays and liquids

Leak detection sprays and liquids block the filter of the mass flow sensor on the Venturi, and thus destroy the mass flow sensor.

- ▶ During repair work, do not apply any leak detection sprays or liquids to the covering cap on the filter of the Venturi.

1.3.19 Risk of damage to the flexible gas pipe

The corrugated gas pipe may become damaged if weight is placed on it.

- ▶ Do not suspend the compact thermal module on the flexible gas pipe, for example during maintenance work.

1.4 Regulations (directives, laws, standards)

- ▶ Observe the national regulations, standards, guidelines and laws.



2 Notes on the documentation

2.1 Observing other applicable documents

- ▶ You must observe all the operating and installation instructions included with the system components.

2.2 Storing documents

- ▶ Pass these instructions and all other applicable documents on to the system operator.

2.3 Applicability of the instructions

These instructions apply only to:

Product article number

VU GB 656/4-5 A	0010017820
-----------------	------------

2.4 Benchmark

Vaillant is a licensed member of the Benchmark Scheme.

Benchmark places responsibilities on both manufacturers and installers. The purpose is to ensure that customers are provided with the correct equipment for their needs, that it is installed, commissioned and serviced in accordance with the manufacturer's instructions by a competent person approved at the time by the Health and Safety Executive and that it meets the requirements of the appropriate Building Regulations. The Benchmark Checklist can be used to demonstrate compliance with Building Regulations and should be provided to the customer for future reference.

Installers are required to carry out installation, commissioning and servicing work in accordance with the Benchmark Code of Practice which is available from the Heating and Hotwater Industry Council who manage and promote the Scheme.

Benchmark is managed and promoted by the Heating and Hotwater Industry Council.



For more information visit www.centralheating.co.uk

3 Product description

3.1 Functional elements

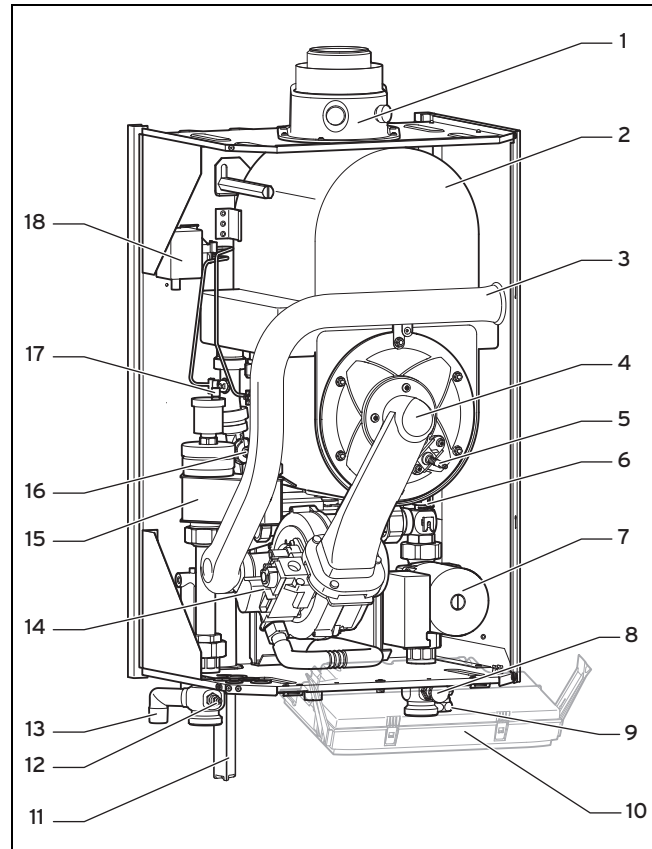

- | | | | |
|---|--|----|---------------------------------------|
| 1 | Connection for the flue pipe | 9 | Connection for expansion vessel |
| 2 | Integrated condensation heat exchanger | 10 | Electronics box |
| 3 | Air intake pipe | 11 | Condensate trap |
| 4 | Compact thermal module | 12 | Filling and drainage tap flow |
| 5 | Ignition electrode | 13 | Connection for expansion relief valve |
| 6 | Water pressure sensor | 14 | Gas valve |
| 7 | Pump | 15 | Air separator |
| 8 | Filling connection (combined filling and emptying valve) | 16 | Volume flow sensor |
| | | 17 | Automatic air vent |
| | | 18 | Flow switch with control lines |

3.2 Information on the identification plate

The identification plate is mounted on the underside of the product in the factory.

Information on the identification plate	Meaning
Serial number	for identification; 7th to 16th digits = product article number
VU...	Vaillant gas-fired wall-hung boiler for heating
ecoTEC plus	Product description
2H, G20 - 20 mbar (2 kPa)	Gas group and gas connection pressure as set at the factory
Cat.	Unit category
Types	Gas-fired boiler types

4 Installation

Information on the identification plate	Meaning
PMS	Permissible total overpressure in heating mode
PMW	Permissible total overpressure during hot water generation
T _{max.}	Max. flow temperature
ED 92/42	Current efficiency directive fulfilled with 4* rating
230 V 50 Hz	Electric connection
W	Max. electrical power consumption
IP	Level of protection
	Heating mode
P	Nominal heat output range
Q	Heat input range



Note

Make absolutely sure that the product is compatible with the gas group at the installation site.

3.3 Serial number

The serial number can be found on the identification plate.

3.4 CE label



The CE label shows that the products comply with the basic requirements of the applicable directives as stated on the identification plate.

The declaration of conformity can be viewed at the manufacturer's site.

4 Installation

4.1 Unpacking the product

1. Remove the product from its box.
2. Remove the protective film from all parts of the product.

4.2 Checking the scope of delivery

- ▶ Check that the scope of delivery is complete and intact.

4.2.1 Scope of delivery

Number	Description
1	Hanging bracket
1	Heat generator
1	Condensate drain hose
1	Expansion relief valve
1	Compression joint, gas G 1
1	Seal
1	Condensate trap's cartridge installation kit
1	Enclosed documentation

Number	Description
1	Bag with small parts

4.3 Transporting the product

4.3.1 General

- ▶ Hold the load as close as possible to your body. Do not twist your body – instead, reposition your feet.
- ▶ If the unit is being lifted by two persons, ensure your movements are coordinated during lifting.
- ▶ Avoid bending your upper body – do not lean forwards or to the side.
- ▶ Wear appropriate cut-resistant and non-slip gloves to protect yourself against sharp edges and maintain a safe and secure grip.
- ▶ If required, get somebody to assist you in this.

4.3.2 Unloading the box from the delivery van

- ▶ It is recommended that two people lift the unit together.
- ▶ Lift the box using the straps provided.
- ▶ Use safe lifting techniques – keep your back straight and bend your legs at the knee.
- ▶ Hold the load as close as possible to your body.
- ▶ If the unit is being lifted by two persons, ensure your movements are coordinated during lifting.
- ▶ If required, get somebody to assist you in this.

4.3.3 Transporting the box from the delivery point to the installation site – ground floor

- ▶ It is recommended that two people lift the unit together.
- ▶ Use safe lifting techniques – keep your back straight and bend your legs at the knee.

4.4 Product dimensions and connection dimensions

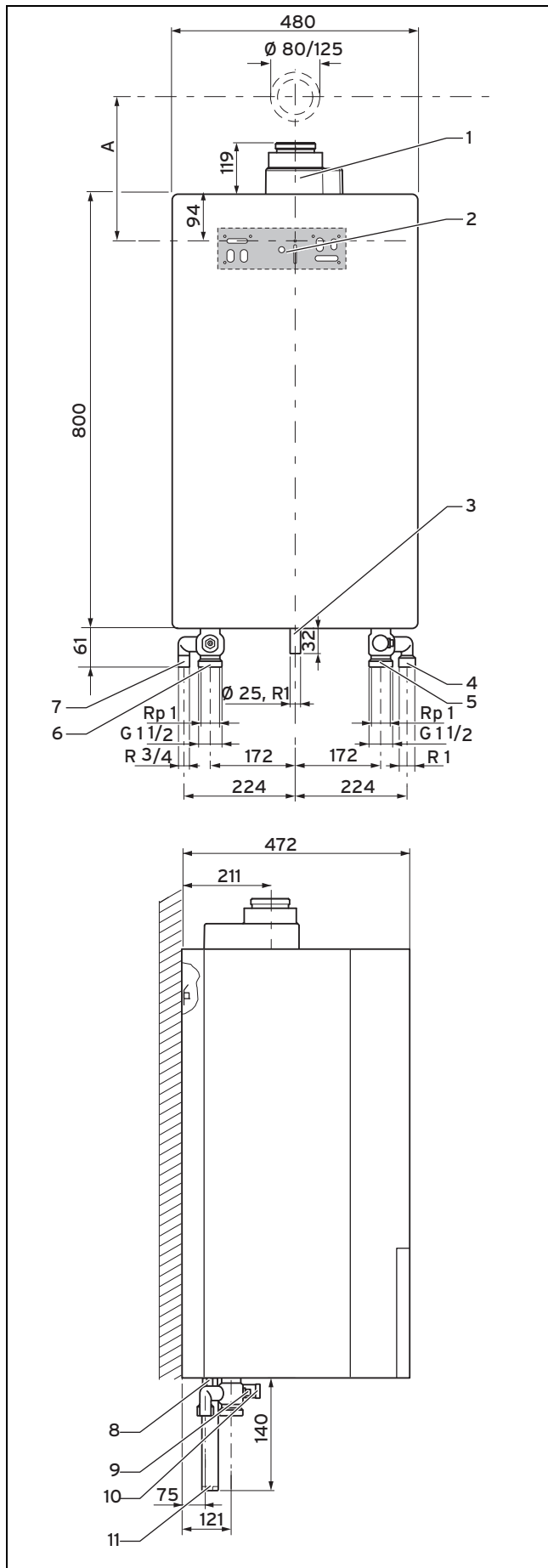

- | | | | |
|---|--|----|---|
| 1 | Flue gas connection, 80/125 diameter | 7 | Expansion relief valve connection |
| 2 | Hanging bracket | 8 | Condensate discharge connection |
| 3 | Gas pipe, 25 mm diameter, gas connection R1" | 9 | Flow drain opening |
| 4 | Expansion vessel connection | 10 | Filling connection option (combined filling and emptying valve) |
| 5 | Heating return connection | 11 | Condensate trap's cartridge |
| 6 | Heating flow connection | | |

Consult the installation template that is supplied to find the dimension A.

4.5 Minimum clearances and installation clearances

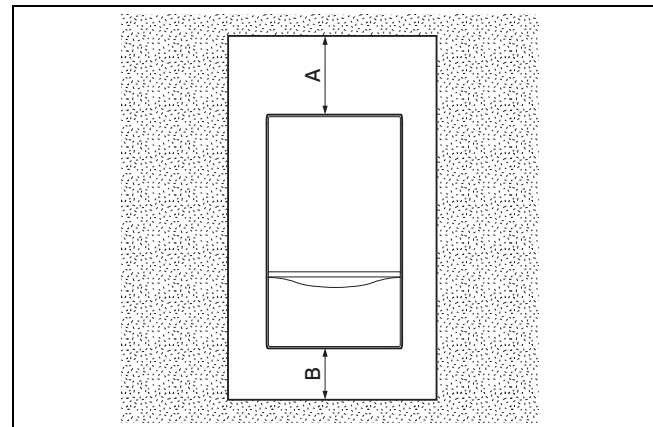

A 500 mm B 400 mm

- When using the accessories, observe the minimum clearances/installation clearances.

4.6 Clearance from combustible components

- It is not necessary to maintain a clearance between the product and components made of combustible materials that go beyond the minimum clearances.

4.7 Using the installation template

1. Position the installation template vertically over the installation site.
2. Secure the template to the wall.
3. Mark on the wall all the points required for the installation.
4. Remove the installation template from the wall.
5. Drill all the holes required.
6. Make any perforations necessary.

5 Installation

4.8 Wall-mounting the product

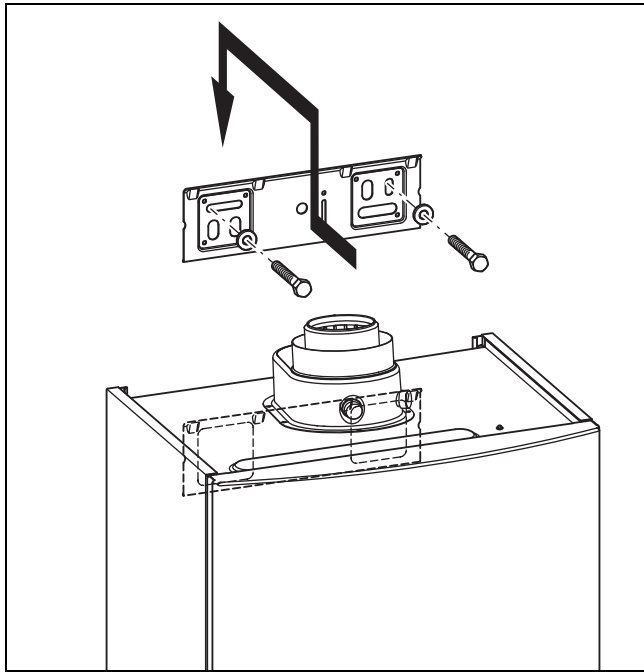

1. Check whether the wall has sufficient load-bearing capacity to bear the operational weight of the product.
2. Check if the supplied fixing material may be used for the wall.

Conditions: The load-bearing capacity of the wall is sufficient; the fixing material is permitted for the wall

- ▶ Wall-mount the product as described.

Conditions: The load-bearing capacity of the wall is not sufficient

- ▶ Ensure that wall-mounting apparatus on-site has a sufficient load-bearing capacity. Use individual stands or primary walling, for example.
- ▶ Do not wall-mount the product if you cannot provide wall-mounting apparatus with a sufficient load-bearing capacity.

Conditions: The fixing material may not be used for the wall

- ▶ Wall-mount the product as described using the permitted fixing material provided on-site.

4.9 Removing or installing the front casing

4.9.1 Removing the front casing

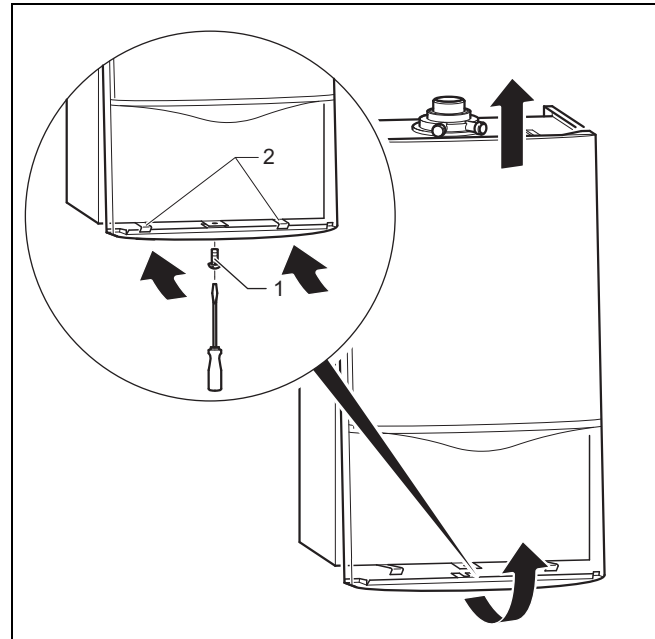

1. Undo the bolt (1).
2. Push in both retaining clips (2) so that the front casing is released.
3. Pull the front casing forwards at the bottom edge.
4. Lift the front casing upwards from the bracket.

4.9.2 Installing the front casing

1. Place the front casing on the upper brackets.
2. Push the front casing onto the product until both retaining clips (2) snap into place at the front casing.
3. Secure the front casing by tightening the bolt (1).

5 Installation



Danger!

Risk of explosion or scalding caused by incorrect installation.

Stresses in the connection cable can cause leaks.

- ▶ Make sure there is no stress in the connection cables when they are installed.



Caution.

Risk of material damage caused by changes to the connected pipes.

- ▶ Only bend connection pipes if they have not yet been connected to the product.



Caution.
Risk of material damage caused by residues in the pipelines.

Welding remnants, sealing residues, dirt or other residues in the pipelines may damage the product.

- ▶ Flush the heating installation thoroughly before installing the product.

Seals made of rubber-like materials may be subject to plastic deformation, which can lead to pressure losses. We recommend using seals made of a paste-like fibre material.

You must only start up the product if a sufficiently dimensioned low loss header has been installed between the heat generation circuit and the heating circuit or cylinder charging circuit.

5.1 Selecting a low loss header

The low loss header disconnects the heat generator from the heating system. This means that the system is no longer dependent on the heat generator's remaining feed head. In conjunction with the heating pump, the low loss header ensures that a sufficiently high minimum quantity of water is always circulating through the heat generator.

Heating system output	Heating system spread		
	10 K	15 K	20 K
Individual unit	WH 160	WH 95	WH 95
Dual cascade	WH 280	WH 160	WH 95
Three-unit cascade	WH 280	WH 280	WH 160

For old systems in particular, we recommend installing a heating dirt filter in the return to the low loss header (not to the product). This protects the product against dirt from the system. Ensure that there is sufficient dimensioning in order to prevent it from blocking quickly and to prevent high pressure losses.

You do not need any electrical accessories when using a low loss header. You can connect simple systems directly inside the electronics box; see the connection diagram (→ Page 37).

5.1.1 Heating circuit connection with low loss header

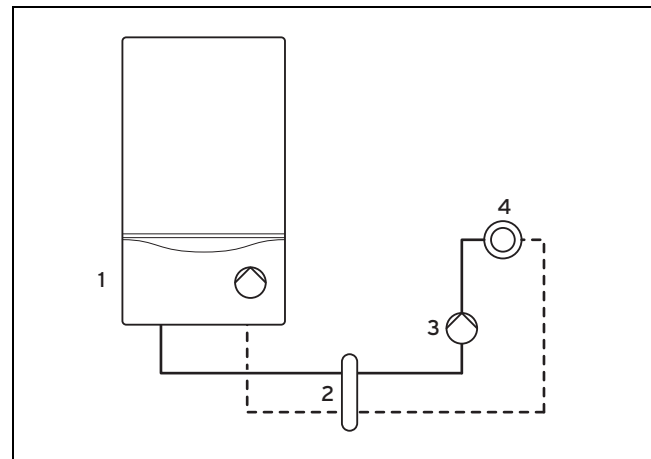

- 1 Product with internal pump
- 2 Low loss header
- 3 External heating pump
- 4 Consumer (e.g. heating circuit)

The product can directly operate a heating circuit via the low loss header.

- ▶ Downstream of the low loss header, select a heating pump that is appropriate for the system.
- ▶ For multi-circuit systems, pay additional attention to the control system accessories.

The settings for the internal pump are made at the factory.

- ▶ Connect the external heating pump to the grey ProE plug X13.
- ▶ Set the diagnostics code **D.26** to 2.

5.1.2 Cylinder priority switching via low loss header

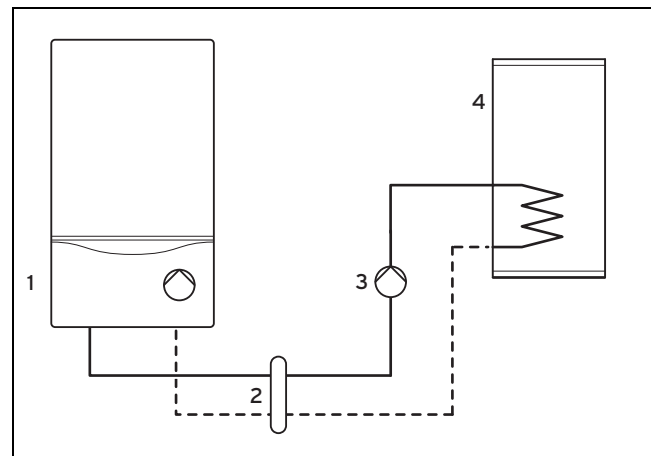

- 1 Product with internal pump
- 2 Low loss header
- 3 External cylinder charging pump
- 4 Consumer (e.g. cylinder charging circuit)

The product's electronics are designed in such a way that you can connect one cylinder charging circuit and one heating circuit directly without the need for accessories. The cylinder charging circuit connection downstream of the low loss header means that you can select an individual cylinder size and a cylinder charging pump.

5 Installation

- ▶ Note that non-return valves or mixer circuits may be required in order to eliminate cross-flow to other circuits or the effects of high temperatures from the cylinder charging circuit.
- ▶ Connect the cylinder charging pump to the ProE plug X6.

To start up the cylinder charging pump, it is not necessary to set a diagnostics code. The slot on the PCB is reserved for the cylinder charging pump.

5.1.3 Cylinder priority switching and heating circuit via low loss header

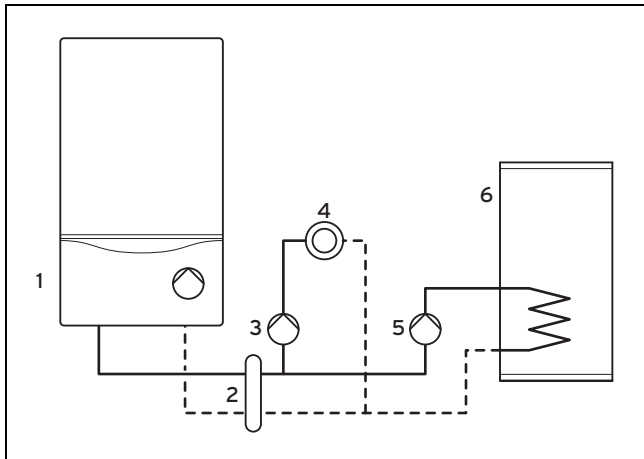

1	Product with internal pump	4	Consumer (e.g. heating circuit)
2	Low loss header	5	External cylinder charging pump
3	External heating pump	6	Cylinder

The product's electronics are designed in such a way that you can connect a standard system (one heating circuit and one cylinder charging circuit) without the need for special accessories. If several circuits are required, special accessories and/or controllers are required. The product's remaining feed head for the low loss header is sufficient. You can individually design the cylinder charging circuit connection downstream of the low loss header (cylinder size, cylinder charging pump size, etc.).

- ▶ Note that non-return valves or mixer circuits may be required in order to eliminate cross-flow to other circuits or the effects of high temperatures from the cylinder charging circuit.

To start up the cylinder charging pump, it is not necessary to set a diagnostics code. The slot on the PCB is reserved for the cylinder charging pump.

The settings for the internal pump are made at the factory.

- ▶ Connect the cylinder charging pump to the ProE plug X6.
- ▶ Connect the external heating pump to the grey ProE plug X13.
- ▶ Set the diagnostics code **D.26** to 2.

5.2 Gas installation

5.2.1 Checking the gas meter

- ▶ Make sure that the existing gas meter is capable of passing the rate of gas supply required.

5.2.2 Performing the gas installation



Caution.

Risk of material damage due to the gas leak-tightness test.

At a test pressure of >11 kPa (110 mbar), gas leak-tightness tests may cause damage to the gas valve.

- ▶ If, during gas leak-tightness tests, you also place the gas lines and the gas valve in the product under pressure, use a max. test pressure of 11 kPa (110 mbar).
- ▶ If you cannot limit the test pressure to 11 kPa (110 mbar), close any gas isolator cocks that are installed upstream from the product before you carry out the gas leak-tightness test.
- ▶ If, during gas leak-tightness tests, you have closed the gas isolator cock that is installed upstream of the product, relieve the gas line pressure before you open this gas isolator cock.



Note

Do **not** reduce the gas pipe dimension downstream of the gas meter. Maintain the dimension right up to the product. Select the correct gas isolator cock. When using an atmospheric sensing device, select the next-highest pipe cross-section.

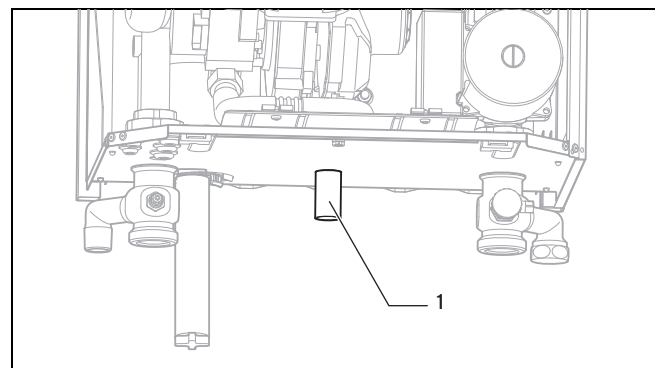

- ▶ Install the gas line without tension in accordance with the recognised rules of technology.
- ▶ Make sure that the existing gas meter is capable of passing the rate of gas supply required.
- ▶ Remove the residues from the gas pipe by blowing through the gas pipe beforehand.
- ▶ Screw the gas pipe (1) to the (preinstalled) gas isolator cock so that it is gas-tight. To do this, use the enclosed compression joint G 1.
- ▶ Purge the gas pipe before start-up.

5.2.3 Checking the gas line for leak-tightness

- ▶ Check the entire gas line properly for leak-tightness.

5.3 Hydraulics installation



Caution. Risk of material damage caused by corrosion

Due to non-diffusion-tight plastic pipes in the heating installation, air gets into the heating water. Air in the heating water causes corrosion in the heat generator circuit and in the product.

- ▶ If you use non-diffusion-tight plastic pipes in the heating installation, ensure that no air gets into the heat generator circuit.



Caution. Risk of material damage due to heat transfer during soldering.

Heat that is transferred during soldering may cause damage to the seals in the service valves.

- ▶ Do not solder the connection pieces if the connection pieces are screwed to the service valves.

- ▶ If you are using plastic pipes in the heating installation, you must install a suitable limit thermostat on-site at the heating flow. The limit thermostat is required to protect the heating installation against temperature-related damage if a fault occurs.
- ▶ Install an expansion vessel on-site in the heating return, as close to the product as possible.

5.3.1 Connecting the heating flow and heating return

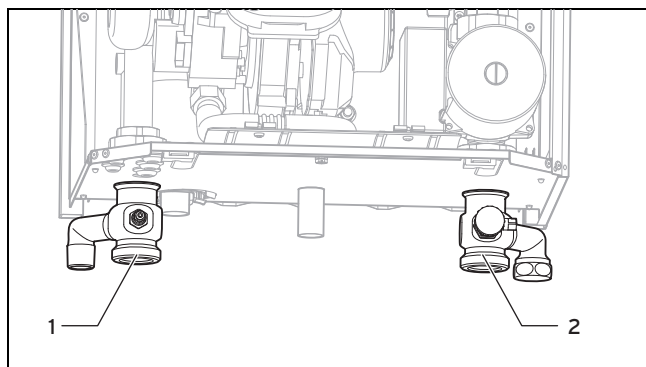

1. Install service valves properly at the flow connection (1) and the return connection (2).
2. Establish the heating connections in accordance with the relevant standards.

5.3.2 Installing the expansion relief valve

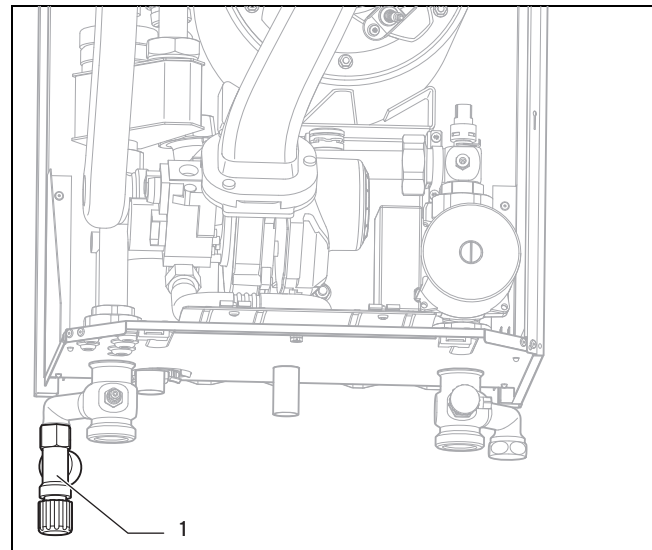

1. Install the enclosed expansion relief valve.
2. Lay as short a drain line as possible for the expansion relief valve, at a downward gradient.
3. Terminate the drain line in such a way that escaping water or steam cannot cause injury to persons or damage to electronic components.
4. Make sure that the line end is visible.

5.3.3 Connecting the condensate drain pipework

5.3.4 Connecting the condensate drain pipework



Danger! Risk of death from escaping flue gases!

The condensate drain pipework of the condensate trap must not be connected tightly to waste-water piping because, otherwise, the internal condensate trap may be drained fully and flue gas may escape.

- ▶ Do not connect the condensate drain pipework tightly to the waste-water piping.

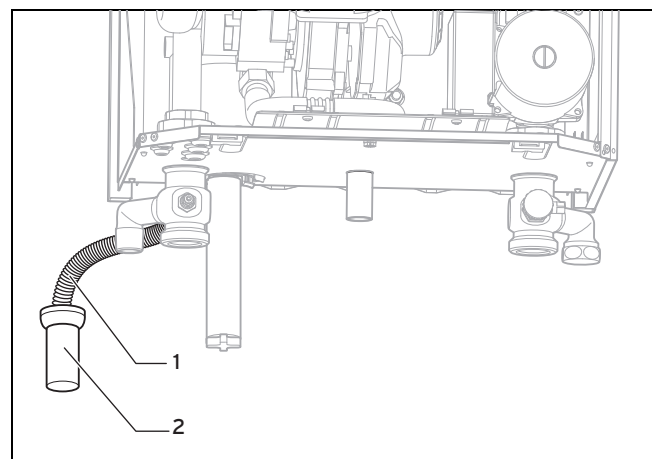

Condensate forms in the product during combustion. The condensate drain pipework (1) routes the condensate to the waste water connection via a tundish (2).

5 Installation

- ▶ Install the enclosed condensate drain pipework (hose) (1).



Note

If the length of the enclosed hose is not sufficient, use only pipes that are made from acid-resistant material (e.g. plastic) for the condensate drain pipework and also for the waste-water piping.

- ▶ Suspend the condensate drain pipework above the pre-installed tundish (2).

5.4 Installing the air/flue pipe

1. You can find out which flue pipes may be used by consulting the enclosed flue pipe installation manual.



Danger!

Risk of personal injury and material damage due to unapproved air/flue pipes.

Vaillant boilers are certified only with Vaillant original air/flue pipes. The use of other accessories may cause personal injury and material damage, as well as operating faults. For installation type B23P, third-party accessories are also permitted (see the technical data in the appendix).

- ▶ Only use Vaillant original air/flue pipes.
- ▶ If third-party accessories are permitted for B23P, ensure that the flue pipe connections are properly routed, sealed and secured against slipping out.

2. Install the flue pipe using the installation manual.

5.4.1 Information on installing the B23

A flue gas pipe in accordance with unit type B23 (open-flued gas-fired wall-hung boilers) requires careful planning and implementation. During planning, observe the technical data for the product and refer to the recognised rules of technology.

5.4.2 Information and specifications for installing the B23P

The flue gas system must at least correspond to the classification T 120 P1 W 1 in accordance with EN 1443. The maximum pipe length must be calculated based on the permissible pressure difference in the technical data.

The maximum pipe length (straight pipe only) corresponds to the maximum permitted flue gas pipe length without any elbows. If elbows are used, the maximum pipe length must be reduced in accordance with the dynamic flow characteristics of the elbows. Elbows must not be connected directly after one another as this method dramatically increases pressure losses.

In particular, if the flue pipe is installed in cold rooms or outside of the building, the freezing point on the surface of the inside of the pipe may be reached. A proven design in accordance with EN 13384-1 for a maximum boiler load at a flue gas temperature of 40 °C must be used to prevent this

problem. The product must not be connected to a cascade flue gas installation that is being used by other units.

- ▶ Observe the applicable international, national and local regulations for flue gas systems, in particular for installations in living rooms. Inform the operator how to correctly operate the product.

5.5 Installing and connecting the flue pipe

1. You can find out which flue pipes may be used by consulting the enclosed flue pipe installation manual.
2. Observe the information on positioning the opening for the flue pipe. This information can be found in the appendix.



Caution.

Risk of poisoning due to escaping flue gas.

Mineral-oil-based greases can damage the seals.

- ▶ Instead of grease, use only water or commercially available soft soap to aid installation.

3. Install the flue pipe using the installation manual.

5.6 Electrical installation



Danger!

Risk of death from electric shock as a result of an improper electrical connection!

An improper electrical connection may negatively affect the operational safety of the product and result in material damage or personal injury.

- ▶ Only carry out the electrical installation if you are a trained competent person and are qualified for this work.
- ▶ Observe all applicable laws, standards and directives in the process.
- ▶ Earth the product.



Danger!

Risk of death from electric shock!

Touching live connections may cause serious personal injury. Since mains connection terminals L and N also remain live even if the boiler main switch is turned off:

- ▶ Switch off the power supply.
- ▶ Secure the power supply against being switched on again.

5.6.1 Opening or closing the electronics box

5.6.1.1 Opening the electronics box

1. Remove the front casing. (→ Page 10)

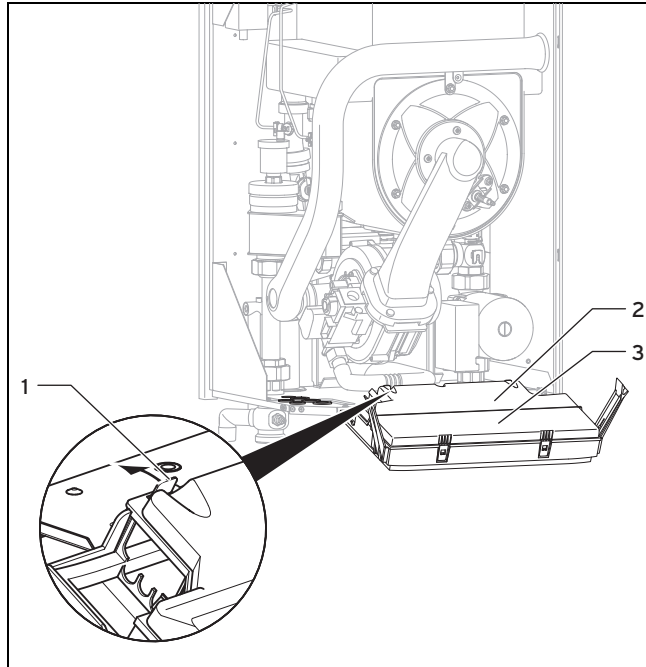

2. Tilt the electronics box (3) forwards.
3. Detach the left and right clips (1) from the brackets.
4. Fold up the cover (2).

5.6.1.2 Closing the electronics box

1. Close the cover (2) by pushing it downwards onto the electronics box (3).
2. Ensure that all of the clips (1) audibly click into the brackets.
3. Tilt the electronics box upwards.

5.6.2 Establishing the power supply

1. Observe the relevant regulations and the enclosed connection diagram.
2. Provide one common electricity supply for the boiler and for the corresponding controller:
 - Power supply: Single-phase, 230 V, 50 Hz
 - Fuse protection: ≤ 3 A
3. Connect the product using a fixed connection and a partition with a contact opening of at least 3 mm (e.g. fuses or power switches), see Connection diagram (→ Page 37).
4. Use a flexible line for the mains connection line, which is routed through the cable duct into the product.
5. Carry out the wiring. (→ Page 15)
6. Screw the ProE plug supplied to a suitable three-core mains connection cable which complies with the relevant standards.
7. Close the electronics box. (→ Page 15)
8. Make sure that access to the power supply is always available and is not covered or blocked.

5.6.3 Carrying out the wiring



Caution.

Risk of material damage caused by incorrect installation.

Mains voltage at the incorrect plug terminals on the ProE system may destroy the electronics.

- ▶ Do not connect any mains voltage to the eBUS terminals (+/-).
- ▶ Only connect the power supply cable to the terminals marked for the purpose.

1. Route the supply lines of the components to be connected through the cable duct provided on the underside of the product on the left.
2. Use strain reliefs.
3. Shorten the supply lines as necessary.
4. Only strip the outer sheathing of flexible lines to a maximum of 30 mm to prevent short circuits if a strand accidentally comes loose.
5. Ensure the inner conductor insulation is not damaged when stripping the outer sheathing.
6. Only strip inner conductors just enough to establish good, sound connections.
7. To avoid short circuits resulting from loose individual wires, fit conductor end sleeves on the stripped ends of the conductors.
8. Screw the respective ProE plug to the supply line.
9. Check whether all conductors are sitting mechanically securely in the terminals of the ProE plug. Remedy this if necessary.
10. Plug the ProE plug into the associated PCB slot.

5.6.4 Installing the controller

- ▶ Install the controller if necessary.

5.6.5 Connecting controllers to the electronic system

1. Carry out the wiring. (→ Page 15)
2. If you do not connect a room/timer thermostat, bridge terminals 3 and 4, if no bridge exists.
3. If you connect a room/timer thermostat to terminals 3 and 4, remove the bridge.
4. If you connect a weather compensator or room thermostat (continuous control – connection terminals 7, 8, 9), leave the bridge inserted between terminal 3 and 4.
5. If you connect a limit thermostat (contact thermostat) for underfloor heating systems, remove the bridge on the blue ProE plug (contact thermostat) and connect the limit thermostat here.
6. Close the electronics box. (→ Page 15)
7. To access pump operating mode 1 (continuously running pump) for multi-circuit controllers, set **D.18** Pump operating mode (→ Page 23) from 3 (intermittent pump) to 1.

6 Start-up

5.6.6 Connecting a low loss header sensor

1. Connect the low loss header sensor to the edge connector X41 at terminal RF or to the controller. When doing so, observe the instructions for the controller.
2. Plug the edge connector into the PCB slot X41.
3. Activate the low loss header function at the controller.

5.6.7 Connecting a cylinder charging pump

- ▶ Connect an external cylinder charging pump (to be fitted on-site) to the pink ProE plug X6.

5.6.8 Connecting additional components

You can actuate an additional component with the aid of the auxiliary relay that is installed, and you can actuate two other components with the multi-functional module.

The following components can be actuated:

1. Circulation pump
2. External pump
3. Cylinder charge pump
4. Extractor hood
5. External solenoid valve
6. External fault signal
7. Not active
8. eBUS remote control (not active)
9. Legionella protection pump (not active)
10. Not active.

5.6.8.1 Using the auxiliary relay

1. Connect an additional component directly to the integrated auxiliary relay using the grey plug on the PCB.
2. Carry out the wiring. (→ Page 15)
3. To start up the connected component, select the component via **D.26**, see Calling up diagnostics codes (→ Page 23).

5.6.8.2 Using the VR 40 ("2 in 7" multi-functional module)

1. Install the components in accordance with the respective instructions.
2. Select **D.27** (→ Page 23) to actuate relay 1 on the multi-functional module.
3. Select **D.28** (→ Page 23) to actuate relay 2 on the multi-functional module.

5.6.9 Actuating the circulation pump according to requirements



Note

The product's electronics provide the opportunity to control a domestic hot water cylinder's circulation pump as necessary (similar to an automatic light unit for stairs). It is controlled using an external button (to be fitted on-site) that can be installed anywhere in the dwelling, e.g. in the bathroom or kitchen. When the button is pressed, the circulation pump starts up. The pump is switched on again after five minutes. Several buttons can be pressed in parallel. Irrespective of the external control of the circulation pump, the "Control by programmable time periods" function continues to be possible when a controller is used.

Conditions: Domestic hot water cylinder connected

- ▶ Carry out the wiring. (→ Page 15)
- ▶ Connect the supply line for an external button using terminals 1 (0) and 6 (functional drawing) on the X41 edge connector, which is supplied with the controller.
- ▶ Plug the edge connector into the PCB slot X41.

6 Start-up

6.1 Carrying out the initial start-up

Initial start-up must be carried out by a customer service technician or an authorised competent person using the commissioning checklist. The commissioning checklist in the appendix (→ Page 39) of the installation instructions must be filled in and stored carefully along with the unit's documentation.

- ▶ Carry out the start-up procedure using the commissioning checklist in the appendix.
- ▶ Fill in and sign the commissioning checklist.

6.2 Switching on the product

- ▶ Set the product's main switch to 1.
 - ◀ The basic display appears on the display.





6.3 Using check programmes

By activating various check programmes, you can trigger special functions on the product.





Display	Meaning
P.0	<p>Purging check programme: The internal pump is cyclically actuated. The heating circuit and the hot water circuit are purged via the automatic air vent (the cap of the automatic air vent must be released).</p> <p>1 x : Start heating circuit purging (display view: HP)</p> <p>2 x : Start cylinder charging circuit purging (display view: SP)</p> <p>3 x : Exit purging programme</p> <p>Note The purging programme runs for 6.5 minutes per circuit and then terminates.</p>

Display	Meaning
P.1	Maximum load check programme: After successful ignition, the product is operated at maximum heat input.
P.2	Minimum load check programme: After successful ignition, the product is operated at minimum heat input.
P.5	SCO (safety cut-out) check programme: The burner is switched on and the control is switched off so that the product heats up until it reaches the safety cut-out's switch-off temperature of 97 °C while avoiding a regular shutdown.
P.6	Check programme, diverter valve mid-position: (not active)

You can start check programmes P.0 to P.6 by either:

- Switching on the main switch and, at the same time, pressing and holding  for five seconds or
- Pressing and holding  and  at the same time, releasing  and pressing and holding  for five seconds

The displays shows P. 0.

- ▶ Press  to move up the check programmes in numerical order.
- ▶ Press  to start the check programme.
- ▶ Press  and  at the same time to exit the check programmes. You can also exit the check programmes by not pressing any button for 15 minutes.

6.4 Checking and treating the heating water/filling and supplementary water



Caution.

Risk of material damage due to poor-quality heating water

- ▶ Ensure that the heating water is of sufficient quality.

- ▶ Before filling or topping up the system, check the quality of the heating water.

Checking the quality of the heating water

- ▶ Remove a little water from the heating circuit.
- ▶ Check the appearance of the heating water.
- ▶ If you ascertain that it contains sedimentary materials, you must desludge the system.
- ▶ Use a magnetic rod to check whether it contains magnetite (iron oxide).
- ▶ If you ascertain that it contains magnetite, clean the system and apply suitable corrosion-protection measures, or fit a magnet filter.
- ▶ Check the pH value of the removed water at 25 °C.
- ▶ If the value is below 8.2 or above 10.0, clean the system and treat the heating water.
- ▶ Ensure that oxygen cannot get into the heating water.

Checking the filling and supplementary water

- ▶ Before filling the system, measure the hardness of the filling and supplementary water.

Treating the filling and supplementary water

- ▶ Observe all applicable national regulations and technical standards when treating the filling and supplementary water.

Provided the national regulations and technical standards do not stipulate more stringent requirements, the following applies:

You must treat the heating water in the following cases:

- If the entire filling and supplementary water quantity during the operating life of the system exceeds three times the nominal volume of the heating installation, or
- If the guideline values listed in the following table are not met, or
- If the pH value of the heating water is less than 8.2 or more than 10.0.

Total heating output	Water hardness at specific system volume ¹⁾					
	≤ 20 l/kW		> 20 l/kW ≤ 50 l/kW		> 50 l/kW	
kW	ppm CaCO ₃	mol/m ³	ppm CaCO ₃	mol/m ³	ppm CaCO ₃	mol/m ³
< 50	< 300	< 3	200	2	2	0.02
> 50 to ≤ 200	200	2	150	1.5	2	0.02
> 200 to ≤ 600	150	1.5	2	0.02	2	0.02
> 600	2	0.02	2	0.02	2	0.02

1) Nominal capacity in litres/heating output; in the case of multi-boiler systems, the smallest single heating output is to be used.



Caution.

Risk of material damage if the heating water is treated with unsuitable additives.

Unsuitable additives may cause changes in the components, noises in heating mode and possibly subsequent damage.

- ▶ Do not use any unsuitable frost and corrosion protection agents, biocides or sealants.

No incompatibility with our products has been detected to date with proper use of the following additives.

- ▶ When using additives, follow the manufacturer's instructions without exception.

We accept no liability for the compatibility of any additive or its effectiveness in the rest of the heating system.

Additives for cleaning measures (subsequent flushing required)

- Adey MC3+
- Adey MC5
- Fernox F3
- Sentinel X 300
- Sentinel X 400

Additives intended to remain permanently in the system

- Adey MC1+
- Fernox F1

6 Start-up

- Fernox F2
- Sentinel X 100
- Sentinel X 200

Additives for frost protection intended to remain permanently in the system

- Adey MC ZERO
 - Fernox Antifreeze Alpha 11
 - Sentinel X 500
- ▶ If you have used the above-mentioned additives, inform the operator about the measures that are required.
- ▶ Inform the operator about the measures required for frost protection.

6.5 Reading off the filling pressure

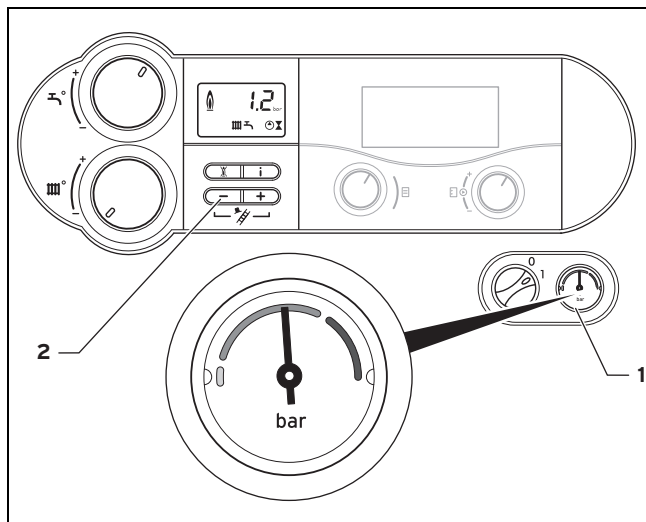

The product has an analogue pressure gauge **(1)** and a digital pressure display.

- ▶ To read off the digital value, press **(2)**.

If the heating installation is full, the indicator on the pressure gauge must point to the upper half of the grey area when the heating installation is cold in order to ensure that it operates smoothly. This corresponds to a filling pressure of between 0.1 MPa and 0.2 MPa (1.0 bar and 2.0 bar).

If the heating installation extends over several storeys, higher filling pressures may be required to avoid air entering the heating installation.

6.6 Reading off the filling pressure

The product comes with a digital pressure indicator.

- ▶ To read off the digital value for the filling pressure, press the **(2)** button briefly.
 - ◁ The display will show the filling pressure for approximately 5 seconds.

If the heating installation is full, the filling pressure must be between 0.1 MPa and 0.2 MPa (1.0 bar and 2.0 bar) to ensure it operates properly.

If the heating installation extends over several storeys, higher filling pressures may be required to avoid air entering the heating installation.

6.7 Preventing low water pressure

To prevent damage to the heating installation that is caused by low filling pressure, the product is fitted with a water pressure sensor. If the filling pressure falls below 0.06 MPa (0.6 bar), the product indicates low pressure by displaying a flashing pressure value. If the filling pressure falls below 0.03 MPa (0.3 bar), the product switches off. The display shows **F.22**.

- ▶ Top up the heating water to start the product up again.

The pressure value flashes on the display until a pressure of 0.11 MPa (1.1 bar) or higher has been reached.

- ▶ If you notice frequent losses in pressure, determine and eliminate the cause.

6.8 Filling and purging the heating installation

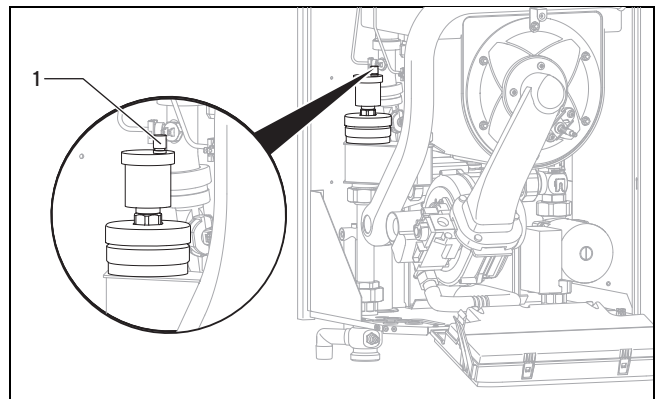

1. Flush the heating installation thoroughly before filling it.
2. Undo the cap of the automatic air vent **(1)** by one to two rotations and leave it open, as the product purges itself via the automatic air vent even in continuous mode.
3. Observe the information on the topic of treating (→ Page 17) heating water.
4. Connect the filling and drainage tap in the heating installation to a heating water supply in accordance with the relevant standards.
5. Open the heating water supply.
6. Open all thermostatic radiator valves.
7. If necessary, check that both service valves on the product are open.
8. Slowly open the filling and drainage tap so that the water flows into the heating installation.
9. Purge the lowest radiator until water flows out of the purging valve without bubbles.
10. Purge all other radiators until the heating installation is completely filled with water.
11. Close all purging valves.
12. Monitor the rising filling pressure in the heating installation.
13. Fill with water until the required filling pressure is reached.
14. Close the filling and drainage tap and the heating water supply.
15. Check all connections and the entire system for leaks.
16. To purge the heating installation, select the check programme **P.0**.
 - ◁ The product does not start up, the internal pump operates intermittently and purges either the heating

circuit or the hot water circuit. The display shows the filling pressure of the heating installation.

17. To be able to carry out the purging process properly, the heating installation filling pressure must not fall below the minimum filling pressure.
 - Minimum heating installation filling pressure: 0.08 MPa (0.80 bar)



Note

The check programme **P.0** runs for 6.5 minutes per circuit. At the end of the filling procedure, the filling pressure of the heating installation should be at least 0.02 MPa (0.2 bar) above the counter-pressure of the expansion vessel ("Exp") ($P_{\text{Installation}} \geq P_{\text{Exp}} + 0.02 \text{ MPa}$ (0.2 bar)).

18. If there is still too much air in the heating installation at the end of the check programme **P.0**, repeat the check programme.
19. Check all connections for leaks.

6.9 Flushing the heating installation for the first time ("cold")



Note

The complete heating system must be flushed at least twice: Once with cold water and once with hot water in accordance with the following instructions.

1. Check whether all thermostatic radiator valves and both service valves on the product are open.
2. Connect a hose to the drain valve that is located at the lowest position in the heating system.
3. Open the radiator valves and the drain valves so that the water can drain quickly. Start at the next point in the system and open the purging valves on the radiators so that the contaminated water can completely drain.
4. Close the drain cocks.
5. Refill the heating system with water.
6. Check that the expansion relief valve of the heating system is functioning correctly by turning the handle on the valve.
7. Check the pressure in the heating system and top up with water if necessary.
8. Close the filling valve and the cold water valve.

6.10 Filling the condensate siphon



Danger!

Risk of poisoning due to escaping flue gas.

An empty or insufficiently filled condensate siphon may allow flue gas to escape into the room air.

- ▶ Fill the condensate siphon with water before starting up the product.

6.11 Filling the condensate trap



Danger!

Risk of poisoning due to escaping flue gas.

An empty or insufficiently filled condensate trap may allow flue gas to escape into the room air.

- ▶ Fill the condensate trap with water before starting up the product.

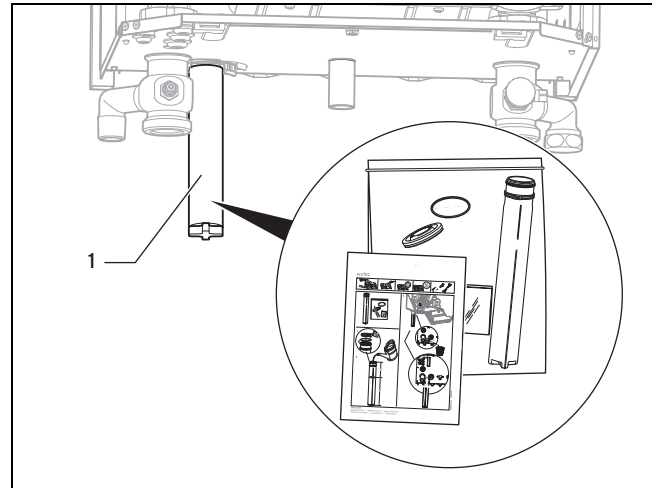

1. Install the condensate trap's cartridge (1) in accordance with the enclosed installation manual.
2. Fill the condensate trap in accordance with the enclosed description.

6.12 Gas ratio setting

6.12.1 Checking the factory setting



Caution.

An incorrect gas group setting may cause operating faults or a reduction in the working life of the product.

If the product design does not match the local gas group, malfunctions will occur or you will have to replace product components prematurely.

- ▶ Before you start up the product, compare the gas group information on the identification plate with the gas group available at the installation site.

The product's combustion has been factory tested and is preset for operation with the gas group indicated on the identification plate. In some supply areas, these settings may need to be adjusted at the installation site.

Conditions: The product design is **not compatible** with the local gas group

- ▶ Do not start up the product.

6 Start-up

Conditions: The product design is compatible with the local gas group

- ▶ Proceed as described below.

6.12.2 Checking the leak-tightness of the flue gas installation and flue gas recirculation

1. Check the flue gas installation is intact in accordance with the latest gas safe technical bulletin and information supplied in the installation instructions.
2. For extended flue gas installations check for flue gas recirculation using the air analysis point.
3. Use a flue gas analyser.
4. If you discover CO or CO₂ in the supply air, search for the leak in the flue gas installation or for signs of flue gas recirculation.
5. Eliminate the damage properly.
6. Check again whether the supply air contains any CO or CO₂.
7. If you cannot eliminate the damage, do not start up the product.

6.12.3 Checking the gas flow rate

The boiler is fitted with a multifunctional automatic gas valve which ensures that the precise air/gas ratio is provided under all operating conditions.

The gas flow rate has been set during production and does not require adjustment. With the front casing fitted check the gas flow rate of the boiler as follows:

- ▶ Start up the product with the check programme **P.01**.
- ▶ In addition, ensure that maximum heat can be dissipated into the heating system by turning up the room thermostat.
- ▶ Wait at least 5 minutes until the boiler has reached its operating temperature.
- ▶ Ensure that all other gas appliances in the property are turned off.
- ▶ Measure the gas flow rate at the gas meter.
- ▶ Compare the measured values with the corresponding values in the table.

Q _{nw} from the data plate	H gas in m ³ /h		
	Nom.	+5 %	-10 %
46,0	4,87	5,13	4,38
65,0	6,88	7,24	6,19

Conditions: Gas flow rate not in the permissible range

- ▶ Check all of the piping and ensure that the gas flow rates are correct.
- ▶ Only put the product into operation once the gas flow rates have been corrected.

Conditions: Gas flow rate in the permissible range

- ▶ End the check programme **P.01**.
- ▶ Allow the boiler to cool down by allowing pump overrun to operate for a minimum of 2 minutes.
- ▶ Record the boiler maximum gas flow rate onto the Benchmark gas boiler commissioning checklist.

6.12.4 Checking the gas flow pressure

1. Ensure that the gas inlet working pressure can be obtained with all other gas appliances in the property working.
2. Close the gas isolator cock.

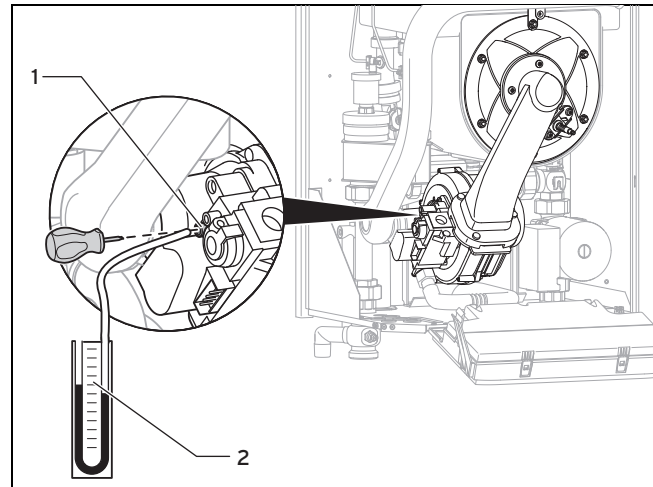

3. Undo the sealing screw (1) that is marked with **in** on the gas valve.
4. Connect a digital pressure gauge or U-tube manometer (2).
5. Open the gas isolator cock.
6. Start up the product with the check programme **P.1**.
7. In addition, ensure that maximum heat can be dissipated into the heating system by turning up the room thermostat.
8. With the boiler operating at full load check that the gas inlet working pressure at the reference test point (1) complies with the requirements.
 - Permissible gas flow pressure for operation with G20 natural gas: 1.6 ... 2.3 kPa (16.0 ... 23.0 mbar)
9. Should the pressure recorded at the reference test point in the boiler be lower than indicated check if there is any blockage in the pipework or if the pipework is undersized.

Conditions: Gas flow pressure not in the permissible range



Caution.

Risk of material damage and operating faults caused by incorrect gas flow pressure.

If the gas flow pressure lies outside the permissible range, this can cause operating faults in and damage to the product.

- ▶ Do not make any adjustments to the product.
- ▶ Check the gas installation.
- ▶ Do not start up the product.

- ▶ If you cannot correct the failure, notify the gas supply company and proceed as follows:
- ▶ End the check programme **P.01**.
- ▶ Allow the boiler to cool down by allowing pump overrun to operate for a minimum of two minutes.
- ▶ Close the gas isolator cock.

- ▶ Remove the pressure gauge and retighten the sealing screw (1) for the measuring nipple.
- ▶ Open the gas isolator cock.
- ▶ Check the measuring nipple for gas tightness.
- ▶ Close the gas isolator cock.
- ▶ Install the front casing. (→ Page 10)
- ▶ Disconnect the product from the power mains.
- ▶ You must not start up the boiler.

Conditions: Gas flow pressure in the permissible range

- ▶ End the check programme **P.01**.
- ▶ Allow the boiler to cool down allowing pump overrun to operate for a minimum of two minutes.
- ▶ Close the gas isolator cock.
- ▶ Remove the pressure gauge and retighten the sealing screw (1) for the measuring nipple.
- ▶ Open the gas isolator cock.
- ▶ Check the measuring nipple for gas tightness.
- ▶ Install the front casing. (→ Page 10)
- ▶ Reset boiler controls for normal operation.
- ▶ Record the appliance gas inlet working pressure (kPa resp. mbar) in the Benchmark gas boiler commissioning checklist.

6.12.5 Checking the CO₂ content and, if necessary, adjusting it (air index setting)

1. Start up the product with the check programme **P.1**.
2. Wait at least five minutes until the product reaches its operating temperature.

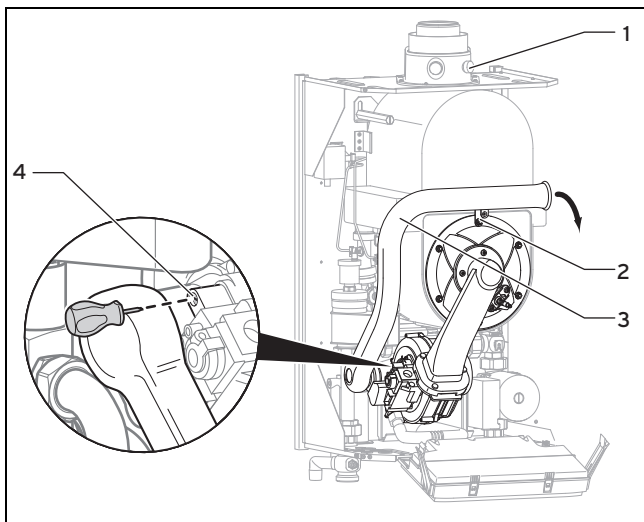

3. Measure the CO₂ content at the flue gas analysis point (1).
4. Compare the measured value with the corresponding value in the table.

Settings	Unit	G20 natural gas
CO ₂ after 5 minutes in full load mode with front casing closed	Vol.-%	9.2 ± 1.0
CO ₂ after 5 minutes in full load mode with front casing removed	Vol.-%	9.0 ± 1.0
Set for Wobbe index W ₀	kWh/m ³	14.1
O ₂ after 5 minutes in full load mode with front casing closed	Vol.-%	4.53 ± 1.8

Conditions: The CO₂ content must be adjusted

- ▶ Unscrew the screw (2) and tilt the air intake pipe (3) forwards by 90°. Do not remove the air intake pipe.
- ▶ Set the CO₂ content (value with front casing removed) by turning the screw (4).



Note

Turn to the left: Higher CO₂ content
Turn to the right: Lower CO₂ content

- ▶ Only carry out the adjustment in increments of 1/8 turn and wait approximately 1 minute after each adjustment until the value stabilises.
- ▶ After performing the adjustments, tilt the air intake pipe back up.
- ▶ Check the CO₂ content again.
- ▶ If necessary, repeat the setting process.
- ▶ Press the  button. Full load mode is also exited if no buttons are pressed for 15 minutes.
- ▶ Use the screw (2) to secure the air intake pipe again.
- ▶ If an adjustment is not possible in the specified adjustment range, you must not start up the product.
- ▶ If this is the case, inform Vaillant Customer Service.
- ▶ Install the front casing. (→ Page 10)

6.12.6 Checking the CO₂ content and, if necessary, adjusting it (air index setting)

1. Start up the product with the check programme **P.1**.
2. Wait at least five minutes until the product reaches its operating temperature.

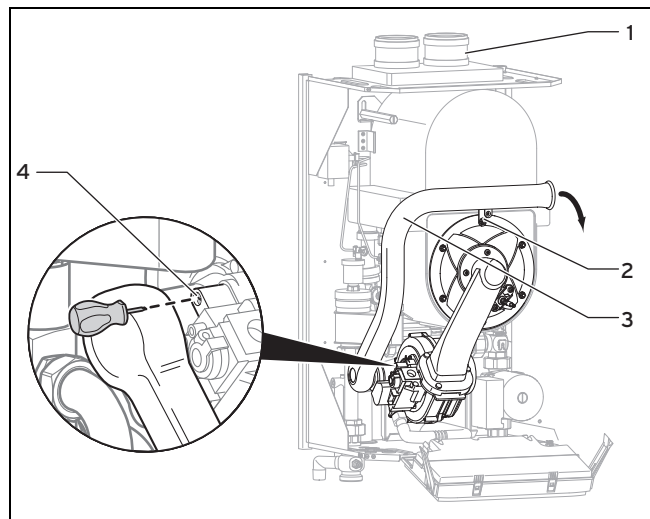

3. Measure the CO₂ content at the flue gas analysis point (1).
4. Compare the measured value with the corresponding value in the table.

Settings	Unit	G20 natural gas
CO ₂ after 5 minutes in full load mode with front casing closed	Vol.-%	9.2 ± 1.0
CO ₂ after 5 minutes in full load mode with front casing removed	Vol.-%	9.0 ± 1.0
Set for Wobbe index W ₀	kWh/m ³	14.1

6 Start-up

Settings	Unit	G20 natural gas
O ₂ after 5 minutes in full load mode with front casing closed	Vol.-%	4.53 ± 1.8

Conditions: The CO₂ content must be adjusted

- ▶ Unscrew the screw (2) and tilt the air intake pipe (3) forwards by 90°. Do not remove the air intake pipe.
- ▶ Set the CO₂ content (value with front casing removed) by turning the screw (4).



Note

Turn to the left: Higher CO₂ content
Turn to the right: Lower CO₂ content

- ▶ Only carry out the adjustment in increments of 1/8 turn and wait approximately 1 minute after each adjustment until the value stabilises.
- ▶ After performing the adjustments, tilt the air intake pipe back up.
- ▶ Check the CO₂ content again.
- ▶ If necessary, repeat the setting process.
- ▶ Press the  button. Full load mode is also exited if no buttons are pressed for 15 minutes.
- ▶ Use the screw (2) to secure the air intake pipe again.
- ▶ If an adjustment is not possible in the specified adjustment range, you must not start up the product.
- ▶ If this is the case, inform Vaillant Customer Service.
- ▶ Install the front casing. (→ Page 10)

6.13 Checking leak-tightness

- ▶ Check the gas pipe, the heating circuit and the hot water circuit for leak-tightness.
- ▶ Check that the flue gas pipe has been installed correctly.

6.13.1 Checking the heating mode

1. Make sure that there is a heat requirement.
2. Press  to activate the status display.
 - ◁ If the product is working correctly, the display shows **S.4**.

6.13.2 Checking the hot water generation

Conditions: Cylinder connected



Danger!

Risk of death from Legionella.

Legionella multiply at temperatures below 60 °C.

- ▶ Ensure that the operator is familiar with all of the Anti-legionella measures in order to comply with the applicable regulations regarding legionella prevention.

- ▶ Make sure that the cylinder thermostat is requesting heat.

1. Press  to activate the status display.

- ◁ If the cylinder is charged correctly, the display shows **S.24**.

2. If you have connected a controller which can be used to set the hot water temperature, set the hot water temperature on the boiler to the maximum possible temperature.

Conditions: Water hardness: > 3.57 mol/m³, Boiler with cylinder

- Water temperature: ≤ 50 °C
3. Adjust the target temperature for the connected domestic hot water cylinder to the controller.
 - ◁ The boiler adopts the set target temperature which is set on the controller (automatic calibration in newer controllers).

6.14 Thoroughly flushing the heating installation ("hot")

1. Operate the appliance until the boiler and the heating system are up to temperature.
2. Check the heating system for leaks.
3. Connect a hose to the drain valve located at the lowest position of the heating system.
4. Shut off the boiler, open the drain valve and all purge valves on the radiators and allow the water to flow out of the heating system and the boiler quickly and fully.
5. Close the drain valve.
6. Fill the heating system again with water as described in "Filling and purging the heating installation" (→ Page 18).
7. Re-fill the system until the system design pressure of 0,1 MPa (1,0 bar) is attained.



Note

The actual reading on the digital pressure gauge should ideally be 0,05 MPa (0,5 bar) plus an additional pressure corresponding to the highest point of the system above the base of the boiler – 10 m head equals an additional 1 bar reading on the pressure gauge. The minimum pressure should not be less than 0,1 MPa (1 bar) in any installation. If the system is to be treated with an inhibitor it should be applied at this stage in accordance with the manufacturer's instructions. Further information can be obtained from Sentinel, Betz Dearborn Ltd., Tel: 0151 420 9595, or Fernox, Alpha– Fry technologies. Tel: 0870 8700362.

8. Install the front casing. (→ Page 10)

7 Adapting the unit to the heating installation

7.1 Calling up diagnostics codes

You can use the parameters that are marked as adjustable in the overview of diagnostics codes to adapt the product to the heating installation and the needs of the customer.

Overview of diagnostics codes (→ Page 31)

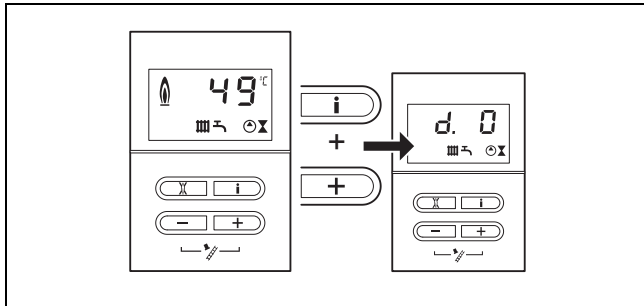

- ▶ Press **i** and **+** below the display at the same time.
 - ◁ The display shows **D.0** (heating partial load).

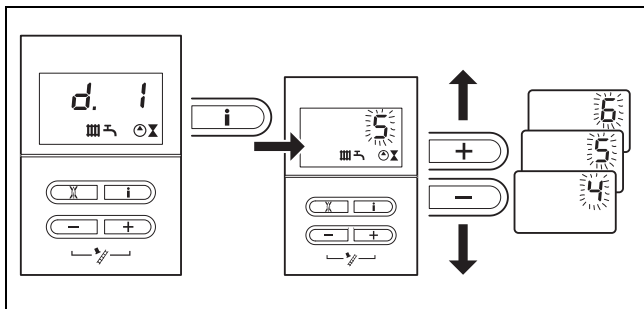

- ▶ Press **i**.
 - ◁ The display shows the associated diagnostics information.
- ▶ If required, use **+** or **-** to change the value (the display flashes).

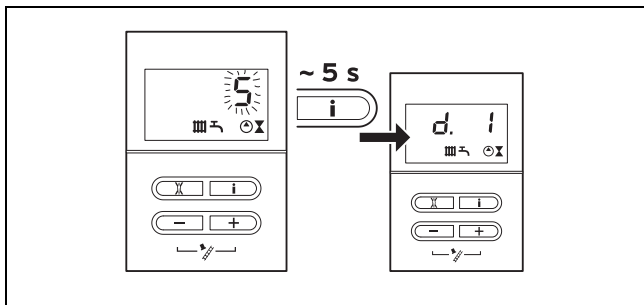

- ▶ Save the new value by pressing and holding **i** for approx. five seconds until the display no longer flashes.

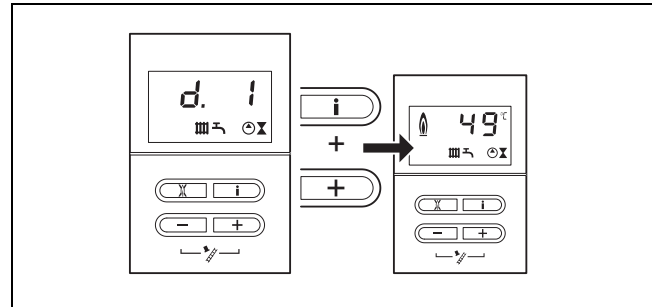

- ▶ Exit Diagnostics mode by pressing **i** and **+** at the same time or by not pressing any button for four minutes.
 - ◁ The current heating flow temperature appears in the display.



Note

If you activate the installer level (second diagnostics level), all of the diagnostics codes are visible and accessible.

7.2 Calling up the installer level (second diagnostics level)

- ▶ In the first diagnostics level, scroll to **D.97**.
- ▶ Change the displayed value to 17 (password).
- ▶ Save the setting.

7.3 Setting the heating partial load

The product's heating partial load is set to 46 kW at the factory. You can specify a value that corresponds to the product output in kW under diagnostics code **D. 0**.

7.4 Setting the pump overrun and pump operating mode

You can set the pump overrun under **D.1** (default setting: 5 min.).

You can set the overrun behaviour of the pump to a different mode under **D.18**.

Overrun: After ending the heating demand, the pump overruns the time that is set under **D.1**.

Continuous: The pump is switched on if the rotary knob for setting the heating flow temperature is not at the left-hand stop and the heat requirement is enabled by an external controller.

Intermittent: This pump operating mode is useful for removing residual heat after charging when the heat demand is extremely low and large temperature differences exist between the cylinder charging and heating mode target values. This prevents the living rooms from overheating. If there is a heat demand, the pump is switched on every 25 minutes for 5 minutes once the overrun time has elapsed.

7 Adapting the unit to the heating installation

7.5 Setting the maximum flow temperature

You can set the maximum flow temperature for the heating mode under **D.71** (default setting: 75 °C).

7.6 Setting the burner anti-cycling time

To prevent frequent switching on and off of the burner and thus prevent energy losses, an electronic restart lockout is activated for a specific period each time the burner is switched off. You can adjust the burner anti-cycling time to the conditions of the heating installation. The burner anti-cycling time is only active for the heating mode. Hot water handling mode during a burner anti-cycling time does not affect the time function element. You can set the maximum burner anti-cycling time under **D.2** (default setting: 20 min.). The effective burner anti-cycling times with respect to the target flow temperature and the maximum set burner anti-cycling time can be found in the following table:

T _{Flow} (target) [°C]	Set maximum burner anti-cycling time [min]						
	1	5	10	15	20	25	30
30	2.0	4.0	8.5	12.5	16.5	20.5	25.0
35	2.0	4.0	7.5	11.0	15.0	18.5	22.0
40	2.0	3.5	6.5	10.0	13.0	16.5	19.5
45	2.0	3.0	6.0	8.5	11.5	14.0	17.0
50	2.0	3.0	5.0	7.5	9.5	12.0	14.0
55	2.0	2.5	4.5	6.0	8.0	10.0	11.5
60	2.0	2.0	3.5	5.0	6.0	7.5	9.0
65	2.0	1.5	2.5	3.5	4.5	5.5	6.5
70	2.0	1.5	2.0	2.5	2.5	3.0	3.5
75	2.0	1.0	1.0	1.0	1.0	1.0	1.0

T _{Flow} (target) [°C]	Set maximum burner anti-cycling time [min]					
	35	40	45	50	55	60
30	29.0	33.0	37.0	41.0	45.0	49.5
35	25.5	29.5	33.0	36.5	40.5	44.0
40	22.5	26.0	29.0	32.0	35.5	38.5
45	19.5	22.5	25.0	27.5	30.5	33.0
50	16.5	18.5	21.0	23.5	25.5	28.0
55	13.5	15.0	17.0	19.0	20.5	22.5
60	10.5	11.5	13.0	14.5	15.5	17.0
65	7.0	8.0	9.0	10.0	11.0	11.5
70	4.0	4.5	5.0	5.5	6.0	6.5
75	1.0	1.0	1.0	1.0	1.0	1.0



Note

The remaining burner anti-cycling time following a regular shutdown in heating mode can be called up under **D.67**.

7.7 Setting the maintenance interval

If you set the maintenance interval, the maintenance message **SEr** appears in the display after a configurable number of burner operating hours. The display on the eBUS controller shows the information **Maintenance**.

- Use **D.84** to set the operating hours until the next maintenance work is due. Guideline values can be found in the following table.

Heat demand	Number of persons	Burner operating hours until the next inspection/maintenance work is due (dependent upon the system type)
5.0 kW	1 - 2	1050 h
	2 - 3	1150 h
10.0 kW	1 - 2	1500 h
	2 - 3	1600 h
15.0 kW	2 - 3	1800 h
	3 - 4	1900 h
20.0 kW	3 - 4	2600 h
	4 - 5	2700 h
25.0 kW	3 - 4	2800 h
	4 - 6	2900 h
> 27.0 kW	3 - 4	3000 h
	4 - 6	3000 h

The values stated correspond to an average operating time of one year.

If you do not set a numerical value but do set the symbol "-", the **Maintenance display** function is not active.



Note

On completion of the set operating hours, you must set the maintenance interval again.

7.8 Pump diagram

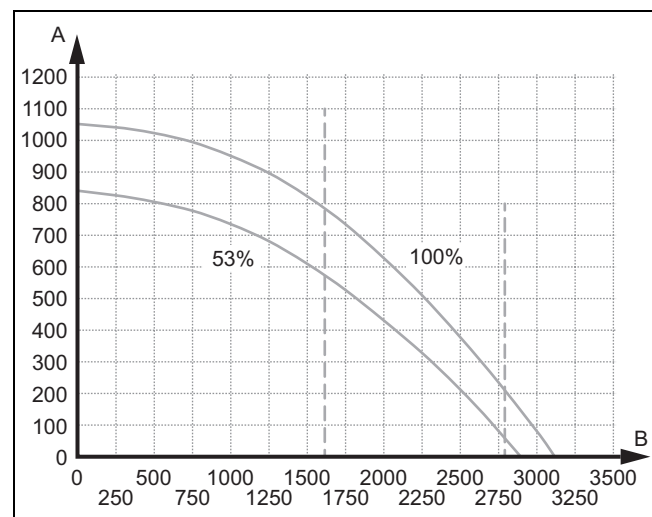

A Pump remaining feed

B System volume flow in l/h

Min. vortex and rated volume flow (ΔT 20 K) are marked.

7.9 Adjusting the product to large flue gas pipe lengths

At flue gas pipe lengths greater than 10 m (system 80/125), you can increase the product's fan speed.

- ▶ Increase the value by 20 under **D.51**.
 - ◁ The maximum speed of the fan is increased by 200 rpm.

7.10 Handing the product over to the operator

1. When you have finished the installation, attach the sticker supplied (835593) to the front of the product in the operator's language.
2. Explain to the operator how the safety devices work and where they are located.
3. Inform the operator how to handle the product. Answer any questions the operator may have. In particular, draw attention to the safety information which the operator must follow.
4. Inform the operator of the necessity to have the product maintained according to the specified intervals.
5. Pass all of the instructions and documentation for the product to the operator for safe-keeping.
6. Inform the operator about measures taken to ensure the supply of combustion air and flue gas guiding, and instruct the operator that he must not make any changes.

8 Inspection and maintenance

- ▶ Carry out all inspection and maintenance work in the order shown in the table "Overview of inspection and maintenance work".

8.1 Observing inspection and maintenance intervals



Warning.

Risk of injury and a risk of material damage caused by negligent inspection and maintenance work.

Negligence in inspection and maintenance work, as well as failure to comply with the specified inspection and maintenance intervals, may impair the operational safety of the product and lead to injuries and material damage.

- ▶ Instruct the operator that the prescribed inspection and maintenance intervals must be complied with as a minimum requirement.
- ▶ Carry out a regular inspection once a year.
- ▶ Carry out regular maintenance work in line with the findings from the inspection. The maintenance interval must not be longer than two years.



Warning.

Risk of injury and death due to improper inspection and maintenance!

Improper performance of inspections and maintenance work may result in leaks or even an explosion.

- ▶ Inspection and maintenance work on the product must only be carried out by professionally qualified persons.

Any customer service work must be carried out by a professionally qualified person in accordance with the safety, installation and operating provisions for gas-fired units. Professional qualification must be confirmed by an adequately recognised organisation or public office.



Note

The person who carries out a combustion measurement must be trained in the use of a flue gas measuring instrument and in interpreting the results. The flue gas measuring instrument that is used must be calibrated in accordance with the specifications of the measuring instrument manufacturer. The correct fuel type must be set on the flue gas measuring instrument.

Maintenance

Maintenance is required in order to eliminate any deviations of the actual condition from the target condition. This is normally done by cleaning, setting and, if necessary, replacing individual components that are subject to wear.

As the competent person, you determine the maintenance intervals (at least once every two years) and their scope based on the how you define the condition of the product during the inspection. Carry out all inspection and maintenance work in the sequence shown in Appendix C.

Proper, regular inspection and maintenance, and the exclusive use of original spare parts are absolutely essential to ensure fault-free operation and a long working life for the product.

Inspection

The inspection is intended to determine the actual condition of the product and compare it with the target condition. This is done by measuring, checking and observing.

Maintenance

Maintenance is required in order to eliminate any deviations of the actual condition from the target condition. This usually involves cleaning, adjusting and, if required, replacing individual components that are prone to wear (e.g. the burner flange seal (article number 180904), the burner insulation on the burner flange (article number 180913) and the burner insulation on the back wall of the heat exchanger (article number 0020093190)).

8 Inspection and maintenance

8.2 Procuring spare parts

The original components of the product were also certified by the manufacturer as part of the declaration of conformity. If you use other, non-certified or unauthorised parts during maintenance or repair work, this may void the conformity of the product and it will therefore no longer comply with the applicable standards.

We strongly recommend that you use original spare parts from the manufacturer as this guarantees fault-free and safe operation of the product. To receive information about the available original spare parts, contact the contact address provided on the reverse of these instructions.

- ▶ If you require spare parts for maintenance or repair work, use only the spare parts that are permitted for the product.

8.3 Removing the compact thermal module



Danger!
Risk of death and risk of material damage caused by hot flue gas.

The seal, burner insulation and self-locking nuts on the burner flange must not be damaged. Otherwise, hot flue gases may escape and cause personal injury and material damage.

- ▶ Replace the seal each time you open the burner flange.
- ▶ Replace the self-locking nuts on the burner flange each time you open the burner flange.
- ▶ If the burner insulation on the heat exchanger's burner flange shows signs of damage, replace the burner insulation.
- ▶ Replace the burner insulation on the back wall after each time the burner flange is opened.



Note
The compact thermal module consists of four main components:

- Speed-regulated fan,
- Gas-air mixture fitting,
- Gas supply (mixture pipe) to the premix burner,
- Premix burner.

1. Use the main switch to switch off the product.
2. Close the gas isolator cock.
3. Remove the front casing. (→ Page 10)
4. Tilt the electronics box forward.

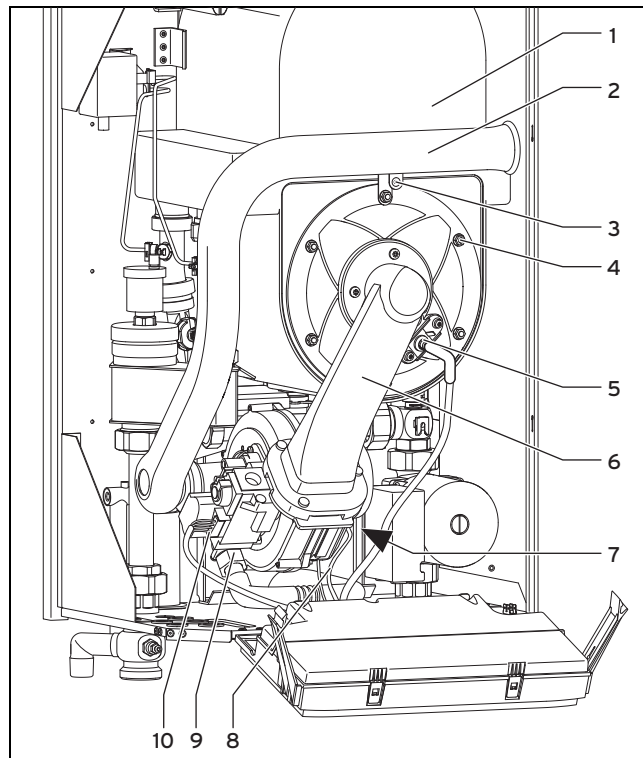

5. Unscrew the retaining screw (3).
6. Tilt the air intake pipe (2) forwards.
7. Remove the air intake pipe from the intake manifold.
8. Remove the ignition line and ground connection plugs from the ignition electrode (5).
9. Disconnect the gas line (9) from the underside of the gas valve.
10. Pull out the cable (7) from the fan motor, the PWM signal cable from the underside of the fan (8) and the cable to the gas valve (10).
11. Unscrew the six nuts (4).
12. Remove the entire compact thermal module (6) from the heat exchanger (1).
13. Check the burner and the heat exchanger for damage and dirt.
14. If necessary, clean or replace the components according to the following sections.
15. Replace the burner insulation on the back wall of the heat exchanger.
16. Check the burner insulation on the burner flange. If you notice any signs of damage, replace the burner insulation.

8.4 Cleaning the heat exchanger

1. Protect the folded down electronics box against sprayed water.

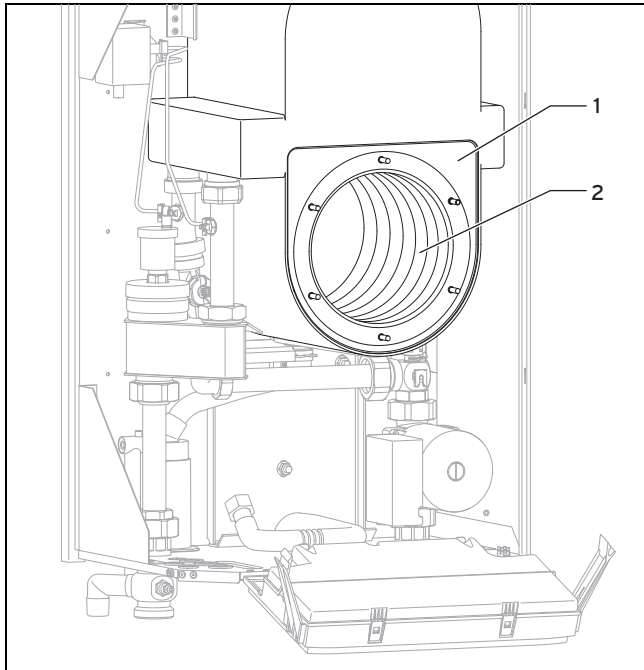

2. Use vinegar (max. 5% acid) to clean the heating coils (2) on the heat exchanger (1).
3. After a reaction time of 20 minutes, use a sharp jet of water or a plastic brush to rinse the loosened dirt. Do not point the water jet directly at the burner insulation on the back of the heat exchanger.
 - ◁ The water flows out of the heat exchanger through the condensate trap.

8.5 Descaling the heat exchanger

1. Drain the product. (→ Page 28)
2. Remove the automatic air vent from the air separator.
3. Fill the product with descaler (ET 990098) via the open connection on the automatic air vent.
4. Fill the product with clean water up to the nominal pressure.
5. Set the pump to "Continuous".
6. Use the chimney sweep button to heat up the product.
7. Leave the descaler to work in maximum output operation for approx. 30 minutes.
8. Then thoroughly rinse out the product with clean water.
9. Set the pump back to its starting condition.
10. Open the service valves and, if required, fill the heating installation.

8.6 Checking the burner

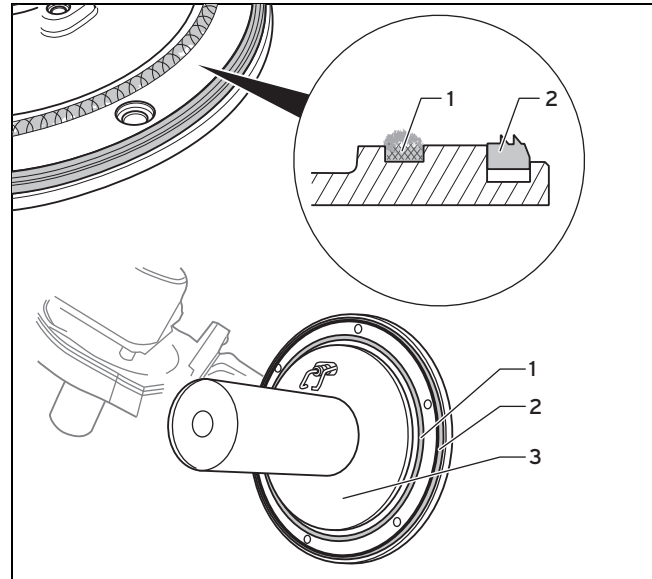

1. Check the surface of the burner for damage. If you see any damage, replace the burner.
2. Replace the silicone seal (1) and the silicate cord (2).
3. Check the burner insulation (3) on the burner flange and, if required, replace the burner insulation.

8.7 Cleaning the condensate duct

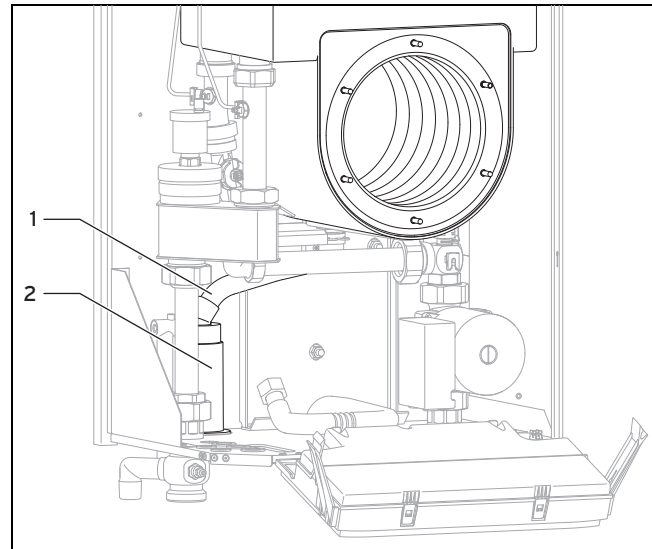

1. Observe the installation manual for the condensate trap's cartridge.
2. Remove the condensate trap's cartridge from below the product.
3. Pull out the clamp from below the heat exchanger.
4. Remove the elbow connector.
5. Remove the condensate trap (2) and the corrugated pipe (1). In doing so, note the position of the latching lugs.
6. Clean the condensate trap, the corrugated pipe and the condensate trap's cartridge.
7. Fill the condensate trap's cartridge with water.
8. Install the components with new seals and six new, self-locking nuts.

8 Inspection and maintenance

- Tightening torque: 6 Nm

8.8 Cleaning the air separation system

8.8.1 Cleaning or replacing the filter in the air separator

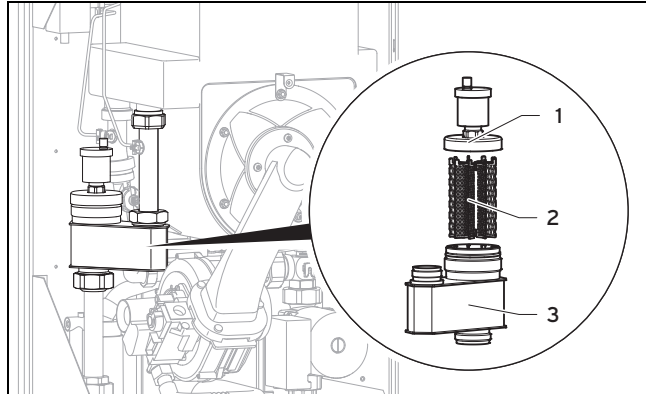

1. Unscrew the brass cover (1) on the steel casing (3).
2. Pull the filter (2) up and out.
3. Use hot water to clean the filter, or replace the filter.
4. Insert the filter into the air separator.
5. Screw in the brass cover tightly.

8.8.2 Cleaning the air separator

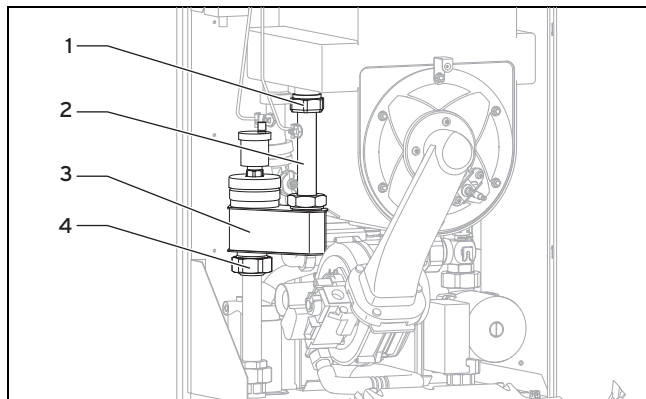

1. Unscrew the nut (4).
2. Unscrew the cap nut (1).
3. Remove the cable harness.
4. Slide the casing (3) forwards and pull the entire air separator forwards and out.
5. If required, remove the pipe (2).
6. Remove the filter.
7. Use hot water to clean the air separator and the filter.
8. Replace all of the O-rings.
9. Reinstall the air separator.

8.9 Installing the compact thermal module

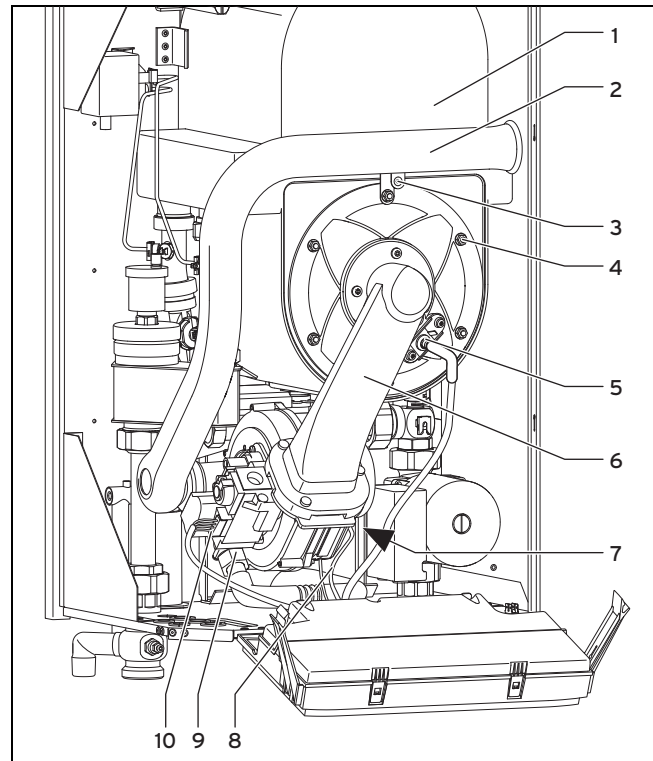

1. Connect the compact thermal module (6) to the heat exchanger (1).
2. Tighten the six nuts (4), including the retainer for the air intake pipe, in a cross-wise pattern until the burner flange fits closely and uniformly onto the mating surfaces.
3. Check that the blue sealing ring in the air intake pipe is positioned correctly in the seal seat.
4. Place the air intake pipe (2) on the intake manifold, and tighten the screw (3).
5. Connect the ignition line and the ground connection to the ignition electrode (5).
6. Insert the cable (7) from the fan motor, the PWM signal cable on the underside of the fan (8) and the cable to the gas valve (10).
7. Connect the gas line (9) using a new seal. In the process, secure the gas pipe against twisting.
8. Open the gas isolator cock.
9. Make sure that there are no leaks.

8.10 Draining the product

1. Close the service valves of the product.
2. Open the drain valves on the service valves.
3. Ensure that the automatic air vent cap on the air separator is open so that the product can be drained fully.

8.11 Checking the pre-charge pressure of the external expansion vessel

1. Depressurise the heating installation.
2. Measure the pre-charge pressure of the expansion vessel at the vessel valve.
3. Fill the expansion vessel with air at a pre-charge pressure of less than 0.075 (0.75 bar) according to the static head of the heating installation.
4. If water escapes from the valve of the expansion vessel, you must replace the expansion vessel.

8.12 Completing inspection and maintenance work

- ▶ Check the CO₂ content and, if necessary, adjust it (air index setting). (→ Page 21)
- ▶ Check the CO₂ content and, if necessary, adjust it (air index setting). (→ Page 21)
- ▶ If required, reset the maintenance interval (→ Page 24).

8.13 Checking the product for leak-tightness

- ▶ Check that the product is leak-tight. (→ Page 22)

9 Troubleshooting

You can find an overview of the fault codes in the appendix.

Overview of fault codes (→ Page 35)

9.1 Contacting your service partner

If you contact your service partner, if possible, please mention

- the fault code that is displayed (**F.xx**),
- the product status (**S.xx**) that is displayed.

9.2 Calling up status codes

You can find an overview of the status codes in the appendix.

Status codes – Overview (→ Page 34)

- ▶ To call up the display of the status codes, press **i**.
 - ◁ The display shows the status code, e.g. **S.4** for "Burner mode: Heating".
- ▶ To exit the status codes display, press **i** or do not press any button for approximately four minutes.
 - ◁ Depending on the settings, the current flow temperature or current water pressure of the heating installation reappears in the display.

9.3 Reading off the fault codes

If a fault develops in the product, the display shows a fault code **F.xx**.

Fault codes have priority over all other displays.

If multiple faults occur at the same time, the display shows the corresponding fault codes for two seconds each in sequence.

- ▶ Rectify the fault.
- ▶ To restart the product, press **X** (→ Operating instructions).
- ▶ If you are unable to rectify the fault and the fault recurs despite several reset attempts, contact Customer Service.

9.4 Querying the fault memory

The product has a fault memory. You can use this to query the last ten faults that occurred in chronological order.

- ▶ Press **i** and **←** at the same time to display the last ten faults that occurred.
 - Overview of fault codes (→ Page 35)
- ▶ Use **+** to scroll back in the fault memory.
- ▶ To exit the fault memory display, press **i** or do not press any button for approximately four minutes.
 - ◁ Depending on the settings, the current flow temperature or current water pressure of the heating installation reappears in the display.

9.5 Performing diagnostics

- ▶ You can use the diagnostics codes (→ Page 23) during fault diagnostics to change individual parameters or to display further information.

9.6 Using check programmes

- ▶ You can also use the check programmes (→ Page 16) for troubleshooting.

9.7 Resetting parameters to factory settings

- ▶ To simultaneously reset all parameters to the default settings, set **D.96** to **1**.

9.8 Preparing the repair work

1. Decommission the product.
2. Disconnect the product from the power mains.
3. Remove the front casing. (→ Page 10)
4. Close the gas isolator cock.
5. Close the service valves in the heating flow and in the heating return.
6. Close the service valve in the cold water pipe.
7. Drain the product if you want to replace water-bearing components of the product.
8. Make sure that water does not drip on live components (e.g. the electronics box).
9. Use only new seals.

10 Decommissioning the product

9.9 Replacing defective components

9.9.1 Replacing the burner

1. Remove the compact thermal module. (→ Page 26)

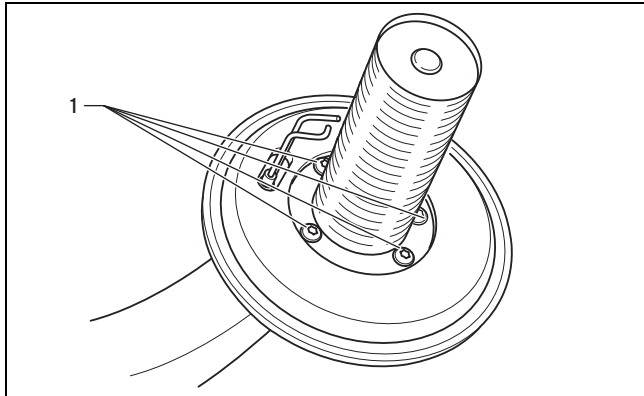

2. Remove the four screws **(1)** from the burner.
3. Remove the burner.
4. Fit the new burner with a new seal.
5. Make sure that the cutouts in the seal and the burner are situated above the burner flange sight glass.
6. Install the compact thermal module. (→ Page 28)

9.9.2 Replacing the PCB and/or the display



Note

If you are replacing only one component, the set parameters are transferred automatically. When the product is switched on, the new component adopts the previously set parameters from the unreplaced component.

1. Disconnect the product from the power mains and make sure that it cannot be switched back on again.

Conditions: Replacing the display **or** PCB

- ▶ Replace the PCB or display according to the assembly and installation instructions supplied.

Conditions: Replacing the PCB **and** display at the same time

- ▶ Replace the PCB and display according to the assembly and installation instructions supplied.
 - ◁ If you replace both components at the same time, the product switches to fault mode and displays the fault message **F.70** after it is switched on.
- ▶ In the second diagnostics level under the diagnostics code **d.93**, enter the number of the product type.
- ▶ Confirm your setting.
 - ◁ The electronics are now set to the product type and the parameters of all diagnostics codes are set to default settings.
- ▶ Make the system-specific settings.

9.10 Completing repair work

- ▶ Check that the product works correctly.

10 Decommissioning the product

- ▶ Switch off the product.
- ▶ Disconnect the product from the power mains.
- ▶ Close the gas isolator cock.
- ▶ Drain the product. (→ Page 28)

11 Recycling and disposal

Disposing of the packaging

- ▶ Dispose of the packaging correctly.
- ▶ Observe all relevant regulations.

12 Customer service

To ensure regular servicing, it is strongly recommended that arrangements are made for a Maintenance Agreement. Please contact Vaillant Service Solutions for further details:

Telephone: 0330 100 3461

Appendix

A Overview of diagnostics codes

**Note**

Since the code table is used for various products, some codes may not be visible for the product in question.

Code	Parameter	Values or explanations	Default setting	Own setting
D.0	Heating partial load, adjustable values in kW	Adjustable heating partial load	Approx. 70% of the maximum output	
D.1	Internal heating pump overrun time	2 ... 60 min	5 min	
D.2	Max. burner anti-cycling time heating at 20 °C flow temperature	2 ... 60 min	20 min	
D.4	Measured value for the cylinder temperature in °C	If a domestic hot water cylinder with sensor is connected		Not adjustable
D.5	Flow temperature target value (or return target value) in °C	Current target value, max. of the value set in D.71, restricted by an eBUS controller, if connected		Not adjustable
D.7	Target cylinder temperature	(15 °C = frost protection, 40 °C up to D.20 (max. 70 °C))		Not adjustable
D.8	Room thermostat at terminals 3-4	0 = Room thermostat open (no heat requirement) 1 = Room thermostat closed (heat requirement)		Not adjustable
D.9	Target feed temperature in °C from the external continuous controller at terminal 7-8-9/BUS	Minimum from the external BUS target value and target value for terminal 7		Not adjustable
D.10	Status of the internal heating pump	0 = Off 1 = On		Not adjustable
D.11	Status of additional external heating pump	0 = Off 1-100 = On		Not adjustable
D.12	Status of cylinder charge pump	0 = Off 1-100 = On		Not adjustable
D.13	Status of circulation pump	0 = Off 1-100 = On		Not adjustable
D.14	Setting for speed-controlled internal heating pump	0 = Auto 1 = 53 2 = 60 3 = 70 4 = 85 5 = 100 in %	0	
D.15	Current speed of the internal heating pump in %			Not adjustable
D.17	Control type	0 = Flow control 1 = Return flow temperature control	0	
D.18	Pump operating mode (overrun)	0 = Overrun 1 = Continuous 2 = Winter 3 = Intermittent	3	
D.20	Max. setting for cylinder target value	Adjustment range: 40-70 °C	65 °C	
D.22	External cylinder charging, terminal C1-C2	1 = on, 0 = off		
D.23	Summer/winter mode (heating off/on)	0 = Heating off (Summer mode) 1 = Heating on		Not adjustable
D.24	Not relevant	Not relevant		
<p>1. Five-digit numbers are saved for diagnostics codes 80 to 83. If you select D.80, for example, only the first two digits of the number will be displayed (e.g. 10). Pressing <input type="button" value="⏏"/> switches the display to the last three digits (e.g. 947). In this example, the number of operating hours for the heating is 10947 hrs. Pressing the <input type="button" value="⏏"/> again causes the display to switch back to the diagnostics code that was called up.</p>				

Appendix

Code	Parameter	Values or explanations	Default setting	Own setting
D.25	Hot water generation enabled by eBUS controller	1 = Yes, 0 = No		
D.26	Internal accessory relay at X6 (pink plug)	1 = Circulation pump 2 = Second external pump 3 = Cylinder charging pump 4 = Flue non-return flap/extractor hood 5 = External gas valve 6 = External fault message	2	
D.27	Switching accessory relay 1 for accessory "2-in-7" multi-functional module	1 = Circulation pump 2 = Second external pump 3 = Cylinder charging pump 4 = Flue non-return flap/extractor hood 5 = External gas valve 6 = External fault message	2	
D.28	Switching accessory relay 2 for accessory "2-in-7" multi-functional module	1 = Circulation pump 2 = Second external pump 3 = Cylinder charging pump 4 = Flue non-return flap/extractor hood 5 = External gas valve 6 = External fault message	3	
D.30	Control signal for gas valve	0 = Off; 1 = On		Not adjustable
D.33	Fan speed target value	in rpm/10		Not adjustable
D.34	Fan speed actual value	in rpm/10		Not adjustable
D.35	Not relevant	Not relevant		
D.40	Flow temperature	Actual value in °C		Not adjustable
D.41	Return temperature	Actual value in °C		Not adjustable
D.44	Digitalised ionisation voltage	Display field 0 to 102 >80 no flame < 40 good flame		Not adjustable
D.47	Outside temperature (with weather compensator)	Actual value in °C, if the outside temperature sensor is connected to X41		Not adjustable
D.50	Offset for minimum speed	in rpm/10, adjustment range: 0 to 300	30	
D.51	Offset for maximum speed	in rpm/10, adjustment range: -99 to 0	-45	
D.60	Number of temperature limiter shut-downs	Number of shutdowns		Not adjustable
D.61	Number of ignition device cutoffs	Number of unsuccessful ignitions in the last attempt		Not adjustable
D.64	Average ignition time	In seconds		Not adjustable
D.65	Maximum ignition time	In seconds		Not adjustable
D.67	Remaining burner anti-cycling time	In minutes		Not adjustable
D.68	Unsuccessful ignitions at 1st attempt	Number of unsuccessful ignitions		Not adjustable
D.69	Unsuccessful ignitions at 2nd attempt	Number of unsuccessful ignitions		Not adjustable
D.70	Not relevant	Not relevant		
D.71	Maximum target value heating flow temperature	40 ... 85 °C	75 °C	
<p>1. Five-digit numbers are saved for diagnostics codes 80 to 83. If you select D.80, for example, only the first two digits of the number will be displayed (e.g. 10). Pressing <input type="button" value="F1"/> switches the display to the last three digits (e.g. 947). In this example, the number of operating hours for the heating is 10947 hrs. Pressing the <input type="button" value="F1"/> again causes the display to switch back to the diagnostics code that was called up.</p>				

Code	Parameter	Values or explanations	Default setting	Own setting
D.72	Pump overrun after cylinder charging	Adjustable from 0 to 600 seconds	80 s	
D.75	Max. charging time for domestic hot water cylinder without independent control system	20 - 90 min	45 minutes	
D.76	Unit variant: Device-specific number (DSN)	.. 656/4-5 = 47		
D.77	Limit on cylinder charging output in kW	Adjustable cylinder charging output in kW	Maximum output	
D.78	Cylinder charging temperature limit (target flow temperature in cylinder charging mode) in °C	55 °C-85 °C	80 °C	
D.80	Operating hours, heating	in hrs ¹		Not adjustable
D.81	Operating hours, hot water generation	in hrs ¹		Not adjustable
D.82	Number of burner start-ups in heating mode	Number of burner start-ups /100 (3 equals 300) ¹		Not adjustable
D.83	Number of burner start-ups in hot water mode	Number of burner start-ups /100 (3 equals 300) ¹		Not adjustable
D.84	Maintenance indicator: Number of hours until the next maintenance	Adjustment range: 0 to 3000 hrs and "-" for deactivated 300 equals 3000 hrs	"-"	
D.90	Status of digital controller	0 = Not recognised (eBUS address ≤ 10) 1 = Recognised		Not adjustable
D.91	Status of DCF with external temperature sensor connected	0 = No reception 1 = Reception 2 = Synchronised 3 = Valid		Not adjustable
D.93	Product type setting (device specific number)	Setting range: 0 to 99 .. 656/4-5 = 47		
D.96	Default setting	Reset all adjustable parameters to factory setting 0 = No 1 = Yes	0	
D.97	Activating the installer level	Service code 17		
D.98	Telephone: Competent person	Programmable telephone number		
<p>1. Five-digit numbers are saved for diagnostics codes 80 to 83. If you select D.80, for example, only the first two digits of the number will be displayed (e.g. 10). Pressing <input type="button" value="↵"/> switches the display to the last three digits (e.g. 947). In this example, the number of operating hours for the heating is 10947 hrs. Pressing the <input type="button" value="↵"/> again causes the display to switch back to the diagnostics code that was called up.</p>				

B Inspection and maintenance work – Overview

The table below lists the manufacturer requirements with respect to minimum inspection and maintenance intervals. If national regulations and directives require shorter inspection and maintenance intervals, you should observe these instead of the intervals listed in the table.

No.	Work	Inspection (annual)	Maintenance (At least every two years)
1	Check the flue pipe for leak-tightness and to ensure that it is fastened correctly. Make sure that it is not blocked or damaged and has been installed in accordance with the relevant Installation Manual.	X	X
2	Check the general condition of the product. Remove dirt from the product and from the vacuum chamber.	X	X
3	Visually inspect the general condition of the compact thermal module. In doing so, pay particular attention to signs of corrosion, rust and other defects. If you notice any damage, carry out maintenance work.	X	X
4	Check the gas flow pressure at maximum heat input. If the gas flow pressure is not within the correct range, carry out maintenance work.	X	X

Appendix

No.	Work	Inspection (annual)	Maintenance (At least every two years)
5	Check the CO ₂ content (the air ratio) of the product and, if necessary, adjust it. Keep a record of this.	X	X
6	Disconnect the product from the power mains. Check that the electrical plug connections and other connections are seated correctly and correct these if necessary.	X	X
7	Close the gas isolator cock and the service valves.		X
8	Drain the product on the water side (observe the pressure gauge). Check the pre-charge pressure of the expansion vessel, and top up the vessel if necessary (approx. 0.03 MPa/0.3 bar under the system filling pressure).		X
9	Remove the compact thermal module.		X
10	Install the burner insulation on the back wall of the heat exchanger.		X
11	Clean the heat exchanger.		X
12	Replace the burner insulation (article number 0020093190) on the back wall of the heat exchanger. Replace the burner insulation each time maintenance work is carried out.		X
13	Check the burner insulation on the burner flange. If you notice any damage, replace the burner insulation (article number 180913). Replace the burner flange seal (article number 180904) each time it is opened and, accordingly, each time maintenance work is carried out.		X
14	Check the burner for damage and replace it if necessary.		X
15	Check the condensate trap in the product, and clean and fill this, if required.	X	X
16	Clean the condensate duct in the product.		X
17	Install the compact thermal module. Caution: Replace the seals (article number 130904).		X
18	Clean the air separation system.		X
19	Open the gas isolator cock, reconnect the product to the power mains and switch the product on.	X	X
20	Open the service valves, fill up the product/heating installation to 0.1-0.2 MPa/1.0-2.0 bar (depending on the static height of the heating installation) and start the purging programme P.0 .		X
21	Perform a test operation of the product and heating installation, including hot water generation, and purge the system once more if necessary.	X	X
22	Check the product's gas ratio setting and, if required, reset it. Log the setting.		X
23	Visually inspect the ignition and burner behaviour.	X	X
24	Check the CO ₂ content (the air ratio) of the product again.		X
25	Ensure that no gas, flue gas, hot water or condensate is leaking from the product. Restore leak-tightness if necessary.	X	X
26	Record the inspection/maintenance work carried out.	X	X

C Status codes – Overview

Status code	Meaning
Heating mode	
S.0	Heating: No heat demand
S.1	Heating mode: Fan start-up
S.2	Heating mode: Pump pre-run
S.3	Heating mode: Ignition
S.4	Heating mode: Burner on
S.5	Heating mode: Pump/fan overrun
S.6	Heating mode: Fan overrun
S.7	Heating mode: Pump overrun
S.8	Heating mode: Remaining anti-cycling time
Cylinder charging mode	
S.20	DHW demand
S.21	DHW mode: Fan start-up
S.22	DHW mode: Pump pre-run
S.23	DHW mode: Ignition

Status code	Meaning
S.24	DHW mode: Burner on
S.25	DHW mode: Pump/fan overrun
S.26	DHW mode: Fan overrun
S.27	DHW mode: Pump overrun
S.28	Hot water burner anti-cycling time
Special cases	
S.30	Room thermostat (RT) is blocking heating mode
S.31	Summer mode active or no heat requirement from eBUS controller
S.32	Waiting period because of fan speed deviation
S.34	Frost protection mode active
S.36	Reference setting for the continuous controller 7-8-9 or eBUS controller is < 20 °C and blocks the heating mode
S.39	Contact thermostat tripped
S.41	Water pressure > 0.28 MPa (2.8 bar)
S.42	Flue non-return flap return signal blocks burner operation (only in connection with accessories) or condensate pump faulty, heat requirement is blocked.
S.53	Product is within the waiting period of the modulation block/operation block function as a result of low water pressure (flow/return spread too large)
S.54	Product is within the waiting period of the operation blocking function as a result of low water pressure (temperature gradient)
S.59	Waiting period: Minimum volume of circulation water not achieved
S.85	Service message: "Check circulation water quantity".
S.96	Return sensor test running, heating demands are blocked.
S.97	Water pressure sensor test running, heating demands are blocked.
S.98	Flow/return sensor test running, heating demands are blocked.

D Overview of fault codes

Code	Meaning	Cause
F. 0	Flow temperature sensor interruption	NTC plug not plugged in or has come loose, multiple plug on the PCB not plugged in correctly, interruption in cable harness, NTC defective
F. 1	Return temperature sensor interruption	NTC plug not plugged in or has come loose, multiple plug on the PCB not plugged in correctly, interruption in cable harness, NTC defective
F.10	Flow NTC short circuit	NTC defective, short circuit in cable harness, cable/casing
F.11	Return NTC short circuit	NTC defective, short circuit in cable harness, cable/casing
F.13	Cylinder temperature sensor short circuit	NTC defective, short circuit in cable harness, cable/casing
F.20	Safety switch-off: Temperature limiter	Incorrect earth connection between cable harness and product, flow or return NTC defective (loose connection), black discharge via ignition cable, ignition plug or ignition electrode
F.22	Safety switch-off: Low water pressure	No or insufficient water in the product, water pressure sensor defective, cable to pump or water pressure sensor loose/not connected/defective
F.23	Safety switch-off: Temperature difference too great	Pump blocked, insufficient pump output, air in product, flow and return NTC connected the wrong way round
F.24	Safety switch-off: Temperature rise too fast	Pump blocked, insufficient pump output, air in product, system pressure too low, non-return valve blocked/incorrectly installed

Appendix

Code	Meaning	Cause
F.27	Safety switch-off: Flame simulation	Moisture on the electronics, electronics (flame monitor) defective, gas solenoid valve leaking
F.28	Failure during start-up: Ignition unsuccessful	Gas meter defective or gas pressure monitor has triggered, air in gas, gas flow pressure too low, thermal isolator device (TAE) has triggered, condensate duct blocked, incorrect gas restrictor, incorrect spare part gas valve, fault on the gas valve, multiple plug on PCB incorrectly plugged in, break in cable harness, ignition system (ignition transformer, ignition cable, ignition plug, ignition electrode) defective, ionisation current interrupted (cable, electrode), incorrect earthing of product, electronics defective
F.29	Failure during operation: Re-ignition unsuccessful	Gas supply temporarily stopped, flue gas recirculation, condensate duct blocked, defective earthing of product, ignition transformer has spark failure
F.32	Fan fault	Plug on fan not correctly plugged in, multiple plug on PCB not correctly plugged in, break in cable harness, fan blocked, Hall sensor defective, electronics defective
F.49	Fault: eBUS	Short circuit on eBUS, eBUS overload or two power supplies with different polarities on the eBUS
F.61	Gas valve actuation fault	The gas valve cannot be actuated <ul style="list-style-type: none"> – Cable harness supply line to the gas valve is defective (short to earth, short circuit) – Gas valve defective – PCB defective
F.62	Gas valve switch-off delay	Delayed shutdown of gas valve detected <ul style="list-style-type: none"> – Secondary light (ignition and monitoring electrode indicates delayed extinguishing of the flame signal) – Gas valve defective – PCB defective
F.63	Fault: EEPROM	Electronics defective
F.64	Fault: Electronics/NTC	Flow or return NTC short circuited, electronics defective
F.65	Fault: Electronics temp.	Electronics overheating due to external influences, electronics defective
F.67	Fault: Electronics/flame	Implausible flame signal, electronics defective
F.70	Invalid device specific number (DSN)	If spare parts fitted: Display and PCB replaced at same time and DSN not reset, incorrect or missing output range coding resistance
F.71	Flow NTC fault	Flow temperature sensor signalling constant value: <ul style="list-style-type: none"> – Flow temperature sensor incorrectly positioned at supply pipe – Flow temperature sensor defective
F.72	Flow/return NTC fault	Flow/return NTC temperature difference too great → flow and/or return temperature sensor defective
F.73	Water pressure sensor signal in the wrong range (too low)	Interruption/short circuit of water pressure sensor, interruption/short circuit to GND in supply line to water pressure sensor or water pressure sensor defective
F.74	Water pressure sensor signal outside correct range (too high)	Line to water pressure sensor has a short circuit to 5 V/24 V or internal fault in the water pressure sensor
F.75	Fault: No pressure change detection when starting pump	Water pressure sensor and/or pump defective, air in the heating installation, insufficient water in the product; check adjustable bypass, connect external expansion vessel to the return
F.77	Fault: Flue non-return flap/condensate pump	No response from flue non-return flap or condensate pump defective
con	No communication with the PCB	Communication fault between display and PCB in the electronics box

E Connection diagram

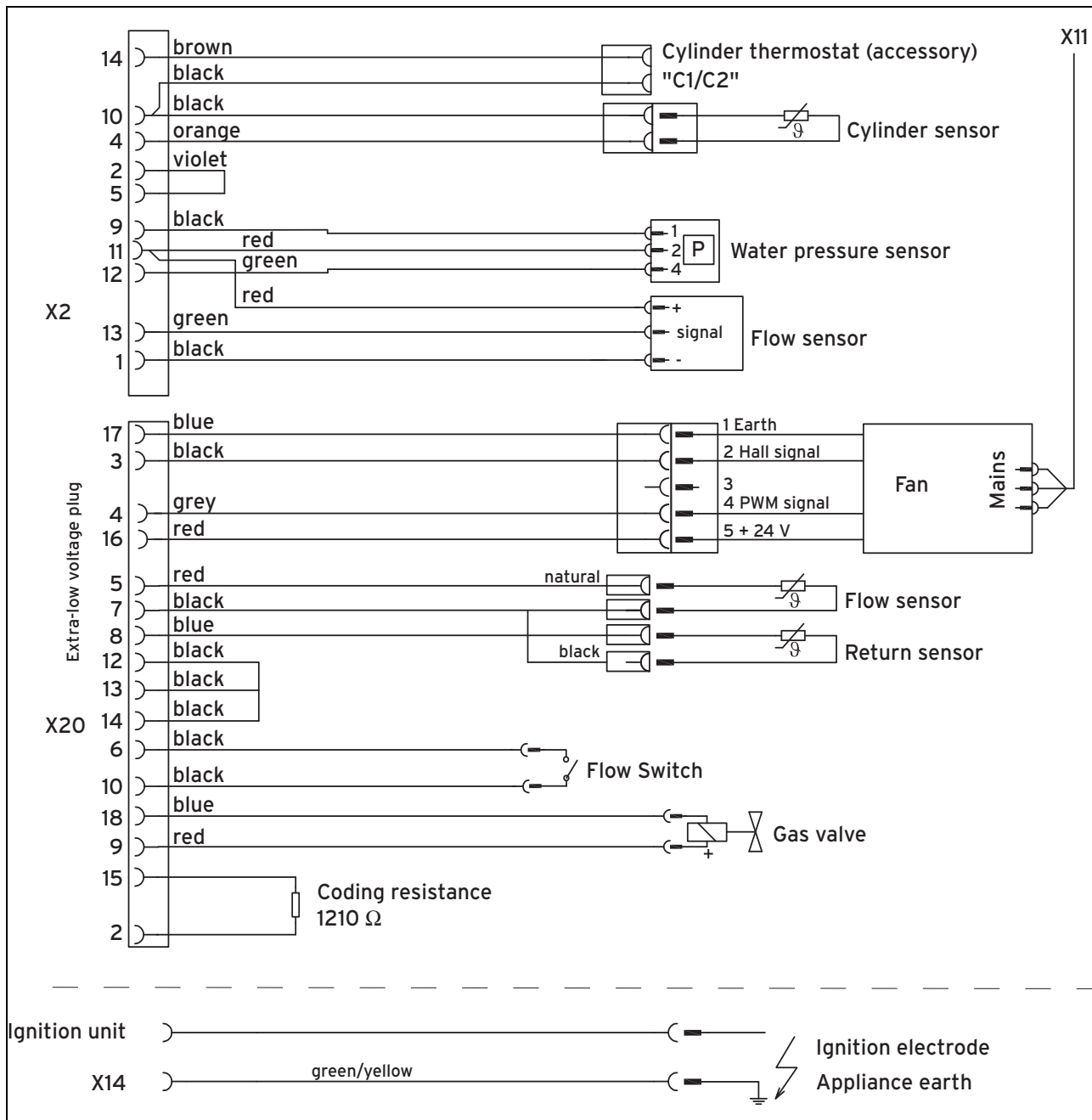

Appendix

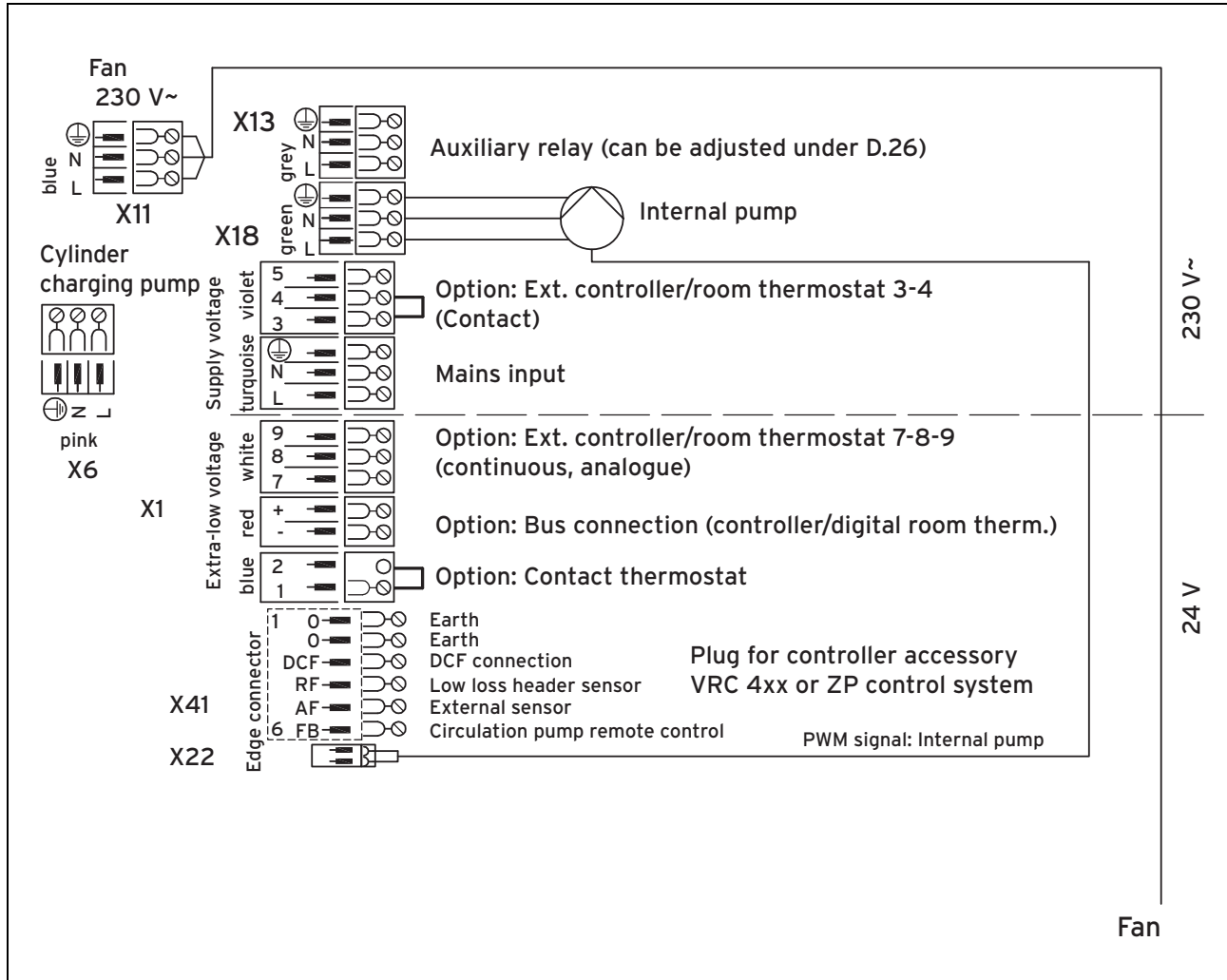

F Commissioning Checklist

Benchmark Commissioning and Servicing Section

It is a requirement that the boiler is installed and commissioned to the manufacturers instructions and the data fields on the commissioning checklist completed in full.

To instigate the boiler guarantee the boiler needs to be registered with the manufacturer within one month of the installation.

To maintain the boiler guarantee it is essential that the boiler is serviced annually by a Gas Safe registered engineer who has been trained on the boiler installed. The service details should be recorded on the Benchmark Service Interval Record and left with the householder.



www.centralheating.co.uk

Appendix

GAS BOILER SYSTEM COMMISSIONING CHECKLIST

This Commissioning Checklist is to be completed in full by the competent person who commissioned the boiler as a means of demonstrating compliance with the appropriate Building Regulations and then handed to the customer to keep for future reference.

Failure to install and commission according to the manufacturer's instructions and complete this Benchmark Commissioning Checklist will invalidate the warranty. This does not affect the customer's statutory rights.

Customer name:		Telephone number:					
Address:							
Boiler make and model:							
Boiler serial number:							
Commissioned by (PRINT NAME):		Gas Safe register number:					
Company name:		Telephone number:					
Company address:							
Commissioning date:							
To be completed by the customer on receipt of a Building Regulations Compliance Certificate*							
Building Regulations Notification Number (if applicable):							
CONTROLS (tick the appropriate boxes)							
Time and temperature control to heating	Room thermostat and programmer/timer	Programmable room thermostat					
	Load/weather compensation	Optimum start control					
Time and temperature control to hot water	Cylinder thermostat and programmer/timer	Combination Boiler					
Heating zone valves	Fitted	Not required					
Hot water zone valves	Fitted	Not required					
Thermostatic radiator valves	Fitted	Not required					
Automatic bypass to system	Fitted	Not required					
Boiler interlock		Provided					
ALL SYSTEMS							
The system has been flushed and cleaned in accordance with BS7593 and boiler manufacturer's instructions			Yes				
What system cleaner was used?							
What inhibitor was used?			Quantity litres				
Has a primary water system filter been installed?			Yes No				
CENTRAL HEATING MODE measure and record:							
Gas rate	m ³ /hr	OR	ft ³ /hr				
Burner operating pressure (if applicable)	mbar	OR Gas inlet pressure	mbar				
Central heating flow temperature	°C						
Central heating return temperature	°C						
COMBINATION BOILERS ONLY							
Is the installation in a hard water area (above 200ppm)?			Yes No				
If yes, and if required by the manufacturer, has a water scale reducer been fitted?			Yes No				
What type of scale reducer has been fitted?							
DOMESTIC HOT WATER MODE Measure and Record:							
Gas rate	m ³ /hr	OR	ft ³ /hr				
Burner operating pressure (at maximum rate)	mbar	OR Gas inlet pressure at maximum rate	mbar				
Cold water inlet temperature	°C						
Hot water has been checked at all outlets			Yes Temperature °C				
Water flow rate	l/min						
CONDENSING BOILERS ONLY							
The condensate drain has been installed in accordance with the manufacturer's instructions and/or BS5546/BS6798			Yes				
ALL INSTALLATIONS							
Record the following:	At max. rate:	CO	ppm	AND	CO/CO ₂	Ratio	
	At min. rate: (where possible)	CO	ppm	AND	CO/CO ₂	Ratio	
The heating and hot water system complies with the appropriate Building Regulations			Yes				
The boiler and associated products have been installed and commissioned in accordance with the manufacturer's instructions			Yes				
The operation of the boiler and system controls have been demonstrated to and understood by the customer			Yes				
The manufacturer's literature, including Benchmark Checklist and Service Record, has been explained and left with the customer			Yes				
Commissioning Engineer's Signature							
Customer's Signature							
(To confirm satisfactory demonstration and receipt of manufacturer's literature)							

*All installations in England and Wales must be notified to Local Authority Building Control (LABC) either directly or through a Competent Persons Scheme. A Building Regulations Compliance Certificate will then be issued to the customer.



SERVICE RECORD

It is recommended that your heating system is serviced regularly and that the appropriate Service Interval Record is completed.

Service Provider

Before completing the appropriate Service Record below, please ensure you have carried out the service as described in the manufacturer's instructions. Always use the manufacturer's specified spare part when replacing controls.

<table border="1" style="width:100%; border-collapse: collapse;"> <tr> <td colspan="2">SERVICE 01</td> <td colspan="2">Date:</td> </tr> <tr> <td colspan="4">Engineer name:</td> </tr> <tr> <td colspan="4">Company name:</td> </tr> <tr> <td colspan="4">Telephone No:</td> </tr> <tr> <td colspan="4">Gas safe register No:</td> </tr> <tr> <td>Record:</td> <td>At max. rate:</td> <td>CO ppm</td> <td>AND CO₂ %</td> </tr> <tr> <td></td> <td>At min. rate: (Where Possible)</td> <td>CO ppm</td> <td>AND CO₂ %</td> </tr> <tr> <td colspan="4">Comments:</td> </tr> <tr> <td colspan="4">Signature</td> </tr> </table>	SERVICE 01		Date:		Engineer name:				Company name:				Telephone No:				Gas safe register No:				Record:	At max. rate:	CO ppm	AND CO ₂ %		At min. rate: (Where Possible)	CO ppm	AND CO ₂ %	Comments:				Signature				<table border="1" style="width:100%; border-collapse: collapse;"> <tr> <td colspan="2">SERVICE 02</td> <td colspan="2">Date:</td> </tr> <tr> <td colspan="4">Engineer name:</td> </tr> <tr> <td colspan="4">Company name:</td> </tr> <tr> <td colspan="4">Telephone No:</td> </tr> <tr> <td colspan="4">Gas safe register No:</td> </tr> <tr> <td>Record:</td> <td>At max. rate:</td> <td>CO ppm</td> <td>AND CO₂ %</td> </tr> <tr> <td></td> <td>At min. rate: (Where Possible)</td> <td>CO ppm</td> <td>AND CO₂ %</td> </tr> <tr> <td colspan="4">Comments:</td> </tr> <tr> <td colspan="4">Signature</td> </tr> </table>	SERVICE 02		Date:		Engineer name:				Company name:				Telephone No:				Gas safe register No:				Record:	At max. rate:	CO ppm	AND CO ₂ %		At min. rate: (Where Possible)	CO ppm	AND CO ₂ %	Comments:				Signature			
SERVICE 01		Date:																																																																							
Engineer name:																																																																									
Company name:																																																																									
Telephone No:																																																																									
Gas safe register No:																																																																									
Record:	At max. rate:	CO ppm	AND CO ₂ %																																																																						
	At min. rate: (Where Possible)	CO ppm	AND CO ₂ %																																																																						
Comments:																																																																									
Signature																																																																									
SERVICE 02		Date:																																																																							
Engineer name:																																																																									
Company name:																																																																									
Telephone No:																																																																									
Gas safe register No:																																																																									
Record:	At max. rate:	CO ppm	AND CO ₂ %																																																																						
	At min. rate: (Where Possible)	CO ppm	AND CO ₂ %																																																																						
Comments:																																																																									
Signature																																																																									
<table border="1" style="width:100%; border-collapse: collapse;"> <tr> <td colspan="2">SERVICE 03</td> <td colspan="2">Date:</td> </tr> <tr> <td colspan="4">Engineer name:</td> </tr> <tr> <td colspan="4">Company name:</td> </tr> <tr> <td colspan="4">Telephone No:</td> </tr> <tr> <td colspan="4">Gas safe register No:</td> </tr> <tr> <td>Record:</td> <td>At max. rate:</td> <td>CO ppm</td> <td>AND CO₂ %</td> </tr> <tr> <td></td> <td>At min. rate: (Where Possible)</td> <td>CO ppm</td> <td>AND CO₂ %</td> </tr> <tr> <td colspan="4">Comments:</td> </tr> <tr> <td colspan="4">Signature</td> </tr> </table>	SERVICE 03		Date:		Engineer name:				Company name:				Telephone No:				Gas safe register No:				Record:	At max. rate:	CO ppm	AND CO ₂ %		At min. rate: (Where Possible)	CO ppm	AND CO ₂ %	Comments:				Signature				<table border="1" style="width:100%; border-collapse: collapse;"> <tr> <td colspan="2">SERVICE 04</td> <td colspan="2">Date:</td> </tr> <tr> <td colspan="4">Engineer name:</td> </tr> <tr> <td colspan="4">Company name:</td> </tr> <tr> <td colspan="4">Telephone No:</td> </tr> <tr> <td colspan="4">Gas safe register No:</td> </tr> <tr> <td>Record:</td> <td>At max. rate:</td> <td>CO ppm</td> <td>AND CO₂ %</td> </tr> <tr> <td></td> <td>At min. rate: (Where Possible)</td> <td>CO ppm</td> <td>AND CO₂ %</td> </tr> <tr> <td colspan="4">Comments:</td> </tr> <tr> <td colspan="4">Signature</td> </tr> </table>	SERVICE 04		Date:		Engineer name:				Company name:				Telephone No:				Gas safe register No:				Record:	At max. rate:	CO ppm	AND CO ₂ %		At min. rate: (Where Possible)	CO ppm	AND CO ₂ %	Comments:				Signature			
SERVICE 03		Date:																																																																							
Engineer name:																																																																									
Company name:																																																																									
Telephone No:																																																																									
Gas safe register No:																																																																									
Record:	At max. rate:	CO ppm	AND CO ₂ %																																																																						
	At min. rate: (Where Possible)	CO ppm	AND CO ₂ %																																																																						
Comments:																																																																									
Signature																																																																									
SERVICE 04		Date:																																																																							
Engineer name:																																																																									
Company name:																																																																									
Telephone No:																																																																									
Gas safe register No:																																																																									
Record:	At max. rate:	CO ppm	AND CO ₂ %																																																																						
	At min. rate: (Where Possible)	CO ppm	AND CO ₂ %																																																																						
Comments:																																																																									
Signature																																																																									
<table border="1" style="width:100%; border-collapse: collapse;"> <tr> <td colspan="2">SERVICE 05</td> <td colspan="2">Date:</td> </tr> <tr> <td colspan="4">Engineer name:</td> </tr> <tr> <td colspan="4">Company name:</td> </tr> <tr> <td colspan="4">Telephone No:</td> </tr> <tr> <td colspan="4">Gas safe register No:</td> </tr> <tr> <td>Record:</td> <td>At max. rate:</td> <td>CO ppm</td> <td>AND CO₂ %</td> </tr> <tr> <td></td> <td>At min. rate: (Where Possible)</td> <td>CO ppm</td> <td>AND CO₂ %</td> </tr> <tr> <td colspan="4">Comments:</td> </tr> <tr> <td colspan="4">Signature</td> </tr> </table>	SERVICE 05		Date:		Engineer name:				Company name:				Telephone No:				Gas safe register No:				Record:	At max. rate:	CO ppm	AND CO ₂ %		At min. rate: (Where Possible)	CO ppm	AND CO ₂ %	Comments:				Signature				<table border="1" style="width:100%; border-collapse: collapse;"> <tr> <td colspan="2">SERVICE 06</td> <td colspan="2">Date:</td> </tr> <tr> <td colspan="4">Engineer name:</td> </tr> <tr> <td colspan="4">Company name:</td> </tr> <tr> <td colspan="4">Telephone No:</td> </tr> <tr> <td colspan="4">Gas safe register No:</td> </tr> <tr> <td>Record:</td> <td>At max. rate:</td> <td>CO ppm</td> <td>AND CO₂ %</td> </tr> <tr> <td></td> <td>At min. rate: (Where Possible)</td> <td>CO ppm</td> <td>AND CO₂ %</td> </tr> <tr> <td colspan="4">Comments:</td> </tr> <tr> <td colspan="4">Signature</td> </tr> </table>	SERVICE 06		Date:		Engineer name:				Company name:				Telephone No:				Gas safe register No:				Record:	At max. rate:	CO ppm	AND CO ₂ %		At min. rate: (Where Possible)	CO ppm	AND CO ₂ %	Comments:				Signature			
SERVICE 05		Date:																																																																							
Engineer name:																																																																									
Company name:																																																																									
Telephone No:																																																																									
Gas safe register No:																																																																									
Record:	At max. rate:	CO ppm	AND CO ₂ %																																																																						
	At min. rate: (Where Possible)	CO ppm	AND CO ₂ %																																																																						
Comments:																																																																									
Signature																																																																									
SERVICE 06		Date:																																																																							
Engineer name:																																																																									
Company name:																																																																									
Telephone No:																																																																									
Gas safe register No:																																																																									
Record:	At max. rate:	CO ppm	AND CO ₂ %																																																																						
	At min. rate: (Where Possible)	CO ppm	AND CO ₂ %																																																																						
Comments:																																																																									
Signature																																																																									
<table border="1" style="width:100%; border-collapse: collapse;"> <tr> <td colspan="2">SERVICE 07</td> <td colspan="2">Date:</td> </tr> <tr> <td colspan="4">Engineer name:</td> </tr> <tr> <td colspan="4">Company name:</td> </tr> <tr> <td colspan="4">Telephone No:</td> </tr> <tr> <td colspan="4">Gas safe register No:</td> </tr> <tr> <td>Record:</td> <td>At max. rate:</td> <td>CO ppm</td> <td>AND CO₂ %</td> </tr> <tr> <td></td> <td>At min. rate: (Where Possible)</td> <td>CO ppm</td> <td>AND CO₂ %</td> </tr> <tr> <td colspan="4">Comments:</td> </tr> <tr> <td colspan="4">Signature</td> </tr> </table>	SERVICE 07		Date:		Engineer name:				Company name:				Telephone No:				Gas safe register No:				Record:	At max. rate:	CO ppm	AND CO ₂ %		At min. rate: (Where Possible)	CO ppm	AND CO ₂ %	Comments:				Signature				<table border="1" style="width:100%; border-collapse: collapse;"> <tr> <td colspan="2">SERVICE 08</td> <td colspan="2">Date:</td> </tr> <tr> <td colspan="4">Engineer name:</td> </tr> <tr> <td colspan="4">Company name:</td> </tr> <tr> <td colspan="4">Telephone No:</td> </tr> <tr> <td colspan="4">Gas safe register No:</td> </tr> <tr> <td>Record:</td> <td>At max. rate:</td> <td>CO ppm</td> <td>AND CO₂ %</td> </tr> <tr> <td></td> <td>At min. rate: (Where Possible)</td> <td>CO ppm</td> <td>AND CO₂ %</td> </tr> <tr> <td colspan="4">Comments:</td> </tr> <tr> <td colspan="4">Signature</td> </tr> </table>	SERVICE 08		Date:		Engineer name:				Company name:				Telephone No:				Gas safe register No:				Record:	At max. rate:	CO ppm	AND CO ₂ %		At min. rate: (Where Possible)	CO ppm	AND CO ₂ %	Comments:				Signature			
SERVICE 07		Date:																																																																							
Engineer name:																																																																									
Company name:																																																																									
Telephone No:																																																																									
Gas safe register No:																																																																									
Record:	At max. rate:	CO ppm	AND CO ₂ %																																																																						
	At min. rate: (Where Possible)	CO ppm	AND CO ₂ %																																																																						
Comments:																																																																									
Signature																																																																									
SERVICE 08		Date:																																																																							
Engineer name:																																																																									
Company name:																																																																									
Telephone No:																																																																									
Gas safe register No:																																																																									
Record:	At max. rate:	CO ppm	AND CO ₂ %																																																																						
	At min. rate: (Where Possible)	CO ppm	AND CO ₂ %																																																																						
Comments:																																																																									
Signature																																																																									
<table border="1" style="width:100%; border-collapse: collapse;"> <tr> <td colspan="2">SERVICE 09</td> <td colspan="2">Date:</td> </tr> <tr> <td colspan="4">Engineer name:</td> </tr> <tr> <td colspan="4">Company name:</td> </tr> <tr> <td colspan="4">Telephone No:</td> </tr> <tr> <td colspan="4">Gas safe register No:</td> </tr> <tr> <td>Record:</td> <td>At max. rate:</td> <td>CO ppm</td> <td>AND CO₂ %</td> </tr> <tr> <td></td> <td>At min. rate: (Where Possible)</td> <td>CO ppm</td> <td>AND CO₂ %</td> </tr> <tr> <td colspan="4">Comments:</td> </tr> <tr> <td colspan="4">Signature</td> </tr> </table>	SERVICE 09		Date:		Engineer name:				Company name:				Telephone No:				Gas safe register No:				Record:	At max. rate:	CO ppm	AND CO ₂ %		At min. rate: (Where Possible)	CO ppm	AND CO ₂ %	Comments:				Signature				<table border="1" style="width:100%; border-collapse: collapse;"> <tr> <td colspan="2">SERVICE 10</td> <td colspan="2">Date:</td> </tr> <tr> <td colspan="4">Engineer name:</td> </tr> <tr> <td colspan="4">Company name:</td> </tr> <tr> <td colspan="4">Telephone No:</td> </tr> <tr> <td colspan="4">Gas safe register No:</td> </tr> <tr> <td>Record:</td> <td>At max. rate:</td> <td>CO ppm</td> <td>AND CO₂ %</td> </tr> <tr> <td></td> <td>At min. rate: (Where Possible)</td> <td>CO ppm</td> <td>AND CO₂ %</td> </tr> <tr> <td colspan="4">Comments:</td> </tr> <tr> <td colspan="4">Signature</td> </tr> </table>	SERVICE 10		Date:		Engineer name:				Company name:				Telephone No:				Gas safe register No:				Record:	At max. rate:	CO ppm	AND CO ₂ %		At min. rate: (Where Possible)	CO ppm	AND CO ₂ %	Comments:				Signature			
SERVICE 09		Date:																																																																							
Engineer name:																																																																									
Company name:																																																																									
Telephone No:																																																																									
Gas safe register No:																																																																									
Record:	At max. rate:	CO ppm	AND CO ₂ %																																																																						
	At min. rate: (Where Possible)	CO ppm	AND CO ₂ %																																																																						
Comments:																																																																									
Signature																																																																									
SERVICE 10		Date:																																																																							
Engineer name:																																																																									
Company name:																																																																									
Telephone No:																																																																									
Gas safe register No:																																																																									
Record:	At max. rate:	CO ppm	AND CO ₂ %																																																																						
	At min. rate: (Where Possible)	CO ppm	AND CO ₂ %																																																																						
Comments:																																																																									
Signature																																																																									

*All installations in England and Wales must be notified to Local Authority Building Control (LABC) either directly or through a Competent Persons Scheme. A Building Regulations Compliance Certificate will then be issued to the customer.



Appendix

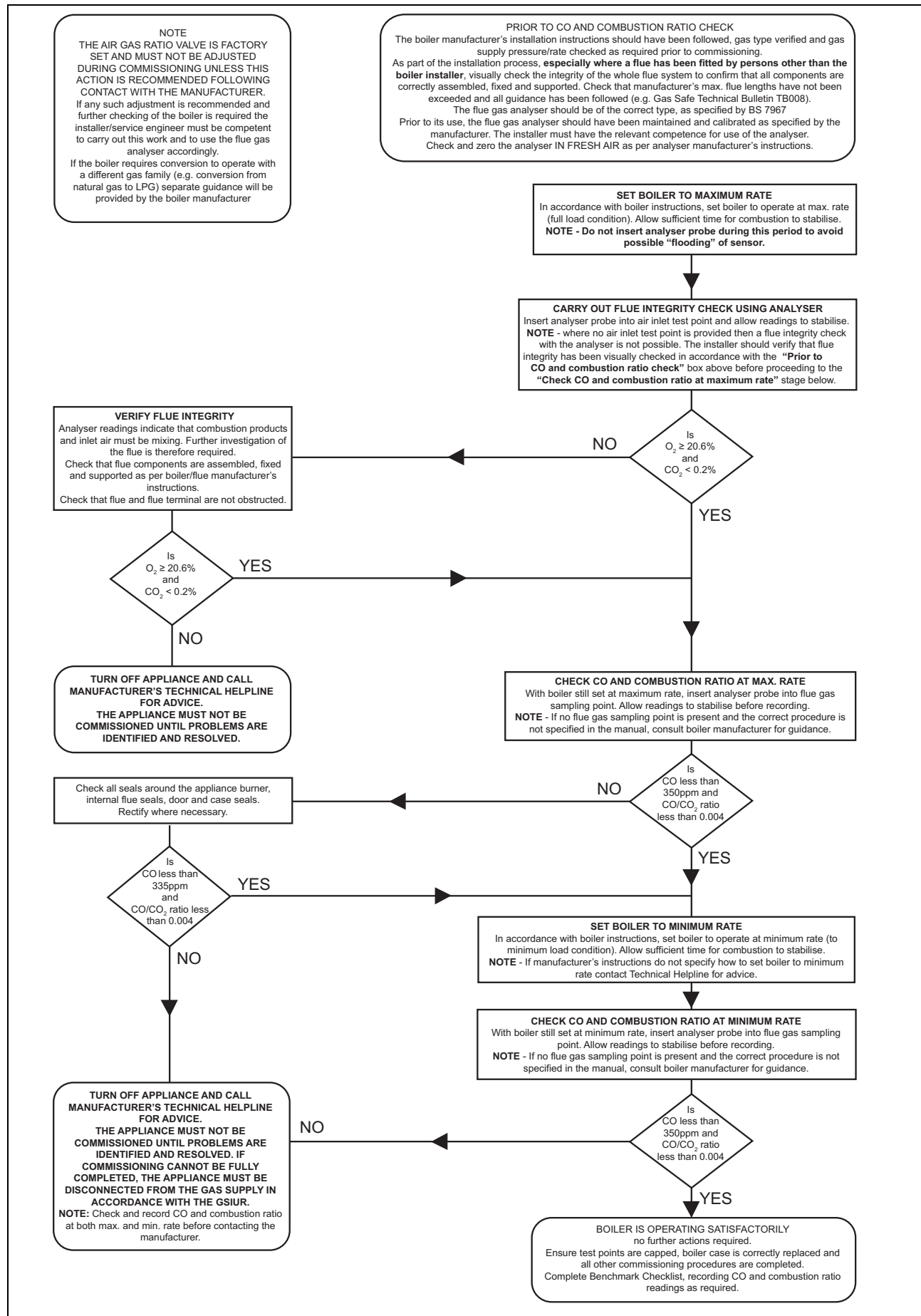

G Opening of the flue pipe

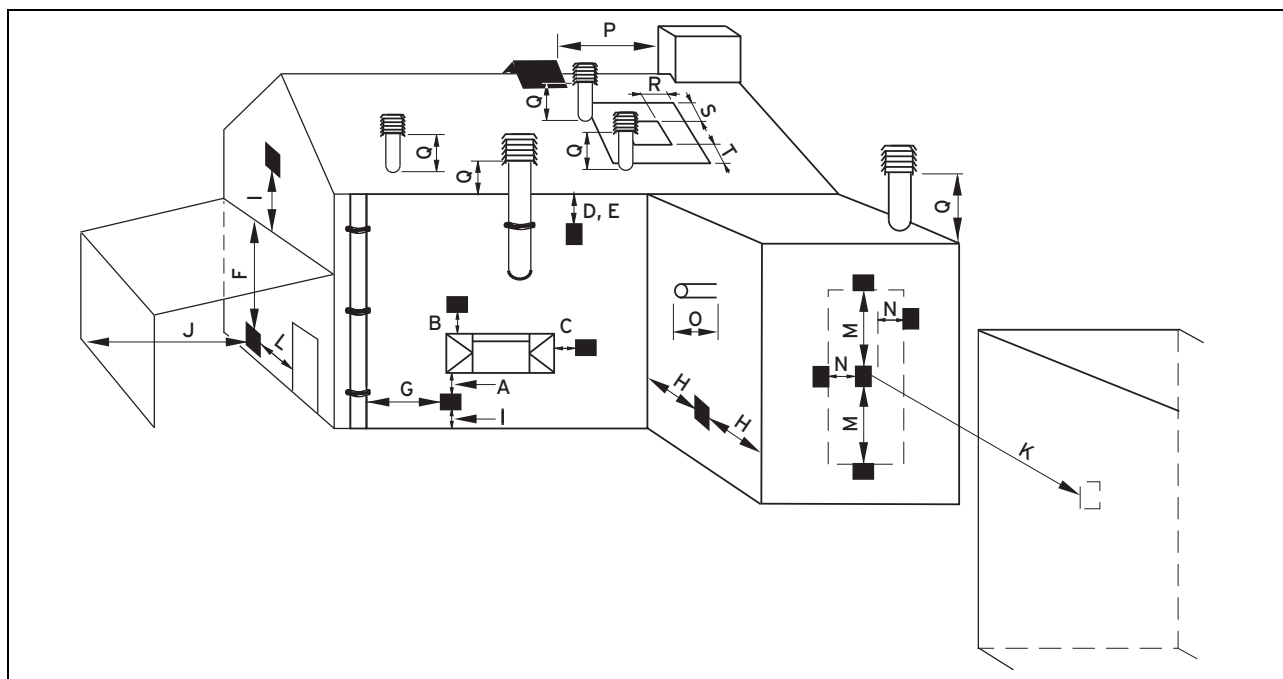

G.1 Positioning of the opening of a fan-supported flue gas guiding

	Installation site	Minimum dimensions
A	Directly below an opening, air bricks, opening windows, etc., that can be opened.	300 mm
B	Above an opening, air bricks, opening windows, etc., that can be opened.	300 mm
C	Horizontally to an opening, air bricks, opening windows, etc., that can be opened.	300 mm
D	Below temperature-sensitive building components, e.g. plastic gutters, down pipes or wastewater pipes	75 mm
E	Below eaves	200 mm
F	Below balconies or car port roofs	200 mm
G	From vertical wastewater pipes or down pipes	150 mm
H	From external or internal corners	200 mm
I	Above floors, roofs or balconies	300 mm
J	From a surface facing a terminal	600 mm
K	From a terminal facing a terminal	1200 mm
L	From an opening in the car port (e.g. door, window) which leads into the dwelling	1200 mm
M	Vertical from a terminal on the same wall	1500 mm
N	Horizontal from a terminal on the same wall	300 mm
O	From the wall on which the terminal has been installed	0 mm
P	From a vertical structure on the roof	N/A
Q	Above the roof area	300 mm
R	Horizontal from adjacent windows on pitched or flat roofs	600 mm
S	Above adjacent windows on pitched or flat roofs	600 mm
T	Below adjacent windows on pitched or flat roofs	2000 mm

Appendix

H Horizontal terminal positioning

BS 5440-1 recommends that fanned flue chimney terminals should be positioned as follows:

- a) at least 2 m from an opening in the building directly opposite, and
- b) so that the products of combustion are not directed to discharge directly across a boundary if the products are likely to cause a nuisance to a neighbour or discharge over a walkway or patio.

For IE see current issue of IS 813.

For boilers covered within this manual.

1) Dimensions D, E, F and G:

These clearances may be reduced to 25 mm without affecting the performance of the boiler. In order to ensure that the condensate plume does not affect adjacent surfaces the terminal should be extended as shown below.

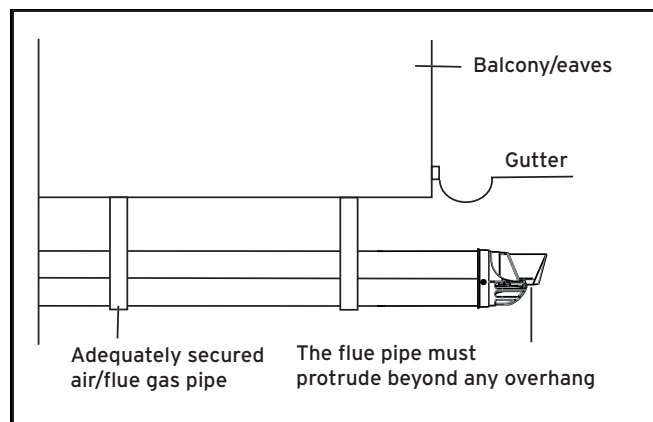

2) Dimension H:

This clearance may be reduced to 25 mm without affecting the performance of the boiler. However, in order to ensure that the condensate plume does not affect adjacent surfaces a clearance of 300 mm is preferred.

For 1 and 2 above you can use a flue gas management kit to enable the termination point to be positioned and directed away from the building fabric.

I Technical data

Technical data – Power/load

The lowest nominal heat output may be higher than the value in the technical data, depending on the design of the system and the current operating status.

	VU GB 656/4-5 A
Nominal heat output range P at 40/30 °C	14.9 ... 69.2 kW
Nominal heat output range P at 50/30 °C	14.6 ... 67.6 kW
Nominal heat output range P at 60/40 °C	14.1 ... 65.7 kW
Nominal heat output range P at 80/60 °C	13.8 ... 63.7 kW
Maximum heat input, heating side	65.0 kW
Minimum heat input heating side	14.0 kW

Technical data – Heating

	VU GB 656/4-5 A
Maximum flow temperature	90 °C
Max. flow temperature adjustment range (default setting: 75 °C)	35 ... 85 °C
Permissible total overpressure	0.3 MPa (3.0 bar)
Circulation water volume (with reference to $\Delta T = 20$ K)	2,750 l/h
Approx. condensate rate (pH value approx. 3.7) in heating mode at 40/30 °C	6.5 l/h

Technical data – cylinder charging mode

	VU GB 656/4-5 A
Maximum heat input in cylinder charging mode	65.0 kW
Cylinder charging output	Such as heating

Technical data – General

	VU GB 656/4-5 A
Gas connection, boiler side	1"
Flow/return heating connections, inside thread, boiler side	1"
Flow/return heating connections, outside thread, boiler side	1,5"
Gas connection pressure, G20 natural gas	2.0 kPa (20.0 mbar)
Gas flow at 15 °C and 1013 mbar (based on hot water generation if applicable), G20	6.9 m³/h
Min. flue gas mass rate	6.5 g/s
Max. flue gas mass rate	30.3 g/s
Min. flue gas temperature	40 °C
Max. flue gas temperature	70 °C
Permissible pressure difference in the flue gas pipe for installation type B23P as a single occupancy max.	190 Pa
Permissible pressure difference in the flue gas pipe for installation type B23P as multiple occupancy max.	50 Pa
30% efficiency	108 %
NOx class	5
Boiler dimension, width	480 mm
Boiler dimension, height	800 mm
Boiler dimension, depth	472 mm
Approx. net weight	75 kg

Technical data – Electrics

	VU GB 656/4-5 A
Rated voltage	230 V/50 Hz
Built-in fuse (slow-blow)	2 A
Max. electrical power consumption	249 W
Electrical power consumption, 30%	159 W
Level of protection	IP X4 D
Test symbol/registration no.	CE-0085BS0402

Index

Index

A

Air index setting	21
Air separator	28
Air separator, filter	28
Air/flue pipe	14
Air/flue pipe, installed	5
Article number	8
Automatic air vent	18

B

Burner anti-cycling time	24
--------------------------------	----

C

Calling up diagnostics codes	23
Carrying out inspection work	25
Carrying out maintenance work	25
CE label	8
Check programmes	16
Checking the burner	27
Checking the CO ₂ content	21
Checking the pre-charge pressure of the expansion vessel	29
Circulation pump	16
Cleaning the condensate duct and the condensate trap	27
Compact thermal module	6, 26
Competent person	4
Completing inspection work	29
Completing maintenance work	29
Completing repair work	30
Completing, repair work	30
Condensate drain pipework	13
Condensate duct	27
Connecting the controller	15
Connection dimensions	9
Corrosion	6
Corrugated gas pipe	6

D

Decommissioning	30
Decommissioning the product	30
Descaling the heat exchanger	27
Descaling, heat exchanger	27
Diagnostics level	23
Disposal, packaging	30
Disposing of the packaging	30
Documents	7
Draining the product	28

E

Electricity	5
Expansion relief valve	13

F

Fault codes	29, 35
Fault memory	29
Filling pressure	18
Filling the condensate siphon	19
Filling the condensate trap	19
Filling the heating installation	18
Filling, heating installation	18
Filter, air separator	28
Flow temperature, maximum	24
Flue gas route	5
From the delivery point to the installation site	8
Front casing, closed	5

Frost	6
-------------	---

G

Gas connection	12
Gas ratio setting	19

H

Handing the product over to the operator	25
Handling	8
Heat exchanger	26
Heating flow	13
Heating partial load	23
Heating return	13
Hot water temperature, risk of scalding	5

I

Identification plate	7
If you smell gas	4
Inspection and maintenance intervals	25
Installation clearances	9
Installation site	5-6
Installer level	23
Installing the compact thermal module	28
Installing the front casing	10
Intended use	4

L

Leak detection spray	6
----------------------------	---

M

Maintenance interval	24
Minimum clearances	9

P

Performing diagnostics	29
Power supply	15
Preparing the repair work	29
Product dimensions	9
Pump operating mode	23
Pump overrun	23
Purging the heating installation	18
Purging, heating installation	18

Q

Qualification	4
---------------------	---

R

Reading off the filling pressure	18
Regulations	6
Removing the condensate trap	27
Replacing the burner	30
Replacing the display	30
Replacing the PCB	30
Replacing, display	30
Replacing, PCB	30
Resetting parameters	29
Resetting, all parameters	29

S

Safety device	5
Schematic drawing	5
Second diagnostics level	23
Serial number	8
Service partner	29
Setting the CO ₂ content	21
Spare parts	26
Supply of combustion air	5
Switching on the product	16

T

Tool	6
Transport	6

Treating the heating water.....	17
U	
Unloading the box	8
V	
Voltage	5
W	
Wall-mounting the product	10

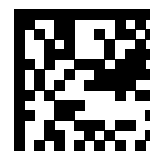

0020214491_01

0020214491_01 ■ 04.01.2017

Supplier

Vaillant Ltd.

Nottingham Road ■ Belper ■ Derbyshire ■ DE56 1JT

Telephone 0330 100 3461

info@vaillant.co.uk ■ www.vaillant.co.uk

© These instructions, or parts thereof, are protected by copyright and may be reproduced or distributed only with the manufacturer's written consent.

We reserve the right to make technical changes.