

Installation and maintenance instructions



ecoTEC plus

VU GB .../5-5

GB, IE

Publisher/manufacturer

Vaillant GmbH

Berghauser Str. 40 ■ D-42859 Remscheid
Tel. +492191 18 0 ■ Fax +492191 18 2810
info@vaillant.de ■ www.vaillant.de



Contents

Contents

1	Safety	4	7.13	Filling the condensate trap	21
1.1	Action-related warnings	4	7.14	Checking and adjusting the gas setting	22
1.2	Intended use	4	7.15	Checking leak-tightness	24
1.3	General safety information	4	7.16	Thoroughly flushing the heating system ("hot")	25
1.4	Regulations (directives, laws, standards)	6	8	Adapting the unit to the heating installation	25
2	Notes on the documentation	7	8.1	Calling up diagnostics codes	25
2.1	Observing other applicable documents	7	8.2	Setting the partial heat load	25
2.2	Storing documents	7	8.3	Setting the pump overrun	25
2.3	Validity of the instructions	7	8.4	Setting the maximum flow temperature	25
2.4	Benchmark	7	8.5	Setting the return temperature control system	26
3	Product description	7	8.6	Burner anti-cycling time	26
3.1	Design of the product	7	8.7	Setting the maintenance interval	26
3.2	Information on the data plate	8	8.8	Pump output (high-efficiency pump)	26
3.3	CE marking	8	8.9	Handing the product over to the end user	28
4	Set-up	8	9	Inspection and maintenance	28
4.1	Unpacking the product	8	9.1	Observing inspection and maintenance intervals	28
4.2	Checking the scope of delivery	8	9.2	Procuring spare parts	29
4.3	Product dimensions and connection dimensions	9	9.3	Using the function menu	29
4.4	Minimum clearances and installation clearances	9	9.4	Carrying out electronics self-tests	29
4.5	Using the mounting template	9	9.5	Removing the gas-air mixture unit	29
4.6	Wall-mounting the product	9	9.6	Cleaning the heat exchanger	31
4.7	Removing/installing the front casing	10	9.7	Checking the burner	31
4.8	Removing/installing the upper casing	10	9.8	Replacing the ignition and ionisation electrodes	31
4.9	Removing/installing the side section (as required)	11	9.9	Cleaning the condensate trap	32
5	Installation	11	9.10	Installing the gas-air mixture unit	32
5.1	Gas installation	11	9.11	Draining the product	33
5.2	Hydraulics installation	12	9.12	Completing inspection and maintenance work	33
5.3	Flue installation	15	10	Troubleshooting	33
5.4	Electrical installation	15	10.1	Contacting your service partner	33
6	Operation	18	10.2	Calling up service messages	33
6.1	Operating concept of the product	18	10.3	Reading off the fault codes	33
6.2	Live Monitor (status codes)	18	10.4	Querying the fault memory	33
6.3	Test programmes	18	10.5	Resetting the fault memory	34
7	Start-up	18	10.6	Performing diagnostics	34
7.1	Auxiliary service equipment	18	10.7	Using check programmes	34
7.2	Carrying out the initial start-up	18	10.8	Resetting parameters to factory settings	34
7.3	Checking and treating the heating water/filling and supplementary water	18	10.9	Preparing the repair work	34
7.4	Switching on the product	19	10.10	Replacing defective components	34
7.5	Running the installation assistants	19	10.11	Completing repair work	36
7.6	Restarting the installation assistants	20	11	Decommissioning	36
7.7	Calling up unit configuration and diagnostics menu	20	11.1	Decommissioning the product	36
7.8	Using check programmes	20	12	Recycling and disposal	36
7.9	Reading off the filling pressure	20	13	Customer service	36
7.10	Preventing low water pressure	20	Appendix	37	
7.11	Flushing the heating system for the first time ("cold")	21	A	Installer level menu structure – Overview	37
7.12	Filling and purging the heating system	21	B	Overview of diagnostics codes	39
			C	Inspection and maintenance work – Overview	41
			D	Status codes – Overview	42
			E	Overview of fault codes	43

F	Wiring diagram.....	45
G	Initial start-up checklist.....	46
G.1	Initial start-up checklist	46
H	Commissioning Checklist.....	49
I	Position of the opening in the air/flue pipe.....	52
I.1	Notes	52
I.2	Positioning of the opening of a fan-supported flue system.....	52
I.3	Horizontal terminal positioning	53
J	Treating the heating water	54
K	Technical data.....	55
Index	57



1 Safety

1 Safety

1.1 Action-related warnings

Classification of action-related warnings

The action-related warnings are classified in accordance with the severity of the possible danger using the following warning signs and signal words:

Warning symbols and signal words



Danger!

Imminent danger to life or risk of severe personal injury



Danger!

Risk of death from electric shock



Warning.

Risk of minor personal injury



Caution.

Risk of material or environmental damage

1.2 Intended use

There is a risk of injury or death to the user or others, or of damage to the product and other property in the event of improper use or use for which it is not intended.

The product is intended as a heat generator for closed heating installations and for domestic hot water generation.

The product must only be installed in installations that have system separation (plate heat exchanger).

Depending on the unit type, the products referred to in these instructions must only be installed and operated in conjunction with the air/flue pipe accessories listed in the other applicable documents.

Intended use includes the following:

- observance of accompanying operating, installation and maintenance instructions for the product and any other system components
- installing and setting up the product in accordance with the product and system approval
- compliance with all inspection and maintenance conditions listed in the instructions.

Intended use also covers installation in accordance with the IP code.

Any other use that is not specified in these instructions, or use beyond that specified in this document, shall be considered improper use. Any direct commercial or industrial use is also deemed to be improper.

Caution.

Improper use of any kind is prohibited.

1.3 General safety information

1.3.1 Risk caused by inadequate qualifications

The following work must only be carried out by competent persons who are sufficiently qualified to do so:

- Set-up
- Dismantling
- Installation
- Start-up
- Inspection and maintenance
- Repair
- Decommissioning
- ▶ Proceed in accordance with current technology.

1.3.2 Risk of injury due to the heavy weight of the product

The product weighs over 50 kg.

- ▶ Make sure that the product is carried by at least two people.
- ▶ Use suitable transport and lifting equipment, in accordance with your risk assessment.
- ▶ Use suitable personal protective equipment: Gloves, safety footwear, protective goggles, protective helmet.

1.3.3 Risk of death due to lack of safety devices

The basic diagrams included in this document do not show all safety devices required for correct installation.

- ▶ Install the necessary safety devices in the installation.
- ▶ Observe the applicable national and international laws, standards and directives.





1.3.4 Risk of death due to cabinet-type casing

Cabinet-type casing can give rise to dangerous situations when used on a product which is operated with an open flue.

- ▶ Ensure that the product is supplied with sufficient combustion air.

1.3.5 Risk of death from escaping gas

What to do if you smell gas in the building:

- ▶ Avoid rooms that smell of gas.
- ▶ If possible, open doors and windows fully and ensure adequate ventilation.
- ▶ Do not use naked flames (e.g. lighters, matches).
- ▶ Do not smoke.
- ▶ Do not use any electrical switches, mains plugs, doorbells, telephones or other communication systems in the building.
- ▶ If it is safe to do so, close the emergency control valve or the main isolator.
- ▶ If possible, close the gas stopcock on the product.
- ▶ Warn other occupants in the building by yelling or banging on doors or walls.
- ▶ Leave the building immediately and ensure that others do not enter the building.
- ▶ Notify the gas supply company or the National Grid +44 (0) 800 111999 by telephone once you are outside of the building.

1.3.6 Risk of damage to the flexible gas pipe

The corrugated gas pipe may become damaged if weight is placed on it.

- ▶ Do not suspend the compact thermal module on the flexible gas pipe, for example during maintenance work.

1.3.7 Risk of death from leaks if the product is installed below ground level

Liquid gas accumulates at floor level. If the product is installed below ground level, liquid gas may accumulate at floor level if there are any leaks. In this case, there is a risk of explosion.

- ▶ Make sure that liquid gas cannot escape from the product or the gas pipe under any circumstances.

1.3.8 Risk of death due to blocked or leaking flue gas routes

Installation errors, damage, tampering, impermissible installation sites or similar can cause flue gas to escape and result in a risk of poisoning.

What to do if you smell flue gas in the property:

- ▶ Open all accessible doors and windows fully to provide ventilation.
- ▶ Switch off the product.
- ▶ Check the flue gas routes in the product and the flue gas diversions.

1.3.9 Risk of death from escaping flue gas

If you operate the product with an empty condensate trap / siphon, then flue gas may escape into the room air.

- ▶ In order to operate the product, ensure that the condensate trap / siphon is always full.

Condition: Permitted B23 or B23P unit types with condensate siphon (third-party accessory)

- Water seal level: ≥ 200 mm

1.3.10 Risk of death due to explosive and flammable materials

- ▶ Do not use the product in storage rooms that contain explosive or flammable substances (such as petrol, paper or paint).

1.3.11 Risk of poisoning caused by insufficient combustion air supply

Condition: Open-flued operation

- ▶ Ensure that the air supply to the product's installation room is permanently unobstructed and sufficient in accordance with the relevant ventilation requirements.

1.3.12 Risk of corrosion damage due to unsuitable combustion and room air

Sprays, solvents, chlorinated cleaning agents, paint, adhesives, ammonia compounds, dust or similar substances may lead





1 Safety

to corrosion on the product and in the flue system.

- ▶ Ensure that the supply of combustion air is always free of fluorine, chlorine, sulphur, dust, etc.
- ▶ Ensure that no chemical substances are stored at the installation site.
- ▶ If you are installing the product in hairdressing salons, painter's or joiner's workshops, cleaning businesses or similar locations, choose a separate installation room in which the room air is technically free of chemical substances.

1.3.13 Risk of poisoning and burns caused by escaping hot flue gases

- ▶ Only operate the product if the air/flue pipe has been completely installed.
- ▶ With the exception of short periods for testing purposes, only operate the product when the front casing is installed and closed.

1.3.14 Risk of death from electric shock

There is a risk of death from electric shock if you touch live components.

Before commencing work on the product:

- ▶ Disconnect the product from the power supply by switching off all power supplies at all poles (electrical partition with a contact gap of at least 3 mm, e.g. fuse or circuit breaker).
- ▶ Secure against being switched back on again.
- ▶ Check that there is no voltage.

1.3.15 Risk of material damage caused by frost

- ▶ Do not install the product in rooms prone to frost.

1.3.16 Risk of material damage caused by using an unsuitable tool

- ▶ Use the correct tool.

1.3.17 Risk of being burned or scalded by hot components

- ▶ Only carry out work on these components once they have cooled down.

1.3.18 Risk of scalding from hot water

There is a risk of scalding at the domestic hot water draw-off points if the domestic hot water temperatures are greater than 60 °C. Young children and elderly persons are particularly at risk, even at lower temperatures.

- ▶ Select a moderate set target temperature.

1.4 Regulations (directives, laws, standards)

- ▶ Observe the national regulations, standards, directives, ordinances and laws.



2 Notes on the documentation

2.1 Observing other applicable documents

- ▶ Always observe all the operating and installation instructions included with the system components.

2.2 Storing documents

- ▶ Pass these instructions and all other applicable documents on to the end user.

2.3 Validity of the instructions

These instructions apply only to:

Product article number

	Article number	Gas Council Number
806 (VU GB 806/5-5)	0010010767	41-044-68
1006 (VU GB 1006/5-5)	0010010780	41-044-69
1206 (VU GB 1206/5-5)	0010010791	41-044-70

2.4 Benchmark

Vaillant is a licensed member of the Benchmark Scheme.

Benchmark places responsibilities on both manufacturers and installers. The purpose is to ensure that customers are provided with the correct equipment for their needs, that it is installed, commissioned and serviced in accordance with the manufacturer's instructions by a competent person approved at the time by the Health and Safety Executive and that it meets the requirements of the appropriate Building Regulations. The Benchmark Checklist can be used to demonstrate compliance with Building Regulations and should be provided to the customer for future reference.

Installers are required to carry out installation, commissioning and servicing work in accordance with the Benchmark Code of Practice which is available from the Heating and Hotwater Industry Council who manage and promote the Scheme.

Benchmark is managed and promoted by the Heating and Hotwater Industry Council.



For more information visit www.centralheating.co.uk

3 Product description

3.1 Design of the product

3.1.1 Functional elements (806/5-5)

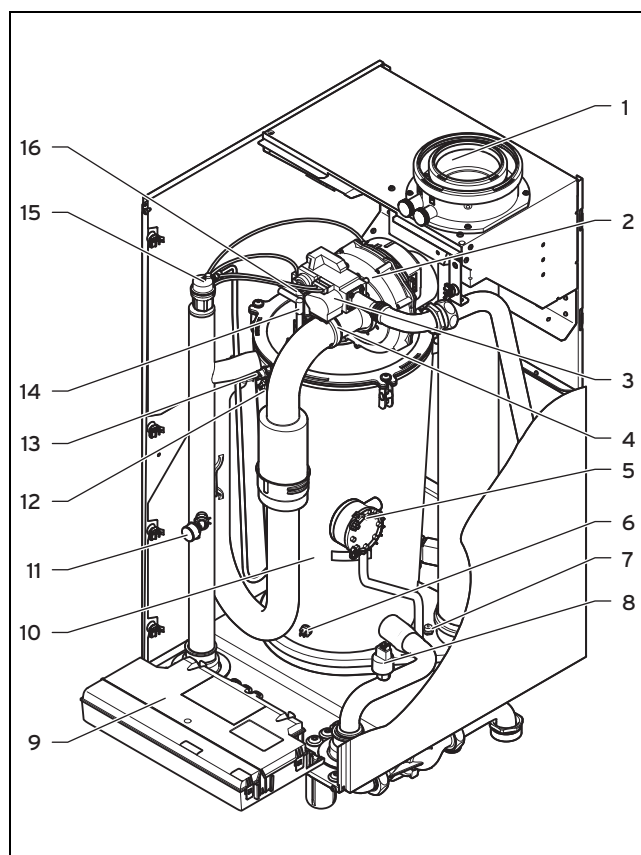

- | | | | |
|---|----------------------------------|----|--------------------------------------|
| 1 | Connection for the air/flue pipe | 9 | Electronics box |
| 2 | Fan | 10 | Integral condensation heat exchanger |
| 3 | Gas valve assembly | 11 | Manometer |
| 4 | Connection for air intake pipe | 12 | Flow temperature sensor |
| 5 | Flue pressure switch | 13 | Safety cut-out |
| 6 | Return temperature sensor | 14 | Ignition electrode |
| 7 | Safety cut-out (flue gas) | 15 | Automatic air vent |
| 8 | Water pressure sensor | 16 | Monitoring electrode |

4 Set-up

3.1.2 Functional element (1006/5-5 and 1206/5-5)

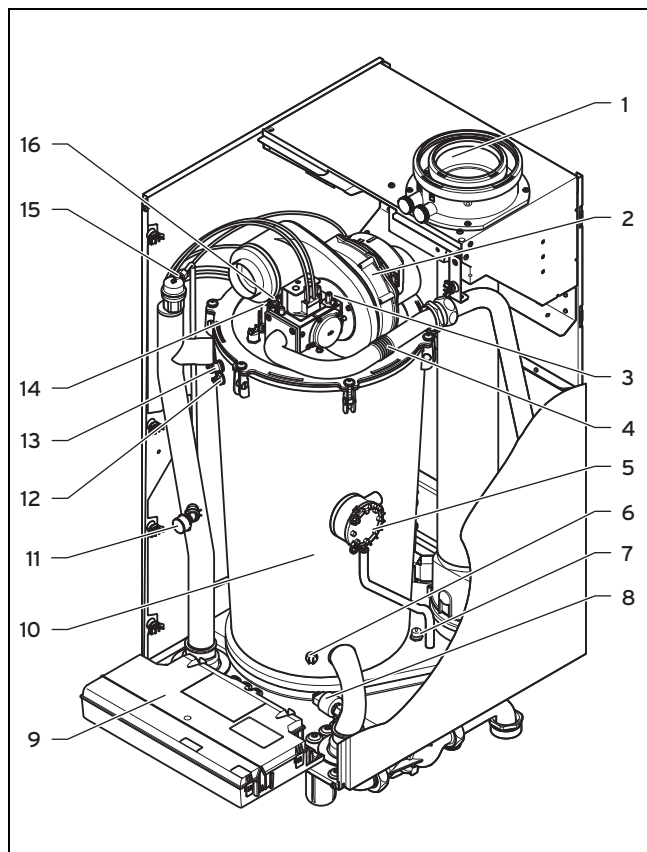

- | | | | |
|---|----------------------------------|----|--------------------------------------|
| 1 | Connection for the air/flue pipe | 9 | Electronics box |
| 2 | Fan | 10 | Integral condensation heat exchanger |
| 3 | Gas pipe | 11 | Manometer |
| 4 | Supply air connector | 12 | Flow temperature sensor |
| 5 | Flue pressure switch | 13 | Safety cut-out |
| 6 | Return temperature sensor | 14 | Ignition electrode |
| 7 | Safety cut-out (flue gas) | 15 | Automatic air vent |
| 8 | Water pressure sensor | 16 | Monitoring electrode |

3.2 Information on the data plate

The data plate is mounted on the underside of the product at the factory.

Information on the identification plate	Meaning
Serial number	for identification; 7th to 16th digits = product article number
VU...	Vaillant gas-fired wall-hung boiler for heating
ecoTEC plus	Product designation
H, G20 – 20 mbar (2.0 kPa)	Gas group and gas connection pressure as set at the factory
Cat. (e.g. II _{2H3P})	Unit category
Types (e.g. C ₃₃)	Gas-fired boiler types
PMS (e.g. 6 bar (0.6 MPa))	Permissible total overpressure
T _{max.} (e.g. 85 °C)	Max. flow temperature
230 V 50 Hz	Electric connection
(e.g. 260) W	Max. electrical power consumption

Information on the identification plate	Meaning
IP (e.g. X4D)	Level of protection
	Heating mode
P	Nominal heat output range
Q	Heat input range



Note

Make absolutely sure that the product is compatible with the gas group at the installation site.

3.3 CE marking



The CE marking shows that the products comply with the basic requirements of the applicable directives as stated on the data plate.

The declaration of conformity can be viewed at the manufacturer's site.

4 Set-up

For fault-free operation and a long service life for the product, you must only install the product in installations with system separation (plate heat exchanger).

4.1 Unpacking the product

1. Remove the product from its box.
2. Remove the protective film from all parts of the product.

4.2 Checking the scope of delivery

- ▶ Check that the scope of delivery is complete and intact.

4.2.1 Scope of delivery

Number	Designation
1	Unit mounting bracket
1	Heat generator
1	Condensate trap
1	Condensate discharge hose
1	Mounting template
1	Enclosed documentation
1	Enclosed unit fastening
1	Bag with small parts
1	Gas connector
1	Service valve (1 1/2 inches), red handle
1	Service valve (1 1/2 inches), blue handle
1	Bag with seals for service valves
1	Expansion relief valve, 6 bar
1	R 1 straight-through gas valve

4.3 Product dimensions and connection dimensions

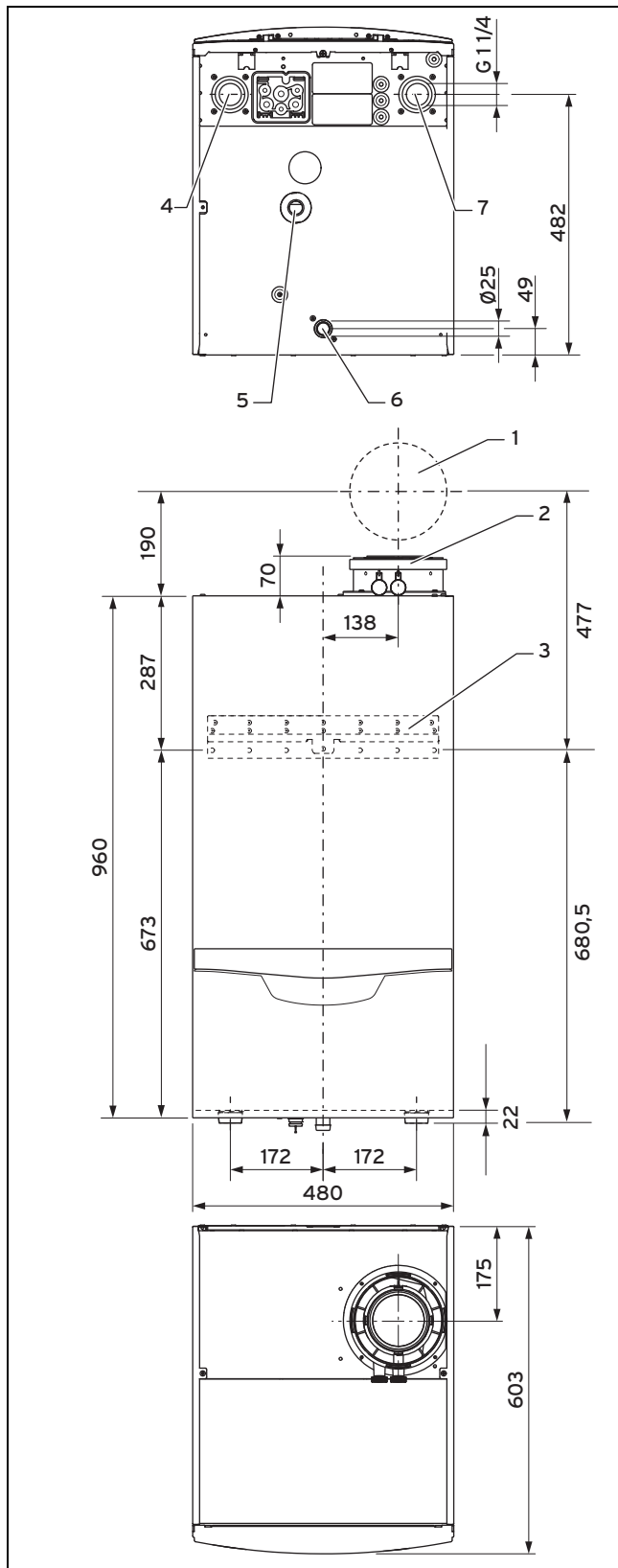

- | | | | |
|---|-------------------------|---|----------------------------|
| 1 | Wall duct for flue pipe | 5 | Condensate trap connection |
| 2 | Flue pipe connection | 6 | Gas connection |
| 3 | Hanging bracket | 7 | Heating return |
| 4 | Heating flow | | |

4.4 Minimum clearances and installation clearances

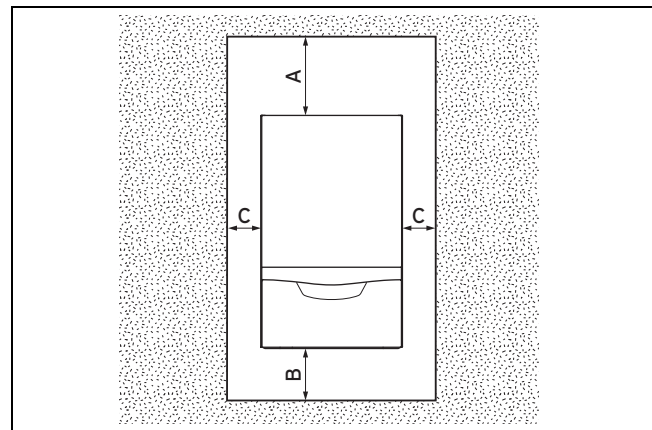

- | | | | |
|---|--|---|---|
| A | 350 mm (110/160 mm diameter flue pipe)
At least 450 mm for cascade design | C | Optional approx. 200 mm |
| B | 400 mm | D | Clearance of 600 mm in front of the product for easy access during maintenance work |

► When using the accessories, observe the minimum clearances/installation clearances.



Note

A lateral clearance is not required, however you can also remove the side sections if there is sufficient space at the side (approx. 200 mm) in order to facilitate maintenance or repair work.

► Where units are installed in cascade, observe the gradient of the flue pipe (approx. 50 mm/m).

It is not necessary to maintain a clearance between the product and components made of combustible materials that go beyond the minimum clearances.

4.5 Using the mounting template

1. Position the mounting template vertically over the installation site.
2. Secure the template to the wall.
3. Mark on the wall all the points required for your installation.
4. Remove the mounting template from the wall.
5. Drill all the holes required.
6. Make any breakthroughs necessary.

4.6 Wall-mounting the product

Condition: The load-bearing capacity of the wall is sufficient, The fixing material may be used for the wall

► Wall-mount the product as described.

Condition: The load-bearing capacity of the wall is not sufficient

- Ensure that wall-mounting apparatus on-site has a sufficient load-bearing capacity. Use individual stands or primary walling, for example.
- Do not wall-mount the product if you cannot provide wall-mounting apparatus with a sufficient load-bearing capacity.

4 Set-up

Condition: The fixing material may not be used for the wall

- ▶ Wall-mount the product as described using the permitted fixing material provided on-site.

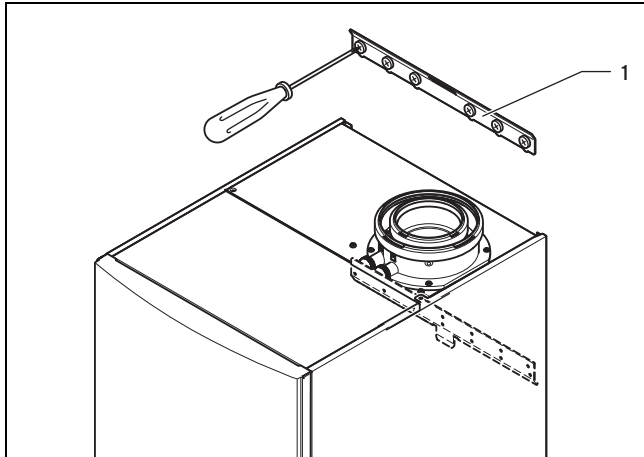

1. Install the hanging bracket (1) on the wall.
2. Suspend the product on the hanging bracket from above using the suspension bracket.

4.7 Removing/installing the front casing

4.7.1 Removing the front casing

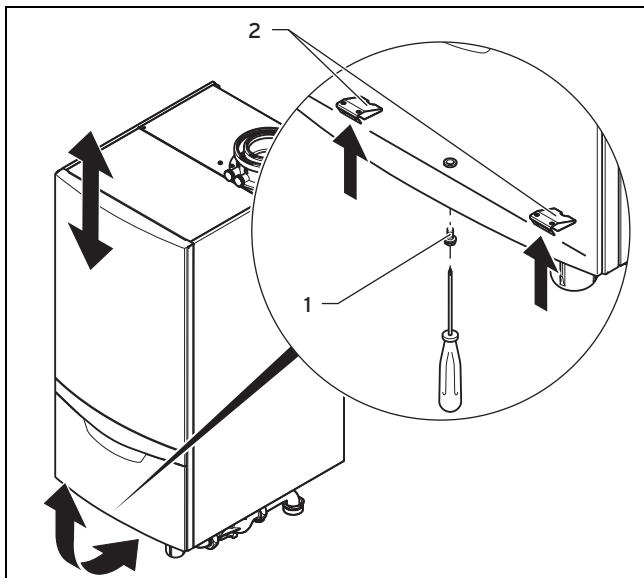

1. Undo the bolt (1).
2. Push in both retaining clips (2) so that the front casing is released.
3. Pull the front casing forwards at the bottom edge.
4. Lift the front casing upwards from the bracket.

4.7.2 Installing the front casing

1. Place the front casing on the upper brackets.
2. Push the front casing onto the product until both retaining clips (2) snap into place at the front casing.
3. Secure the front casing by tightening the screw (1).

4.8 Removing/installing the upper casing

4.8.1 Removing the upper casing

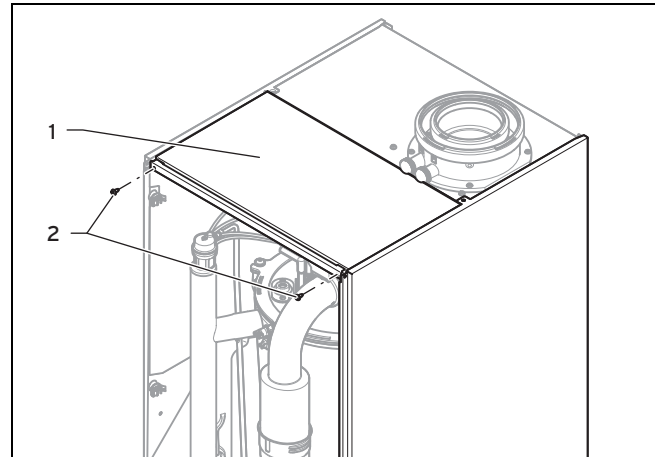

1. Unscrew the screws (2).
2. Pull out the upper casing (1) towards the front.

4.8.2 Installing the upper casing

1. From above, place the upper casing (1) on the product.
2. Use the screws (2) to secure the upper casing (1).

4.9 Removing/installing the side section (as required)

4.9.1 Removing the side section

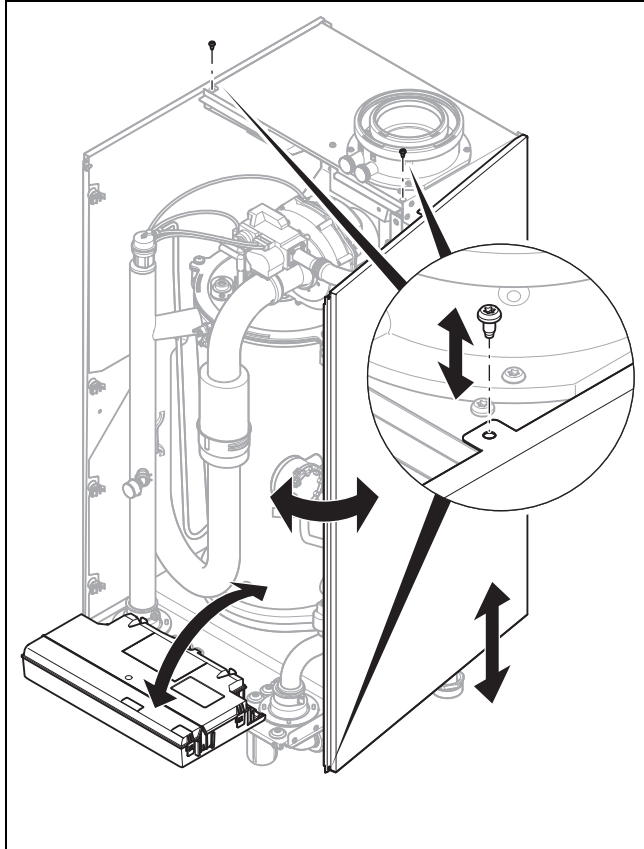

Caution.
Risk of material damage caused by mechanical deformation.

Removing **both** side sections may cause mechanical distortion in the product, which may cause damage to the piping, for example, and potentially result in leaks.

- ▶ Always only remove **one** side section – never both side sections at the same time.

1. Hinge the electronics box forward.
2. Remove the upper casing. (→ Page 10)
3. Hold on to the side section so that it cannot fall, and unscrew the lower front and upper central screws from the side section.
4. Hinge the side section slightly to the side and pull it out towards the front.

4.9.2 Installing the side section

1. Push the side section into the bracket. When doing so, and to prevent leaks, ensure that all straps on the side section engage with the back panel.
2. Slide the side section to the rear.
3. Secure the side section using two screws in the front lower area and in the upper central area.
4. Install the upper casing. (→ Page 10)
5. Hinge up the electronics box.

5 Installation



Danger!
Risk of explosion or scalding caused by incorrect installation.

Mechanical stresses in the connection pipes may lead to leaks.

- ▶ Make sure that the connection pipes are free from mechanical stress when they are installed.



Caution.
Risk of material damage caused by residues in the pipelines.

Welding remnants, sealing residues, dirt or other residues in the pipelines may damage the product.

- ▶ Flush the heating installation thoroughly before installing the product.



Caution.
Risk of material damage caused by changes to the pipes that have already been connected.

- ▶ Only bend connection pipes if they have not yet been connected to the product.

Seals made of rubber-like materials may be subject to plastic deformation, which can lead to pressure losses. We recommend using seals made of a paste-like fibre material.

5.1 Gas installation

5.1.1 Performing the gas installation



Caution.
Risk of material damage caused by incorrect gas installation.

Excessive test pressure may cause damage to the gas valve.

- ▶ When checking the entire gas installation for leak-tightness, the maximum permissible pressure at the gas valve is 7.5 kPa (75 mbar).



Caution.
Risk of material damage caused by the incorrect gas type.

Using the wrong gas type may cause a fault shutdown of the product. Furthermore, ignition and combustion noise may occur in the product.

- ▶ Only use the gas types in accordance with the data plate.

5 Installation

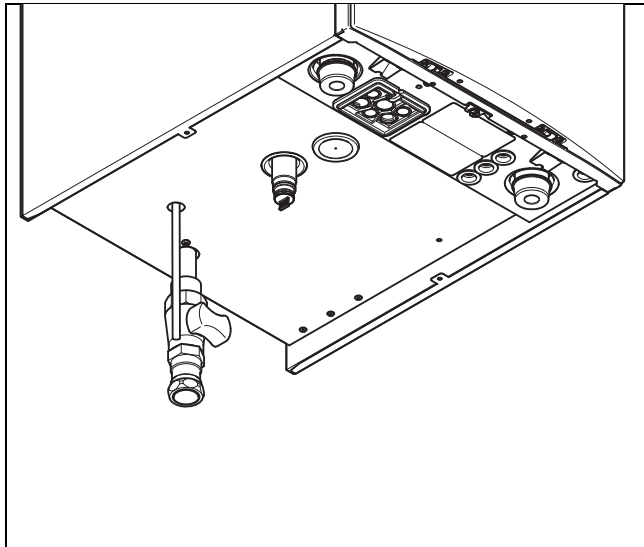

- ▶ Make sure that the existing gas meter is capable of passing the rate of gas supply required.
- ▶ Remove the residues from the gas pipe by blowing through the gas pipe beforehand.
- ▶ Make sure that the existing gas meter is capable of passing the rate of gas supply required.
- ▶ Install an approved gas stopcock on the product using the gas connector.
- ▶ Install the gas pipe on the gas stopcock such that it is free from mechanical stress.
- ▶ Purge the gas pipe before start-up.

5.1.2 Checking the gas line for leak-tightness

- ▶ Check the entire gas line properly for leak-tightness.

5.1.3 Information on liquid gas operation

In the as-supplied condition, the product is preset for operation with the gas group indicated on the data plate.

5.1.4 Purging the liquid gas tank

If the liquid gas tank is not purged properly, this may result in ignition problems.

- ▶ Ensure that the liquid gas tank has been purged properly before installing the product.
- ▶ If required, contact the filler or the liquid gas supplier.

5.1.5 Using the correct gas type

Using the incorrect gas type may cause fault shutdowns in the product. Ignition and combustion noise may occur in the product.

- ▶ Only use the gas type listed on the data plate.

5.2 Hydraulics installation



Caution.

Risk of material damage due to high temperatures.

Plastic pipes in the heating installation may become damaged by overheating if a fault occurs.

- ▶ When using plastic pipes, install a limit thermostat on the heating flow.



Caution.

Risk of material damage due to heat transfer during soldering.

- ▶ Only solder connectors if the connectors are not yet screwed to the service valves.

- ▶ Please note that water above 150 mg/l CaCO₃ is classified as hard and the corresponding treatment is required (→ Page 18).

The product should be connected using a Vaillant pump group (accessories).

- High-efficiency pump

This pump group has a connection option for an expansion vessel (right-hand connection) and an expansion relief valve (left-hand connection). You can find information about available accessories from the Vaillant price list or from the contact address provided on the reverse of this document.

- ▶ When installing the pump group, observe the installation sequence for the insulation and the hydraulic pipes (Pump group installation instructions).
- ▶ Note that the boiler pump must always be fitted in the return line. Otherwise, this may lead to a malfunction in the product.

When connecting several products in cascade operation, you must install a non-return flap from the cascade connection set in the flow line of each individual product.

A non-return flap from a third-party manufacturer must have no more than 30 mbar pressure loss for a volume flow of 4.5 m³/h.

5.2.1 Connecting the heating flow and heating return

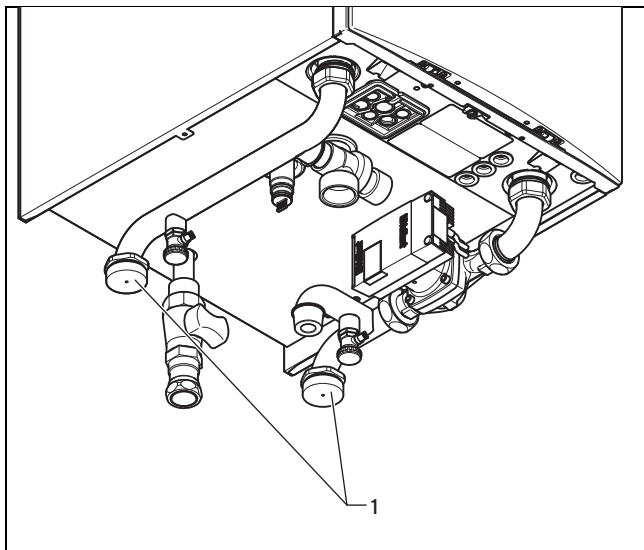

1. In each case, insert a flat seal into the service valve (Vaillant accessories).
2. Screw the service valves onto the flow and return connection **(1)** of the pump group.
3. Screw the service valves to the customer's installation.
 - Diameter of the heating line: 1 1/4"

5.2.2 Installing the expansion vessels

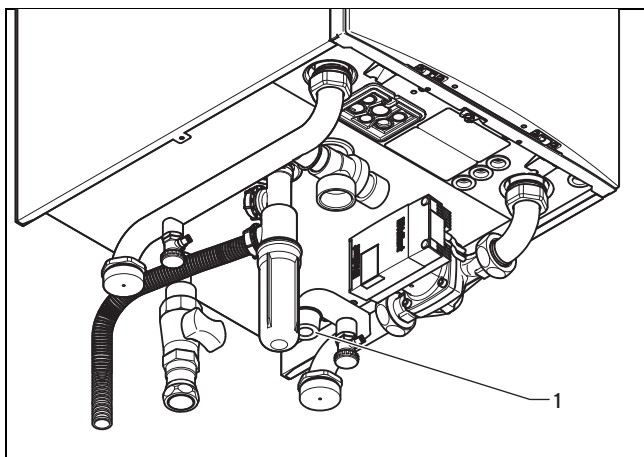

1. Install a sufficiently dimensioned expansion vessel at the connection in the boiler circuit return **(1)** and in the installation circuit.
 - Connection to the pump group: 1/2"
 - Large expansion vessel: ≥ 10 l
2. Check that the volumetric capacity of the expansion vessel in the installation circuit is sufficient for the system volume.

5.2.3 Hydraulic connection

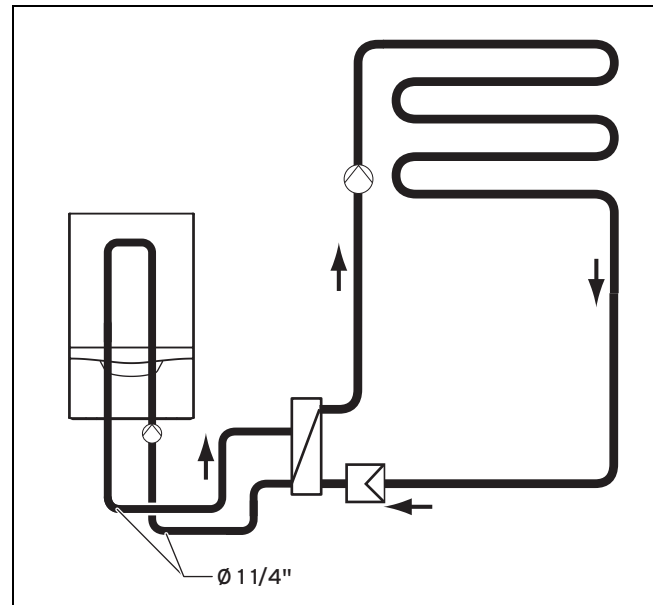

The manufacturer recommends installing the following components in addition to the specified plate heat exchanger for the hydraulic system separation:

- A dirt filter installed on the installation side upstream of the plate heat exchanger
- Heating-side cleaning connections for backwashing the plate heat exchanger during maintenance work

To this end, various plate heat exchangers are available as accessories, depending on the output of a product or whether it is a cascade system. The pressure loss is adjusted to the pump groups that are offered as an accessory. The minimum circulation water volume in the unit circuit is only guaranteed if you use original accessories in the unit circuit, provided that the maximum pressure losses in the piping are not exceeded. The manufacturer therefore urgently recommends that you only install original pump groups.

Select the plate heat exchanger according to output.

Depending on the unit output, different remaining feed heads (→ Page 26) are available at the boiler circuit's flow pipe.

Observe the following pressure losses (nominal volume flow at $\Delta T=20\text{ K}$):

Power	Pressure loss
< 120 kW	86 mbar (0.086 bar)
In conjunction with the hydraulic cascade	
< 240 kW	96 mbar (0.096 bar)
< 360 kW	76 mbar (0.076 bar)
< 480 kW	82 mbar (0.082 bar)
< 600 kW	87 mbar (0.087 bar)
< 720 kW	92 mbar (0.092 bar)

5 Installation

5.2.4 Connecting the condensate trap

Condensate forms in the product during combustion. The condensate drain pipework routes the condensate to the waste water connection.

The product is equipped with a condensate trap. The filling height is 145 mm. The condensate trap collects any condensate that forms and feeds it into the condensate discharge pipe.

- ▶ Place the condensate trap on the underside of the product on the condensate drain pipe and secure it using the retaining clips.
- ▶ Leave installation space of at least 180 mm below the condensate trap so that you can clean the condensate trap in the event of maintenance work.
- ▶ Before you start up the product, fill the condensate trap with water (→ Page 21).
- ▶ Check the connection point for leak-tightness (→ Page 24).

5.2.5 Connecting the condensate discharge pipe

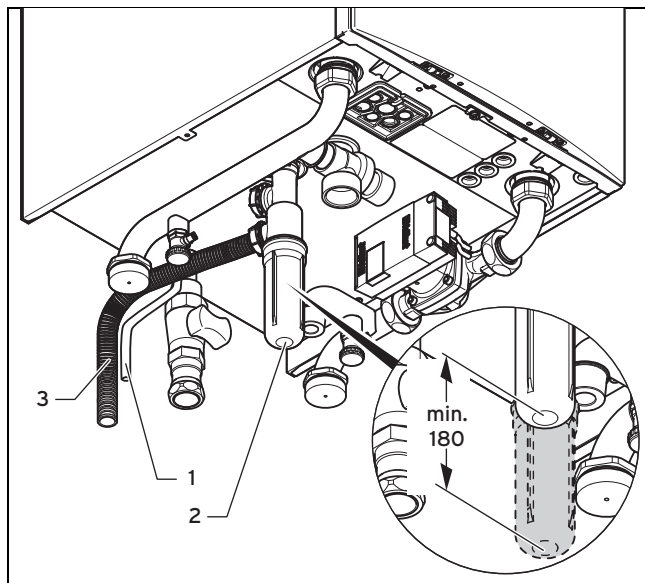

- ▶ When making the condensate pipe connections ensure that there is adequate branch ventilation and that there can be no backflow of water into the boiler via the condensate pipe work.
- ▶ Check if a neutralising unit is required in accordance with national regulations.
- ▶ Observe the local regulations on neutralising the condensate.



Note

You can obtain neutralisation with or without a condensate pump as an accessory.

- ▶ If required, guide the drain hose (1) from the automatic air vent into the tundish.



Note

The condensate drain pipework must have a continuous fall (45 mm per metre) and should whenever possible terminate at a suitable drain point within the heated envelope of the building that will remain frost free under long periods of low external temperatures.

5.2.6 Connecting the expansion relief valve



Note

The product is delivered with a 6 bar expansion relief valve, which must be installed on the product and must be guided to a secure, but visible, point. The drain pipe on the expansion relief valve must have a minimum diameter of 28 mm and must only be used for this purpose.

1. Ensure that all components that are installed in the heating installation are suitable for a max. operating pressure of 6 bar.

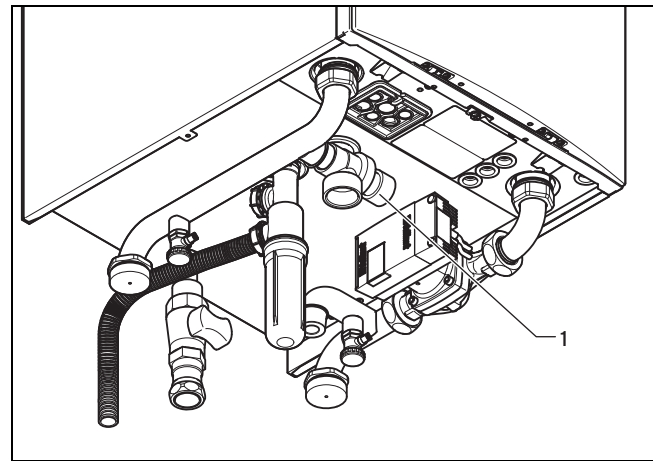

Danger!

Risk of scalding!

Heating water that leaks from the exit point of the expansion relief valve may cause severe scalds.

- ▶ Install the expansion relief valve drain to a professional standard.

2. Connect the expansion relief valve (1).



Note

When selecting the expansion relief valve, note the max. operating pressure of the heating installation.

5.3 Flue installation

5.3.1 Air/flue pipes that can be connected

- ▶ When installing the air/flue pipe, observe the provisions of the applicable national regulations.



Note

All products feature an 110/160 mm diameter air/flue connection as standard.

You can find out which air/flue pipes may be used by consulting the enclosed set-up instructions for the air/flue system.

5.3.2 Installing the air/flue pipe



Caution.

Risk of poisoning due to escaping flue gas.

Mineral-oil-based greases can damage the seals.

- ▶ Instead of grease, use only water or commercially available soft soap to aid installation.



Danger!

Risk of personal injury and material damage due to unapproved air/flue pipes.

Vaillant boilers are certified only with Vaillant original air/flue pipes. The use of other accessories may cause personal injury and material damage, as well as operating faults. For installation type B23P, third-party accessories are also permitted (see the technical data in the appendix).

- ▶ Only use Vaillant original air/flue pipes.
- ▶ If third-party accessories are permitted for B23P, ensure that the flue pipe connections are properly routed, sealed and secured against slipping out.

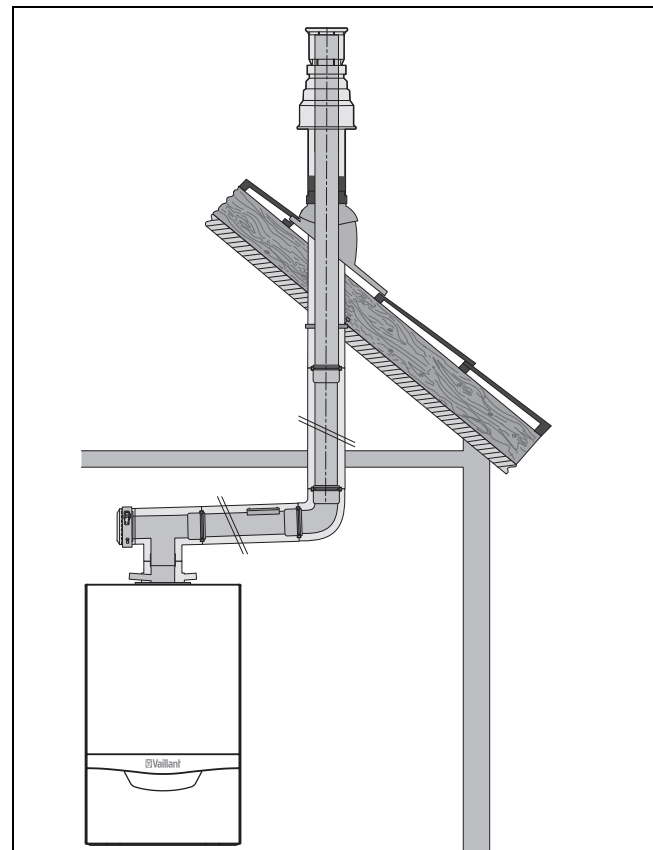

1. Install the flue pipe using the installation manual.
2. When installing the air/flue pipe, observe the provisions of the applicable national regulations.
3. Route the flue pipe with a downward gradient so that the condensate that accumulates can easily flow into the condensate trap provided for it.

5.4 Electrical installation

Only qualified electricians may carry out the electrical installation.



Danger!

Risk of death from electric shock!

Power supply terminals L and N remain live even if the on/off button is switched off:

- ▶ Disconnect the product from the power supply by switching off all power supplies at all poles (electrical partition with a contact gap of at least 3 mm, e.g. fuse or circuit breaker).
- ▶ Secure against being switched back on again.
- ▶ Wait for at least 3 minutes until the capacitors have discharged.
- ▶ Check that there is no voltage.

5 Installation

5.4.1 Opening/closing the electronics box

5.4.1.1 Opening the electronics box

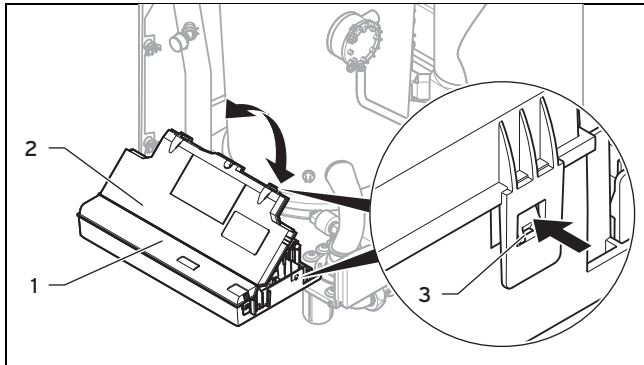

1. Remove the front casing. (→ Page 10)
2. Hinge the electronics box (1) forward.
3. Undo the clips (3) from the brackets.
4. Hinge up the cover (2).

5.4.1.2 Closing the electronics box

1. Close the cover (2) by pushing downwards on the electronics box (1).
2. Ensure that all the clips (3) audibly click into the brackets.
3. Hinge the electronics box upwards.

5.4.2 Establishing the power supply



Caution.

Risk of material damage due to high connected voltage.

At mains voltages greater than 253 V, electronic components may be damaged.

- ▶ Ensure that the nominal voltage of the mains is 230 V (+10%/-15%) ~ 50 Hz.

1. Observe all valid regulations.
2. Open the electronics box. (→ Page 16)
3. Provide one common electricity supply for the boiler and for the corresponding controller:
 - Power supply: Single-phase, 230 V, 50 Hz
 - Fuse protection: ≤ 3 A
4. Connect the product using a fixed connection and a partition with a contact opening of at least 3 mm (e.g. fuses or power switches).
5. Use a flexible line for the mains feed line, which is routed through the cable duct into the product.
6. Carry out the wiring. (→ Page 16)
7. Observe the connection diagram (→ Page 45).
8. Screw the supplied ProE plug to a suitable, flexible three-core mains connection cable which complies with the relevant standards.
9. Close the electronics box. (→ Page 16)
10. Make sure that access to the mains connection is always available and is not covered or blocked.

5.4.3 Carrying out the wiring



Caution.

Risk of material damage caused by incorrect installation.

Mains voltage at the incorrect plug terminals on the ProE system may destroy the electronics.

- ▶ Do not connect any mains voltage to the eBUS terminals (+/-).
- ▶ Only connect the power supply cable to the terminals marked for the purpose.

1. Route the supply lines of the components to be connected through the cable duct provided on the underside of the product.
2. Use the strain reliefs provided.
3. Shorten the supply lines as necessary.
4. To prevent short circuits if a strand accidentally comes loose, only strip the outer sheathing of flexible lines to a maximum of 30 mm.
5. Ensure the inner conductor insulation is not damaged when stripping the outer sheathing.
6. Only strip inner conductors just enough to establish good, sound connections.
7. To avoid short circuits resulting from loose individual wires, fit conductor end sleeves on the stripped ends of the conductors.
8. Screw the respective ProE plug to the supply line.
9. Check whether all conductors are sitting mechanically securely in the terminals of the ProE plug. Remedy this if necessary.
10. Plug the ProE plug into the associated PCB slot.
11. Secure the cable in the electronics box using the strain reliefs.

5.4.4 Connecting the pump group

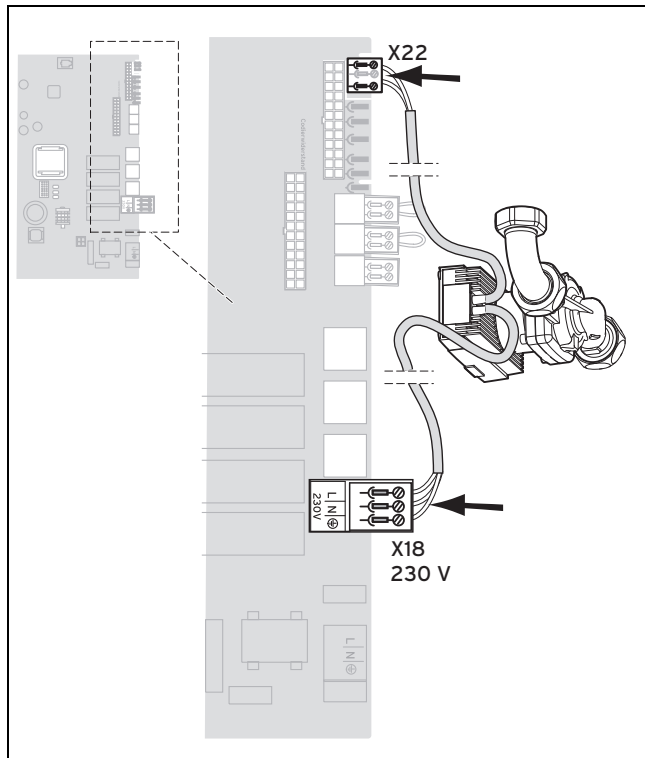

1. Open the electronics box. (→ Page 16)
2. Carry out the wiring. (→ Page 16)
3. Use the strain reliefs provided.
4. Plug the ProE plug for the power supply cable into slot X18.
5. Plug the ProE plug for the control cable into slot X22.
6. Close the electronics box. (→ Page 16)

5.4.5 Installing the control

- Install the control if necessary.

5.4.6 Connecting controls to the electronics

1. Open the electronics box. (→ Page 16)
2. Carry out the wiring. (→ Page 16)
3. If you connect a weather-compensated control or room thermostat to the product via eBUS, bridge the input 24 V = RT (X100 or X106) if no bridge exists.
4. If you use a low-voltage control (24 V), connect this instead of the bridge 24 V = RT (X100 or X106).
5. When connecting a limit thermostat (surface-mounted thermostat) for underfloor heating, connect this instead of the bridge (Burner off) at the ProE plug.
6. Close the electronics box. (→ Page 16)



Note

Due to the installed system separation, leave the pump in the factory setting: **Comfort D.018**

5.4.7 Connecting additional components

You can use the multi-functional module to actuate two additional components.

The following components can be actuated:

- Circulation pump
- External pump
- Cylinder charging pump
- Extraction hood
- External solenoid valve
- External fault signal
- Solar pump (not active)
- eBUS remote control (not active)
- Anti-legionella pump (not active)
- Solar valve (not active).

5.4.7.1 Using the VR 40 (2 in 7 multi-functional module)

1. Install the components in accordance with the respective instructions.
2. Select **D.027** (→ Page 25) to actuate relay 1 on the multi-functional module.
3. Select **D.028** (→ Page 25) to actuate relay 2 on the multi-functional module.

5.4.7.2 Using the flue non-return flap

For cascade operation, you must provide a flue non-return flap for each product. Either use only electrical flue non-return flaps or use only mechanical flue non-return flaps for all products in a cascade.

The electrical flue non-return flap is actuated by the **VR 40** multi-functional module. The installation instructions for the **VR 40** describe how the flue non-return flap is activated. The mechanical flue non-return flap has an integrated siphon, which must be filled with water before starting up the unit.

You can omit the flue non-return flap if you can ensure that the flue system is operated completely under negative pressure.

Condition: Operating with natural gas

- For smooth operation with natural gas and a flue non-return flap, use diagnostics code **D.050** (→ Page 25) to increase the offset for the minimum fan speed to the **fixed value** of 1500 rpm.

Condition: Operating with liquefied petroleum gas

- You must never raise the speed under **D.050** (→ Page 25) any higher because a higher speed is already being used when operating with liquid gas.

5.4.8 Actuating the circulation pump according to requirements

1. Connect the wiring in the same way as described in "Connecting controllers to the electronic system (→ Page 17)".
2. Connect the supply line for the external button using terminals 1 ⊕ (0) and 6 (functional drawing) on the X41 edge connector, which is supplied with the controller.
3. Plug the edge connector into the PCB slot X41.

6 Operation

6 Operation

6.1 Operating concept of the product

The operating concept and the read-out and setting options of the end user level are described in the operating instructions.

An overview of the read-out and setting options of the installer level can be found in the section "Overview of the menu structure – Installer level" (→ Page 37).

6.1.1 Calling up the installer level



Caution.

Risk of material damage caused by incorrect handling.

Incorrect settings at installer level may cause damage and operating faults to the heating installation.

- ▶ You must only access the installer level if you are an approved competent person.



Note

The installer level is protected against unauthorised access using a password.

1. Press and ("i") simultaneously.
 - ◀ The following menu appears in the display.
2. Scroll using the or button, until the menu item **Installer level** appears.
3. Press **(OK)** to confirm your selection.
 - ◀ In the display, the text **Enter code** appears along with the value **00**.
4. Use or to set the value **17** (code).
5. Press **(OK)** to confirm your selection.
 - ◀ The installer level appears with a selection of menu items.

6.2 Live Monitor (status codes)

Menu → Live Monitor

Status codes in the display provide information on the product's current operating status.

Status codes – Overview (→ Page 42)

6.3 Test programmes

As well as the installation assistants, you can also call up the test programmes for start-up, maintenance and troubleshooting.

Menu → Installer level Test programmes

There you will find the **Check programmes** (→ Page 20), in addition to the **Function menu**, an **Electronics self-test** and the **Gas family check**.

7 Start-up

7.1 Auxiliary service equipment

The following test and measuring equipment is required for start-up:

- CO₂ analyser
- Digital or U-tube manometer
- Flat-blade screwdriver, small
- 2.5 mm hex key

7.2 Carrying out the initial start-up



Note

The complete heating system must be flushed at least twice: Once with cold water and once with domestic hot water in accordance with the following instructions (→ section "Flushing the heating installation for the first time")

Initial start-up must be carried out by a customer service technician or an authorised competent person using the first-commissioning-checklist and the commissioning checklist. The first-commissioning-checklist and the commissioning checklist (→ Page 49) in the appendix for the installation instructions must be filled out and stored carefully along with the product documentation.

Initial start-up checklist (→ Page 46)

- ▶ Carry out the initial start-up using the checklist and the commissioning checklist in the appendix.
- ▶ Fill out and sign the checklists.

7.3 Checking and treating the heating water/filling and supplementary water



Caution.

Risk of material damage due to poor-quality heating water

- ▶ Ensure that the heating water is of sufficient quality.

- ▶ Before filling or topping up the installation, check the quality of the heating water.

Checking the quality of the heating water

- ▶ Remove a little water from the heating circuit.
- ▶ Check the appearance of the heating water.
- ▶ If you ascertain that it contains sedimentary materials, you must desludge the installation.
- ▶ Use a magnetic rod to check whether it contains magnetite (iron oxide).
- ▶ If you ascertain that it contains magnetite, clean the installation and apply suitable corrosion-protection measures, or fit a magnet filter.
- ▶ Check the pH value of the removed water at 25 °C.
- ▶ If the value is below 8.2 or above 10.0, clean the installation and treat the heating water.
- ▶ Ensure that oxygen cannot get into the heating water.

Checking the filling and supplementary water

- ▶ Before filling the installation, measure the hardness of the filling and supplementary water.

Treating the filling and supplementary water

- ▶ Observe all applicable national regulations and technical standards when treating the filling and supplementary water.

Provided the national regulations and technical standards do not stipulate more stringent requirements, the following applies:

You must treat the heating water in the following cases:

- If the entire filling and supplementary water quantity during the operating life of the system exceeds three times the nominal volume of the heating installation, or
- If the values shown in the curve (Appendix) have been exceeded, or
- If the pH value of the heating water is less than 8.2 or more than 10.0.



Caution.

Risk of material damage if the heating water is treated with unsuitable additives.

Unsuitable additives may cause changes in the components, noises in heating mode and possibly subsequent damage.

- ▶ Do not use any unsuitable frost and corrosion protection agents, biocides or sealants.

No incompatibility with our products has been detected to date with proper use of the following additives.

- ▶ When using additives, follow the manufacturer's instructions without exception.

We accept no liability for the compatibility of any additive or its effectiveness in the rest of the heating system.

Additives for cleaning measures (subsequent flushing required)

- Adey MC3+
- Adey MC5
- Fernox F3
- Sentinel X 300
- Sentinel X 400

Additives intended to remain permanently in the installation

- Adey MC1+
- Fernox F1
- Fernox F2
- Sentinel X 100
- Sentinel X 200

Additives for frost protection intended to remain permanently in the installation

- Adey MC ZERO
- Fernox Antifreeze Alpha 11
- Sentinel X 500

- ▶ If you have used the above-mentioned additives, inform the end user about the measures that are required.
- ▶ Inform the end user about the measures required for frost protection.

7.4 Switching on the product

- ▶ Press the on/off button on the product.
 - ◀ The basic display appears on the display.

7.5 Running the installation assistants

The installation assistant is displayed whenever the product is switched on until it has been successfully completed. It provides direct access to the most important check programmes and configuration settings for starting up the product.

Confirm the launch of the installation assistant. All heating and domestic hot water demands are blocked whilst the installation assistant is active.





Confirm that you want to navigate to the next point by pressing **Next**.

If you do not confirm the launch of the installation assistant, it is closed 10 seconds after you switch on the unit and the basic display then appears.

7.5.1 Language

- ▶ Set the required language.
- ▶ Press (**OK**) twice to confirm the set language and to avoid unintentionally changing it.



If you have unintentionally set a language that you do not understand, proceed as follows to change it:

- ▶ **Simultaneously press and hold**  and .
- ▶ Also press the fault clearance key for a short time.
- ▶ Press and hold  and  until the display shows the language setting option.
- ▶ Select the required language.
- ▶ Confirm this change by pressing (**OK**) twice.



7.5.2 Filling mode

Filling mode (check programme **P.06**) is activated automatically in the installation assistant for as long as the filling mode appears on the display.

7.5.3 Purging

1. Unlike in the check programmes menu, to purge the system, start up the check programme **P.00** by pressing  or .
2. If you need to change the circuit that is being purged, press .

7.5.4 Target feed temperature, hot water temperature, Comfort mode

1. To set the target feed temperature, hot water temperature and Comfort mode, use the  and  buttons.
2. Confirm the setting by pressing (**OK**).

7.5.5 Partial heat load

The partial heat load of the product is set to **Auto** at the factory. This means that the product independently determines the optimum heating output depending on the current heat demand of the installation. The setting can also be changed at a later point using **D.000**.

7 Start-up

7.5.6 Additional relay and multi-functional module

Additional components that are connected to the product can be adjusted here. This setting can be changed using **D.027** and **D.028**.

7.5.7 Competent person telephone number

You can store your telephone number in the unit menu. The end user can view the telephone number. The telephone number can be up to 16 digits long and must not contain any spaces.

7.5.8 Ending the installation assistant

Once the installation assistant has been completed and confirmed, it will not start up automatically next time the unit is switched on.

7.6 Restarting the installation assistants

You can restart the installation assistant at any time by calling it up in the menu.

Menu → **Installer level** → **Start inst. assistant**

7.7 Calling up unit configuration and diagnostics menu

To recheck and reset the most important system parameters, call up the **Unit configuration**.

Menu → **Installer level Unit configuration**





The setting options for more complex installations can be found in the **Diagnostics menu**.

Menu → **Installer level Diagnostics menu**

7.8 Using check programmes

Menu → **Installer level** → **Test programmes** → **Check programmes**

By activating various check programmes, you can trigger special functions on the product.

Display	Meaning
P.00	<p>Purging check programme: The boiler circulation pump is cyclically actuated. The heating circuit is purged via the automatic air vent.</p> <p>1 x : Start heating circuit purging 3 x  ( ): Restart heating circuit purging 1 x  (Cancel): End purge programme</p> <p>Note The purge programme runs for 7.5 min per circuit and then terminates. Purging the heating circuit: Actuating the external pump for 15 cycles: 15 s on, 10 s off. Display: Active heating circuit.</p>
P.01	<p>Maximum load check programme: After successful ignition, the product is operated at maximum heat input.</p>
P.02	<p>Minimum load check programme: After successful ignition, the product is operated at minimum heat input.</p>
P.06	<p>Filling mode check programme: The burner and pump are switched off (to fill or drain the product).</p>

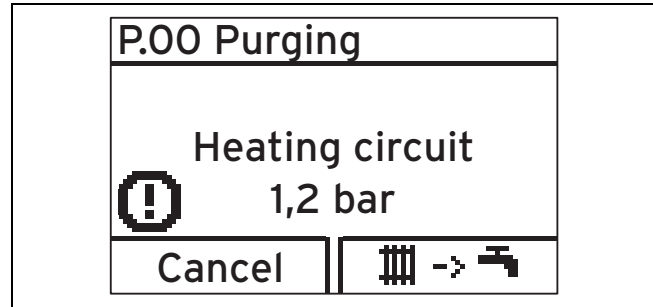

Note

If the product is in error condition, you cannot start any check programmes. You can detect an error condition by the fault symbol shown in the left bottom corner of the display. You must first reset.

To terminate the check programmes, you can press (**Cancel**) at any time.

7.9 Reading off the filling pressure

The product's supply pipe is equipped with an analogue pressure gauge, a symbolic bar graph display and a digital pressure gauge.

- ▶ To read off the digital filling pressure value, press the  button twice.

If the heating installation is full, in order to ensure that it operates smoothly, the indicator on the pressure gauge must point to the upper half of the grey area or to the middle of the bar graph display on the display (marked by the dashed limit values) when the heating installation is cold. This corresponds to a filling pressure of between 0.1 MPa and 0.2 MPa (1.0 bar and 2.0 bar).

If the heating installation extends over several storeys, higher filling pressures may be required to avoid air entering the heating installation.

7.10 Preventing low water pressure

To prevent damage to the boiler that is caused by a filling pressure that is too low, the boiler is fitted with a water pressure sensor. If the filling pressure falls below 0.1 MPa (1.0 bar), the product indicates low pressure by displaying a flashing pressure value. If the filling pressure falls below 0.05 MPa (0.5 bar), the product switches off. The display shows **F.22**.

- ▶ Top up the heating water to start the product up again.

The pressure value flashes in the display until a pressure of 0.11 MPa (1.1 bar) or higher has been reached.

- ▶ If you notice frequent drops in pressure, determine and eliminate the cause.

7.11 Flushing the heating system for the first time ("cold")



Note

Establish suitable connections for correctly filling the boiler circuit and use a suitable filling device. Due to the system separation, separate connections are required for the installation circuit.

1. Check that all thermostatic radiator valves and both service valves on the boiler are open.
2. Select the check programme **P.06**.
 - ◁ The pumps do not run and the product does not enter heating mode.
3. Open the filling water supply.
4. Slowly fill the boiler and the heating installation.
5. Open all available purging valves in the heating system.



Note

The boiler is equipped with an automatic air vent. Other measures need to be taken to allow the heating system to be purged during filling and during commissioning either manually or using an automatic air vent.

6. Connect a hose to the drain valve that is located at the lowest position in the heating system.
7. Connect a hose to the boiler's drain valve.
8. Open these two drain valves so that the water can drain quickly. Start at the next point in the installation and open the purging valves on the radiators so that the contaminated water can completely drain.
9. Close the drain cocks.

7.12 Filling and purging the heating system

Condition: The heating installation and the boiler have been rinsed thoroughly.

- ▶ Select the check programme **P.06**.
 - ◁ The pumps do not run and the product does not enter heating mode.
1. Proceed in accordance with the information provided on treating (→ Page 18) heating water and on the topic of water hardness (→ Page 54).
 2. Open the filling water supply.
 3. Check that both service valves on the boiler are open.
 4. Slowly fill the boiler.
 5. Observe the increasing filling pressure in the boiler.
 6. Fill with water until the required filling pressure is reached.
 7. Close off the filling system but keep ready to top up as air is expelled during the purging process.
 8. To purge the boiler, select check programme **P.00**.
 - ◁ The boiler does not start up, the external pump operates intermittently and purges either the heating circuit or the domestic hot water circuit. The display shows the boiler's filling pressure.
 9. To be able to carry out the purging process properly, the filling pressure must not fall below the minimum filling pressure.

- Minimum filling pressure: 0.1 MPa (1.0 bar)



Note

The check programme **P.00** runs for 7.5 minutes per circuit.

At the end of the filling process, the filling pressure should be at least 0.02 MPa (0.2 bar) above the counter-pressure of the expansion vessel ("Exp") ($P_{\text{Installation}} \geq P_{\text{Exp}} + 0.02 \text{ MPa (0.2 bar)}$).

10. If there is still too much air in the boiler at the end of the check programme **P.00**, restart the check programme.
11. Check all connections and the entire system for leak-tightness (→ Page 24).
12. Check the expansion relief valve by opening it briefly.
 - ◁ Water escapes from the expansion relief valve.
13. Complete and sign off the Benchmark commissioning check list and then register the guarantee.

7.13 Filling the condensate trap



Danger!

Risk of poisoning due to escaping flue gas.

An empty or insufficiently filled condensate trap may allow flue gas to escape into the room air.

- ▶ Fill the condensate trap with water before starting up the product.

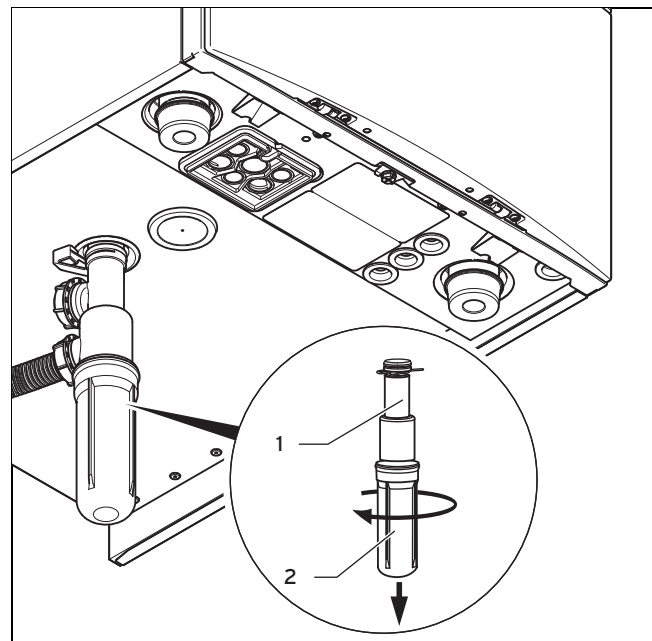

1. Remove the lower section of the condensate trap(2) by unscrewing it from the condensate trap (1).
2. Fill the lower section of the condensate trap with water up to about 10 mm below the upper edge.
3. Secure the lower section of the condensate trap correctly to the condensate trap again.

7 Start-up

7.14 Checking and adjusting the gas setting

7.14.1 Checking the factory setting



Caution.

An incorrect gas group setting may cause operating faults or a reduction in the service life of the product.

If the product design does not match the local gas group, malfunctions will occur or you will have to replace product components prematurely.

- ▶ Before you start up the product, compare the gas group information on the data plate with the gas group available at the installation site.

The product's combustion has been factory tested and is preset for operation with the gas group indicated on the data plate.

Condition: The product design is **not compatible** with the local gas group

If you want to operate the product with liquefied petroleum gas, do not start up the product.

A gas conversion must only be carried out by Vaillant customer service or the manufacturer of the product.

- ▶ Notify Vaillant customer service or the manufacturer of the product that you want a gas conversion carried out.

Condition: The product design is **compatible** with the local gas group

- ▶ Proceed as described below.

7.14.2 Checking the leak-tightness of the flue gas system and for flue gas recirculation

1. Check the flue gas installation is intact in accordance with the latest gas safe technical bulletin and information supplied in the installation instructions.
2. For extended flue gas installations check for flue gas recirculation using the air analysis point.

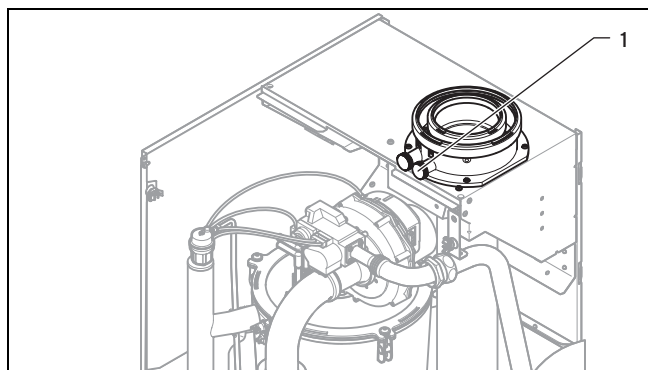

3. Use the air analysis point **(1)** to check for flue gas recirculation.
4. Use a flue gas analyser.
5. If you discover CO or CO₂ in the supply air, search for the leak in the flue gas installation or for signs of flue gas recirculation.
6. Eliminate the damage properly.

7. Check again whether the supply air contains any CO or CO₂.
8. If you cannot eliminate the damage, do not start up the product.

7.14.3 Checking the gas flow rate

The boiler is fitted with a multifunctional automatic gas valve which ensures that the precise air/gas ratio is provided under all operating conditions.

The gas flow rate has been set during production and does not require adjustment. With the front casing fitted check the gas flow rate of the boiler as follows:

- ▶ Start up the product with the check programme **P.01**.
- ▶ Ensure that maximum heat can be dissipated into the heating system by turning up the room thermostat.
- ▶ Wait at least 5 minutes until the boiler has reached its operating temperature.
- ▶ Ensure that all other gas appliances in the property are turned off.
- ▶ Measure the gas flow rate at the gas meter.
- ▶ Compare the measured values with the corresponding values in the table.

Q _{nw} from the data plate	H gas in m ³ /h		
	Nom.	+5 %	-10 %
76.2	8.10	8.51	7.29
95.2	10.10	10.61	9.09
114.3	12.10	12.71	10.89

Condition: Gas flow rate not in the permissible range

- ▶ Check all of the piping and ensure that the gas flow rates are correct.
- ▶ Only put the product into operation once the gas flow rates have been corrected.

Condition: Gas flow rate in the permissible range

- ▶ End the check programme **P.01**.
- ▶ Allow the boiler to cool down by allowing pump overrun to operate for a minimum of 2 minutes.
- ▶ Record the boiler maximum gas flow rate onto the Benchmark gas boiler commissioning checklist.

7.14.4 Checking the gas flow pressure

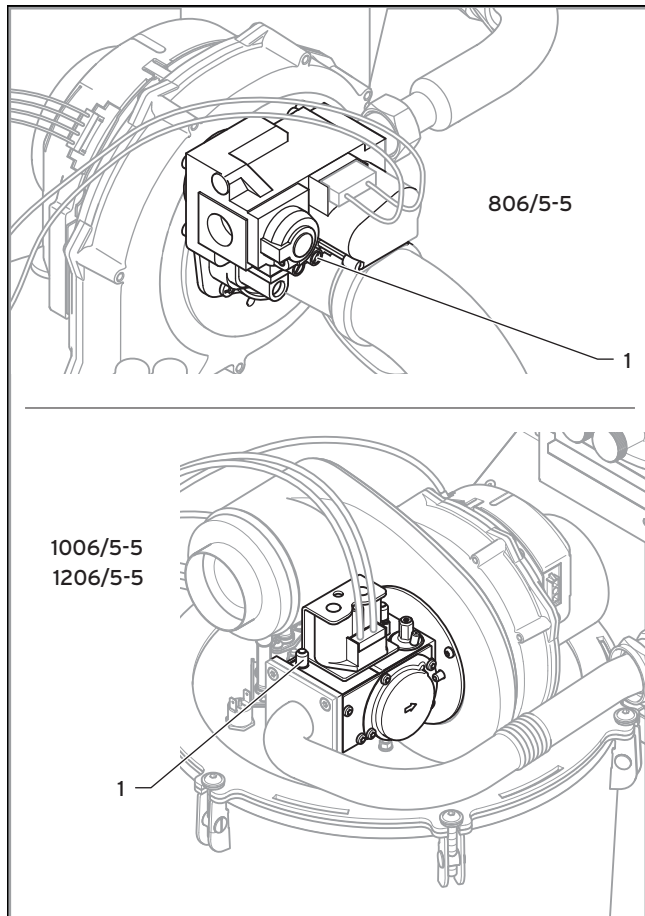

1. Ensure that the gas inlet working pressure can be obtained with all other gas appliances in the property working.
2. Close the gas stopcock.
3. Use a screwdriver to undo the sealing screw of the test nipple **(1)** at the gas valve assembly.
4. Connect a manometer to the test nipple **(1)**.
5. Open the gas stopcock.
6. Start up the product with the check programme **P.01**.
7. In addition, ensure that maximum heat can be dissipated into the heating system by turning up the room thermostat.
8. With the boiler operating at full load check that the gas inlet working pressure at the reference test point **(1)** complies with the requirements.
 - Permissible gas flow pressure for operation with natural gas H: 1.7 to 2.5 kPa (17.0 to 25.0 mbar)
9. Should the pressure recorded at the reference test point in the boiler be lower than indicated check if there is any blockage in the pipework or if the pipework is undersized.

Condition: Gas flow pressure **not** in the permissible range



Caution.

Risk of material damage and operating faults caused by incorrect gas flow pressure.

If the gas flow pressure lies outside the permissible range, this can cause operating faults in and damage to the product.

- ▶ Do not make any adjustments to the product.
- ▶ Check the gas installation.
- ▶ Do not start up the product.

- ▶ If you cannot correct the failure, notify the gas supply company and proceed as follows:
 - ▶ End the check programme **P.01**.
 - ▶ Allow the boiler to cool down by allowing pump overrun to operate for a minimum of two minutes.
 - ▶ Close the gas stopcock.
 - ▶ Remove the pressure gauge and retighten the sealing screw **(1)** for the measuring nipple.
 - ▶ Open the gas stopcock.
 - ▶ Check the test nipple for gas tightness.
 - ▶ Close the gas stopcock.
 - ▶ Install the front casing. (→ Page 10)
 - ▶ Disconnect the product from the power grid.
 - ▶ You must not start up the boiler.

Condition: Gas flow pressure in the permissible range

- ▶ End the check programme **P.01**.
- ▶ Allow the boiler to cool down allowing pump overrun to operate for a minimum of two minutes.
- ▶ Close the gas stopcock.
- ▶ Remove the pressure gauge and retighten the sealing screw **(1)** for the measuring nipple.
- ▶ Open the gas stopcock.
- ▶ Check the test nipple for gas tightness.
- ▶ Install the front casing. (→ Page 10)
- ▶ Reset boiler controls for normal operation.
- ▶ Record the appliance gas inlet working pressure (kPa resp. mbar) in the Benchmark gas boiler commissioning checklist.

7.14.5 Checking the CO₂ content and, if necessary, adjusting it (air index setting)

1. Start up the product with the check programme **P.01**.
2. Wait at least five minutes until the product reaches its operating temperature.

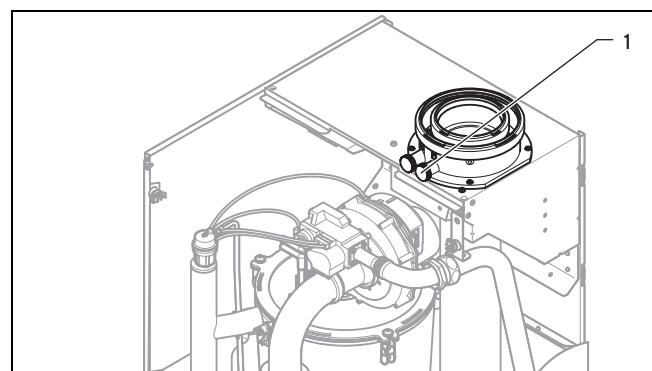

3. Measure the CO₂ and CO/CO₂ content at the flue gas analysis point **(1)**.
4. Compare the measured values with the corresponding values in the table.

7 Start-up

Set values	Unit	Natural gas H
CO ₂ after 5 minutes in full load mode with front casing closed	Vol.-%	9.0 ±1.0
CO ₂ after 5 minutes in full load mode with front casing removed	Vol.-%	8.8 ±1.0
Set for Wobbe index W _s	kWh/m ³	15.0
O ₂ after 5 minutes in full load mode with front casing closed	Vol.-%	4.89 ±1.80
CO content	ppm	≤ 250
CO/CO ₂ content		0.0028

Condition: The CO₂ content must be adjusted

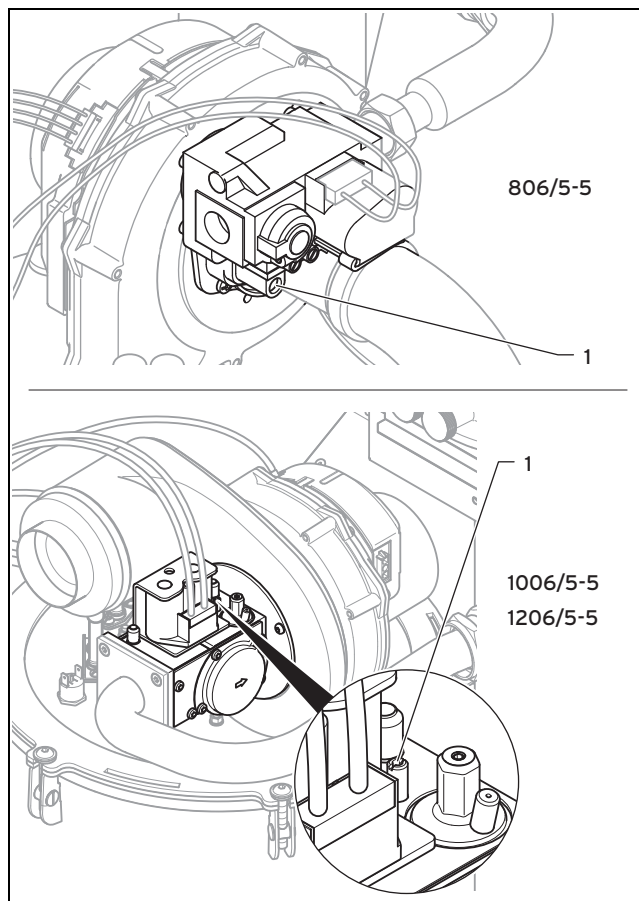

Caution.

Risk of poisoning due to an incorrectly installed gas valve assembly.

If the gas flow pressure is outside the permissible ranges in the table, this may lead to personal injury and material damage.

- ▶ Check the integrity of all gas pipes.
- ▶ Check the flue system for tightness.
- ▶ Check the gas flow pressure.
- ▶ Check the gas flow rate.

- ▶ Break through the sealing sticker.
- ▶ Set the CO₂ content (value with front casing removed) by turning the screw (1).



Note

Turn to the left: Higher CO₂ content
Turn to the right: Lower CO₂ content

- ▶ Only carry out the adjustment in increments of 1/8 turn and wait approximately 1 minute after each adjustment until the value stabilises.



Note

On the VU GB 1006/5-5 and the VU GB 1206/5-5, after changing the direction of rotation, the CO₂ content only changes after approx. 1 turn of the adjusting screw (overcoming the adjustment hysteresis). The adjusting screw must protrude only slightly from the casing.

- ▶ Select (**Cancel**) once the adjustments have been made.
- ▶ If an adjustment is not possible in the specified adjustment range, you must not start up the product.
- ▶ If this is the case, inform Vaillant Customer Service.
- ▶ Install the front casing. (→ Page 10)

7.15 Checking leak-tightness

- ▶ Check the gas pipe, the heating circuit and the hot water circuit for leak-tightness.
- ▶ Check that the flue system has been installed correctly.

7.15.1 Checking the heating mode

1. Make sure that there is a heat requirement.
2. Call up the **Live Monitor**.
 - **Menu** → **Live Monitor**
 - ◁ If the product is working correctly, the display shows **S.04**.

7.15.2 Checking the hot water generation



Danger!

Risk of death from legionella.

Legionella multiply at temperatures below 60 °C.

- ▶ Ensure that the end user is familiar with all of the Anti-legionella measures in order to comply with the applicable regulations regarding legionella prevention.

Condition: Cylinder connected

- ▶ Make sure that the cylinder thermostat is requesting heat.
1. Call up the **Live Monitor**.
 - **Menu** → **Live Monitor**
 - ◁ If the cylinder is charged correctly, the display shows **S.24**.
 2. If you have connected a controller which can be used to set the hot water temperature, set the hot water temperature on the boiler to the maximum possible temperature.

Adapting the unit to the heating installation 8

- Adjust the target temperature for the connected domestic hot water cylinder to the controller.
 - ◀ The boiler adopts the set target temperature which is set on the controller (automatic calibration in newer controllers).
- Set the hot water temperature.

Condition: Water hardness: > 3.57 mol/m³

- Water temperature: ≤ 50 °C

7.16 Thoroughly flushing the heating system ("hot")

- Ensure that the water within the boiler is clean and low in temporary hardness and no system debris can circulate through the boiler during first firing.
- Keep this firing time short and temperature no higher than 50°C as this is just to remove contaminants and not for balancing the system at this time.
- Operate the boiler until the water is up to temperature (max 50 °C).
- Check the heating system for leaks.
- Connect a hose to the drain valve at the boiler.
- Shut off the boiler, open the drain valve and all purge valves and allow the water to flow out of the boiler quickly and fully.
- Close the drain valve.
- Proceed in accordance with the information provided on treating heating water in "Checking and treating the heating water/filling and supplementary water" (→ Page 18).
- Re-fill the boiler in accordance with "Filling and purging the heating installation" (→ Page 21).
- Ensure that the inhibitor levels are correctly maintained throughout the boiler's operational life.



Note

The actual reading on the digital pressure gauge should ideally be 0,05 MPa (0,5 bar) plus an additional pressure corresponding to the highest point of the system above the base of the boiler – 10 m head equals an additional 1 bar reading on the pressure gauge. The minimum pressure should not be less than 0,1 MPa (1 bar) in any installation. If the system is to be treated with an inhibitor it should be applied at this stage in accordance with the manufacturer's instructions. Further information can be found regarding inhibitor treatment in "Checking and treating the heating water/filling and supplementary water" (→ Page 18).

- Install the side section. (→ Page 11)
- Install the front casing. (→ Page 10)

8 Adapting the unit to the heating installation

To reset the most important system parameters, use the **Unit configuration** menu item.

Menu → **Installer level Unit configuration**

Or manually relaunch the installation assistant.

Menu → **Installer level** → **Start inst. assistant**

8.1 Calling up diagnostics codes

The settings options for more complex systems can be found in the **Diagnostics menu**.

Menu → **Installer level Diagnostics menu**

Overview of diagnostics codes (→ Page 39)

Using the parameters that are marked as adjustable in the overview of diagnostics codes, you can adapt the product to the heating installation and the needs of the customer.

- ▶ Press or to change the diagnostics code.
- ▶ Press (**Select**) to select the parameter to change.
- ▶ Press or to change the current setting.
- ▶ Press (**OK**) to confirm your selection.

8.2 Setting the partial heat load

The partial heat load of the product is set to **Auto** at the factory. If you still want to set a fixed maximum partial heat load, you can set a value under **D.000**, which equates to the product output in kW.

If the product is operated in cascade, you must increase the offset for the minimum fan speed of the unit to the **fixed value** 1500 rpm (**D.050**) when operating it with **natural gas** and you must never raise the speed under **D.050** any higher when operating it with **liquefied petroleum gas** because a higher speed is already being used.

If a domestic hot water cylinder (cylinder type VIH) is installed, you can adjust the partial load setting for the cylinder charging to the cylinder type (**D.077**).

8.3 Setting the pump overrun

You can set the pump overrun under **D.001** (factory setting: 5 min.).



Note

The internal pump's operating mode is set to **Comfort** at the factory. The pump is switched on when the heating flow temperature is not at **Heating off** (→ Operating instructions) and the heat requirement is enabled via an external control. You must not change the factory setting under **D.018!**

8.4 Setting the maximum flow temperature

You can set the maximum flow temperature for the heating mode under **D.071** (default setting: 75 °C).

8 Adapting the unit to the heating installation

8.5 Setting the return temperature control system

If the product is connected to an underfloor heating system, the temperature control can be changed from flow temperature control (factory setting) to return temperature control under **D.017**. If you have activated the return temperature control under **D.017**, the automatic heating output determination function is not active. If you set **D.000** to **Auto** anyway, the product operates with the maximum possible partial heat load.

8.6 Burner anti-cycling time

8.6.1 Setting the burner anti-cycling time

To prevent frequent switching on and off of the burner and thus prevent energy losses, an electronic restart lockout is activated for a specific period each time the burner is switched off. You can adjust the burner anti-cycling time to the conditions of the heating installation. The burner anti-cycling time is only active for the heating mode. You can set the maximum burner anti-cycling time under **D.002** (default setting: 20 min.). The effective burner anti-cycling times with respect to the target flow temperature and the maximum set burner anti-cycling time can be found in the following table:

T _{Flow} (target) [°C]	Set maximum burner anti-cycling time [min]						
	1	5	10	15	20	25	30
30	2.0	4.0	8.5	12.5	16.5	20.5	25.0
35	2.0	4.0	7.5	11.0	15.0	18.5	22.0
40	2.0	3.5	6.5	10.0	13.0	16.5	19.5
45	2.0	3.0	6.0	8.5	11.5	14.0	17.0
50	2.0	3.0	5.0	7.5	9.5	12.0	14.0
55	2.0	2.5	4.5	6.0	8.0	10.0	11.5
60	2.0	2.0	3.5	5.0	6.0	7.5	9.0
65	2.0	1.5	2.5	3.5	4.5	5.5	6.5
70	2.0	1.5	2.0	2.5	2.5	3.0	3.5
75	2.0	1.0	1.0	1.0	1.0	1.0	1.0

T _{Flow} (target) [°C]	Set maximum burner anti-cycling time [min]					
	35	40	45	50	55	60
30	29.0	33.0	37.0	41.0	45.0	49.5
35	25.5	29.5	33.0	36.5	40.5	44.0
40	22.5	26.0	29.0	32.0	35.5	38.5
45	19.5	22.5	25.0	27.5	30.5	33.0
50	16.5	18.5	21.0	23.5	25.5	28.0
55	13.5	15.0	17.0	19.0	20.5	22.5
60	10.5	11.5	13.0	14.5	15.5	17.0
65	7.0	8.0	9.0	10.0	11.0	11.5
70	4.0	4.5	5.0	5.5	6.0	6.5
75	1.0	1.0	1.0	1.0	1.0	1.0



Note

The remaining burner anti-cycling time following a regular shutdown in heating mode can be called up under **D.067**.

8.6.2 Resetting the remaining burner anti-cycling time

1st option

Menu → Reset anti-cycling time

The current burner anti-cycling time appears in the display.

- ▶ Confirm the burner anti-cycling time reset by pressing (**Select**).

2nd option

- ▶ Press the reset button.

8.7 Setting the maintenance interval

If you set the maintenance interval, the message that the product must be serviced appears in the display, together with the maintenance symbol , after a configurable number of burner operating hours. The display on the eBUS control shows the information **Maintenance MAIN**.

- ▶ Set the operating hours until the next maintenance work is due using **D.084**. You can set the operating hours in increments of ten from 0 to 3010 h (hours).

If you do not set a numerical value, but instead set the symbol "-", the "**Maintenance display**" function is not active.



Note

On completion of the set operating hours, you must set the maintenance interval again.

8.8 Pump output (high-efficiency pump)

The product can be equipped with a pump group with a high-efficiency pump (accessories). The pump is fully modulating and is actuated according to the heat requirement.

The remaining feed head of this pump group is designed so that the full heat output is transported as far as the system separation.

Remaining feed head

The following values apply for a pump speed target value ≥ 85%:

Unit output	80 kW	100 kW	120 kW
Circulation water volume at maximum heat input ($\Delta T=23$ K)	2.99 m ³ /h	3.74 m ³ /h	4.49 m ³ /h
Water pressure downstream of the boiler at maximum water flow rate, with non-return valve	0.065 MPa (0.650 bar)	0.053 MPa (0.530 bar)	0.042 MPa (0.420 bar)
Water pressure downstream of the boiler at maximum water flow rate, without non-return valve	0.073 MPa (0.730 bar)	0.061 MPa (0.610 bar)	0.050 MPa (0.500 bar)

Adapting the unit to the heating installation 8

80 kW boiler with high-efficiency pump

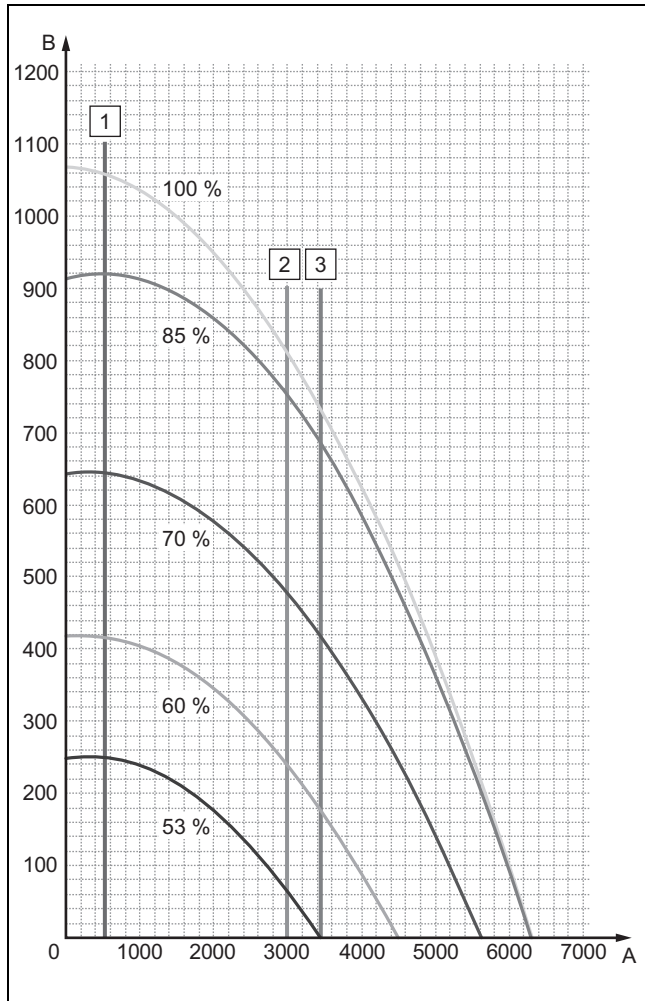

- | | | | |
|---|---|---|---|
| 1 | Circulation water volume at minimum heat input | 3 | Circulation water volume at maximum heat input ($\Delta T=20$ K) |
| 2 | Circulation water volume at maximum heat input ($\Delta T=23$ K) | A | Circulation water volume [l/h] |
| | | B | Remaining feed head [mbar] |

100 kW boiler with high-efficiency pump

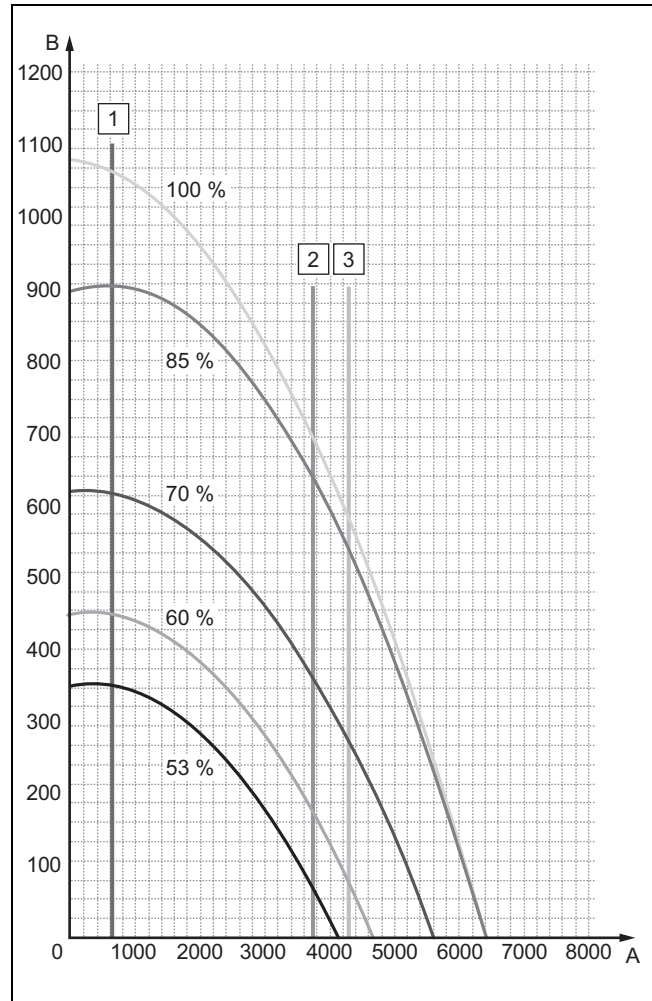

- | | | | |
|---|---|---|---|
| 1 | Circulation water volume at minimum heat input | 3 | Circulation water volume at maximum heat input ($\Delta T=20$ K) |
| 2 | Circulation water volume at maximum heat input ($\Delta T=23$ K) | A | Circulation water volume [l/h] |
| | | B | Remaining feed head [mbar] |

9 Inspection and maintenance

120 kW boiler with high-efficiency pump

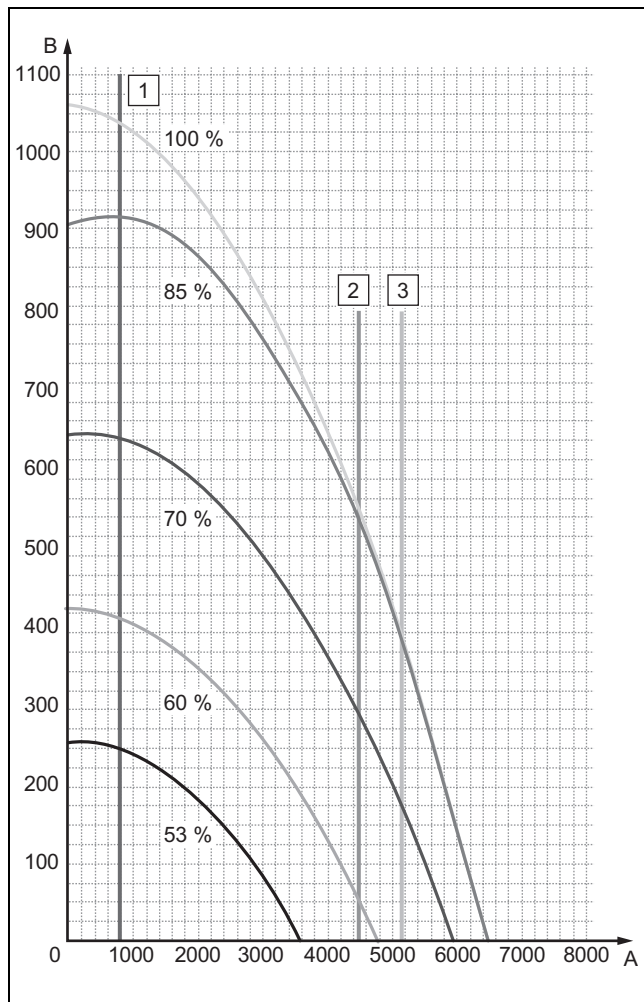

- | | | | |
|---|---|---|---|
| 1 | Circulation water volume at minimum heat input | 3 | Circulation water volume at maximum heat input ($\Delta T=20$ K) |
| 2 | Circulation water volume at maximum heat input ($\Delta T=23$ K) | A | Circulation water volume [l/h] |
| | | B | Remaining feed head [mbar] |

8.9 Handing the product over to the end user

- When you have finished the installation, attach the sticker supplied (835593) to the front of the product in the user's language.
- Explain to the end user how the safety devices work and where they are located.
- Inform the end user how to handle the product. Answer any questions the end user may have. In particular, draw attention to the safety warnings which the end user must follow.
- Inform the end user that they must have the product maintained in accordance with the specified intervals.
- Pass all of the instructions and documentation for the product to the end user for safe-keeping.
- Inform the end user about measures taken to ensure the combustion air supply and flue system, and instruct the end user that he must not make any changes.

9 Inspection and maintenance

Auxiliary service equipment:

You require the following tool for the inspection and maintenance:

- WAF 8 socket spanner with extension
- Torx screwdriver 20, 25 and 30
- 5 mm hex key

- ▶ Carry out all inspection and maintenance work in the order shown in the table "Overview of inspection and maintenance work".

9.1 Observing inspection and maintenance intervals



Warning.

Risk of injury and a risk of material damage caused by negligent inspection and maintenance work.

Negligence in inspection and maintenance work, as well as failure to comply with the specified inspection and maintenance intervals, may impair the operational safety of the product and lead to injuries and material damage.

- ▶ Instruct the end user that the prescribed inspection and maintenance intervals must be complied with as a minimum requirement.
- ▶ Carry out a regular inspection once a year.
- ▶ Carry out regular maintenance work in line with the findings from the inspection. The maintenance interval must not be longer than two years.



Warning.

Risk of injury and death due to improper inspection and maintenance!

Improper performance of inspections and maintenance work may result in leaks or even an explosion.

- ▶ Inspection and maintenance work on the product must only be carried out by professionally qualified persons.

Any customer service work must be carried out by a professionally qualified person in accordance with the safety, installation and operating provisions for gas-fired units. Professional qualification must be confirmed by an adequately recognised organisation or public office.



Note

The person who carries out a combustion measurement must be trained in the use of a flue gas measuring instrument and in interpreting the results. The flue gas measuring instrument that is used must be calibrated in accordance with the specifications of the measuring instrument manufacturer. The correct fuel type must be set on the flue gas measuring instrument.

Inspection

The inspection is intended to determine the actual condition of the product and compare it with the target condition. This is done by measuring, checking and observing.

Maintenance

Maintenance is required in order to eliminate any deviations of the actual condition from the target condition. This is normally done by cleaning, setting and, if necessary, replacing individual components that are subject to wear.

As the competent person, you determine the maintenance intervals (at least once every two years) and their scope based on the how you define the condition of the product during the inspection. Carry out all inspection and maintenance work in the sequence shown in Appendix C.

9.2 Procuring spare parts

The original components of the product were also certified by the manufacturer as part of the declaration of conformity. If you use other, non-certified or unauthorised parts during maintenance or repair work, this may void the conformity of the product and it will therefore no longer comply with the applicable standards.

We strongly recommend that you use original spare parts from the manufacturer as this guarantees fault-free and safe operation of the product. To receive information about the available original spare parts, contact the contact address provided on the back page of these instructions.

- ▶ If you require spare parts for maintenance or repair work, use only the spare parts that are permitted for the product.

9.3 Using the function menu

The function menu allows you to actuate and test individual components in the heating installation.

Menu → Installer level → Test programmes → Function menu

- ▶ Choose the heating installation components.
- ▶ Press **(Select)** to confirm your selection.

Display	Test programme	Action
T.01	Check boiler circulation pump	Switch the boiler circulation pump on and off.
T.03	Check fan	Switch the fan on and off. The fan runs at maximum rotational speed.
T.04	Check cylinder charging pump	Switch the cylinder charging pump on and off.
T.05	Check circulation pump	Switch the circulation pump on and off.

Display	Test programme	Action
T.06	Check external pump	Switch the external pump on and off.
T.08	Checking the burner	The product starts up and switches to minimum load. The flow temperature is shown in the display.

Terminate function menu

- ▶ To terminate the function menu, select **(Cancel)**.

9.4 Carrying out electronics self-tests

Menu → Installer level → Test programmes → Electronics self-test

You can use the electronics self-test to check the PCB in advance.

9.5 Removing the gas-air mixture unit



Note

The gas-air mixture unit consists of four main components:

- Speed-regulated fan,
- Air intake pipe,
- Gas valve assembly,
- Burner

1. Switch off the product using the on/off button.
2. Disconnect the product from the power grid.
3. Close the gas stopcock.
4. Remove the front casing. (→ Page 10)
5. Remove the upper casing. (→ Page 10)

Condition: Applies for 80 kW

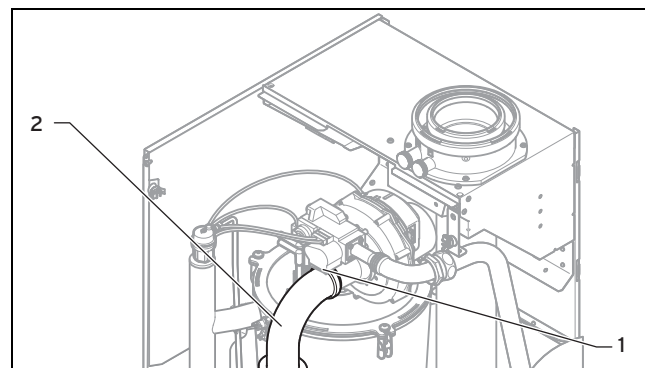

- ▶ Undo the clip **(1)** on the air intake pipe **(2)**, and remove the air intake pipe from the intake stub.

9 Inspection and maintenance

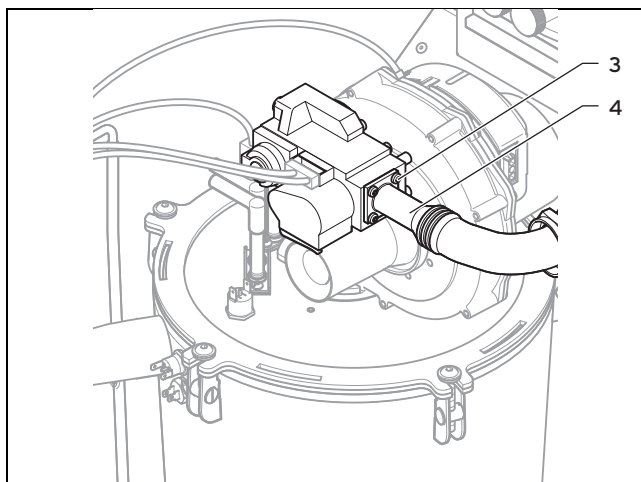

- ▶ Undo the four screws on the flange connection (3) to the gas valve assembly.

Condition: Applies for 100 kW and 120 kW

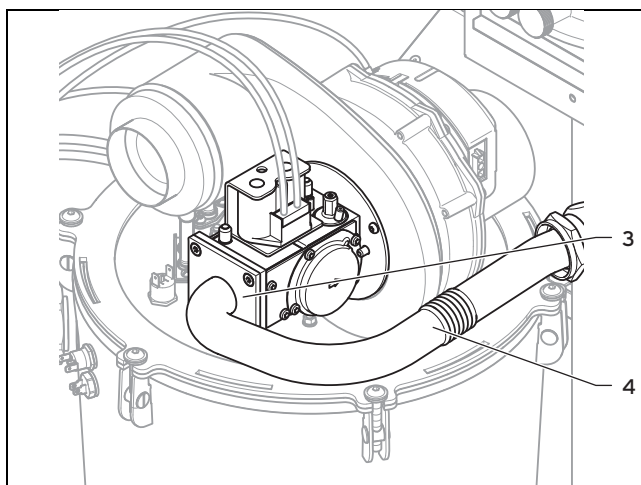

- ▶ Undo the four screws on the flange connection (3) to the gas valve assembly.
6. Move the gas pipe (4) to the side.

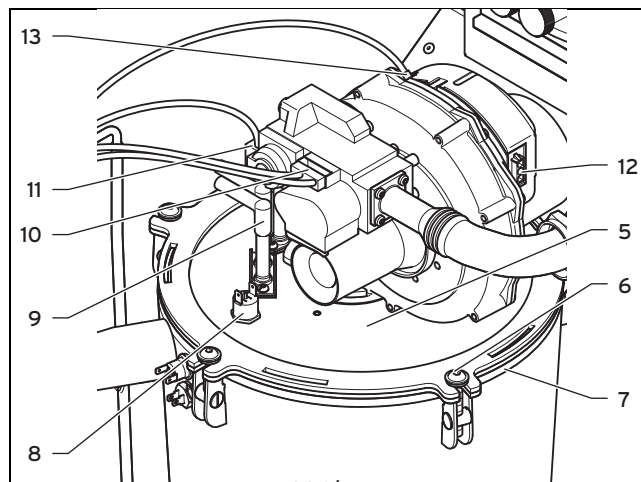

806/5-5

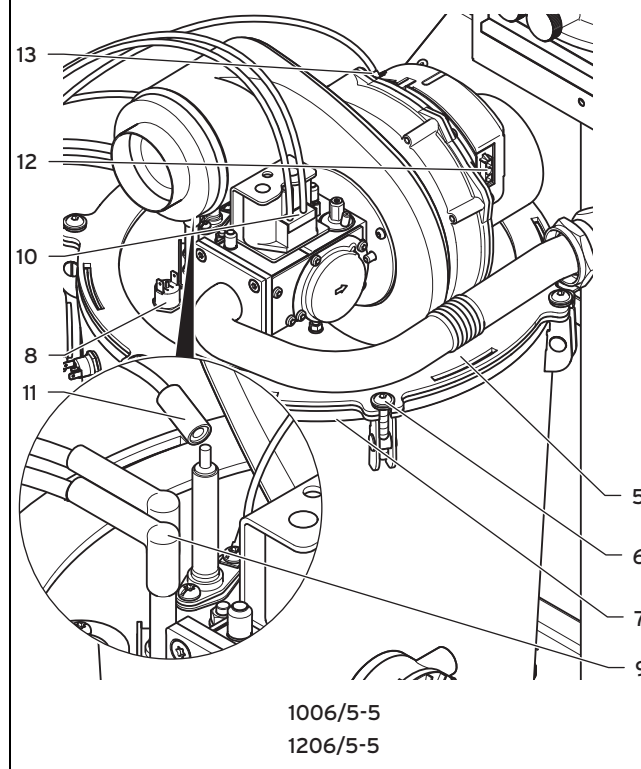

1006/5-5
1206/5-5



Danger!

Risk of poisoning and fire caused by escaping gas!

The gas pipe may become damaged.

- ▶ Ensure that you do not damage the seals on the gas pipe when removing and installing the gas-air mixture unit.

- Remove the ionisation line plug from the ionisation electrode (11), and remove the earth connection plug from the earthing lug.
- Remove the ignition line plug and the earth connection for the ignition electrode (9) from the ignition transformer.



Note

The cable is firmly connected to the ignition electrode.

9. Remove the plugs (12) and (13) from the fan motor by pushing in the latching lug.
10. Remove the plug from the gas valve assembly (10).
11. Remove the plug from the upper safety cut-out (8).
12. Undo the screws (6) on the burner door.
13. Remove the complete gas-air mixture unit (5) from the heat exchanger (7).
14. Check the burner and the heat exchanger for damage and dirt.

9.6 Cleaning the heat exchanger

1. Protect the electronics box against sprayed water.

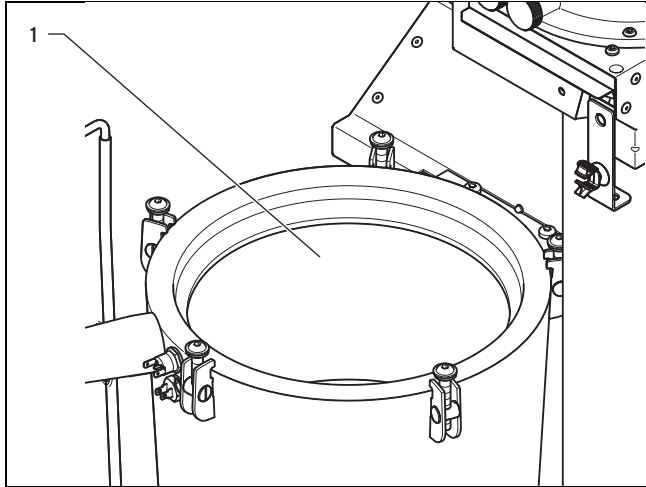

2. Remove the lower section of the condensate trap to ensure that any existing condensate neutraliser does not become damaged.
3. Rinse away any loose dirt in the heat exchanger (1) with a sharp jet of water or use a plastic brush.
 - ◁ The water flows out of the heat exchanger through the drain.
4. Install the condensate trap.

9.7 Checking the burner

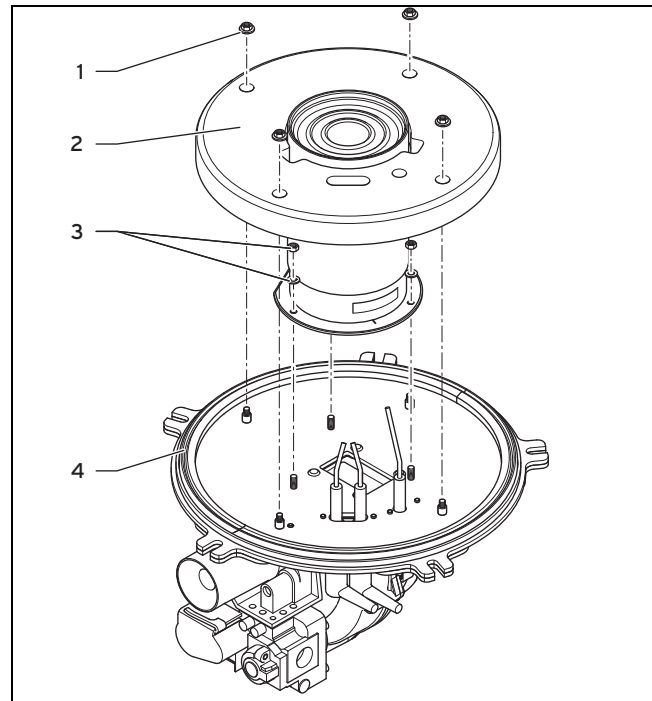

1. Check the surface of the burner for damage. If you notice any damage, replace the burner, including the seal (→ Page 35).
2. Check the insulating mat (2) on the burner door. If you notice any signs of damage, replace the insulating mat (→ Page 35).

9.8 Replacing the ignition and ionisation electrodes

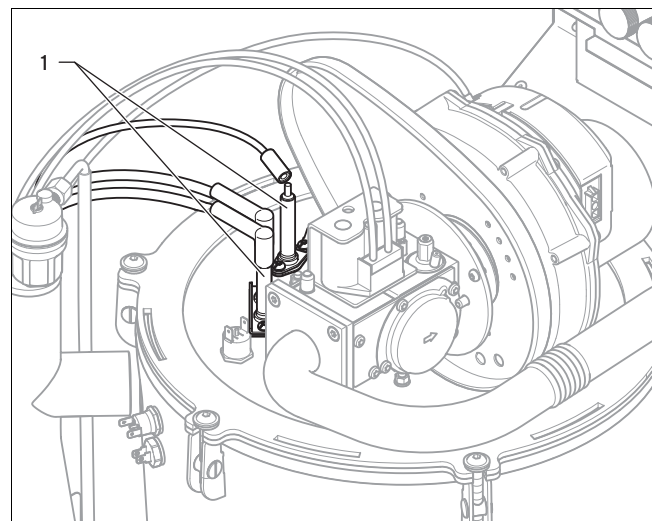

Caution.

Risk of material damage caused by damage to the ignition and ionisation electrodes.

The electrodes may become damaged during installation.

- Install the new electrodes only after first installing the gas-air mixture unit.

9 Inspection and maintenance

1. Remove the electrodes (1) from the burner door from above.
2. Insert the new electrodes with new seals.
 - Torque: 2.8 Nm

9.9 Cleaning the condensate trap

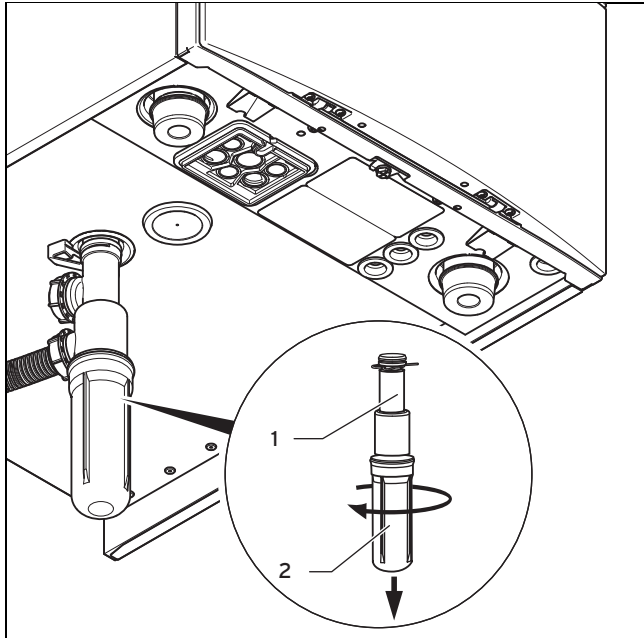

1. Remove the lower section of the condensate trap(2) by unscrewing it from the condensate trap (1).
2. Flush out the lower section of the condensate trap with water.
3. Fill the lower section of the condensate trap with water up to about 10 mm below the upper edge.
4. Secure the lower section of the condensate trap to the condensate trap again.

9.10 Installing the gas-air mixture unit

1. Replace the seal in the burner door.
2. Ensure that the bracket for the insulating mat is installed properly again after it is replaced.
3. Replace all seals at the sealing points opened during the maintenance work.

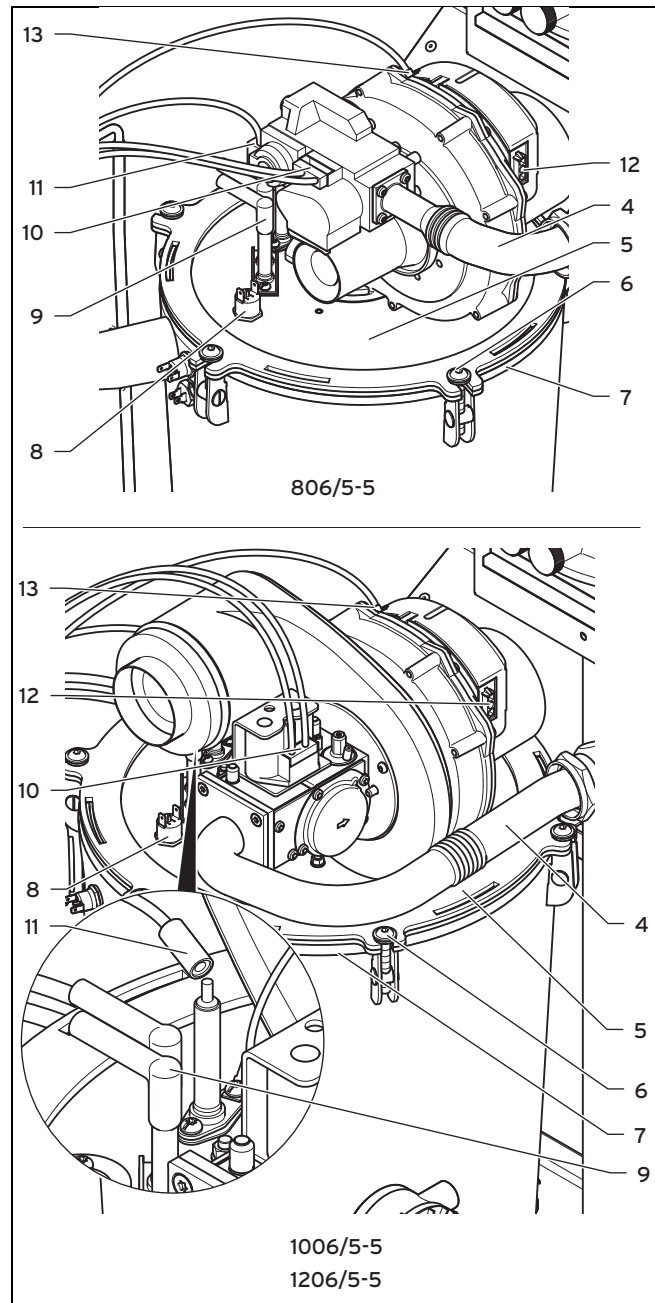

4. Connect the gas-air mixture unit (5) to the heat exchanger (7).
5. Tighten the screws (6) in a cross-wise pattern until the burner door fits closely and uniformly onto the mating surfaces.
 - Torque: 10 Nm
6. Connect the ignition line plug and the earth connection for the ignition electrodes (9) to the ignition transformer.
7. Connect the ionisation line plug to the ionisation electrode (11) and connect the earth connection plug to the earthing lug.
8. Connect the safety cut-out plug to the upper safety cut-out (8).
9. Connect the plugs (12) and (13) to the fan motor.
10. Connect the plug (10) to the gas valve assembly.
11. Connect the gas pipe (4) with a new seal to the gas valve assembly.

Condition: Applies for 80 kW

- Torque: 2 Nm

Condition: Applies for 100 kW and 120 kW

- Torque: 2.8 Nm



Warning.
Risk of poisoning and fire caused by escaping gas!

Gas can escape through leaks.

- ▶ Check the gas tightness at the gas connection using leak detection spray.

12. Open the gas stopcock on the product.

Condition: Applies for 80 kW

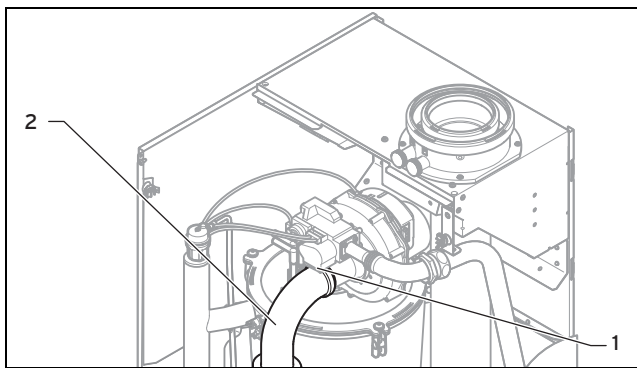

- ▶ Check that the sealing ring in the air intake pipe (2) is positioned correctly in the seal seat.
 - ▶ Reconnect the air intake pipe to the intake stub.
 - ▶ Secure the air intake pipe with the clip (1) on the intake stub.
13. Close the electronics box.
14. Install the front casing. (→ Page 10)
15. Re-establish the connection to the power grid.

9.11 Draining the product

1. Switch off the product using the on/off button.
2. Close the service valves of the product.
3. Start the check programme **P.06**.
4. Open the drain valves.
5. Check the water for clouding and additives and correct this if required.

9.12 Completing inspection and maintenance work

Once you have completed all maintenance work:

- ▶ Check the gas flow pressure. (→ Page 23)
- ▶ Check the CO₂ content and, if necessary, adjust it (air index setting). (→ Page 23)

10 Troubleshooting

You can find an overview of the fault codes in the appendix.

Overview of fault codes (→ Page 43)

10.1 Contacting your service partner

If you contact your Vaillant service partner, if possible, please mention

- the fault code that is displayed (**F.xx**),
- the product status (**S.xx**) that is displayed on the Live Monitor (→ Page 18).

10.2 Calling up service messages

If the maintenance symbol appears in the display, there is a service message.

The maintenance symbol appears if you have set a maintenance interval, for example, and it has elapsed. The product is not in fault mode.

- ▶ To obtain more information about the service message, call up the **Live monitor** (→ Page 18).

Condition: S.44-S.48 is displayed

The product is in Comfort protection mode. The product continues to run with restricted comfort after it has detected a fault.

- ▶ To establish whether or not a component is defective, read the fault memory (→ Page 33).



Note

If no fault message is present, the product will automatically switch back to normal operating mode after a certain time.

10.3 Reading off the fault codes

If a fault develops in the product, the display shows a fault code **F.xx**.

Fault codes have priority over all other displays.

If multiple faults occur at the same time, the display shows the corresponding fault codes for two seconds each in sequence.

- ▶ Rectify the fault.
- ▶ To restart the product, press the fault clearance key (Operating instructions).
- ▶ If you are unable to remedy the fault and the fault recurs despite several fault clearance attempts, contact Vaillant Service.

10.4 Querying the fault memory

Menu → Installer level Fault list

The product has a fault memory. You can use this to query the last ten faults that occurred in chronological order.

The display shows:

- The number of faults that have occurred
 - The fault currently selected with fault number **F.xx**
 - A plain text display explaining the fault.
- ▶ You can display the last ten faults that have occurred by pressing or .

10 Troubleshooting

Overview of fault codes (→ Page 43)

10.5 Resetting the fault memory

- ▶ To delete the entire fault list, press  (Delete, OK) twice.

10.6 Performing diagnostics

- ▶ You can use the function menu (→ Page 29) to actuate and test individual components of the product in the fault diagnostics.

10.7 Using check programmes

You can also use check programmes (→ Page 20) for troubleshooting.

10.8 Resetting parameters to factory settings

- ▶ To reset all parameters simultaneously to the default settings, set **D.096** to **1**.

10.9 Preparing the repair work

1. Decommission the product.
2. Disconnect the product from the power mains.
3. Remove the front casing.
4. Close the gas isolator cock.
5. Close the service valves in the heating flow and in the heating return.
6. Close the service valve in the cold water pipe.
7. Drain the product if you want to replace water-bearing components of the product.
8. Make sure that water does not drip on live components (e.g. the electronics box).
9. Use only new seals.

10.10 Replacing defective components

10.10.1 Replacing the gas valve assembly

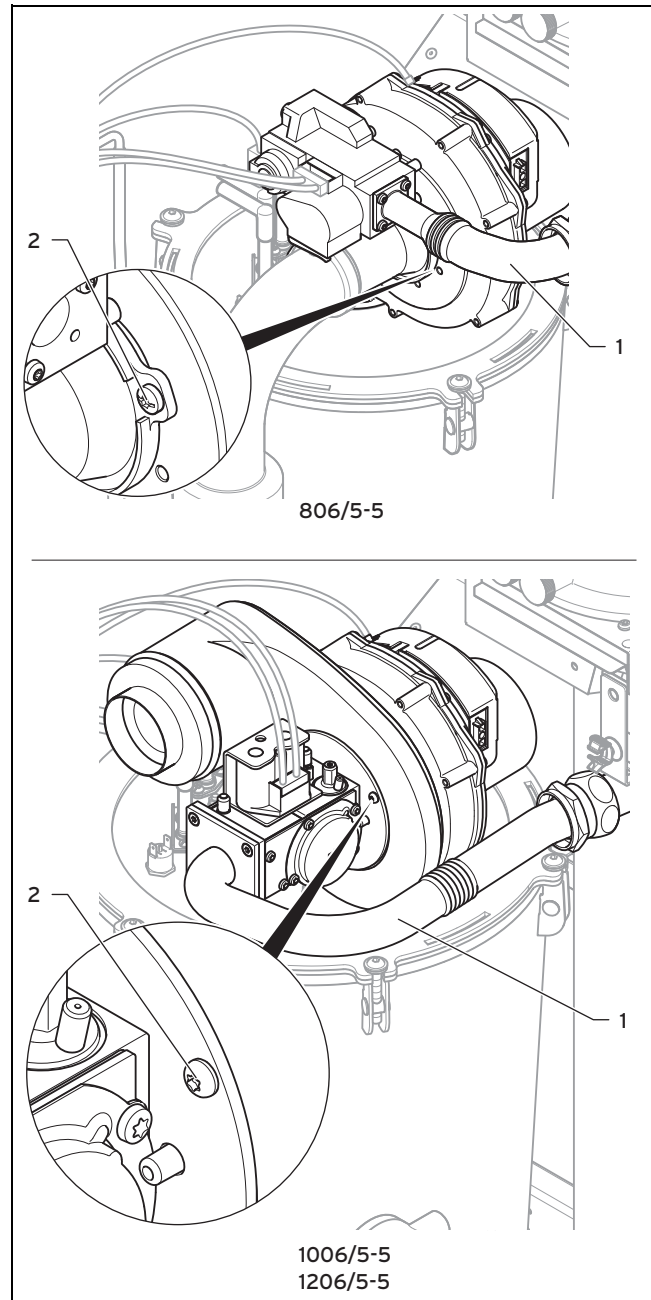

1. Remove the gas pipe **(1)** from the gas valve assembly.
2. Unscrew the screws **(2)** from the fan and remove the gas valve assembly from the fan.
3. Replace the defective component.
4. Install the gas valve assembly and the fan in the same position as before. Use new seals for this.
5. Tighten the screws **(2)** in a cross-wise pattern.

Condition: Applies for 80 kW

- Torque: 5.5 Nm

Condition: Applies for 100 kW and 120 kW

- Torque: 2 Nm

6. First, screw the gas pipe loosely onto the gas valve assembly. Only after completing the installation work should you tighten the screws for the flange fastening on the gas valve assembly.

- After installing the new gas valve assembly, carry out a leak-tightness test (→ Page 24), and set the gas setting (→ Page 22).

10.10.2 Replacing the burner

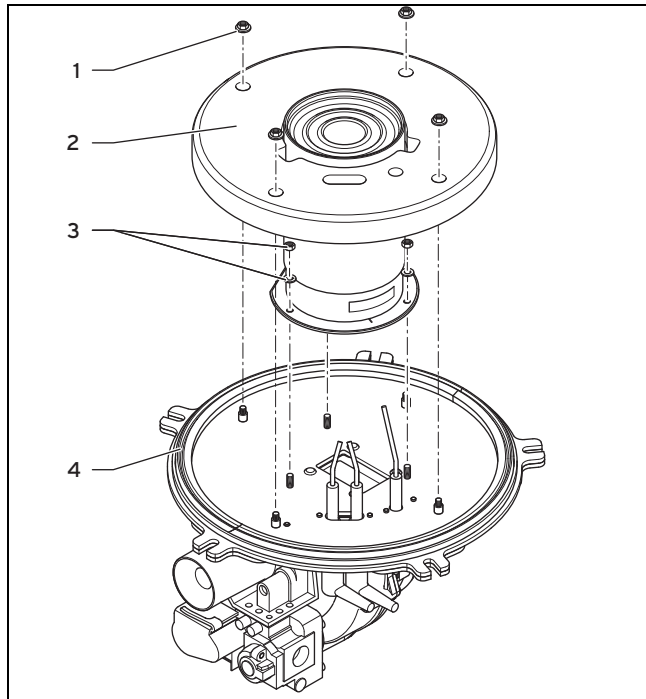

- Remove the gas-air mixture unit. (→ Page 29)
- Remove the ignition and monitoring electrode.
- Remove the seal (4) from the burner door.
- Undo the four nuts (1) that are used to secure the insulating mat.
- Remove the insulating mat (2).
- Undo the nuts (3) on the burner.



Note

Use a suitable socket spanner (with extension) to ensure that the burner mat does not become damaged. You must not use burners that have a damaged mat.

- Remove the burner. When doing so, hold the fan and the burner door securely.
- Fit the new burner with a new seal.
- Use all of the nuts and washers (3) to secure the burner.
 - Torque: 4 Nm
- Use four nuts (1) to secure the insulating mat. Ensure that the insulating mat is touching the burner door and the cut-outs for the insulating mat lie above the cut-outs for the burner door.
 - Torque: 6 Nm
- Install the ignition and monitoring electrodes. Use new seals for this.

- Torque: 2.8 Nm

- Install the gas-air mixture unit. (→ Page 32)
- Check that the product functions correctly and check the leak-tightness (→ Page 24).

10.10.3 Replacing the insulating mat

If the safety cut-out on the burner door has been triggered, the insulating mat between the burner door and burner room may be damaged.

- Check and replace the insulating mat.



Note

To replace the insulating mat, proceed in the same way as when removing the burner. It is not necessary to remove the burner.

10.10.4 Replacing the fan

- Remove the gas-air mixture unit. (→ Page 29)

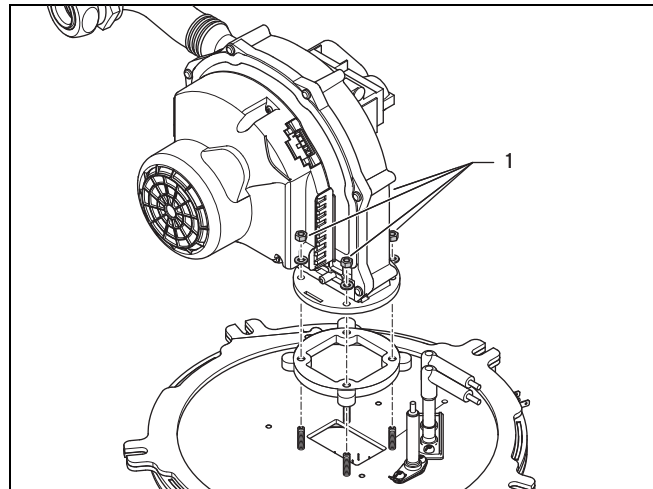

- Undo the four nuts (1) on the fan.
- Install the new fan on the burner door in the same orientation in which it was previously positioned.

Condition: Applies for 80 kW and 100 kW

- Torque: 3.5 Nm

Condition: Applies for 120 kW

- Torque: 6 Nm



Note

Tighten the screws on the fan evenly. The fan must not be at an angle.

10.10.5 Replacing the heat exchanger

- Drain the product. (→ Page 33)
- Remove the gas-air mixture unit. (→ Page 29)
- Unscrew the flow and return line in the front area of the underside of the product.

11 Decommissioning

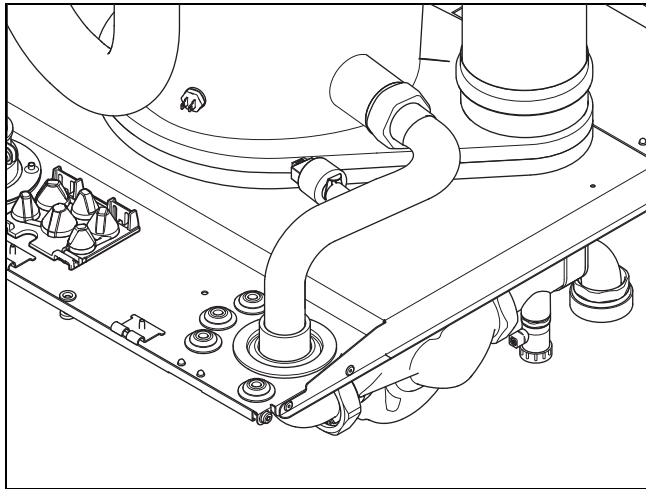

4. Release the sealing collars on the flow and return pipe from the floor plate.

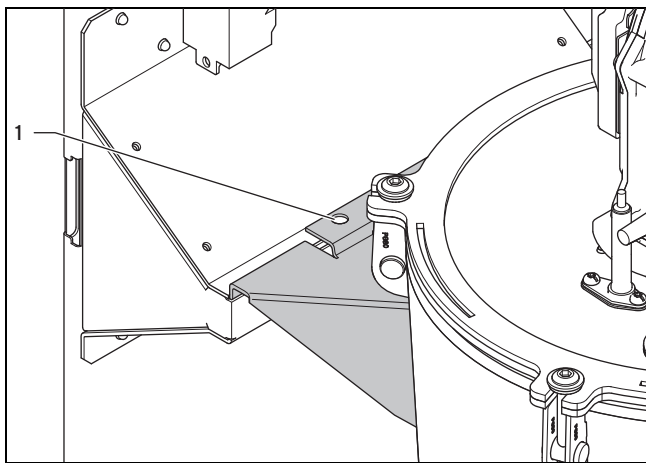

5. Remove the screws (1) from the heat exchanger bracket.
6. Lift the heat exchanger out of its bracket (this requires two people). The pipes can be used as handles for this.
7. Install the new heat exchanger in reverse order.
8. Install the gas-air mixture unit. (→ Page 32)
9. Fill and purge the product and, if necessary, the heating installation.

10.10.6 Replacing the PCB and/or the display



Caution.
Risk of material damage caused by incorrect repairs.

Using an incorrect replacement display may cause damage to the electronics.

- ▶ Before replacing, check that the correct replacement display is available.
- ▶ Never use another replacement display.



Note
If you are replacing only one component, the set parameters are transferred automatically. When the product is switched on, the new component adopts the previously set parameters from the unreplaced component.

1. Disconnect the unit from the power grid and secure it against being switched back on again.

Condition: Replacing the display or PCB

- ▶ Replace the PCB or display according to the assembly and installation instructions supplied.

Condition: Replacing the PCB and display at the same time

- ▶ Select the required language.
 - ◀ If you are replacing both components at the same time, the product switches directly to the menu to select the language after switching on. The factory-set language setting is English.
- ▶ Confirm your setting by pressing **(OK)**.
 - ◀ You are automatically taken to **D.093** to set the device specific number.
- ▶ Select the correct value for the relevant product type in accordance with the following table.

Device Specific Numbers (DSN - Device Specific Number) for the product types

	Product type number
806 (VU GB 806/5-5)	82
1006 (VU GB 1006/5-5)	81
1206 (VU GB 1206/5-5)	80

- ▶ Confirm your setting.
 - ◀ The electronics are now set to the product type and the parameters of all diagnostics codes are set to factory settings.
 - ◀ The display automatically restarts with the installation assistant.
- ▶ Make the system-specific settings.

10.11 Completing repair work

- ▶ Check the product for tightness (→ Page 24).

11 Decommissioning

11.1 Decommissioning the product

- ▶ Switch off the product.
- ▶ Disconnect the product from the power grid.
- ▶ Close the gas stopcock.
- ▶ Close the cold-water isolation valve.
- ▶ Drain the product. (→ Page 33)

12 Recycling and disposal

Disposing of the packaging

- ▶ Dispose of the packaging correctly.
- ▶ Observe all relevant regulations.

13 Customer service

To ensure efficient and reliable operation of your boiler it is recommended that regular servicing is carried out by your service provider.

Appendix

A Installer level menu structure – Overview

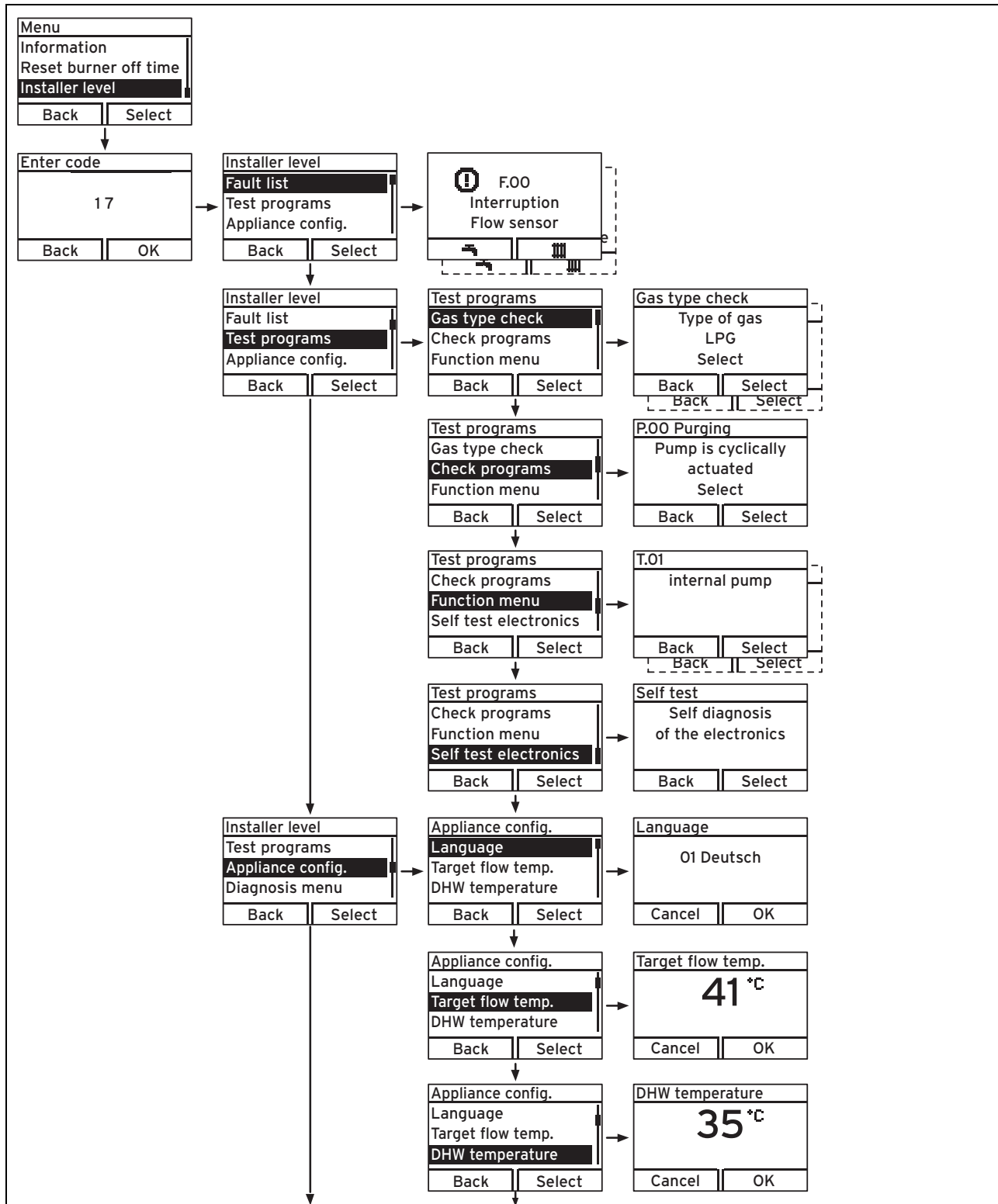

Note

The menu entry **Menu → Installer level → Test programmes → Gas family check** is not working.

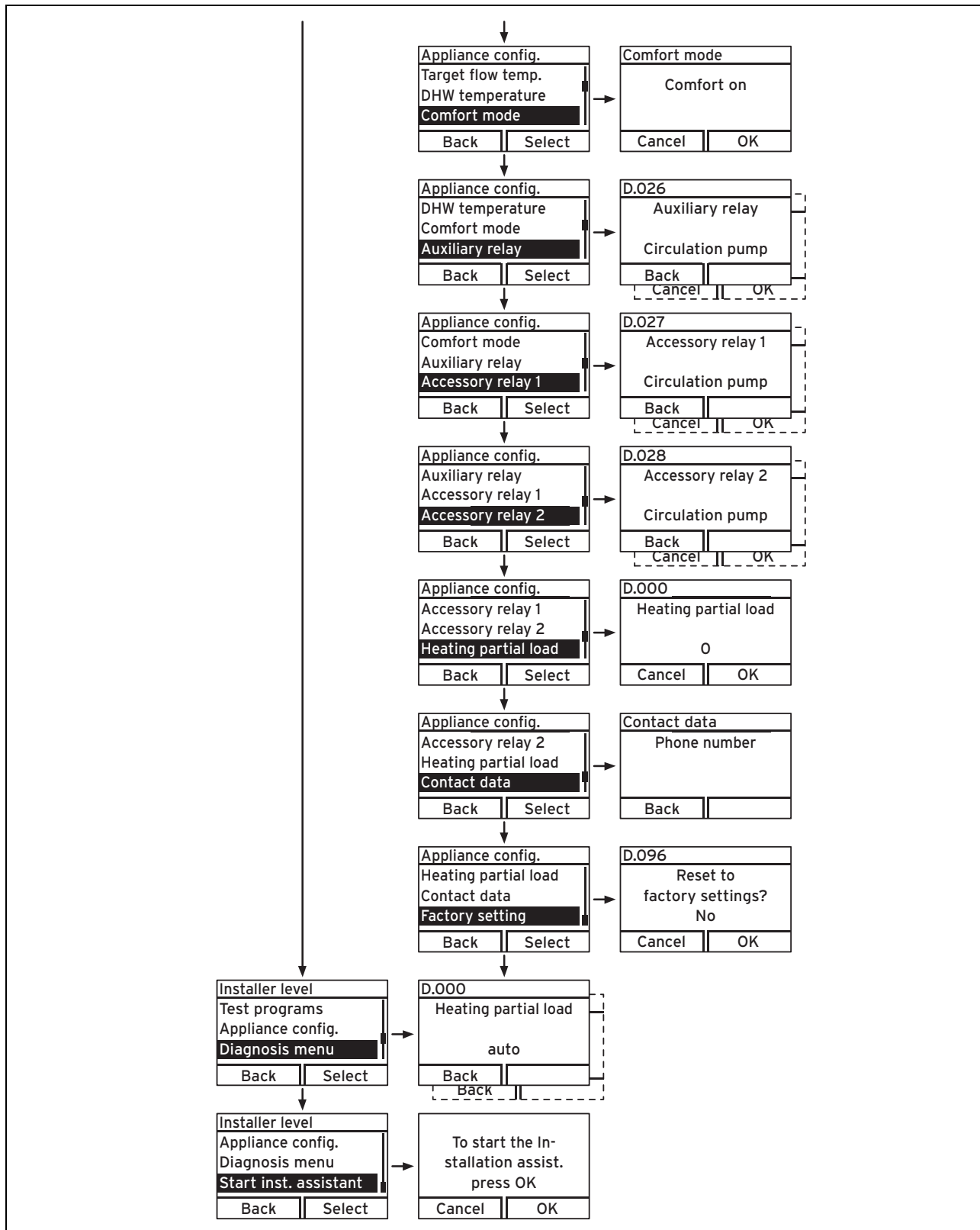

B Overview of diagnostics codes

Code	Parameter	Values or explanations	Default setting	Own setting
D.000	Partial heating load	Adjustable partial heating load in kW Auto: Product automatically adjusts max. partial load to current system demand	Auto	
D.001	Overrun time of internal heating pump for heating mode	2 to 60 min	5 min	
D.002	Max. burner anti-cycling time heating at 20 °C flow temperature	2 to 60 min	20 min	
D.005	Flow temperature target value (or return target value)	In °C, max. of the value set in D.071, limited by an eBUS control if connected		Not adjustable
D.006	Domestic hot water temperature target value	35 to 65 °C		Not adjustable
D.007	Warm start temperature target value	40 to 65 °C Frost protection is at 15 °C, then 40 to 70 °C (max. temperature can be adjusted under D.020)		Not adjustable
D.010	Heating pump status of the pump group	0 = Off 1 = On		Not adjustable
D.011	Status of external heating pump	0 = Off 1-100 = On		Not adjustable
D.014	Pump speed target value (high-efficiency pump)	Heating circuit pump target value in % 0 = Auto 1 = 53 2 = 60 3 = 70 4 = 85 5 = 100	4 = 85	
D.016	24 V DC room thermostat open/closed	0 = Room thermostat open (no heating mode) 1 = Room thermostat closed (heating mode)		Not adjustable
D.017	Heating flow/return temperature control changeover	Control type: 0 = Flow, 1 = Return	0 = Flow	
D.018	Pump mode setting	1 = Comfort (continuously operating pump) 3 = Eco (intermittently operating pump)	1 = Comfort	
D.022	Domestic hot water requirement via C1/C2, internal domestic hot water control system	0 = Off 1 = On		Not adjustable
D.023	Summer/winter mode (heating off/on)	0 = Heating off (Summer mode) 1 = Heating on		Not adjustable
D.025	Hot water generation enabled by eBUS control	0 = Off 1 = On		Not adjustable
D.026	Additional relay actuation	1 = Circulation pump 2 = External pump 3 = Cylinder charging pump 4 = Extraction hood 5 = External solenoid valve 6 = External fault message 7 = Solar pump (not active) 8 = eBUS remote control (not active) 9 = Anti-legionella pump (not active) 10 = Solar valve (not active)	2 = External pump	

Appendix

Code	Parameter	Values or explanations	Default setting	Own setting
D.027	Switching of relay 1 on the VR 40 "2 in 7" multi-functional module	1 = Circulation pump 2 = External pump 3 = Cylinder charging pump 4 = Extraction hood 5 = External solenoid valve 6 = External fault message 7 = Solar pump (not active) 8 = eBUS remote control (not active) 9 = Anti-legionella pump (not active) 10 = Solar valve (not active)	1 = Circulation pump	
D.028	Switching of relay 2 on the VR 40 "2 in 7" multi-functional module	1 = Circulation pump 2 = External pump 3 = Cylinder charging pump 4 = Extraction hood 5 = External solenoid valve 6 = External fault message 7 = Solar pump (not active) 8 = eBUS remote control (not active) 9 = Anti-legionella pump (not active) 10 = Solar valve (not active)	2 = External pump	
D.033	Fan speed target value	In rpm		Not adjustable
D.034	Fan speed actual value	In rpm		Not adjustable
D.039	Solar feed temperature	Actual value in °C		Not adjustable
D.040	Flow temperature	Actual value in °C		Not adjustable
D.041	Return temperature	Actual value in °C		Not adjustable
D.044	Digitised ionisation value	Display field 0 to 1020 > 800 no flame < 400 good flame		Not adjustable
D.046	Pump type	0 = Relay with disable facility 1 = PWM with disable facility	0 = Relay with disable facility	
D.047	Outdoor temperature (with Vaillant weather-compensated control)	Actual value in °C		Not adjustable
D.050	Offset for minimum speed	In rpm, adjustment range: 0 to 3000	Nominal value set in factory	
D.051	Offset for maximum speed	In rpm, adjustment range: -990 to 0	Nominal value set in factory	
D.060	Number of temperature cut-out shutdowns	Number of shutdowns		Not adjustable
D.061	Number of flame sequence control faults	Number of unsuccessful ignitions in the last attempt		Not adjustable
D.064	Average ignition time	In seconds		Not adjustable
D.065	Maximum ignition time	In seconds		Not adjustable
D.067	Remaining burner anti-cycling time	In minutes		Not adjustable
D.068	Unsuccessful ignitions at 1st attempt	Number of unsuccessful ignitions		Not adjustable
D.069	Unsuccessful ignitions at 2nd attempt	Number of unsuccessful ignitions		Not adjustable
D.071	Target value maximum heating flow temperature	40 to 85 °C	75 °C	

Code	Parameter	Values or explanations	Default setting	Own setting
D.072	Internal pump overrun time after cylinder charging	Adjustable from 0 to 10 mins	2 min	
D.076	Device specific number	82 = VU 806 81 = VU 1006 80 = VU 1206		Not adjustable
D.077	Limit on cylinder charging output in kW	Adjustable cylinder charging output in kW		
D.080	Operating hours, heating	In hours (h)		Not adjustable
D.081	Operating hours, hot water generation	In hours (h)		Not adjustable
D.082	Number of burner start-ups in heating mode	Number of burner start-ups		Not adjustable
D.083	Number of burner starts in domestic hot water mode	Number of burner start-ups		Not adjustable
D.084	Maintenance indicator: Number of hours until the next maintenance	Adjustment range: 0 to 3000 hrs and "---" for deactivated	,"---"	
D.090	Status of digital control	Recognised, not recognised		Not adjustable
D.091	Status of DCF with outdoor temperature sensor connected	No reception Reception Synchronised Valid		Not adjustable
D.093	Unit variant setting (DSN)	Adjustment range: 0 to 99		
D.094	Delete fault history	Delete fault list 0 = No 1 = Yes		
D.095	Software version of the eBUS components	1. PCB (BMU) 2. Display (AI) 4. HBI/VR34		Not adjustable
D.096	Default setting	Reset all adjustable parameters to factory setting 0 = No 1 = Yes		

C Inspection and maintenance work – Overview



Note

The table below lists the manufacturer requirements with respect to minimum inspection and maintenance intervals. If national regulations and directives require shorter inspection and maintenance intervals, you should observe these instead of the intervals listed in the table.

No.	Work	Inspection (annual)	Maintenance (At least every two years)
1	Check the air/flue pipe for leak-tightness and correct fastening. Make sure that it is not blocked or damaged and has been installed in accordance with the relevant set-up instructions.	X	X
2	Check the general condition of the product. Remove dirt from the product and from the vacuum chamber.	X	X
3	Visually inspect the general condition of the entire heating cell and, in particular, check for signs of corrosion, soot or other damage. If you notice any damage, carry out maintenance work.	X	X
4	Check the gas connection pressure at maximum heat input. If the gas connection pressure is not within the correct range, carry out maintenance work.	X	X
5	Check the CO ₂ content (air ratio) of the product and, if necessary, adjust it. Keep a record of this.	X	X
6	Disconnect the product from the power supply. Check that the electrical plug connections and other connections are seated correctly and correct these if necessary.	X	X
7	Close the gas stopcock and the service valves.		X

Appendix

No.	Work	Inspection (annual)	Maintenance (At least every two years)
8	Check, and if necessary correct, the pre-charge pressure of the expansion vessel.		X
9	Remove the gas-air mixture unit (burner door with fan and gas valve assembly).		X
10	Check all seals and the insulating mat in the combustion area. If you notice any damage, replace the seals or insulating mat. Replace the burner door seal after each time it is opened and, accordingly, each time maintenance work is carried out.		X
11	Clean the heat exchanger.		X
12	Check the burner for damage and replace it if necessary.		X
13	Check the condensate trap on the product, clean and fill if necessary.	X	X
14	Reinstall the gas-air mixture unit. Caution: Replace the seals.		X
15	Replace the ignition and monitoring electrodes and the associated seals.		X
16	Motorised flue non-return flaps for cascade operation: Check that the flue non-return flap functions faultlessly. If required, clean the inside and outside of the housing, as well as the shut-off disc and the shaft.		X
17	Check that the product is leak-tight.	X	X
18	Open the gas stopcock, reconnect the product to the power grid and switch the product on.	X	X
19	Open the service valves, fill up the product/heating installation to 1.0-4.5 bar (depending on the static height of the heating installation) and start the purging programme P.00 .		X
20	Perform a test operation of the product and heating installation, including hot water generation, and purge the system once more if necessary.	X	X
21	Visually inspect the ignition and burner behaviour.	X	X
22	Check the CO ₂ content (the air ratio) of the product again.		X
23	Check the product for gas, flue gas, hot water and condensate leaks, and repair if necessary.	X	X
24	Record the inspection/maintenance work carried out.	X	X
25	Check the quality of the heating water (hardness level) and log the values in a system book. If required, use water treatment to correct the water hardness.	X	X

D Status codes – Overview

Status code	Meaning
Heating mode	
S.00	Heating: No heat demand
S.01	Heating mode: Fan start-up
S.02	Heating mode: Pump prerun
S.03	Heating mode: Ignition
S.04	Heating mode: Burner on
S.05	Heating mode: Pump/fan overrun
S.06	Heating mode: Fan overrun
S.07	Heating mode: Pump overrun
S.08	Heating mode: Remaining anti-cycling time
S.09	Heating mode: Measuring programme
S.20	Domestic hot water requirement
S.21	DHW mode: Fan start-up
S.22	DHW mode: Pump prerun
S.23	DHW mode: Ignition
S.24	DHW mode: Burner on
S.25	DHW mode: Pump/fan overrun
S.26	DHW mode: Fan overrun
S.27	Domestic hot water mode: Pump overrun
S.28	DHW mode: Burner anti-cycling time

Status code	Meaning
Special cases	
S.30	Room thermostat (RT) is blocking heating mode
S.31	Summer mode active or no heat requirement from eBUS control
S.32	Waiting period because of fan speed deviation
S.34	Frost protection mode active
S.36	Target value of the eBUS control is < 20 °C and is blocking heating mode
S.37	Fan waiting period: Fan failure in operation
S.39	"Burner off contact" has triggered (e.g. surface-mounted thermostat or condensate pump)
S.40	Comfort protection mode is active: Product running with limited heating comfort
S.41	Water pressure > 0.6 MPa (6 bar)
S.42	Flue non-return flap response blocks burner operation (only in conjunction with accessory VR40) or condensate pump defective; heat requirement is blocked
S.44	"Return temperature sensor" comfort protection mode is active; product running with limited heating comfort
S.46	"Flame lost at min. output" comfort protection mode is active; product running with limited heating comfort
S.47	"Flame lost at max. output" comfort protection mode is active; product running with limited heating comfort
S.48	"Deviating fan speed" comfort protection mode is active; product running with limited heating comfort
S.53	Product is within the waiting period of the modulation block/operating block function as a result of water deficiency (flow/return spread too large)
S.54	Product is within the waiting period of the operating blocking function as a result of water deficiency (temperature gradient)
S.96	Return sensor test running, heating demands are blocked.
S.97	Water pressure sensor test running, heating demands are blocked.
S.98	Flow/return sensor test running, heating demands are blocked.

E Overview of fault codes

Code	Meaning	Cause
F.00	Flow temperature sensor interruption	NTC plug not plugged in or has come loose, multiple plug on the PCB not plugged in correctly, interruption in cable harness, NTC defective
F.01	Return temperature sensor interruption	NTC plug not plugged in or has come loose, multiple plug on the PCB not plugged in correctly, interruption in cable harness, NTC defective
F.10	Flow temperature sensor short circuit	NTC defective, short circuit in cable harness, cable/housing
F.11	Return temperature sensor short circuit	NTC defective, short circuit in cable harness, cable/housing
F.20	Safety shutdown: Temperature cut-out	Incorrect earth connection between cable harness and product, flow or return NTC defective (loose connection), stray spark via ignition cable, ignition plug or ignition electrode, flue gas temperature too high
F.22	Safety shutdown: Water deficiency	No or insufficient water in the product, water pressure sensor defective, cable to pump or water pressure sensor loose/not connected/defective
F.23	Safety shutdown: Temperature spread too great	Pump blocked, insufficient pump output, air in product, flow and return NTC connected the wrong way round
F.24	Safety shutdown: Temperature rise too fast	Pump blocked, insufficient pump output, air in product, system pressure too low, non-return valve blocked/incorrectly installed
F.25	Safety shutdown: Flue gas temperature too high	Break in plug connection for optional flue gas safety cut-out (SCO), break in cable harness
F.27	Safety shutdown: Flame simulation	Moisture on the electronics, electronics (flame monitor) defective, gas solenoid valve leaking
F.28	Failure during start-up: Ignition unsuccessful	Gas meter defective or gas pressure switch has triggered, air in gas, gas flow pressure too low, thermal cut-out has triggered, condensate route blocked, incorrect gas injector, incorrect spare gas valve assembly, fault on the gas valve assembly, multiple plug on PCB incorrectly plugged in, break in cable harness, ignition system (ignition transformer, ignition cable, ignition plug, ignition electrode) defective, ionisation flow interrupted (cable, electrode), incorrect earthing of product, electronics defective
F.29	Failure during operation: Re-ignition unsuccessful	Gas supply temporarily stopped, flue gas recirculation, condensate route blocked, defective earthing of product, ignition transformer has spark failure

Appendix

Code	Meaning	Cause
F.32	Fan fault	Plug on fan not correctly plugged in, multiple plug on PCB not correctly plugged in, break in cable harness, fan blocked, Hall sensor defective, electronics defective
F.34	Safety shutdown: Pressure monitoring	Flue pressure switch: Cable break, blocked flue gas route Water pressure switch: Hydraulic leakage, air in the heating circuit
F.35	Fault: Air/flue pipe	Air/flue pipe blocked
F.49	Fault: eBUS	Short circuit on eBUS, eBUS overload or two power supplies with different polarities on the eBUS
F.61	Fault: Gas valve assembly actuation	<ul style="list-style-type: none"> - Short circuit/short to earth in cable harness for the gas valve assembly - Gas valve assembly defective (coils shorted to earth) - Electronics defective
F.62	Fault: Gas valve assembly switch-off delay	<ul style="list-style-type: none"> - Delayed shutdown of gas valve assembly - Delayed extinguishing of flame signal - Gas valve assembly leaking - Electronics defective
F.63	Fault: EEPROM	Electronics defective
F.64	Fault: Electronics/NTC	Flow or return NTC short circuited, electronics defective
F.65	Fault: Electronics temp.	Electronics overheating due to external influences, electronics defective
F.67	Fault: Electronics/flame	Implausible flame signal, electronics defective
F.68	Fault: Unstable flame signal	Air in gas, gas flow pressure too low, incorrect air ratio, condensate route blocked, incorrect gas injector, ionisation flow interruption (cable, electrode), flue gas recirculation, condensate route
F.70	Invalid device specific number (DSN)	If spare parts were integrated: Display and PCB replaced at the same time and Device Specific Number not reset; incorrect cable harness; liquefied petroleum gas coding resistor and DSN do not match
F.73	Water pressure sensor signal in the wrong range (too low)	Interruption/short circuit of water pressure sensor, interruption/short circuit to GND in supply line to water pressure sensor or water pressure sensor defective
F.74	Water pressure sensor signal outside correct range (too high)	Line to water pressure sensor has a short circuit to 5 V/24 V or internal fault in the water pressure sensor
F.75	Fault: No pressure change detection when starting pump	Water pressure sensor and/or pump defective, air in the heating installation, insufficient water in the product; check adjustable bypass, connect external expansion vessel to the return
F.76	Overheating protection on primary heat exchanger has responded	Cable or cable connections for safety fuse in primary heat exchanger or primary heat exchanger defective
F.77	Fault: Flue non-return flap/condensate pump	No response from flue non-return flap or condensate pump defective
Communication fault	No communication with the PCB	Communication fault between display and PCB in the electronics box
F.83	Fault: Flow and/or return temperature sensor temperature change	<p>When the burner starts, the temperature change registered at the flow and/or return temperature sensor is non-existent or too small</p> <ul style="list-style-type: none"> - Insufficient water in product - Flow/return temperature sensor not installed correctly
F.84	Fault: Flow/return temperature sensor temperature difference implausible	<p>Flow/return temperature sensors returning implausible values</p> <ul style="list-style-type: none"> - Flow/return temperature sensor not installed correctly

F Wiring diagram

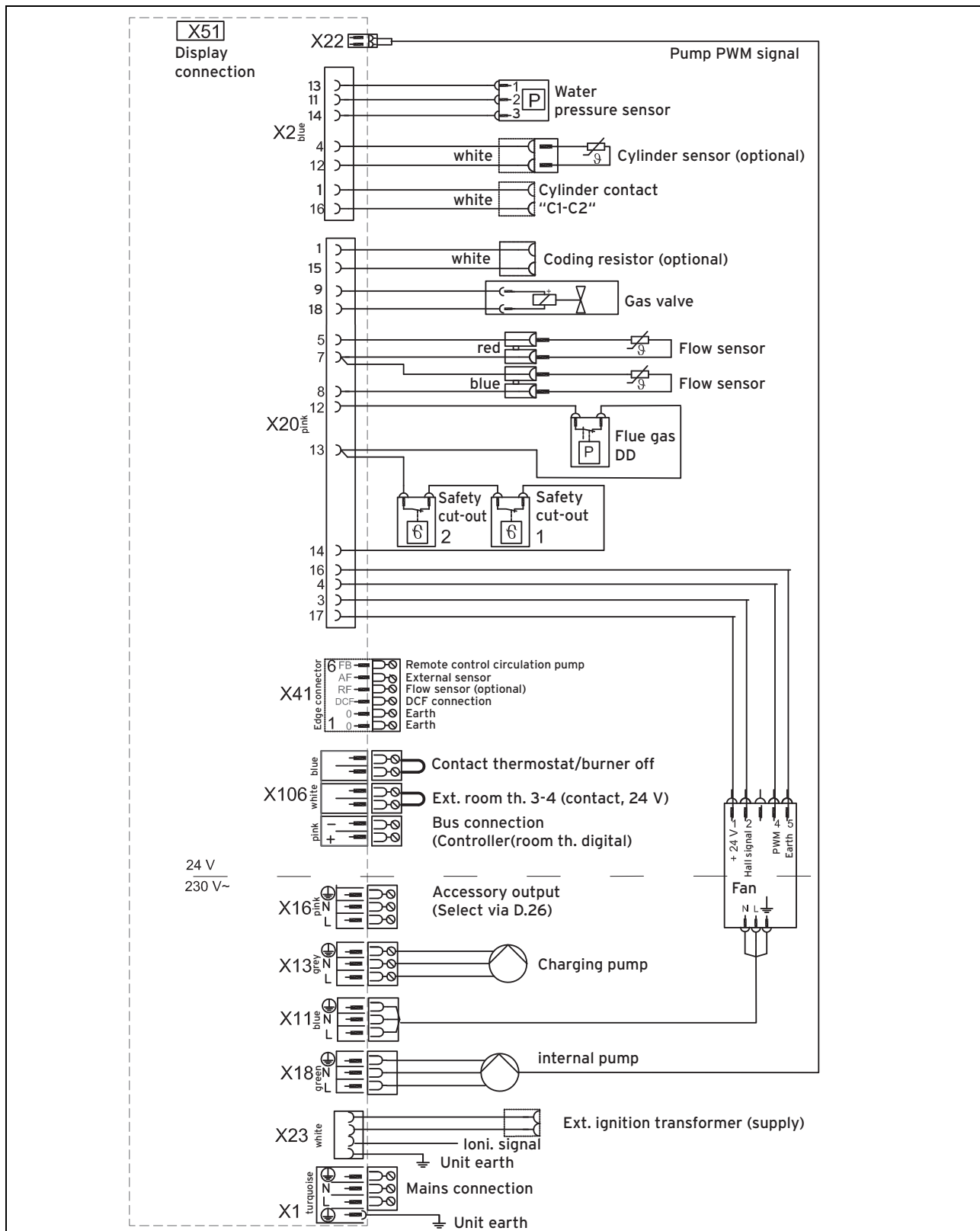

Appendix

G Initial start-up checklist

	Location	Competent person	Customer service technician
Name			
Street/house number			
Postcode			
Town/city			
Telephone			
Start-up date			
Serial number			
Basic hydraulic diagram			

G.1 Initial start-up checklist

	Yes	No	Values	Unit
Installation, general				
Building type (house/apartment building, special building)				
Used for commercial purposes?				
Year of manufacture				
Insulation status/renovation				
System output				kW
Previous gas/energy consumption				m ³ or kWh/a
Heated surface				m ²
Number of heating circuits				
– Underfloor heating circuits				
– Radiator heating circuits				
– Ventilator heating circuits				
Water hardness when starting up				mol/m ³ or mg/l CaCO ₃
Type of cleaning carried out?				
First flushing (cold) of the heating circuit carried out?				
First flushing (cold) of the boiler carried out?				
Which chemicals used for cleaning?				
Which treatment of hot flush filling water?				
Second flushing (hot) of the boiler carried out?				
Maintenance schedule for checking levels of inhibitor?				
System volume				l
Added additive: Designation, amount				
Gas supply				
Gas type				
Net calorific value				kWh/m ³
Gas pressure regulator available? If yes, which type?				
Condensate discharge				
Condensate trap filled?				
Condensate discharge pipe routed with a downward gradient?				
Neutralisation device available (> 200 kW)? If yes, which manufacturer?				
Condensate pump available (if required)?				
Condensate pump control line connected?				
Hydraulics				

	Yes	No	Values	Unit
Heating circuit system pressure				MPa (bar)
Piping at least 1.5 inches (single unit)				
Piping at least DN65 (cascade up to 360 kW)				
Piping at least DN100 (cascade > 360 kW)				
Expansion relief valve				MPa (bar)
System separation using a plate heat exchanger Which type?				
Number of mixers				
Cylinder				l
– Buffer cylinder (if yes, which type?)				
– Domestic hot water cylinder (if yes, which type?)				
Pumps				
– Secondary circuit (if yes, which type?)				
– Heating circuits (if yes, which type?)				
Number of diaphragm expansion vessels				l
– Primary circuit				
– Secondary circuit				
– Heating circuits				
Plate heat exchanger installed correctly?				
System sensor installed correctly?				
Heating circuits sufficiently purged?				
When installing a pump without a pump assembly				
Pressure loss between the pump and the unit < 2 kPa (20 mbar) at 4 m ³ /h (required)				
Distance between the pump and product is less than 0.5 m (required)				
Pump in the return (required)				
When using a third-party pump				
Pump connected to BMU (signal and voltage) (required)				
Pump curve at least in accordance with the instructions (required)				
Domestic hot water supply				
Energy source (gas or electricity?)				
Via unit circuit				
Via heating circuit				
Charging pump available? If yes, which type?				
At a cylinder size of < 200 l, the cylinder charging output is limited to 30 kW (D.070)?				
Flue system				
Installation type (open-flued/room-sealed)				
For open-flued installation: Large supply air opening				cm ²
Element of the air/flue pipe up to the hearth:				m or mm
– Length				
– Diameter				
Number of elbows fitted				
Hearth				m or mm
– Material				
– Height				
– Diameter				
Cascade				
Hydr. non-return flaps in the flow line?				

Appendix

	Yes	No	Values	Unit
Motorised flue non-return flaps wired correctly?				
D.027/D.028 (switching of relay 2) to 4 (= extraction hood) set?				
D.090 (eBus control) detected?				
Condensate delivery pump (if required): Fault message cable connected to each product?				
Other heat generators				
Solar system, heat pump, solid fuel boiler? If yes, which type?				
Control system				
Vaillant control If yes, which type?				
Third-party control If yes, which type?				
Room temperature control, outdoor temperature control If yes, which type?				
Heating demand from which control?				
Domestic hot water demand from control (internal/external)				
Sensor positioned correctly and connected?				
vmetDIALOG installed correctly, signal available?				
Start-up/default settings				
CO ₂ content at max. via P.1 (before adjustment)				Vol. %
CO ₂ content at max. via P.1 (after adjustment)				Vol. %
Gas flow pressure at nominal heat loading (max. output for cascades)				kPa (mbar)
CO ₂ content at min. via P.2				Vol. %
Gas volume flow at P _{max} via P.1 (if possible)				m ³ /min
Gas volume flow at P _{min} via P.2 (if possible)				m ³ /min
Primary circuit water sample				mol/m ³ or mg/l CaCO ₃
Secondary circuit water sample				mol/m ³ or mg/l CaCO ₃
Heating circuit system pressure				MPa (bar)
Default settings				
Partial heating load via D.000				kW
Pump overrun via D.001				min
Max. burner anti-cycling time via D.002				min
Max. cylinder charging output via D.077				kW

H Commissioning Checklist

Benchmark Commissioning and Servicing Section

It is a requirement that the boiler is installed and commissioned to the manufacturers instructions and the data fields on the commissioning checklist completed in full.

To instigate the boiler guarantee the boiler needs to be registered with the manufacturer within one month of the installation.

To maintain the boiler guarantee it is essential that the boiler is serviced annually by a Gas Safe registered engineer who has been trained on the boiler installed. The service details should be recorded on the Benchmark Service Interval Record and left with the householder.



www.centralheating.co.uk

GAS BOILER SYSTEM COMMISSIONING CHECKLIST

This Commissioning Checklist is to be completed in full by the competent person who commissioned the boiler as a means of demonstrating compliance with the appropriate Building Regulations and then handed to the customer to keep for future reference.

Failure to install and commission according to the manufacturer's instructions and complete this Benchmark Commissioning Checklist will invalidate the warranty. This does not affect the customer's statutory rights.

Customer name:				Telephone number:				
Address:								
Boiler make and model:								
Boiler serial number:								
Commissioned by (PRINT NAME):				Gas Safe register number:				
Company name:				Telephone number:				
Company address:								
Commissioning date:								
To be completed by the customer on receipt of a Building Regulations Compliance Certificate*								
Building Regulations Notification Number (if applicable):								
CONTROLS (tick the appropriate boxes)								
Time and temperature control to heating	Room thermostat and programmer/timer		Programmable room thermostat					
	Load/weather compensation		Optimum start control					
Time and temperature control to hot water	Cylinder thermostat and programmer/timer		Combination Boiler					
Heating zone valves	Fitted		Not required					
Hot water zone valves	Fitted		Not required					
Thermostatic radiator valves	Fitted		Not required					
Automatic bypass to system	Fitted		Not required					
Boiler interlock			Provided					
ALL SYSTEMS								
The system has been flushed and cleaned in accordance with BS7593 and boiler manufacturer's instructions							Yes	
What system cleaner was used?								
What inhibitor was used?							Quantity	litres
Has a primary water system filter been installed?							Yes	No
CENTRAL HEATING MODE measure and record:								
Gas rate	m ³ /hr		OR		ft ³ /hr			
Burner operating pressure (if applicable)	mbar		OR Gas inlet pressure		mbar			
Central heating flow temperature					°C			
Central heating return temperature					°C			
COMBINATION BOILERS ONLY								
Is the installation in a hard water area (above 200ppm)?							Yes	No
If yes, and if required by the manufacturer, has a water scale reducer been fitted?							Yes	No
What type of scale reducer has been fitted?								
DOMESTIC HOT WATER MODE Measure and Record:								
Gas rate	m ³ /hr		OR		ft ³ /hr			
Burner operating pressure (at maximum rate)	mbar		OR Gas inlet pressure at maximum rate		mbar			
Cold water inlet temperature					°C			
Hot water has been checked at all outlets							Yes	Temperature °C
Water flow rate					l/min			
CONDENSING BOILERS ONLY								
The condensate drain has been installed in accordance with the manufacturer's instructions and/or BS5546/BS6798							Yes	
ALL INSTALLATIONS								
Record the following:	At max. rate:	CO	ppm	AND	CO/CO ₂	Ratio		
	At min. rate: (where possible)	CO	ppm	AND	CO/CO ₂	Ratio		
The heating and hot water system complies with the appropriate Building Regulations							Yes	
The boiler and associated products have been installed and commissioned in accordance with the manufacturer's instructions							Yes	
The operation of the boiler and system controls have been demonstrated to and understood by the customer							Yes	
The manufacturer's literature, including Benchmark Checklist and Service Record, has been explained and left with the customer							Yes	
Commissioning Engineer's Signature								
Customer's Signature								
(To confirm satisfactory demonstration and receipt of manufacturer's literature)								

*All installations in England and Wales must be notified to Local Authority Building Control (LABC) either directly or through a Competent Persons Scheme. A Building Regulations Compliance Certificate will then be issued to the customer.



SERVICE RECORD

It is recommended that your heating system is serviced regularly and that the appropriate Service Interval Record is completed.

Service Provider

Before completing the appropriate Service Record below, please ensure you have carried out the service as described in the manufacturer's instructions. Always use the manufacturer's specified spare part when replacing controls.

<table border="1" style="width:100%; border-collapse: collapse;"> <tr> <td colspan="5">SERVICE 01</td> <td>Date:</td> </tr> <tr> <td colspan="6">Engineer name:</td> </tr> <tr> <td colspan="6">Company name:</td> </tr> <tr> <td colspan="6">Telephone No:</td> </tr> <tr> <td colspan="6">Gas safe register No:</td> </tr> <tr> <td>Record:</td> <td>At max. rate:</td> <td>CO</td> <td>ppm</td> <td>AND</td> <td>CO₂ %</td> </tr> <tr> <td></td> <td>At min. rate: (Where Possible)</td> <td>CO</td> <td>ppm</td> <td>AND</td> <td>CO₂ %</td> </tr> <tr> <td colspan="6">Comments:</td> </tr> <tr> <td colspan="6">Signature</td> </tr> </table>	SERVICE 01					Date:	Engineer name:						Company name:						Telephone No:						Gas safe register No:						Record:	At max. rate:	CO	ppm	AND	CO ₂ %		At min. rate: (Where Possible)	CO	ppm	AND	CO ₂ %	Comments:						Signature						<table border="1" style="width:100%; border-collapse: collapse;"> <tr> <td colspan="5">SERVICE 02</td> <td>Date:</td> </tr> <tr> <td colspan="6">Engineer name:</td> </tr> <tr> <td colspan="6">Company name:</td> </tr> <tr> <td colspan="6">Telephone No:</td> </tr> <tr> <td colspan="6">Gas safe register No:</td> </tr> <tr> <td>Record:</td> <td>At max. rate:</td> <td>CO</td> <td>ppm</td> <td>AND</td> <td>CO₂ %</td> </tr> <tr> <td></td> <td>At min. rate: (Where Possible)</td> <td>CO</td> <td>ppm</td> <td>AND</td> <td>CO₂ %</td> </tr> <tr> <td colspan="6">Comments:</td> </tr> <tr> <td colspan="6">Signature</td> </tr> </table>	SERVICE 02					Date:	Engineer name:						Company name:						Telephone No:						Gas safe register No:						Record:	At max. rate:	CO	ppm	AND	CO ₂ %		At min. rate: (Where Possible)	CO	ppm	AND	CO ₂ %	Comments:						Signature					
SERVICE 01					Date:																																																																																																								
Engineer name:																																																																																																													
Company name:																																																																																																													
Telephone No:																																																																																																													
Gas safe register No:																																																																																																													
Record:	At max. rate:	CO	ppm	AND	CO ₂ %																																																																																																								
	At min. rate: (Where Possible)	CO	ppm	AND	CO ₂ %																																																																																																								
Comments:																																																																																																													
Signature																																																																																																													
SERVICE 02					Date:																																																																																																								
Engineer name:																																																																																																													
Company name:																																																																																																													
Telephone No:																																																																																																													
Gas safe register No:																																																																																																													
Record:	At max. rate:	CO	ppm	AND	CO ₂ %																																																																																																								
	At min. rate: (Where Possible)	CO	ppm	AND	CO ₂ %																																																																																																								
Comments:																																																																																																													
Signature																																																																																																													
<table border="1" style="width:100%; border-collapse: collapse;"> <tr> <td colspan="5">SERVICE 03</td> <td>Date:</td> </tr> <tr> <td colspan="6">Engineer name:</td> </tr> <tr> <td colspan="6">Company name:</td> </tr> <tr> <td colspan="6">Telephone No:</td> </tr> <tr> <td colspan="6">Gas safe register No:</td> </tr> <tr> <td>Record:</td> <td>At max. rate:</td> <td>CO</td> <td>ppm</td> <td>AND</td> <td>CO₂ %</td> </tr> <tr> <td></td> <td>At min. rate: (Where Possible)</td> <td>CO</td> <td>ppm</td> <td>AND</td> <td>CO₂ %</td> </tr> <tr> <td colspan="6">Comments:</td> </tr> <tr> <td colspan="6">Signature</td> </tr> </table>	SERVICE 03					Date:	Engineer name:						Company name:						Telephone No:						Gas safe register No:						Record:	At max. rate:	CO	ppm	AND	CO ₂ %		At min. rate: (Where Possible)	CO	ppm	AND	CO ₂ %	Comments:						Signature						<table border="1" style="width:100%; border-collapse: collapse;"> <tr> <td colspan="5">SERVICE 04</td> <td>Date:</td> </tr> <tr> <td colspan="6">Engineer name:</td> </tr> <tr> <td colspan="6">Company name:</td> </tr> <tr> <td colspan="6">Telephone No:</td> </tr> <tr> <td colspan="6">Gas safe register No:</td> </tr> <tr> <td>Record:</td> <td>At max. rate:</td> <td>CO</td> <td>ppm</td> <td>AND</td> <td>CO₂ %</td> </tr> <tr> <td></td> <td>At min. rate: (Where Possible)</td> <td>CO</td> <td>ppm</td> <td>AND</td> <td>CO₂ %</td> </tr> <tr> <td colspan="6">Comments:</td> </tr> <tr> <td colspan="6">Signature</td> </tr> </table>	SERVICE 04					Date:	Engineer name:						Company name:						Telephone No:						Gas safe register No:						Record:	At max. rate:	CO	ppm	AND	CO ₂ %		At min. rate: (Where Possible)	CO	ppm	AND	CO ₂ %	Comments:						Signature					
SERVICE 03					Date:																																																																																																								
Engineer name:																																																																																																													
Company name:																																																																																																													
Telephone No:																																																																																																													
Gas safe register No:																																																																																																													
Record:	At max. rate:	CO	ppm	AND	CO ₂ %																																																																																																								
	At min. rate: (Where Possible)	CO	ppm	AND	CO ₂ %																																																																																																								
Comments:																																																																																																													
Signature																																																																																																													
SERVICE 04					Date:																																																																																																								
Engineer name:																																																																																																													
Company name:																																																																																																													
Telephone No:																																																																																																													
Gas safe register No:																																																																																																													
Record:	At max. rate:	CO	ppm	AND	CO ₂ %																																																																																																								
	At min. rate: (Where Possible)	CO	ppm	AND	CO ₂ %																																																																																																								
Comments:																																																																																																													
Signature																																																																																																													
<table border="1" style="width:100%; border-collapse: collapse;"> <tr> <td colspan="5">SERVICE 05</td> <td>Date:</td> </tr> <tr> <td colspan="6">Engineer name:</td> </tr> <tr> <td colspan="6">Company name:</td> </tr> <tr> <td colspan="6">Telephone No:</td> </tr> <tr> <td colspan="6">Gas safe register No:</td> </tr> <tr> <td>Record:</td> <td>At max. rate:</td> <td>CO</td> <td>ppm</td> <td>AND</td> <td>CO₂ %</td> </tr> <tr> <td></td> <td>At min. rate: (Where Possible)</td> <td>CO</td> <td>ppm</td> <td>AND</td> <td>CO₂ %</td> </tr> <tr> <td colspan="6">Comments:</td> </tr> <tr> <td colspan="6">Signature</td> </tr> </table>	SERVICE 05					Date:	Engineer name:						Company name:						Telephone No:						Gas safe register No:						Record:	At max. rate:	CO	ppm	AND	CO ₂ %		At min. rate: (Where Possible)	CO	ppm	AND	CO ₂ %	Comments:						Signature						<table border="1" style="width:100%; border-collapse: collapse;"> <tr> <td colspan="5">SERVICE 06</td> <td>Date:</td> </tr> <tr> <td colspan="6">Engineer name:</td> </tr> <tr> <td colspan="6">Company name:</td> </tr> <tr> <td colspan="6">Telephone No:</td> </tr> <tr> <td colspan="6">Gas safe register No:</td> </tr> <tr> <td>Record:</td> <td>At max. rate:</td> <td>CO</td> <td>ppm</td> <td>AND</td> <td>CO₂ %</td> </tr> <tr> <td></td> <td>At min. rate: (Where Possible)</td> <td>CO</td> <td>ppm</td> <td>AND</td> <td>CO₂ %</td> </tr> <tr> <td colspan="6">Comments:</td> </tr> <tr> <td colspan="6">Signature</td> </tr> </table>	SERVICE 06					Date:	Engineer name:						Company name:						Telephone No:						Gas safe register No:						Record:	At max. rate:	CO	ppm	AND	CO ₂ %		At min. rate: (Where Possible)	CO	ppm	AND	CO ₂ %	Comments:						Signature					
SERVICE 05					Date:																																																																																																								
Engineer name:																																																																																																													
Company name:																																																																																																													
Telephone No:																																																																																																													
Gas safe register No:																																																																																																													
Record:	At max. rate:	CO	ppm	AND	CO ₂ %																																																																																																								
	At min. rate: (Where Possible)	CO	ppm	AND	CO ₂ %																																																																																																								
Comments:																																																																																																													
Signature																																																																																																													
SERVICE 06					Date:																																																																																																								
Engineer name:																																																																																																													
Company name:																																																																																																													
Telephone No:																																																																																																													
Gas safe register No:																																																																																																													
Record:	At max. rate:	CO	ppm	AND	CO ₂ %																																																																																																								
	At min. rate: (Where Possible)	CO	ppm	AND	CO ₂ %																																																																																																								
Comments:																																																																																																													
Signature																																																																																																													
<table border="1" style="width:100%; border-collapse: collapse;"> <tr> <td colspan="5">SERVICE 07</td> <td>Date:</td> </tr> <tr> <td colspan="6">Engineer name:</td> </tr> <tr> <td colspan="6">Company name:</td> </tr> <tr> <td colspan="6">Telephone No:</td> </tr> <tr> <td colspan="6">Gas safe register No:</td> </tr> <tr> <td>Record:</td> <td>At max. rate:</td> <td>CO</td> <td>ppm</td> <td>AND</td> <td>CO₂ %</td> </tr> <tr> <td></td> <td>At min. rate: (Where Possible)</td> <td>CO</td> <td>ppm</td> <td>AND</td> <td>CO₂ %</td> </tr> <tr> <td colspan="6">Comments:</td> </tr> <tr> <td colspan="6">Signature</td> </tr> </table>	SERVICE 07					Date:	Engineer name:						Company name:						Telephone No:						Gas safe register No:						Record:	At max. rate:	CO	ppm	AND	CO ₂ %		At min. rate: (Where Possible)	CO	ppm	AND	CO ₂ %	Comments:						Signature						<table border="1" style="width:100%; border-collapse: collapse;"> <tr> <td colspan="5">SERVICE 08</td> <td>Date:</td> </tr> <tr> <td colspan="6">Engineer name:</td> </tr> <tr> <td colspan="6">Company name:</td> </tr> <tr> <td colspan="6">Telephone No:</td> </tr> <tr> <td colspan="6">Gas safe register No:</td> </tr> <tr> <td>Record:</td> <td>At max. rate:</td> <td>CO</td> <td>ppm</td> <td>AND</td> <td>CO₂ %</td> </tr> <tr> <td></td> <td>At min. rate: (Where Possible)</td> <td>CO</td> <td>ppm</td> <td>AND</td> <td>CO₂ %</td> </tr> <tr> <td colspan="6">Comments:</td> </tr> <tr> <td colspan="6">Signature</td> </tr> </table>	SERVICE 08					Date:	Engineer name:						Company name:						Telephone No:						Gas safe register No:						Record:	At max. rate:	CO	ppm	AND	CO ₂ %		At min. rate: (Where Possible)	CO	ppm	AND	CO ₂ %	Comments:						Signature					
SERVICE 07					Date:																																																																																																								
Engineer name:																																																																																																													
Company name:																																																																																																													
Telephone No:																																																																																																													
Gas safe register No:																																																																																																													
Record:	At max. rate:	CO	ppm	AND	CO ₂ %																																																																																																								
	At min. rate: (Where Possible)	CO	ppm	AND	CO ₂ %																																																																																																								
Comments:																																																																																																													
Signature																																																																																																													
SERVICE 08					Date:																																																																																																								
Engineer name:																																																																																																													
Company name:																																																																																																													
Telephone No:																																																																																																													
Gas safe register No:																																																																																																													
Record:	At max. rate:	CO	ppm	AND	CO ₂ %																																																																																																								
	At min. rate: (Where Possible)	CO	ppm	AND	CO ₂ %																																																																																																								
Comments:																																																																																																													
Signature																																																																																																													
<table border="1" style="width:100%; border-collapse: collapse;"> <tr> <td colspan="5">SERVICE 09</td> <td>Date:</td> </tr> <tr> <td colspan="6">Engineer name:</td> </tr> <tr> <td colspan="6">Company name:</td> </tr> <tr> <td colspan="6">Telephone No:</td> </tr> <tr> <td colspan="6">Gas safe register No:</td> </tr> <tr> <td>Record:</td> <td>At max. rate:</td> <td>CO</td> <td>ppm</td> <td>AND</td> <td>CO₂ %</td> </tr> <tr> <td></td> <td>At min. rate: (Where Possible)</td> <td>CO</td> <td>ppm</td> <td>AND</td> <td>CO₂ %</td> </tr> <tr> <td colspan="6">Comments:</td> </tr> <tr> <td colspan="6">Signature</td> </tr> </table>	SERVICE 09					Date:	Engineer name:						Company name:						Telephone No:						Gas safe register No:						Record:	At max. rate:	CO	ppm	AND	CO ₂ %		At min. rate: (Where Possible)	CO	ppm	AND	CO ₂ %	Comments:						Signature						<table border="1" style="width:100%; border-collapse: collapse;"> <tr> <td colspan="5">SERVICE 10</td> <td>Date:</td> </tr> <tr> <td colspan="6">Engineer name:</td> </tr> <tr> <td colspan="6">Company name:</td> </tr> <tr> <td colspan="6">Telephone No:</td> </tr> <tr> <td colspan="6">Gas safe register No:</td> </tr> <tr> <td>Record:</td> <td>At max. rate:</td> <td>CO</td> <td>ppm</td> <td>AND</td> <td>CO₂ %</td> </tr> <tr> <td></td> <td>At min. rate: (Where Possible)</td> <td>CO</td> <td>ppm</td> <td>AND</td> <td>CO₂ %</td> </tr> <tr> <td colspan="6">Comments:</td> </tr> <tr> <td colspan="6">Signature</td> </tr> </table>	SERVICE 10					Date:	Engineer name:						Company name:						Telephone No:						Gas safe register No:						Record:	At max. rate:	CO	ppm	AND	CO ₂ %		At min. rate: (Where Possible)	CO	ppm	AND	CO ₂ %	Comments:						Signature					
SERVICE 09					Date:																																																																																																								
Engineer name:																																																																																																													
Company name:																																																																																																													
Telephone No:																																																																																																													
Gas safe register No:																																																																																																													
Record:	At max. rate:	CO	ppm	AND	CO ₂ %																																																																																																								
	At min. rate: (Where Possible)	CO	ppm	AND	CO ₂ %																																																																																																								
Comments:																																																																																																													
Signature																																																																																																													
SERVICE 10					Date:																																																																																																								
Engineer name:																																																																																																													
Company name:																																																																																																													
Telephone No:																																																																																																													
Gas safe register No:																																																																																																													
Record:	At max. rate:	CO	ppm	AND	CO ₂ %																																																																																																								
	At min. rate: (Where Possible)	CO	ppm	AND	CO ₂ %																																																																																																								
Comments:																																																																																																													
Signature																																																																																																													

*All installations in England and Wales must be notified to Local Authority Building Control (LABC) either directly or through a Competent Persons Scheme. A Building Regulations Compliance Certificate will then be issued to the customer.



Appendix

I Position of the opening in the air/flue pipe

The diagram is relevant for the installation of boilers with a gross heat input > 70 kW net but less than 333 kW net. For further information see the current IGEM UP/10 and the risk assessment appendix for guidance on suitable flue terminal locations.

For installations above 333 kW net input, refer to the “Clean Air Act,” as the discharge of flue products must comply with the stated and calculated distances above ground (see note 3).

It is essential to ensure that discharged flue products do not create any hazard or nuisance to persons within the discharge area and do not come into contact with building surfaces or build-up within an area where they may re-enter a building.

I.1 Notes

1. No installations should discharge into a courtyard, light well, car port or enclosed environment.
2. Care should be taken to ensure that even if the installation complies with the minimum dimensions shown, that all site conditions are taken into consideration to avoid products re-entering the building, the plume becoming a nuisance or causing wall staining.
3. Above 333 kW net input the height and termination of flues will require approval from the local authority.

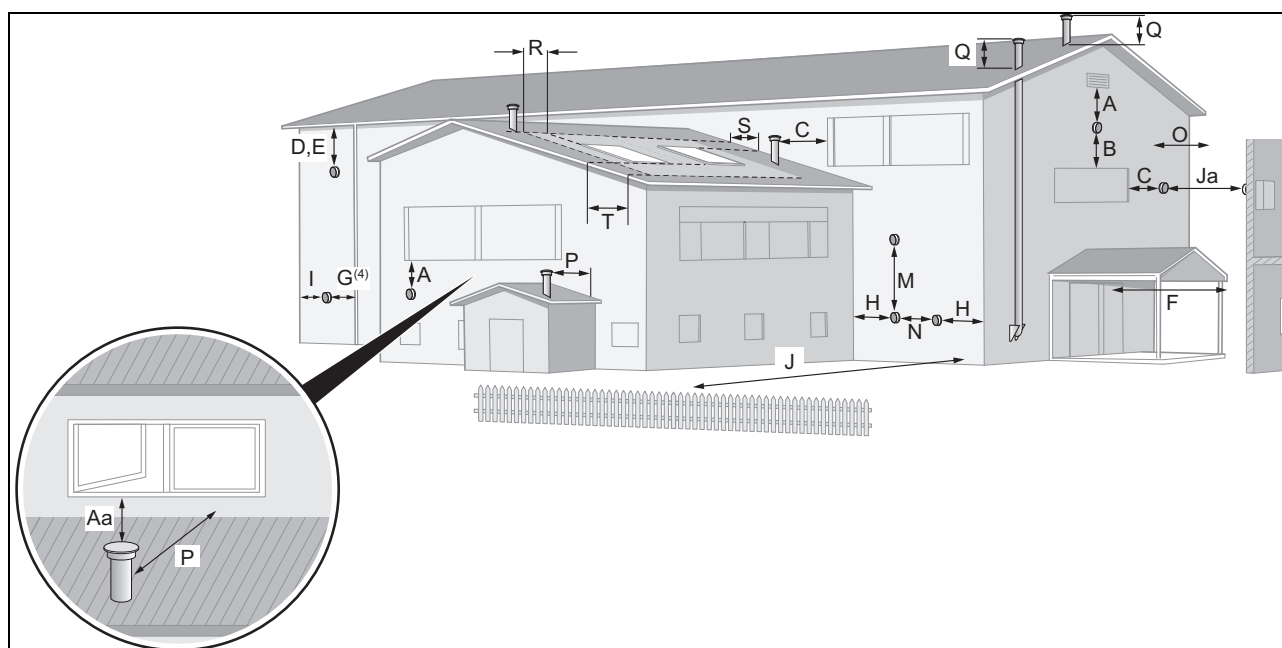

I.2 Positioning of the opening of a fan-supported flue system

Minimum clearances for concentric terminations			
Key	Horizontal → 70 kW up to 120 kW	mm	All systems > 120 kW
*Products must disperse freely and not make contact with building surfaces			
1.	There should be no ventilation/opening in the eaves within 900 mm of the terminal.		
2.	These dimensions comply with the building regulations, but they may need to be increased to avoid wall staining and nuisance from plumbing depending on site conditions.		
3.	It is recommended that an elbow termination is fitted to direct the plume away from the window.		
4.	If the pipe is shielded from the heat, this dimension may be reduced to 25 mm.		
5.	The flue through the roof should not be located within the shaded areas – R, S and T.		
6.	It is recommended that the terminal should not be located below 2 m in any occupied space.		
7.	Terminals below 2 m must be fitted with a suitable terminal guard and should be a minimum of 300 mm above surface level.		
8.	It is the installer's responsibility to carry out a suitable risk assessment to ensure the location of the terminal is safe and products can freely disperse without causing nuisance or harm to persons. Refer to IGEM/UP/10.		
9.	All flue terminations must be positioned such that the flue products can discharge freely from the terminal for rapid dispersal and cannot enter or re-enter a building, whilst ensuring they do not come into contact with objects or building fabrics as these could be damaged by the condensate.		

Minimum clearances for concentric terminations			
A	Directly below an opening, air brick, opening windows	2,500	Flue system to be designed and Installed according to IGEM UP/10. Use the risk assessment at appendix 9. Above 333 kW net heat input the clean air act must also be adhered to and system will need approval of local authority.
B	Above an opening, air brick, opening windows	900	
C	Horizontally to an opening, air brick, opening windows	900	
D (1,4,9)	Below metal gutter, drain/soil pipe (extending out to clear)	200*	
E (1,4,9)	Below eaves, adjacent to drain pipes	200	
F(6)	Below balcony or car port - must be extend to clear air	50	
G(4)	From a vertical drain pipes and soil pipes (extend out to clear)	50	
H(7,9)	From internal/external corner	300	
I(2,7)	To a boundary alongside the terminal/external corner	300	
J (2)	Facing a boundary or surface opposite	2,200	
Ja(2)	From a terminal opposite facing the terminal	3,000	
M (7)	Vertical from a terminal	1,500	
N (7)	Horizontally from a terminal	300	
O	Rosette to face of wall (can be extended up to 500mm *)	0	
* Terminal and wall entry must be sealed to prevent water ingress.			
Key	Vertical flues → 70 kW up to 120 kW	mm	All systems > 120 kW
Aa (8,9)	Within 2000mm horizontally of opening window.	2,500	Flue system to be designed and Installed according to IGEM UP/10. Above 333 kW net heat input the clean air act must also be adhered to and system will need approval of local authority.
C(2,3)	From adjacent non-opening window	1,000	
P (3,9)	From structure or (taller) building without openings or windows	300*	
Q	Above flat roof or intersection with pitched roof	600	
R(5)	Horizontal from opening windows on pitched or flat roofs	900	
S(5)	Above an opening roof light or windows on pitched roofs	600	
T(5)	Below an opening roof light or windows on pitched roofs	2,000	
*Products must disperse freely and not make contact with building surfaces			
<ol style="list-style-type: none"> There should be no ventilation/opening in the eaves within 900 mm of the terminal. These dimensions comply with the building regulations, but they may need to be increased to avoid wall staining and nuisance from plumbing depending on site conditions. It is recommended that an elbow termination is fitted to direct the plume away from the window. If the pipe is shielded from the heat, this dimension may be reduced to 25 mm. The flue through the roof should not be located within the shaded areas – R, S and T. It is recommended that the terminal should not be located below 2 m in any occupied space. Terminals below 2 m must be fitted with a suitable terminal guard and should be a minimum of 300 mm above surface level. It is the installer's responsibility to carry out a suitable risk assessment to ensure the location of the terminal is safe and products can freely disperse without causing nuisance or harm to persons. Refer to IGEM/UP/10. All flue terminations must be positioned such that the flue products can discharge freely from the terminal for rapid dispersal and cannot enter or re-enter a building, whilst ensuring they do not come into contact with objects or building fabrics as these could be damaged by the condensate. 			

I.3 Horizontal terminal positioning

Dimensions D, E, F and G:

These clearances may be reduced without affecting the performance of the boiler. In order to ensure that the condensate plume does not affect adjacent surfaces the terminal should be extended as shown below.

Appendix

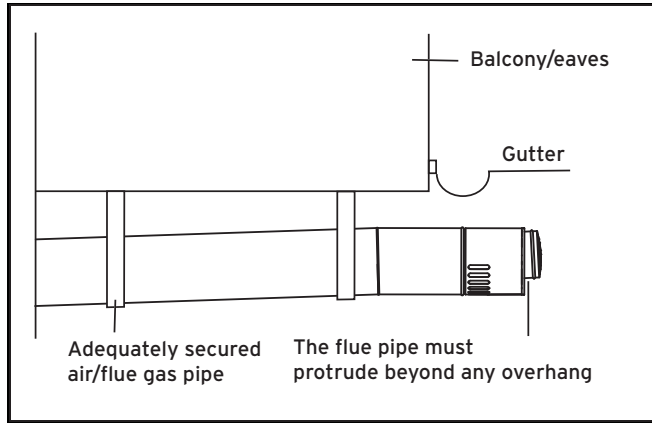

Horizontal Termination

J Treating the heating water

The information in the table below provides a general rule for classifying water hardness.

Hardness description	Total Hardness			
	mg/l Calcium carbonate (CaCO ₃)	UK Degrees Clark (°C)	French Degrees (°f)	German Degrees (°dH)
Soft	< 150	< 11	< 15	< 9
Hard	150 - 300	11 - 21	15 - 30	9 - 18
Very Hard	> 300	> 21	> 30	> 18

mg/l = milligrammes per litre = parts per million = ppm

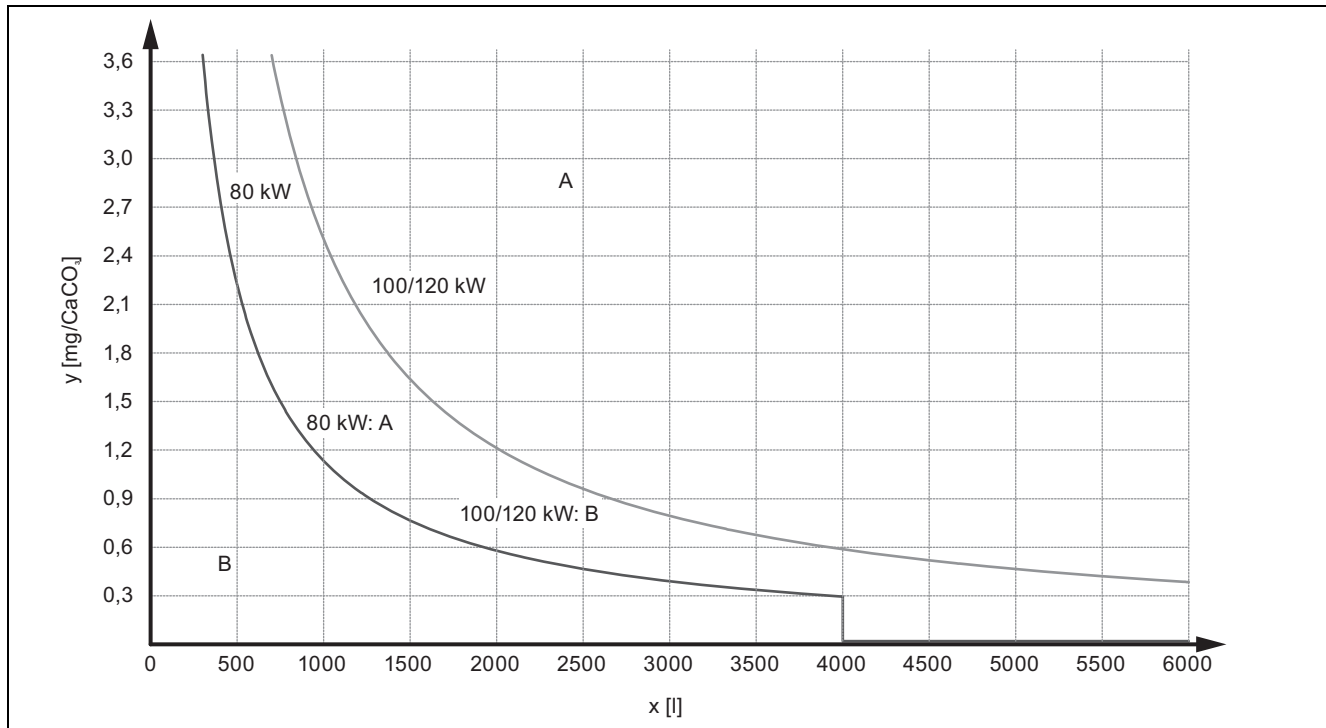

x	System volume	A	Water treatment required (water softener and inhibitor)
y	Water hardness [mg/l CaCO ₃]	B	Water treatment not required

K Technical data

Technical data – Output

	806 (VU GB 806/5-5)	1006 (VU GB 1006/5-5)	1206 (VU GB 1206/5-5)
Nominal heat output range at 50/30 °C	16.5 to 82.3 kW	20.7 to 102.8 kW	24.7 to 123.4 kW
Nominal heat output range at 60/40 °C	16.0 to 80.0 kW	20.0 to 100.0 kW	24.0 to 120.0 kW
Nominal heat output range at 80/60 °C	14.9 to 74.7 kW	18.7 to 93.3 kW	22.4 to 112.0 kW
Nominal efficiency (stationary) at 50/30 °C	108%	108%	108%
Nominal efficiency (stationary) at 60/40 °C	105%	105%	105%
Nominal efficiency (stationary) at 80/60 °C	98%	98%	98%
30% efficiency	109 %	109 %	109 %
Maximum heat input in heating mode (in relation to the net calorific value H_i and pure heating mode)	76.2 kW	95.2 kW	114.3 kW
Maximum heat input during cylinder charging	76.2 kW	95.2 kW	114.3 kW
Minimum heat input (in relation to the net calorific value H_i and pure heating mode)	15.2 kW	19.2 kW	22.9 kW

Technical data – Heating

	806 (VU GB 806/5-5)	1006 (VU GB 1006/5-5)	1206 (VU GB 1206/5-5)
Maximum flow temperature (default setting: 75 °C)	85 °C	85 °C	85 °C
Max. flow temperature adjustment range (default setting: 80 °C)	30 to 85 °C	30 to 85 °C	30 to 85 °C
Permissible total excess pressure	0.6 MPa (6.0 bar)	0.6 MPa (6.0 bar)	0.6 MPa (6.0 bar)
Circulation water volume (with reference to $\Delta T = 23$ K)	2,990 l/h	3,740 l/h	4,485 l/h
Approx. condensate quantity (pH value 3.5 to 4.0) in heating mode 40/30 °C	12.8 l/h	16.0 l/h	19.2 l/h
Remaining feed head of the high-efficiency pump	0.065 MPa (0.650 bar)	0.053 MPa (0.530 bar)	0.042 MPa (0.420 bar)

Technical data – General

	806 (VU GB 806/5-5)	1006 (VU GB 1006/5-5)	1206 (VU GB 1206/5-5)
Designated country (designation in accordance with ISO 3166)	GB (Great Britain), IE (Ireland)	GB (Great Britain), IE (Ireland)	GB (Great Britain), IE (Ireland)
Approval category	II _{2H3P}	II _{2H3P}	II _{2H3P}
Gas connection, boiler side	R 1	R 1	R 1
Flow/return heating connections, boiler side	G 1 1/4"	G 1 1/4"	G 1 1/4"
G20 natural gas flow pressure	2.0 kPa (20.0 mbar)	2.0 kPa (20.0 mbar)	2.0 kPa (20.0 mbar)
Gas flow rate at 15 °C and 1013 mbar (based on domestic hot water generation if applicable), G20 ($H_i = 9.5$ kWh/m ³)	8.0 m ³ /h	10.1 m ³ /h	12.1 m ³ /h
Min. flue gas mass flow rate (G20)	6.9 g/s	8.9 g/s	10.6 g/s
Max. flue gas mass flow rate	34.4 g/s	43.6 g/s	52.5 g/s
Min. flue gas temperature	40 °C	40 °C	40 °C
Max. flue gas temperature	85 °C	85 °C	85 °C
Approved flue connections	C13, C33, C43, C53, C93, B23, B53, B53P	C13, C33, C43, C53, C93, B23, B53, B53P	C13, C33, C43, C53, C93, B23, B53, B53P
Additional approved flue connections	B23P	B23P	B23P
Permissible pressure difference in the flue pipe for installation type B23P as a single-flue configuration max.	150 Pa (0.00150 bar)	200 Pa (0.00200 bar)	200 Pa (0.00200 bar)
Permitted pressure difference in the flue pipe for installation type B23P as cascade operation max.	50 Pa (0.00050 bar)	50 Pa (0.00050 bar)	50 Pa (0.00050 bar)

Appendix

	806 (VU GB 806/5-5)	1006 (VU GB 1006/5-5)	1206 (VU GB 1206/5-5)
Air/flue gas connection	110/160 mm	110/160 mm	110/160 mm
NOx class	6	6	6
NOx emissions	≤ 40 mg/kW·h	≤ 40 mg/kW·h	≤ 40 mg/kW·h
CO emissions	≤ 30 mg/kW·h	≤ 30 mg/kW·h	≤ 30 mg/kW·h
CO₂ content min. volume	8.8 vol%	9.0 vol%	9.0 vol%
CO₂ content max. volume	9.0 vol%	9.0 vol%	9.0 vol%
Unit dimensions, width	480 mm	480 mm	480 mm
Unit dimensions, height	960 mm	960 mm	960 mm
Unit dimensions, depth	603 mm	603 mm	603 mm
Approx. net weight without pump group	68 kg	86 kg	90 kg

Technical data – Electrical

	806 (VU GB 806/5-5)	1006 (VU GB 1006/5-5)	1206 (VU GB 1206/5-5)
Electrical connection	230 V/50 Hz	230 V/50 Hz	230 V/50 Hz
Built-in fuse (slow-blow)	4 A	4 A	4 A
Min. electrical power consumption	25 W	18 W	18 W
Max. electrical power consumption	122 W	160 W	160 W
Standby electrical power consumption	< 2 W	< 2 W	< 2 W
IP rating	IP X4 D	IP X4 D	IP X4 D
Test symbol/registration no.	CE- 0085CM0415	CE- 0085CM0415	CE- 0085CM0415

Index

A

Additional relay	20
Air index setting	23
Air/flue pipe	15
Air/flue pipe, installed	6
Automatic air vent.....	21

B

Basic diagram.....	4
Burner.....	31, 35
Burner anti-cycling time	26

C

Casing, upper.....	10
CE marking.....	8
Check programme.....	19
Check programmes	18, 20, 34
Circulation pump	17
CO ₂ content.....	23
Combustion air supply.....	5
Comfort mode.....	19
Comfort protection mode.....	33
Compact thermal module	5
Competent person.....	4
Competent person telephone number.....	20
Component test.....	29
Condensate discharge pipe.....	14
Condensate trap.....	21, 32
Connection dimensions	9
Control.....	17
Corrosion.....	5
Corrugated gas pipe.....	5

D

Data plate.....	8
Decommissioning.....	36
Deleting, fault list.....	34
Diagnostics.....	34
Diagnostics codes	25, 39
Display.....	36
Disposal, packaging	36
Disposing of the packaging	36
Documents	7
Draining	33

E

Electricity.....	6
Electronics self-test	29
Expansion relief valve	14

F

Fan	35
Fault codes.....	33, 43
Fault list.....	34
Fault memory	33–34
Fault symbol.....	20
Filling.....	21
Filling mode.....	19
Filling pressure.....	20
Flow temperature, maximum.....	25
Flue gas route	5
Front casing.....	10
Front casing, closed	6
Frost.....	6
Function menu.....	29

G

Gas connection	11
Gas conversion	22
Gas setting	22
Gas type	12
Gas valve assembly	34
Gas-air mixture unit.....	29, 32

H

Heat exchanger	31, 35
Heating flow.....	13
Heating return.....	13
Heating system.....	21
Hot water temperature.....	19

I

If you smell flue gas.....	5
If you smell gas	5
Inspection work	28, 33, 41
Installation assistant.....	19–20
Installation clearances.....	9
Installation site.....	5
Installer level	18
Insulating mat.....	35
Intended use.....	4

L

Language	19
Leak-tightness	24
Liquid gas	5, 12
Live Monitor.....	18

M

Mains connection	16
Maintenance interval	26
Maintenance work	28, 33, 41
Minimum clearances	9
Multi-functional module	20

O

Open-flued operation.....	5
Operating concept.....	18

P

Parameters.....	34
Partial heat load	19, 25
PCB.....	36
Power supply.....	16
Preparing, repair work	34
Pressure	20
Product.....	28
Product dimensions.....	9
Pump mode.....	25
Pump output.....	26
Pump overrun.....	25
Purging.....	21

Q

Qualification.....	4
--------------------	---

R

Regulations	6
Repair.....	34, 36
Replacing the burner.....	35
Replacing, display	36
Replacing, fan	35
Replacing, gas valve assembly	34
Replacing, heat exchanger.....	35
Replacing, PCB.....	36
Resetting the remaining burner anti-cycling time	26

Index

Resetting, fault memory	34
Resetting, parameters	34
Return temperature control	26
Risk of scalding	6
S	
Safety device	4
Scope of delivery	8
Self-test	29
Service message	33
Service partner	33
Side section	11
Spare parts	28–29
Status codes	18, 42
Switching on	19
T	
Target feed temperature	19
Test programmes	18
Tool	6
Transport	4
Treating the heating water	18
U	
Unit configuration	20
V	
Voltage	6
W	
Weight	9

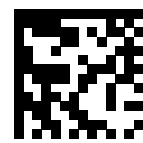

0020134823_07

0020134823_07 ■ 27.02.2019

Supplier

Vaillant Ltd.

Nottingham Road ■ Belper 1■1 Derbyshire 1■1 DE56 1JT

Telephone 0330 100 3461

info@vaillant.co.uk ■ www.vaillant.co.uk

© These instructions, or parts thereof, are protected by copyright and may be reproduced or distributed only with the manufacturer's written consent.

Subject to technical modifications.