

Installation and maintenance instructions



ecoTEC plus

VU 446/5-5 (H-GB)

VU 606/5-5 (H-GB)

GB, IE, NZ

Publisher/manufacturer

Vaillant GmbH

Berghauser Str. 40 ■ D-42859 Remscheid
Tel. +492191 18 0 ■ Fax +492191 18 2810
info@vaillant.de ■ www.vaillant.de



Contents

Contents

| | | | | | |
|----------|-------------------------------------------------------------------------------|-----------|-----------------------|---------------------------------------------------------------------|-----------|
| 1 | Safety | 3 | 7.6 | Running the installation assistants | 24 |
| 1.1 | Action-related warnings | 3 | 7.7 | Preventing low water pressure | 25 |
| 1.2 | Intended use | 3 | 7.8 | Flushing the heating installation for the first time ("cold") | 25 |
| 1.3 | General safety information | 3 | 7.9 | Using check programmes | 25 |
| 1.4 | Regulations (directives, laws, standards) | 6 | 7.10 | Check and gas setting | 25 |
| 2 | Notes on the documentation | 7 | 7.11 | Checking leak-tightness | 28 |
| 2.1 | Observing other applicable documents | 7 | 7.12 | Thoroughly flushing the heating installation ("hot") | 29 |
| 2.2 | Storing documents | 7 | 8 | Adapting the unit to the heating installation | 29 |
| 2.3 | Validity of the instructions | 7 | 8.1 | Activating diagnostics codes | 29 |
| 2.4 | Benchmark | 7 | 8.2 | Adapting the heating settings | 29 |
| 3 | Product description | 7 | 8.3 | Setting the maintenance interval | 31 |
| 3.1 | Product design | 7 | 9 | Handing over to the end user | 31 |
| 3.2 | Data plate | 7 | 10 | Troubleshooting | 31 |
| 3.3 | Serial number | 8 | 10.1 | Contacting your service partner | 31 |
| 3.4 | SVGW (Swiss Gas and Water Industry Association) symbol | 8 | 10.2 | Calling up service messages | 31 |
| 3.5 | CE marking | 8 | 10.3 | Reading off the fault codes | 31 |
| 3.6 | Energy Saving Trust Endorsed Products | 8 | 10.4 | Querying the fault memory | 32 |
| 4 | Set-up | 8 | 10.5 | Resetting the fault memory | 32 |
| 4.1 | Unpacking the product | 8 | 10.6 | Performing diagnostics | 32 |
| 4.2 | Checking the scope of delivery | 8 | 10.7 | Using check programmes | 32 |
| 4.3 | Transporting the product | 9 | 10.8 | Resetting parameters to factory settings | 32 |
| 4.4 | Dimensions | 9 | 10.9 | Replacing defective components | 32 |
| 4.5 | Minimum clearances | 10 | 11 | Inspection and maintenance | 36 |
| 4.6 | Clearance from combustible components | 10 | 11.1 | Using the function menu | 37 |
| 4.7 | Using the mounting template | 10 | 11.2 | Carrying out electronics self-tests | 37 |
| 4.8 | Wall-mounting the product | 10 | 11.3 | Cleaning/checking the components | 37 |
| 4.9 | Removing/installing the front casing | 10 | 11.4 | Draining the product | 40 |
| 4.10 | Removing/installing the side section | 11 | 11.5 | Completing inspection and maintenance work | 41 |
| 5 | Installation | 12 | 12 | Decommissioning | 41 |
| 5.1 | Sample system installations | 12 | 12.1 | Permanently decommissioning | 41 |
| 5.2 | Selecting the domestic hot water cylinder | 15 | 13 | Recycling and disposal | 41 |
| 5.3 | Selecting a low loss header | 15 | 14 | Customer service | 41 |
| 5.4 | Requirements | 15 | Appendix | 42 | |
| 5.5 | Connecting gas and water | 16 | A | Overview of diagnostics codes | 42 |
| 5.6 | Installing and connecting the air pipe and flue pipe | 18 | B | Status codes – Overview | 45 |
| 5.7 | Electrical installation | 19 | C | Fault messages – Overview | 46 |
| 6 | Operation | 21 | D | Wiring diagram | 50 |
| 6.1 | Operating concept | 21 | E | Basic installation diagram | 52 |
| 6.2 | Calling up the installer level | 21 | E.1 | 0020253233 | 52 |
| 6.3 | Live Monitor (status codes) | 21 | E.2 | 0020259030 | 53 |
| 6.4 | Calling up appliance config. and diagnostics menu | 21 | E.3 | Key for the basic system diagrams | 54 |
| 6.5 | Using test programmes | 21 | F | Inspection and maintenance work – Overview | 54 |
| 7 | Start-up | 21 | G | Commissioning Checklist | 56 |
| 7.1 | Carrying out the initial start-up | 21 | H | Position of the opening in the air/flue pipe | 60 |
| 7.2 | Checking and treating the heating water/filling and supplementary water | 21 | H.1 | Positioning of the opening of a fan-supported flue gas pipe | 60 |
| 7.3 | Filling the condensate siphon | 23 | I | Horizontal terminal positioning | 61 |
| 7.4 | Filling the heating installation | 23 | J | Gas adjustment values | 61 |
| 7.5 | Starting up the product | 24 | K | Technical data | 62 |
| | | | Index | 64 | |

1 Safety

1.1 Action-related warnings

Classification of action-related warnings

The action-related warnings are classified in accordance with the severity of the possible danger using the following warning signs and signal words:

Warning symbols and signal words



Danger!

Imminent danger to life or risk of severe personal injury



Danger!

Risk of death from electric shock



Warning.

Risk of minor personal injury



Caution.

Risk of material or environmental damage

1.2 Intended use

There is a risk of injury or death to the user or others, or of damage to the product and other property in the event of improper use or use for which it is not intended.

The product is intended as a heat generator for closed heating installations and for domestic hot water generation.

Depending on the unit type, the products referred to in these instructions must only be installed and operated in conjunction with the air/flue pipe accessories listed in the other applicable documents.

The use of the product in vehicles, such as mobile homes and caravans, is not classed as intended use. Units that are not classed as vehicles are those that are installed in a fixed and permanent location (known as "fixed installation").

Intended use includes the following:

- observance of accompanying operating, installation and maintenance instructions for the product and any other system components
- installing and setting up the product in accordance with the product and system approval

- compliance with all inspection and maintenance conditions listed in the instructions.

Intended use also covers installation in accordance with the IP code.

Any other use that is not specified in these instructions, or use beyond that specified in this document, shall be considered improper use. Any direct commercial or industrial use is also deemed to be improper.

Caution.

Improper use of any kind is prohibited.

1.3 General safety information

1.3.1 Risk caused by inadequate qualifications

The following work must only be carried out by competent persons who are sufficiently qualified to do so:

- Set-up
- Dismantling
- Installation
- Start-up
- Inspection and maintenance
- Repair
- Decommissioning
- ▶ Proceed in accordance with current technology.

1.3.2 Risk of death from escaping gas

Applicability: Except Great Britain, Except Ireland

What to do if you smell gas in the building:

- ▶ Avoid rooms that smell of gas.
- ▶ If possible, open doors and windows fully and ensure adequate ventilation.
- ▶ Do not use naked flames (e.g. lighters, matches).
- ▶ Do not smoke.
- ▶ Do not use any electrical switches, mains plugs, doorbells, telephones or other communication systems in the building.
- ▶ Close the emergency control valve or the main isolator.
- ▶ If possible, close the gas isolator cock on the product.



1 Safety

- ▶ Warn other occupants in the building by yelling or banging on doors or walls.
- ▶ Leave the building immediately and ensure that others do not enter the building.
- ▶ Alert the police and fire brigade as soon as you are outside the building.
- ▶ Use a telephone outside the building to inform the emergency service department of the gas supply company.

1.3.3 Risk of death from escaping gas

Applicability: Great Britain

OR Ireland

What to do if you smell gas in the building:

- ▶ Avoid rooms that smell of gas.
- ▶ If possible, open doors and windows fully and ensure adequate ventilation.
- ▶ Do not use naked flames (e.g. lighters, matches).
- ▶ Do not smoke.
- ▶ Do not use any electrical switches, mains plugs, doorbells, telephones or other communication systems in the building.
- ▶ If it is safe to do so, close the emergency control valve or the main isolator.
- ▶ If possible, close the gas stopcock on the product.
- ▶ Warn other occupants in the building by yelling or banging on doors or walls.
- ▶ Leave the building immediately and ensure that others do not enter the building.
- ▶ Notify the gas supply company or the National Grid +44 (0) 800 111999 by telephone once you are outside of the building.

1.3.4 Risk of death from leaks if the product is installed below ground level

Liquid gas accumulates at floor level. If the product is installed below ground level, liquid gas may accumulate at floor level if there are any leaks. In this case, there is a risk of explosion.

- ▶ Make sure that liquid gas cannot escape from the product or the gas pipe under any circumstances.

1.3.5 Risk of death due to blocked or leaking flue gas routes

Installation errors, damage, tampering, impermissible installation sites or similar can cause flue gas to escape and result in a risk of poisoning.

What to do if you smell flue gas in the property:

- ▶ Open all accessible doors and windows fully to provide ventilation.
- ▶ Switch off the product.
- ▶ Check the flue gas routes in the product and the flue gas diversions.

1.3.6 Risk of death due to explosive and flammable materials

- ▶ Do not use the product in storage rooms that contain explosive or flammable substances (such as petrol, paper or paint).

1.3.7 Risk of death due to lack of safety devices

The basic diagrams included in this document do not show all safety devices required for correct installation.

- ▶ Install the necessary safety devices in the installation.
- ▶ Observe the applicable national and international laws, standards and directives.

1.3.8 Risk of death from electric shock

There is a risk of death from electric shock if you touch live components.

Before commencing work on the product:

- ▶ Unplug the mains plug.
- ▶ Or disconnect the product from the power supply by switching off all power supplies (electrical partition with a contact gap of at least 3 mm, e.g. fuse or circuit breaker).
- ▶ Secure against being switched back on again.
- ▶ Wait for at least 3 minutes until the capacitors have discharged.
- ▶ Check that there is no voltage.





1.3.9 Risk of death from escaping flue gas

Applicability: Not for Great Britain

If you operate the product with an empty condensate siphon, flue gas may escape into the room air.

- ▶ In order to operate the product, ensure that the condensate siphon is always full.

Condition: Permitted B23 or B23P unit types with condensate siphon (third-party accessory)

- Water seal level: ≥ 200 mm

1.3.10 Risk of death from escaping flue gas

Applicability: Great Britain

If you operate the product with an empty condensate trap / siphon, then flue gas may escape into the room air.

- ▶ In order to operate the product, ensure that the condensate trap / siphon is always full.

Condition: Permitted B23 or B23P unit types with condensate siphon (third-party accessory)

- Water seal level: ≥ 200 mm

1.3.11 Risk of death due to cabinet-type casing

Cabinet-type casing can give rise to dangerous situations when used on a product which is operated with an open flue.

- ▶ Ensure that the product is supplied with sufficient combustion air.

1.3.12 Risk of poisoning caused by insufficient combustion air supply

Condition: Open-flued operation

- ▶ Ensure that the air supply to the product's installation room is permanently unobstructed and sufficient in accordance with the relevant ventilation requirements.

1.3.13 Risk of poisoning and burns caused by escaping hot flue gases

- ▶ Only operate the product if the air/flue pipe has been completely installed.
- ▶ With the exception of short periods for testing purposes, only operate the product

when the front casing is installed and closed.

1.3.14 Risk of being burned or scalded by hot components

- ▶ Only carry out work on these components once they have cooled down.

1.3.15 Risk of injury due to the heavy weight of the product

- ▶ Make sure that the product is transported by at least two people.

1.3.16 Risk of material damage caused by using an unsuitable tool

- ▶ Use the correct tool.

1.3.17 Risk of material damage caused by frost

- ▶ Do not install the product in rooms prone to frost.

1.3.18 Risk of corrosion damage due to unsuitable combustion and room air

Sprays, solvents, chlorinated cleaning agents, paint, adhesives, ammonia compounds, dust or similar substances may lead to corrosion on the product and in the flue system.

- ▶ Ensure that the supply of combustion air is always free of fluorine, chlorine, sulphur, dust, etc.
- ▶ Ensure that no chemical substances are stored at the installation site.
- ▶ If you are installing the product in hairdressing salons, painter's or joiner's workshops, cleaning businesses or similar locations, choose a separate installation room in which the room air is technically free of chemical substances.

Applicability: Except Great Britain

- ▶ Ensure that the combustion air is not routed through chimneys which have previously been used with floor-standing oil-fired boilers, or with other boilers, which could cause soot to build up in the chimney.





1 Safety

1.3.19 Risk of material damage caused by leak detection sprays and fluids

Leak detection sprays and fluids block the filter for the mass flow sensor on the Venturi, thereby destroying the mass flow sensor.

- ▶ During repair work, do not apply any leak detection sprays or fluids to the covering cap on the filter for the Venturi.

1.3.20 Risk of damage to the flexible gas pipe

The corrugated gas pipe may become damaged if weight is placed on it.

- ▶ Do not suspend the compact thermal module on the flexible gas pipe, for example during maintenance work.

1.4 Regulations (directives, laws, standards)

- ▶ Observe the national regulations, standards, directives, ordinances and laws.



2 Notes on the documentation

2.1 Observing other applicable documents

- ▶ Always observe all the operating and installation instructions included with the system components.

2.2 Storing documents

- ▶ Pass these instructions and all other applicable documents on to the end user.

2.3 Validity of the instructions

These instructions apply only to:

Product article number

| | |
|-------------------------------|------------|
| VU 446/5-5 (H-GB) ecoTEC plus | 0010021520 |
| VU 606/5-5 (H-GB) ecoTEC plus | 0010021521 |

Gas Council Number

| | |
|-------------------------------|-----------|
| VU 446/5-5 (H-GB) ecoTEC plus | 41-694-28 |
| VU 606/5-5 (H-GB) ecoTEC plus | 41-694-29 |

2.4 Benchmark

Applicability: Great Britain

Vaillant is a licensed member of the Benchmark Scheme.

Benchmark places responsibilities on both manufacturers and installers. The purpose is to ensure that customers are provided with the correct equipment for their needs, that it is installed, commissioned and serviced in accordance with the manufacturer's instructions by a competent person approved at the time by the Health and Safety Executive and that it meets the requirements of the appropriate Building Regulations. The Benchmark Checklist can be used to demonstrate compliance with Building Regulations and should be provided to the customer for future reference.

Installers are required to carry out installation, commissioning and servicing work in accordance with the Benchmark Code of Practice which is available from the Heating and Hotwater Industry Council who manage and promote the Scheme.

Benchmark is managed and promoted by the Heating and Hotwater Industry Council.



For more information visit www.centralheating.co.uk

3 Product description

This product is a gas-fired wall-hung condensing boiler.

3.1 Product design

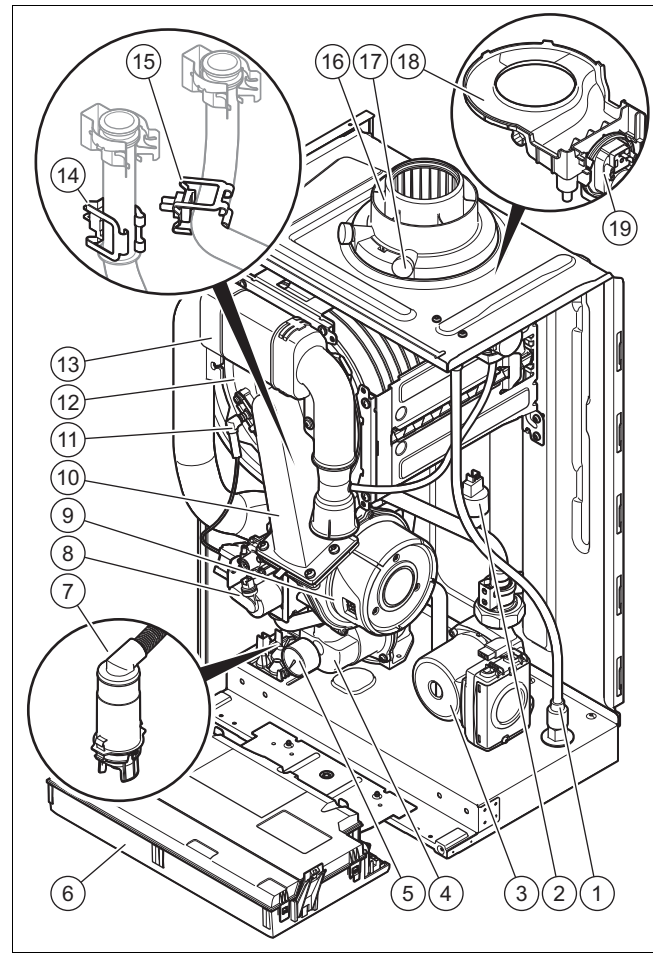

- | | |
|---------------------------------|---------------------------------------------|
| 1 Rainwater drain hose | 11 Ignition electrode |
| 2 Hydraulic pressure sensor | 12 Integrated condensation heat exchanger |
| 3 Heating pump | 13 Air intake pipe |
| 4 Dynamic air separation system | 14 Temperature sensor in the heating flow |
| 5 Water-pressure manometer | 15 Temperature sensor in the heating return |
| 6 Electronics box | 16 Connection for the air/flue pipe |
| 7 Condensate siphon | 17 Flue gas measuring stub pipe |
| 8 Gas valve assembly | 18 Rainwater collecting device |
| 9 Fan | 19 Pressure switch |
| 10 Compact thermal module | |

3.2 Data plate

The data plate is mounted on the underside of the product in the factory.

| Information on the data plate | Meaning |
|-------------------------------|----------------------------|
| | Barcode with serial number |

4 Set-up

| Information on the data plate | Meaning |
|-------------------------------------------------------------------------------------|--------------------------------------------------------------------------------------------------------------------------------------------------------------------------------------------------------------------------------------------------------------------------------------------------------|
| Serial number | For quality control purposes; 3rd and 4th digits = year of production For quality control purposes; 5th and 6th digits = week of production For identification purposes; 7th to 16th digits = product article number For quality control purposes; 17th to 20th digits = place of manufacture |
| ... ecoTEC Plus ... | Product designation |
| 2H / 2E / 3P / 2L... | Gas group and gas connection pressure as set at the factory |
| I12H3P / I2E / I3P... | Approved gas category |
| Condensing technology | Efficiency class of the boiler in accordance with EC Directive 92/42/EEC |
| Type: Xx3(x) | Permissible flue gas connections |
| PMS | Maximum water pressure in heating mode |
| V Hz | Electrical connection – Voltage – Frequency |
| Hi | Lower gross calorific value |
| W | Max. electrical power consumption |
| IP | Protection class |
| III | Heating mode |
| Qn | Nominal heating load range in heating mode |
| Pn | Nominal heat output range in heating mode |
| Pnc | Nominal heat output range in heating mode (condensing technology) |
| Tmax | Maximum flow temperature |
| NOx | NOx class for the product |
| Code (DSN) | Specific product code |
|  | Read the instructions. |



Note

Make absolutely sure that the product is compatible with the gas group at the installation site.

3.3 Serial number

The serial number can be found on the identification plate.

3.4 SVGW (Swiss Gas and Water Industry Association) symbol

3.5 CE marking



The CE marking shows that the products comply with the basic requirements of the applicable directives as stated on the data plate.

The declaration of conformity can be viewed at the manufacturer's site.

3.6 Energy Saving Trust Endorsed Products

Applicability: Great Britain



Only the most energy efficient products can carry the 'Energy Saving Trust Endorsed Product' brandmark making it easy for consumers to choose products that have met strict energy performance criteria.

Available for: Boilers, Heating controls and chemical inhibitors, the Energy Saving Trust endorsed product brandmark gives consumers confidence that a product will cost less to run, help lower energy bills and reduce carbon emissions.

About the Energy Saving Trust

Energy Saving Trust is an independent and impartial organisation that provides trusted energy saving advice to empower millions of people to lead affordable, low energy lifestyles. For more information visit energysavingtrust.org.uk

4 Set-up

4.1 Unpacking the product

1. Remove the product from its box.
2. Remove the wedge and protective film from all of the product's components.

4.2 Checking the scope of delivery

Applicability: VU 446/5-5 (H-GB)

OR VU 606/5-5 (H-GB)

- Check that the scope of delivery is complete and intact.

| Number | Designation |
|--------|-------------------------------------------------------------------------------------------------------------|
| 1 | Heat generator |
| 1 | Bag of set-up parts with retainer for wall-mounting, fastening accessories and condensate discharge hose |
| 1 | Cardboard box for the hydraulic connection with expansion relief valve, drain cock, air separator and seals |
| 1 | Cardboard box with the stopcocks for the heating circuit |
| 1 | Cardboard box with the stopcock for the gas line assembly |
| 1 | Documentation material including gas conversion set |

4.3 Transporting the product

Applicability: Great Britain

OR Ireland

Important: With regard to the regulations of 1992 concerning the manual handling of loads, the product exceeds the weight that can be lifted by a single person.

4.3.1 General

Applicability: Great Britain

OR Ireland

- ▶ Hold the load as close as possible to your body. Avoid rotational movements. Instead, reposition your feet.
- ▶ If the product is being lifted by two persons, ensure your movements are coordinated during lifting.
- ▶ Avoid bending your upper body – do not lean forwards or to the side.
- ▶ Wear suitable non-slip protective gloves in order to protect your hands against sharp edges. Ensure that you are carrying the load securely.
- ▶ If required, get somebody to assist you in this.

4.3.2 Unloading the cardboard box from the delivery van

Applicability: Great Britain

OR Ireland

- ▶ It is recommended that two people lift the product together.
- ▶ Use safe lifting techniques – keep your back straight and bend your legs at the knee.
- ▶ Hold the load as close as possible to your body.
- ▶ If the product is being lifted by two persons, ensure your movements are coordinated during lifting.
- ▶ If required, get somebody to assist you in this.

4.3.3 Transporting the cardboard box from the delivery point to the installation site – ground floor

Applicability: Great Britain

OR Ireland

- ▶ It is recommended that two people lift the product together.
- ▶ Use safe lifting techniques – keep your back straight and bend your legs at the knee.

4.4 Dimensions

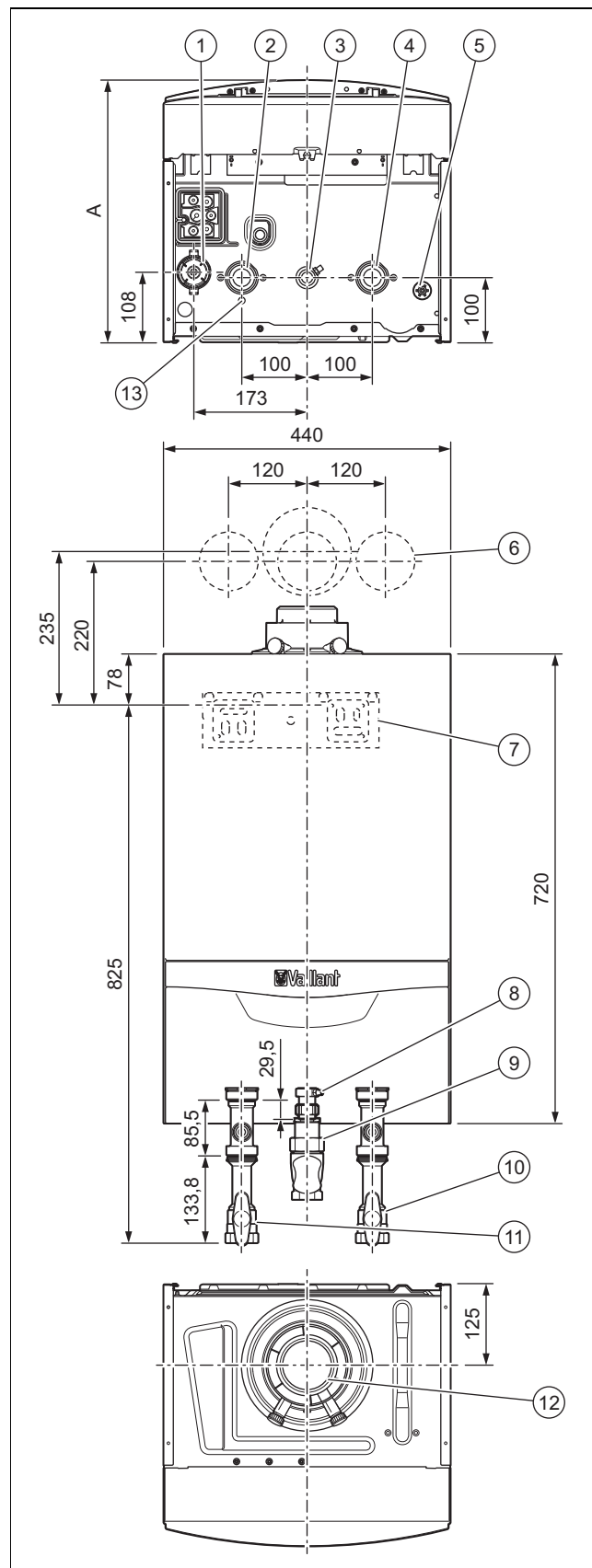

- | | | | |
|---|---------------------------|---|-------------------------------------------|
| 1 | Condensate siphon | 5 | Drain for the rainwater collecting device |
| 2 | Heating flow connection | 6 | Position of the holes for the flue system |
| 3 | Gas connection | 7 | Retainer for securing the product |
| 4 | Heating return connection | | |

4 Set-up

| | | | |
|----|--------------------------------|----|---------------------------------------------|
| 8 | Gas pressure connection | 11 | Stopcock in the heating flow |
| 9 | Gas stopcock | 12 | Connection for the air/flue pipe |
| 10 | Stopcock in the heating return | 13 | Drain for the dynamic air separation system |

Dimension A

| | |
|-------------------|--------|
| VU 446/5-5 (H-GB) | 405 mm |
| VU 606/5-5 (H-GB) | 473 mm |

4.5 Minimum clearances

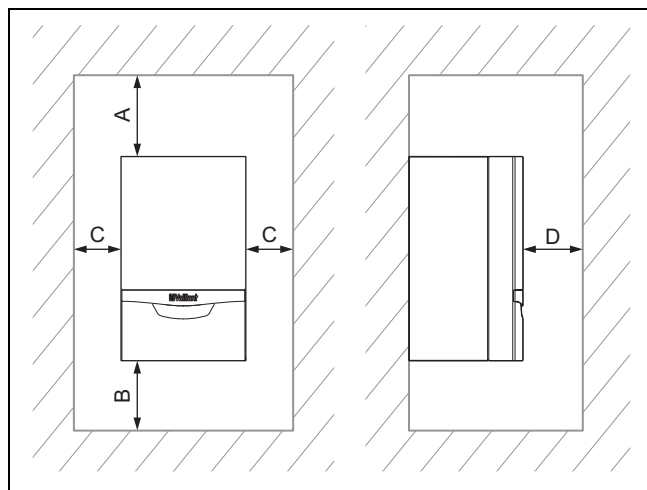

- ▶ When using the accessories, observe the minimum clearances/installation clearances.

Minimum clearances

| A | B | C | D |
|----------|----------|--------|----------|
| ≥ 275 mm | ≥ 180 mm | ≥ 5 mm | ≥ 500 mm |

- Optimum dimension (B): ≈ 250 mm
- Optimum dimension (C): ≈ 50 mm
- Dimension (D): The clearance in front of the product to facilitate easy access for maintenance work can be reduced to 5 mm if there is a door in front of the product

4.6 Clearance from combustible components

It is not necessary to maintain a clearance between the product and components made of combustible materials that go beyond the minimum clearances.

4.7 Using the mounting template

- ▶ Use the mounting template to ascertain the locations at which you need to drill holes and make breakthroughs.

4.8 Wall-mounting the product

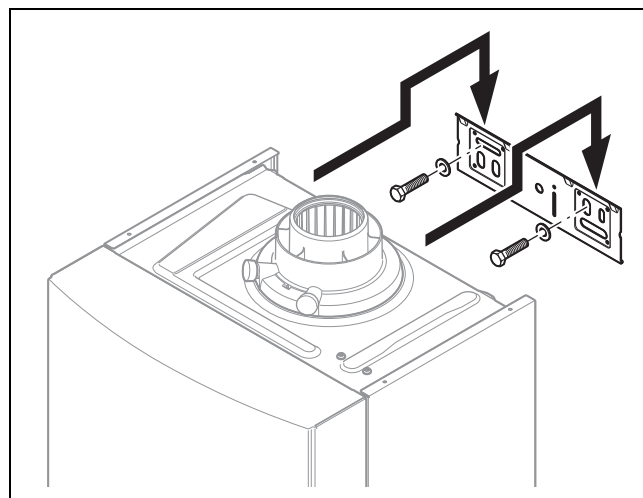

1. Check the load-bearing capacity of the wall.
2. Note the total weight of the product.
3. Only use fixing material that is permitted for the wall.
4. If required, ensure that mounting apparatus on-site has sufficient load-bearing capacity.
5. Wall-mount the product as described.

4.9 Removing/installing the front casing

4.9.1 Removing the front casing

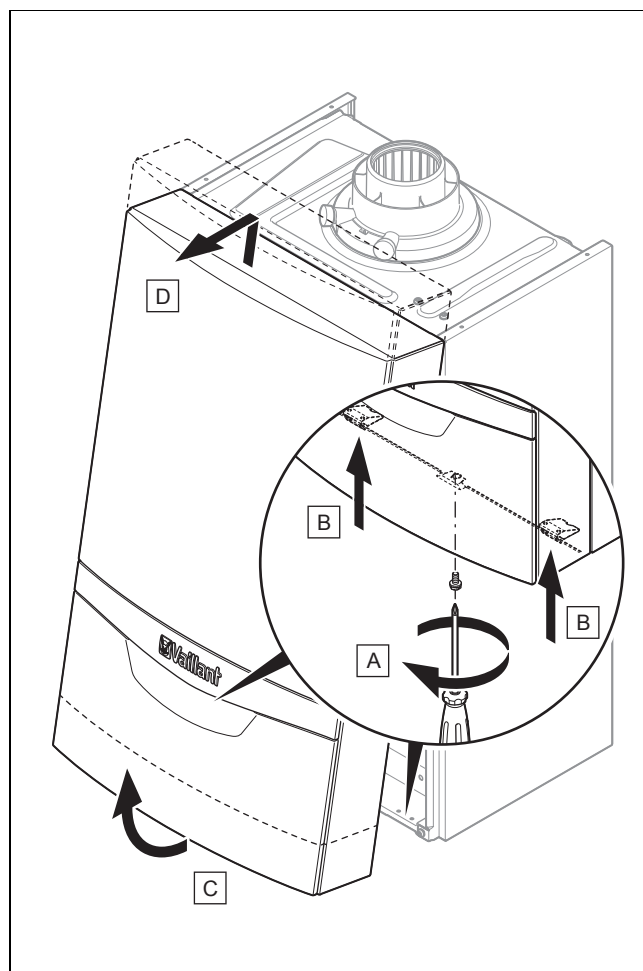

1. Undo the screw (A).
2. Push in both retaining clips (B) so that the front casing is released.

3. Pull the front casing forwards at the bottom edge (C).
4. Lift the front casing upwards from the bracket (D).

4.9.2 Installing the front casing

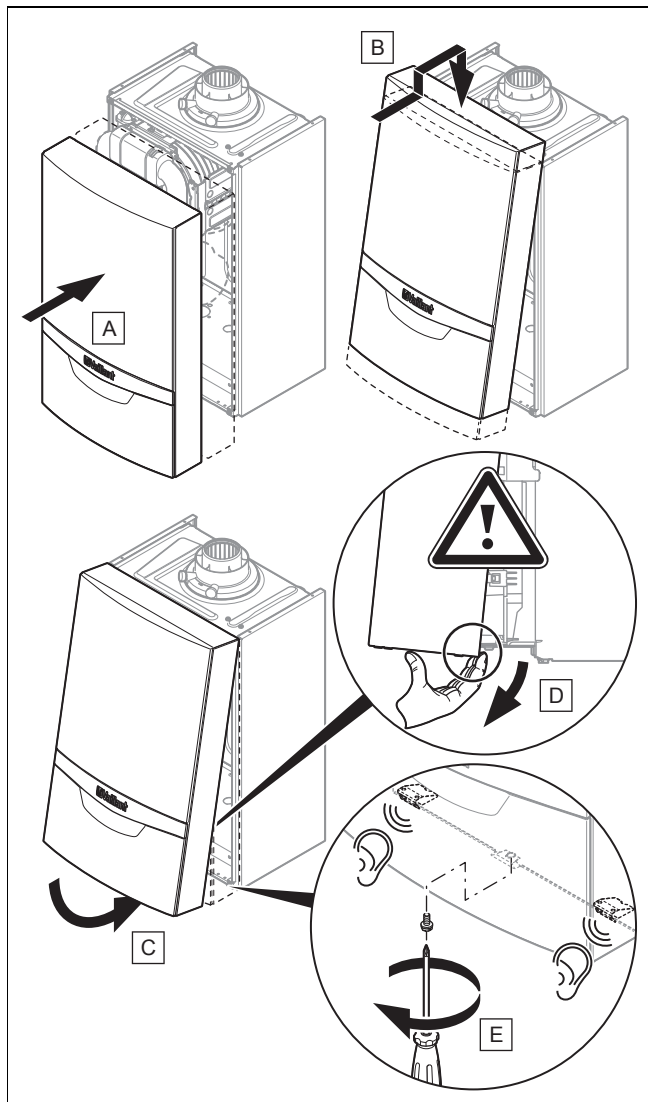

1. Place the front casing (A) on the upper retainer (B).
2. Hinge the front casing down in the direction of the product (C).
3. Push the front casing onto the product and, in doing so, ensure that the insulation is not damaged (D).
4. Let the retaining clips on the front casing snap into place.
5. Tighten the screw (E) in order to secure the front casing.

4.10 Removing/installing the side section

4.10.1 Removing the side section



Caution.

Risk of material damage caused by mechanical deformation.

Removing both side sections may cause mechanical distortion in the product, which may cause damage to the piping, for example, and potentially result in leaks.

- ▶ Always only remove one side section – never both side sections at the same time.

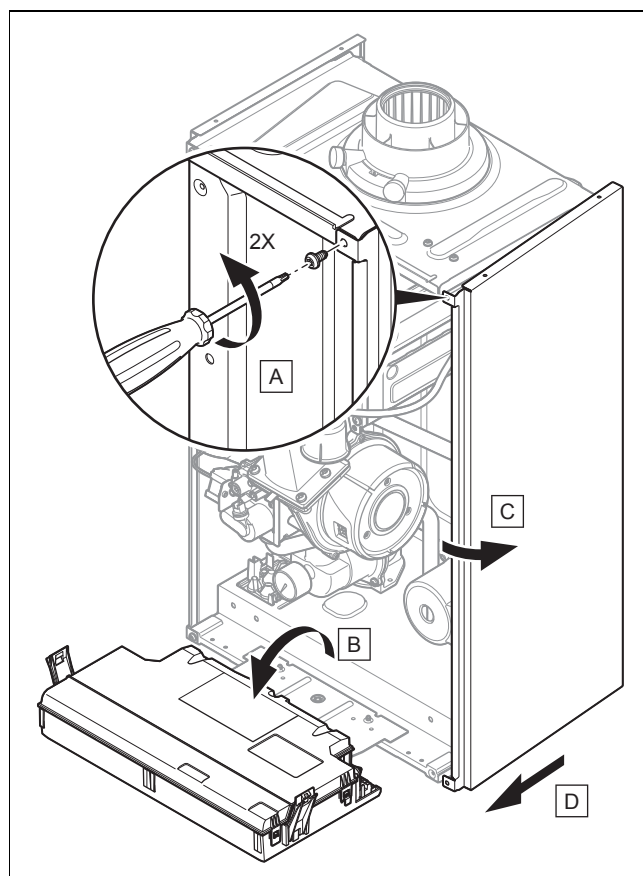

- ▶ Remove the side section as shown in the illustration.

4.10.2 Installing the side section

- ▶ Install the side section; to do so, proceed in reverse order to how you removed it.

5 Installation

5 Installation

5.1 Sample system installations

- ▶ Use the basic installation diagrams as examples.
- ▶ Select the basic installation diagram based upon which you want to configure your installation.
- ▶ Only install the control systems that are listed in the tables for the basic system diagrams in order to ensure that all of the system's functions are available.
- ▶ Establish the connections correctly.
- ▶ Observe the applicable national and international laws, standards and directives.
- ▶ With older installations in particular, install a magnetic filter at the heating circuit return in order to protect the product against dirt from the installation.
 - Ensure that there is sufficient dimensioning in order to prevent it from blocking quickly and to prevent high pressure losses.
- ▶ Observe the information on treating heating water. (→ Page 21)
 - ▽ If you cannot guarantee the conditions for treating the heating water, install an external plate heat exchanger to protect the product.
- ▶ Install the required safety devices and system components in the installation.

5.1.1 Basic system diagram type 1: One direct heating circuit with one optional domestic hot water cylinder



Note

This basic diagram type can then only be used if the product's pump is the only pump in the system.

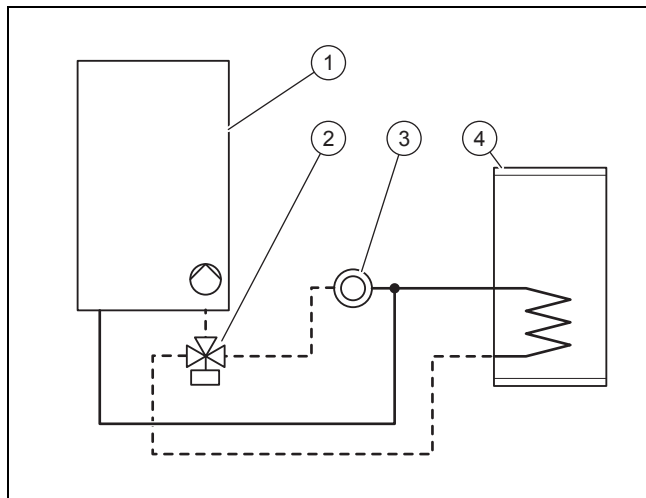

- | | | | |
|---|-------------------------------------|---|-----------------------------|
| 1 | Wall-hung boiler with internal pump | 3 | Heating circuit |
| 2 | Prioritising diverter valve | 4 | Domestic hot water cylinder |

- ▶ To use this basic diagram type, ensure that the product works within the defined operating ranges. (→ Page 30)

| Number for the basic diagram | Control system | Number of circuits | Carrying out the wiring |
|------------------------------|---------------------------------|--------------------|----------------------------------------------------------------------|
| 0020253233 | Basic control | 1 | See appendix or contact customer service for special basic diagrams. |
| 0020253235 | VRC 700 system control | 1 | Contact customer service. |
| 0020253236 | Connected vSMART control | 1 | Contact customer service. |



Note

The example of a basic installation diagram that is shown in the appendix does not replace any correct and expert system planning. (→ Page 52)

The settings for the internal pump are made at the factory.

- ▶ Ensure that there is sufficient dimensioning for the connections and the domestic hot water cylinder. (→ Page 15)
- ▶ Connect the external prioritising diverter valve to the plug X13 on the main PCB.
- ▶ In order to control the cylinder's post-heating, connect a **VR 10** temperature sensor or a thermostat to the plug that is connected to the main PCB.
Wiring diagram (→ Page 50)

To start up the prioritising diverter valve, it is not necessary to set a diagnostics code. It is directly actuated by the product's main PCB.

5.1.2 Basic system diagram type 2: Decoupled heating circuit plus one directly connected domestic hot water cylinder

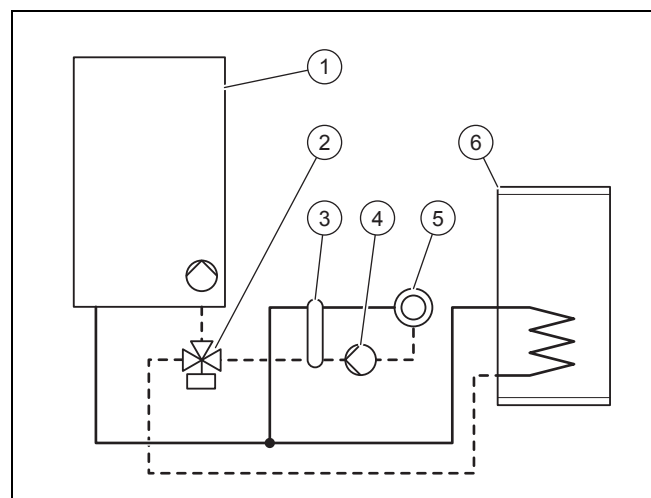

- | | | | |
|---|-----------------------------------------|---|-------------------------------------------------|
| 1 | Wall-hung boiler with internal pump | 4 | External pump for the decoupled heating circuit |
| 2 | Prioritising diverter valve | 5 | Heating circuit |
| 3 | Low loss header or plate heat exchanger | 6 | Domestic hot water cylinder |

- ▶ In order to use this basic diagram type, ensure that the minimum flow volumes are guaranteed for the operation. (→ Page 62)

The product can control a decoupled heating circuit and a directly connected domestic hot water cylinder.

| Number for the basic diagram | Control system | Number of circuits | Carrying out the wiring |
|------------------------------|---------------------------------------------------------|--------------------|--------------------------|
| 0020253238 | VRC 700 system control | 1 | Inform Customer Service. |
| 0020253239 | VRC 700 system control VR 70 multi-functional module | 2 | Inform Customer Service. |
| 0020259027 | VRC 700 system control VR 71 multi-functional module | >3 | Inform Customer Service. |

The settings for the internal pump are made at the factory.

- ▶ Ensure that there is sufficient dimensioning for the connections and the domestic hot water cylinder. (→ Page 15)
- ▶ Downstream of the low loss header, select a heating pump that is appropriate for the installation.
- ▶ Connect the external pump for the decoupled heating circuit to the plug X16 for the main PCB.
- ▶ Connect the external prioritising diverter valve to the plug X13 on the main PCB.
- ▶ Connect the temperature sensor for the low loss header to plug X41 on the main PCB. Observe the instructions for the low loss header.
- ▶ In order to control the cylinder's post-heating, connect a VR 10 temperature sensor or a thermostat to the plug that is connected to the main PCB.
Wiring diagram (→ Page 50)
- ▶ Set diagnostics code **D.026** to 2.
Overview of diagnostics codes (**Applicability:** VU 446/5-5 (H-GB) OR VU 606/5-5 (H-GB)) (→ Page 42)

5.1.3 Basic system diagram type 3: Decoupled heating circuit plus one decoupled domestic hot water cylinder

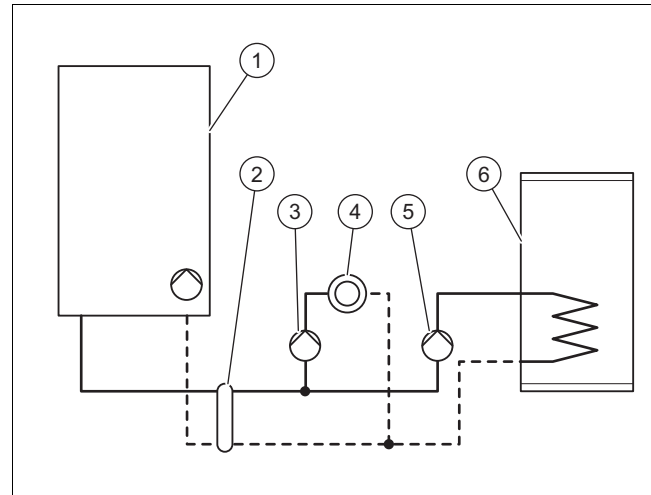

- | | | | |
|---|-------------------------------------------------|---|------------------------------------------------------------|
| 1 | Wall-hung boiler with internal pump | 4 | Heating circuit |
| 2 | Low loss header or plate heat exchanger | 5 | External pump for the decoupled domestic hot water circuit |
| 3 | External pump for the decoupled heating circuit | 6 | Domestic hot water cylinder |

The product can control a decoupled heating circuit and a decoupled domestic hot water cylinder.

| Number for the basic diagram | Control system | Number of circuits | Carrying out the wiring |
|------------------------------|---------------------------------------------------------|--------------------|----------------------------------------------------------------------|
| 0020259029 | VRC 700 system control | 1 | Inform Customer Service. |
| 0020259030 | VRC 700 system control VR 70 multi-functional module | 2 | See appendix or contact customer service for special basic diagrams. |
| 0020259031 | VRC 700 system control VR 71 multi-functional module | >3 | Inform Customer Service. |



Note

The example of a basic installation diagram that is shown in the appendix does not replace any correct and expert system planning. (→ Page 52)

The settings for the internal pump are made at the factory.

- ▶ Ensure that there is sufficient dimensioning for the connections and the domestic hot water cylinder. (→ Page 15)
- ▶ Downstream of the low loss header, select a heating pump that is appropriate for the installation.
- ▶ Downstream of the low loss header, select a domestic hot water pump that is suitable for the domestic hot water cylinder.

5 Installation

- ▶ Connect the external pump for the decoupled heating circuit to the plug X16 for the main PCB.
- ▶ Connect the pump for the decoupled domestic hot water circuit to the plug X13 for the main PCB.
- ▶ Connect the temperature sensor for the low loss header to plug X41 on the main PCB. Observe the instructions for the low loss header.
- ▶ In order to control the cylinder's post-heating, connect a **VR 10** temperature sensor or a thermostat to the plug that is connected to the main PCB.
Wiring diagram (→ Page 50)
- ▶ Set diagnostics code **D.026** to 2.
Overview of diagnostics codes (**Applicability:** VU 446/5-5 (H-GB) OR VU 606/5-5 (H-GB)) (→ Page 42)

5.1.4 Basic system diagram type 4: Cascade with two boilers plus one cylinder that is connected to the boiler

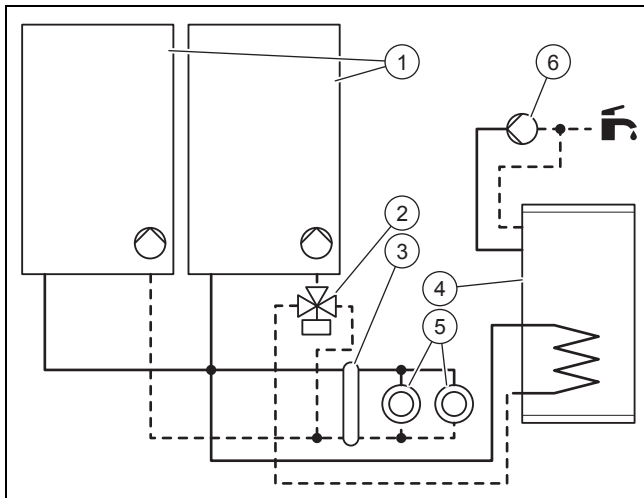

- | | | | |
|---|-----------------------------------------|---|----------------------------------------------|
| 1 | Wall-hung boiler with internal pump | 4 | Domestic hot water cylinder |
| 2 | Prioritising diverter valve | 5 | Heating circuits |
| 3 | Low loss header or plate heat exchanger | 6 | External domestic hot water circulation pump |

The product can control a cascade system.

| Number for the basic diagram | Control system | Number of circuits | Carrying out the wiring |
|------------------------------|-----------------------------------------------------------------------|--------------------|--------------------------|
| 0020259032 | VRC 700 system control VR 70 multi-functional module | 2 | Inform Customer Service. |

The settings for the internal pump are made at the factory.

- ▶ Ensure that there is sufficient dimensioning for the connections and the domestic hot water cylinder. (→ Page 15)
- ▶ Connect the domestic hot water circulation pump to the plug X16 on the main PCB.
- ▶ Connect the external prioritising diverter valve to the plug X13 on the main PCB.
- ▶ Connect the temperature sensor for the low loss header to plug X41 on the main PCB. Observe the instructions for the low loss header.

- ▶ In order to control the cylinder's post-heating, connect a **VR 10** temperature sensor or a thermostat to the plug that is connected to the main PCB.
Wiring diagram (→ Page 50)
- ▶ Set diagnostics code **D.026** to 1.
Overview of diagnostics codes (**Applicability:** VU 446/5-5 (H-GB) OR VU 606/5-5 (H-GB)) (→ Page 42)

5.1.5 Basic system diagram type 5: Cascade with two to seven boilers + a cylinder that is connected to the heating circuit

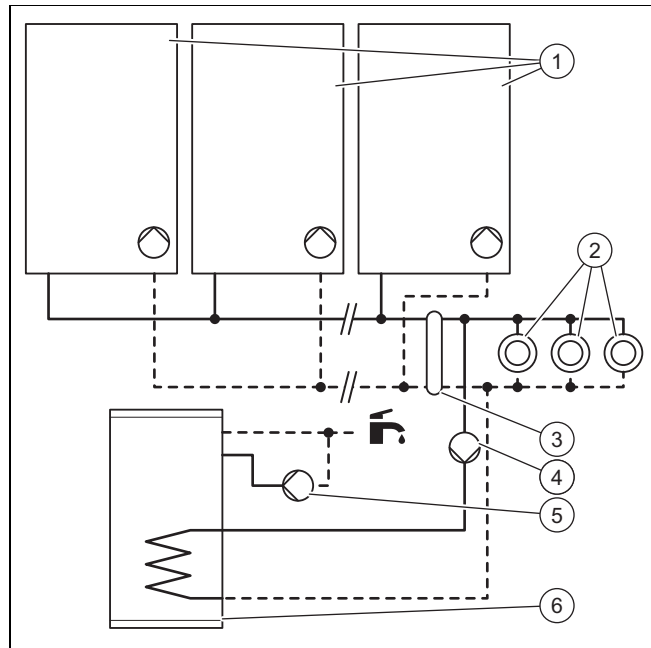

- | | | | |
|---|-----------------------------------------|---|------------------------------------------------------------|
| 1 | Wall-hung boiler with internal pump | 4 | External pump for the decoupled domestic hot water circuit |
| 2 | Heating circuits | 5 | External domestic hot water circulation pump |
| 3 | Low loss header or plate heat exchanger | 6 | Domestic hot water cylinder |

The product can control a cascade system.

| Number for the basic diagram | Control system | Number of circuits | Carrying out the wiring |
|------------------------------|-----------------------------------------------------------------------|--------------------|--------------------------|
| 0020259033 | VRC 700 system control VR 71 multi-functional module | >3 | Inform Customer Service. |

The settings for the internal pump are made at the factory.

- ▶ Ensure that there is sufficient dimensioning for the connections and the domestic hot water cylinder. (→ Page 15)
- ▶ Downstream of the low loss header, select a domestic hot water pump that is suitable for the domestic hot water cylinder.
- ▶ Connect the pump for the decoupled domestic hot water circuit to the plug X13 for the main PCB.
- ▶ Connect the temperature sensor for the low loss header to plug X41 on the main PCB. Observe the instructions for the low loss header.

- ▶ In order to control the cylinder's post-heating, connect a **VR 10** temperature sensor or a thermostat to the plug that is connected to the main PCB.
Wiring diagram (→ Page 50)
- ▶ Set diagnostics code **D.026** to 1.
Overview of diagnostics codes (**Applicability:** VU 446/5-5 (H-GB) OR VU 606/5-5 (H-GB)) (→ Page 42)

5.2 Selecting the domestic hot water cylinder

The product can control an optional domestic hot water cylinder (recommended option for products with an output below 50 kW).

- ▶ Use a low loss header for products that are connected to a domestic hot water cylinder and have a domestic hot water output requirement of over 50 kW, . (→ Page 15)
- ▶ Use the following components to connect the domestic hot water cylinder:

Domestic hot water cylinder

| | Cylinder | Internal diameter of the connection |
|-------------------|-----------|-------------------------------------|
| VU 446/5-5 (H-GB) | VIH R 300 | 20 mm |
| VU 606/5-5 (H-GB) | VIH R 500 | 25 mm |

5.3 Selecting a low loss header

The low loss header disconnects the heat generator hydraulically from the heating system. This prevents feed head interactions between the individual circulation pumps. Furthermore, the low loss header ensures that a sufficient minimum volume of water continuously circulates through the heat generator.

- ▶ Observe the information on treating heating water. (→ Page 21)
 - ▽ If you cannot guarantee the conditions for treating the heating water, install an external plate heat exchanger to protect the product.

Low loss header

| | Heating system spread | | |
|-------------------|-----------------------|---------|---------|
| | 10 K | 15 K | 20 K |
| VU 446/5-5 (H-GB) | WH 95 | WH 40-2 | WH 40-2 |
| VU 606/5-5 (H-GB) | WH 160 | WH 95 | WH 40-2 |

- ▶ Observe the instructions for the low loss header.

You do not require any electronic accessories when using a low loss header. You can connect simple installations directly inside the electronics box.

- ▶ Observe the wiring diagram.
Wiring diagram (→ Page 50)

5.4 Requirements

- ▶ Make sure that the existing gas meter is capable of passing the rate of gas supply required. (→ Page 62)
- ▶ If the hydraulic circuit contains a pump other than the one for the product, only start up the product if a sufficiently dimensioned low loss header is installed between the heat generator circuit and the heating circuit or the cylinder charging circuit.
Low loss header (→ Page 15)
- ▶ If the product's pump is the only circulation pump in the hydraulic circuit, check whether the product's feed head is sufficient for the installation. (→ Page 30)
 - ▽ If this is not the case, use an appropriately designed low loss header and circulation pump.
- ▶ Ensure that the installation has the following components:
 - A gas stopcock for the unit
 - A filling/draining device in the heating installation
- ▶ With older installations in particular, install a magnetic filter at the heating circuit return in order to protect the product against dirt from the installation.
 - Ensure that there is sufficient dimensioning in order to prevent it from blocking quickly and to prevent high pressure losses.

5.4.1 Information on liquid gas operation

In the as-supplied condition, the product is preset for operation with the gas group indicated on the data plate.

Applicability: Except Great Britain

If you have a product that has been preset for operation with natural gas, you must convert it to run on liquid gas. You will need a conversion set for this. The conversion procedure is described in the instructions supplied with the conversion set.

5.4.2 Purging the liquid gas tank

If the liquid gas tank is not purged properly, this may result in ignition problems.

- ▶ Ensure that the liquid gas tank has been purged properly before installing the product.
- ▶ If required, contact the filler or the liquid gas supplier.

5.4.3 Using the correct gas type

Using the incorrect gas type may cause fault shutdowns in the product. Ignition and combustion noise may occur in the product.

- ▶ Only use the gas type listed on the data plate.

5 Installation

5.5 Connecting gas and water



Danger!
Risk of explosion or scalding caused by incorrect installation.

Mechanical stresses in the connection pipes may lead to leaks.

- ▶ Make sure that the connection pipes are free from mechanical stress when they are installed.



Caution.
Risk of material damage due to heat transfer during soldering.

- ▶ Only solder connectors if the connectors are not yet screwed to the service valves.



Caution.
Risk of material damage caused by residues in the pipelines.

Welding remnants, sealing residues, dirt or other residues in the pipelines may damage the product.

- ▶ Flush the heating installation thoroughly before installing the product.



Caution.
Risk of material damage caused by changes to the pipes that have already been connected.

- ▶ Only bend connection pipes if they have not yet been connected to the product.

Seals made of rubber-like materials may be subject to plastic deformation, which can lead to pressure losses.

- ▶ Use fibre seals.

5.5.1 Gas connection



Caution.
Risk of material damage due to the gas leak-tightness test.

At a test pressure of >11 kPa (110 mbar), gas leak-tightness tests may cause damage to the gas valve assembly.

- ▶ If, during gas leak-tightness tests, you also place the gas pipes and the gas valve assembly in the product under pressure, use a max. test pressure of 11 kPa (110 mbar).
- ▶ If you cannot limit the test pressure to 11 kPa (110 mbar), close any gas stopcocks that are installed upstream from the

product before you carry out the gas leak-tightness test.

- ▶ If, during gas leak-tightness tests, you have closed the gas stopcock that is installed upstream of the product, relieve the gas line pressure before you open this gas stopcock.

- ▶ Do not reduce the gas pipe dimension downstream of the gas meter.
- ▶ Maintain the dimension right up to the product.
- ▶ Select the correct gas stopcock.
- ▶ Remove the residues from the gas pipe by blowing through the gas pipe beforehand.

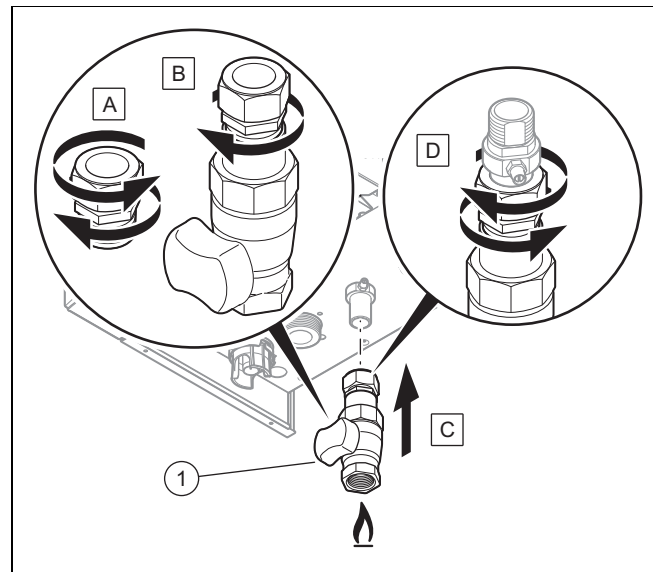

- ▶ If required, use a suitable sealant.
- ▶ Undo the press connection (A).
- ▶ Secure the gas stopcock to the compression fitting (B).
- ▶ Install the unit (1) on the gas pipe at the product's outlet (C) by tightening the compression fitting (D).
- ▶ Install the gas pipe such that it is free from mechanical stress in accordance with the recognised rules of technology.
- ▶ Purge the gas pipe before start-up.

5.5.2 Checking the gas line for leak-tightness

- ▶ Check the entire gas line properly for leak-tightness.

5.5.3 Hydraulic connection



Caution.
Risk of material damage caused by corrosion

Due to non-diffusion-tight plastic pipes in the heating installation, air gets into the heating water. Air in the heating water causes corrosion in the heat generator circuit and in the product.

- ▶ If you use non-diffusion-tight plastic pipes in the heating installation, ensure that no air gets into the heat generator circuit.



Note

In order to keep heat losses to a minimum, we recommend that you provide heat insulation for the water pipe spigots on the product's outlet and on the installation.

- ▶ If you are using plastic pipes in the heating installation, install a safety cut-out in the heating flow.
 - The safety cut-out is required to protect the heating installation against temperature-related damage if a fault occurs.
- ▶ Connect a control or a safety cut-out to the electronics. (→ Page 20)

5.5.3.1 Connecting the heating flow and heating return

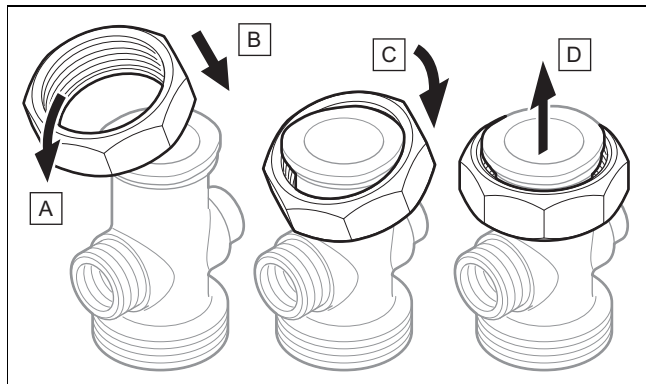

1. Attach the nut to the connection in accordance with steps **(A)** to **(D)**.

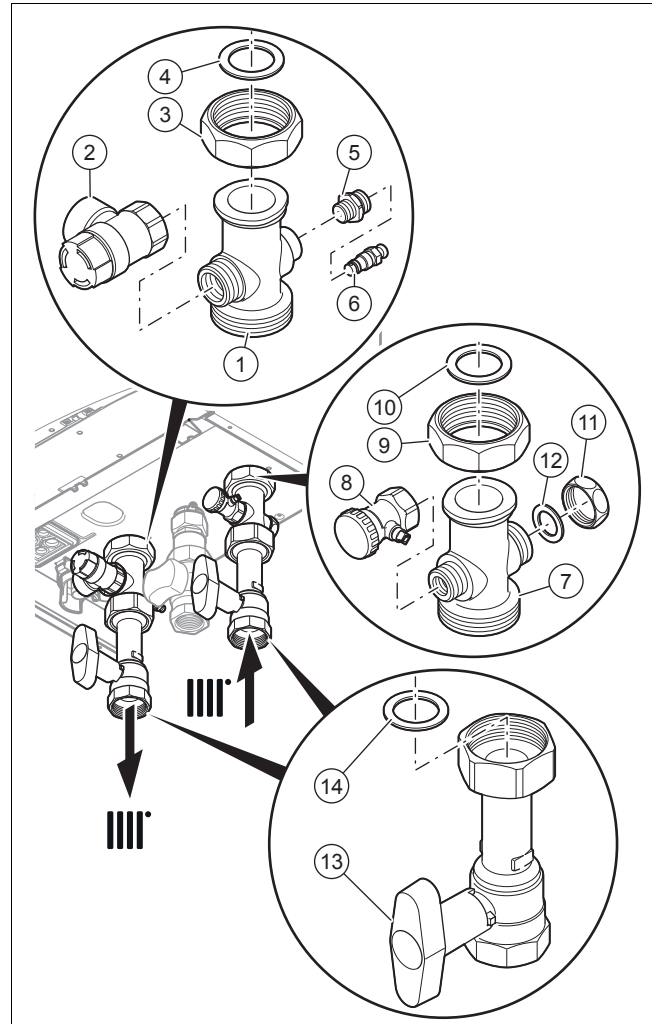

2. Assemble the heating return connection as shown by numbers **(7)** to **(12)**.
3. Assemble the heating flow connection as shown by numbers **(1)** to **(6)**.
4. Insert the seals **(14)**.
5. Install the stopcocks **(13)** at the heating flow and return connection.
6. Connect the heating circuit to the connections for the heating flow and return.
7. Install an expansion vessel in the heating return **(11)**, as close to the product as possible.
 - Ensure that the volumetric capacity of the expansion vessel is sufficient for the system volume.

5.5.4 Connecting the drainage devices



Caution.

Risk of water flowing out below the product

The water drains for the rainwater collecting device and the dynamic air separation system are not connected to the waste-water outflow, but water may escape.

- ▶ Do not place any electrical units or objects that may be damaged by water below the product.

5 Installation

5.5.4.1 Connecting the drain pipework for the expansion relief valve

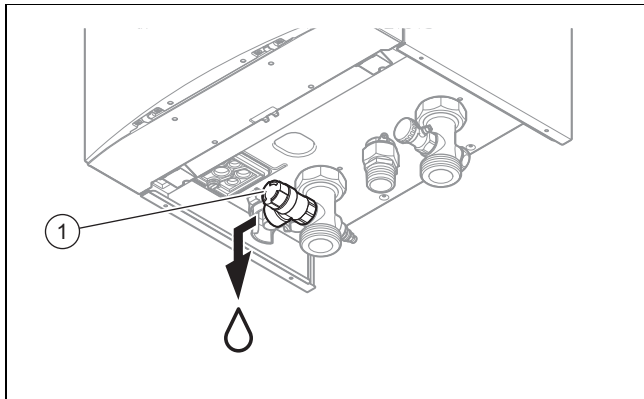

1. Connect the expansion relief valve (1) to a suitable draining circuit. Make sure that the drain hose remains open to the surrounding air.
2. Lay drain pipework for the expansion relief valve that is as short as possible, at a downward gradient.
3. Terminate the drain pipework in such a way that escaping water or steam cannot cause injury to persons or damage to electronic components.
4. Make sure that the line end is visible.

5.5.4.2 Connecting the condensate discharge pipe.

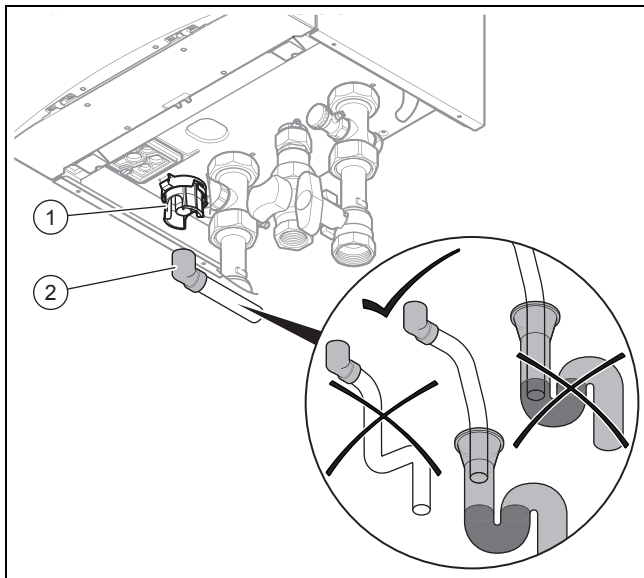

- ▶ Follow the instructions listed here and observe the legal and local regulations on condensate discharge.
- ▶ Use PVC or any other material that is suitable for draining the non-neutralised condensate.
- ▶ If you cannot guarantee that the materials from which the condensate discharge pipe is made are suitable, install a system to neutralise the condensate.



Note

The condensate drain pipework must have a continuous fall (45 mm per metre) and should whenever possible terminate at a suitable drain point within the heated envelope of the building that will remain frost free under long periods of low external temperatures.

- ▶ Ensure that the connection between the condensate discharge pipe and the condensate discharge hose is not air-tight.
- ▶ Connect the condensate siphon (1). Use the supplied condensate discharge hose (2) to do this.
- ▶ Connect a condensate discharge pipe (21.5 mm, not included in the scope of delivery) to the condensate discharge hose (2).
- ▶ During installation remove all burrs from inside of cut pipe work and avoid excessive adhesive which may trap small pockets of water close to the pipe wall which can freeze and build into a larger ice plug.
- ▶ As with other pipe work insulate the condensate discharge pipe to minimise any risk of freezing and beware when crossing cavities that the fall is maintained and the pipe sleeved.

You can find further information in specification "BS 6798" for installing and maintaining gas-fired boilers with a nominal heat input below 70 kW.

5.6 Installing and connecting the air pipe and flue pipe

5.6.1 Installing and connecting the air/flue pipe

1. You can find out which air/flue pipes may be used by consulting the enclosed set-up instructions for the air/flue system.

Condition: Product installed individually in living rooms

- ▶ Observe the information on positioning the opening for the air/flue pipe. This information can be found in the appendix. (→ Page 60) (**Applicability:** Great Britain OR Ireland)

Condition: Product installed in cascade or in business spaces

- ▶ If the product is installed in cascade or in business spaces, observe the requirements for standard IGEM / UP / 10 for the conditions regarding aerating and installing the attachment for the air/flue pipe.
 - <https://www.vaillant.co.uk>

Condition: Installation in damp rooms

- ▶ Connect the product to a room-sealed air/flue system.
 - The combustion air must not be taken from the installation site.



Caution.

Risk of poisoning due to escaping flue gas.

Mineral-oil-based greases can damage the seals.

- ▶ Instead of grease, use only water or commercially available soft soap to aid installation.

2. Install the air/flue pipe using the set-up instructions.

5.6.2 B23 installation

Applicability: Except Great Britain, Except Ireland

A flue system for permitted unit type B23 (atmospheric gas-fired wall-hung boilers) requires careful planning and implementation.

- ▶ Observe the product's technical data when planning.
- ▶ Use the recognised rules of technology.

5.6.3 Installation with flue non-return flap

When installing a flue non-return flap, you must set the minimum output in order to prevent ignition problems.

- ▶ Use diagnostics code **D.085** to set the minimum output. (→ Page 29)

Setting the minimum output of the product

| | D.085 (factory setting) | Setting D.085 for the flue non- return flap |
|-------------------|-------------------------------|---------------------------------------------------|
| VU 446/5-5 (H-GB) | 8 kW | 13 kW |
| VU 606/5-5 (H-GB) | 11 kW | 16 kW |

5.7 Electrical installation



Danger!
Risk of death from electric shock!

Power supply terminals *L* and *N* remain live even if the on/off button is turned off:

- ▶ Switch off the power supply.
- ▶ Secure the power supply against being switched back on again.

Only qualified electricians may carry out the electrical installation.

5.7.1 Opening/closing the electronics box

5.7.1.1 Opening the electronics box

1. Remove the front casing. (→ Page 10)

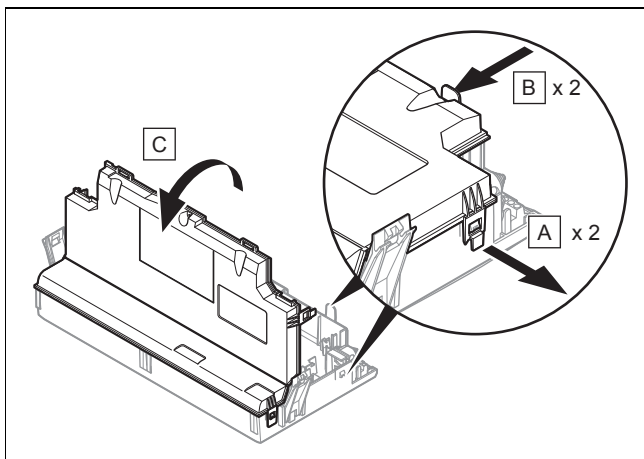

2. Tilt the electronics box forward.
3. Loosen the four clips from the retainers (A) and (B) on the electronics box.
4. Hinge the cover (C) up.

5.7.1.2 Closing the electronics box

1. Close the cover by pushing it downwards onto the electronics box.
2. Ensure that all of the clips audibly click into the retainers.
3. Tilt the electronics box upwards.

5.7.2 Carrying out the wiring



Caution.

Risk of material damage caused by incorrect installation.

Mains voltage at incorrect terminals and plug terminals may destroy the electronics.

- ▶ Do not connect the eBUS terminals (+/-) to the mains voltage.
- ▶ Only connect the power supply cable to the terminals marked for the purpose.

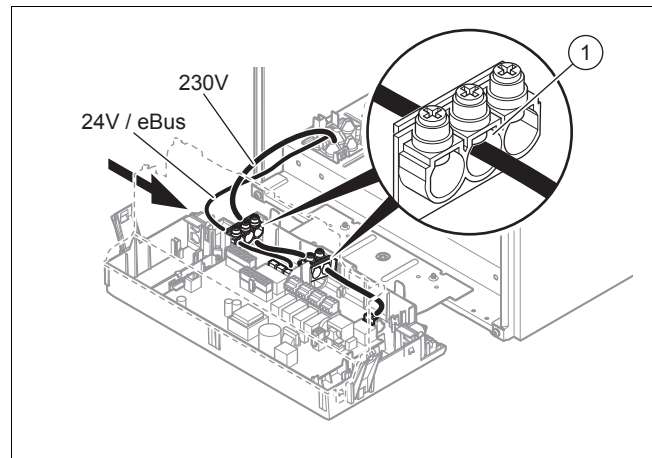

1. Route the connection cables for the components to be connected in the cable trunking on the left of the underside of the product.
2. Use the strain reliefs (1).
3. Shorten the connection cables as necessary.

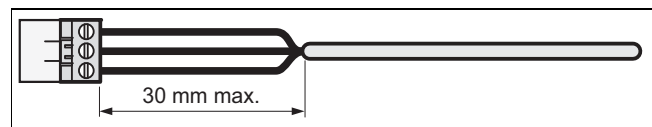

4. Only strip the outer sheathing of flexible lines to a maximum of 30 mm to prevent short circuits if a strand accidentally comes loose.
5. Ensure the inner conductor insulation is not damaged when stripping the outer sheathing.
6. Only strip inner conductors just enough to establish good, sound connections.
7. To avoid short circuits resulting from loose individual wires, fit conductor end sleeves on the stripped ends of the conductors.
8. Screw the plug to the connection cable.
9. Check whether all conductors are properly fastened to the connection terminals of the plug. Remedy this if necessary.
10. Plug the plug into the slot provided on the PCB in accordance with the wiring diagram in the appendix.

5 Installation

5.7.3 Establishing the power supply

1. Provide one common power supply for the boiler and for the corresponding control:
 - Power supply: Single-phase, 230 V, 50 Hz
 - Fuse protection: ≤ 3 A
2. Observe all valid regulations.
 - The applicable regulations state that the connection must be made via an electrical partition with a contact gap of at least 3 mm at each pole.

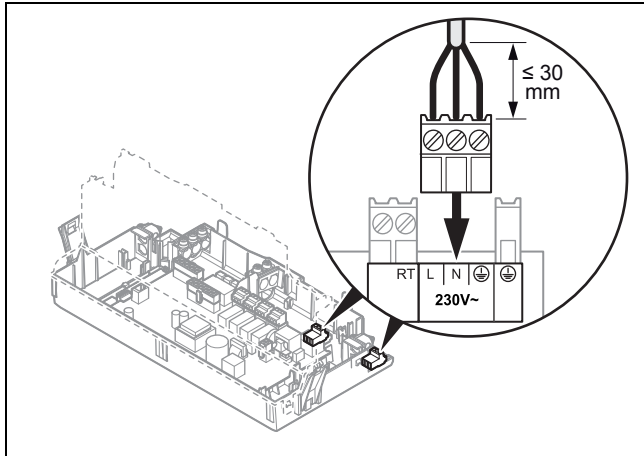

3. Use a flexible line for the power supply cable, which is routed through the grommet into the product.
4. Carry out the wiring. (→ Page 19)
5. Screw the supplied plug to a three-core power supply cable that complies with the relevant standards.
6. Plug the plug for the connection cable into the slot 230V on the main PCB.
7. Close the electronics box. (→ Page 19)
8. Make sure that access to the power supply is always available and is not covered or blocked.

5.7.4 Connecting controls to the electronics

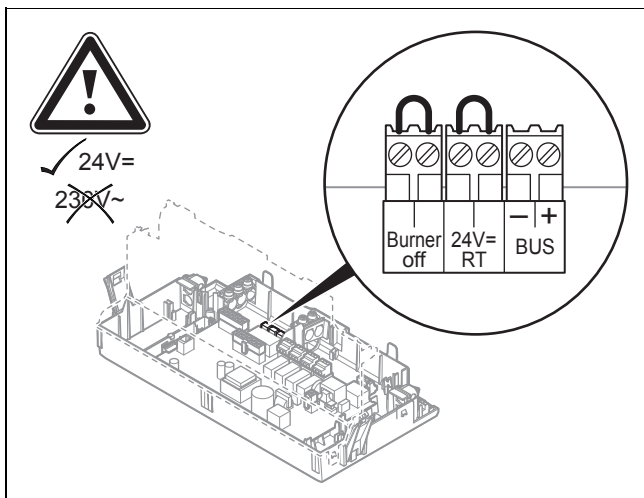

1. Open the electronics box. (→ Page 19)
2. Carry out the wiring. (→ Page 19)
3. **Alternatives 1 – Connecting the weather-compensated eBUS control or eBUS room temperature control:**
 - ▶ Connect the control to the *BUS* plug.
 - ▶ Bridge the *24V=RT* plug if it is not already bridged.

3. **Alternatives 2 – Connecting a 24 V extra low voltage room temperature control:**
 - ▶ Instead of the bridge, connect the control to the 24 V plug.
3. **Alternatives 3 – Connecting limit thermostats for the underfloor heating:**
 - ▶ Connect the limit thermostat to the *Burner off* plug instead of the bridge.
3. **Alternatives 4 – Connecting the 230 V low voltage room temperature control:**

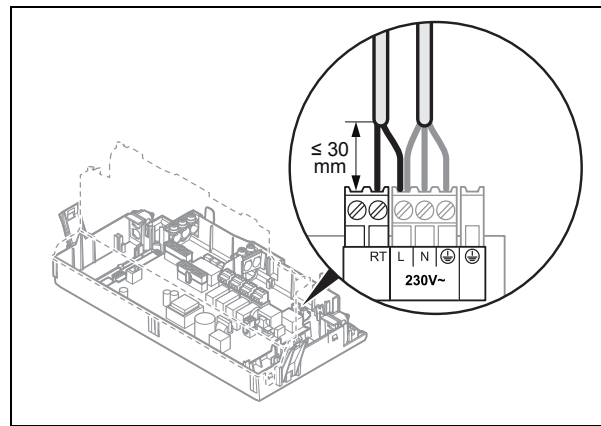

- ▶ Connect the control to the *L* main plug and to the *RT* plug.
 - ▶ Remove the bridge from the *24V=RT* plug.
4. Close the electronics box.
 5. To trigger the **Comfort** pump operating mode (pump runs permanently) using a multi-circuit control, change the diagnostics code **D.018** pump operating mode from **Eco** (pump runs intermittently) to **Comfort**. (→ Page 30)

5.7.5 Connecting the hydraulic accessory

- ▶ Connect the hydraulic accessory in accordance with the selected basic system diagram. (→ Page 12)

5.7.6 Connecting additional components

You can use the integrated additional relay to actuate an additional component.

You can use the optional multi-functional module to actuate two further additional components.

5.7.6.1 Using the additional relay

1. Connect an additional component directly to the integrated additional relay using the grey plug on the PCB.
2. Carry out the wiring. (→ Page 19)
3. Select **D.026** to actuate the connected component. (→ Page 29)

5.7.6.2 Using the VR 40 (2 in 7 multi-functional module)

1. Install the components in accordance with the respective instructions.
2. Select **D.027** to actuate relay 1 on the multi-functional module. (→ Page 29)
3. Select **D.028** to actuate relay 2 on the multi-functional module. (→ Page 29)

6 Operation

6.1 Operating concept

The operating concept and the display and setting options of the end user level are described in the operating instructions.

6.2 Calling up the installer level



Caution.

Risk of material damage caused by incorrect handling.







Incorrect settings at installer level may cause damage and operating faults to the heating installation.

- ▶ You must only access the installer level if you are an approved competent person.



Note

The installer level is protected against unauthorised access using an access code.

1. Press the  and  ("i") buttons at the same time.
 - ◀ The following menu appears in the display.
2. Use the  or  button to scroll until the **Installer level** menu item appears.
3. Confirm by pressing (**OK**).
 - ◀ The text **Enter code** and the value 00 appear in the display.
4. Use  or  to set the value 17 (access code).
5. Confirm by pressing (**OK**).
 - ◀ The installer level appears with a selection of menu items.

6.3 Live Monitor (status codes)

Menu → Live monitor

Status codes in the display provide information on the product's current operating mode.

Status codes – Overview (→ Page 45)

6.4 Calling up appliance config. and diagnostics menu

To recheck and reset the most important system parameters, call up the **Appliance config.** menu item.

Menu → Installer level → Appliance config.

The setting options for more complex installations can be found in the **Diagnostics menu**.

Menu → Installer level → Diagnostics menu

Overview of diagnostics codes (**Applicability:** VU 446/5-5 (H-GB) OR VU 606/5-5 (H-GB)) (→ Page 42)

6.5 Using test programmes

As well as the installation assistants, you can also call up the test programmes for start-up, service and troubleshooting.

Menu → Installer level → Test programs

In addition to the **Function menu**, the product comprises an **Electronics self-test** but also **Check programs** (→ Page 25).

7 Start-up

7.1 Carrying out the initial start-up

Applicability: Great Britain

OR Ireland

Initial start-up must be carried out by a customer service technician or an authorised competent person using the commissioning checklist. The commissioning checklist in the appendix (→ Page 56) (**Applicability:** Great Britain) of the installation instructions must be filled in and stored carefully along with the unit's documentation.

- ▶ Carry out the start-up procedure using the commissioning checklist in the appendix.
- ▶ Fill in and sign the commissioning checklist.

7.2 Checking and treating the heating water/filling and supplementary water



Caution.

Risk of material damage due to poor-quality heating water

- ▶ Ensure that the heating water is of sufficient quality.

- ▶ Before filling or topping up the installation, check the quality of the heating water.

Checking the quality of the heating water

- ▶ Remove a little water from the heating circuit.
- ▶ Check the appearance of the heating water.
- ▶ If you ascertain that it contains sedimentary materials, you must desludge the installation.
- ▶ Use a magnetic rod to check whether it contains magnetite (iron oxide).
- ▶ If you ascertain that it contains magnetite, clean the installation and apply suitable corrosion-protection measures, or fit a magnetic filter.

7 Start-up

- ▶ Check the pH value of the removed water at 25 °C.
- ▶ If the value is below 8.2 or above 10.0, clean the installation and treat the heating water.
- ▶ Ensure that oxygen cannot get into the heating water.

Checking the filling and supplementary water

- ▶ Before filling the installation, measure the hardness of the filling and supplementary water.

Treating the filling and supplementary water

- ▶ Observe all applicable national regulations and technical standards when treating the filling and supplementary water.

Provided the national regulations and technical standards do not stipulate more stringent requirements, the following applies:

You must treat the heating water in the following cases:

- If the entire filling and supplementary water quantity during the operating life of the system exceeds three times the nominal volume of the heating installation, or
- If the guideline values listed in the following table are not met, or
- If the pH value of the heating water is less than 8.2 or more than 10.0.

Applicability: New Zealand

| Total heating output | Water hardness at specific system volume ¹⁾ | | | | | |
|----------------------|--------------------------------------------------------|--------------------|------------------------|--------------------|-----------|--------------------|
| | ≤ 20 l/kW | | > 20 l/kW ≤ 50 l/kW | | > 50 l/kW | |
| kW | °dH | mol/m ³ | °dH | mol/m ³ | °dH | mol/m ³ |
| < 50 | < 16.8 | < 3 | 11.2 | 2 | 0.11 | 0.02 |
| > 50 to ≤ 200 | 11.2 | 2 | 8.4 | 1.5 | 0.11 | 0.02 |
| > 200 to ≤ 600 | 8.4 | 1.5 | 0.11 | 0.02 | 0.11 | 0.02 |
| > 600 | 0.11 | 0.02 | 0.11 | 0.02 | 0.11 | 0.02 |

1) Nominal capacity in litres/heating output; in the case of multi-boiler systems, the smallest single heating output is to be used.

Applicability: Great Britain

OR Ireland

| Total heating output | Water hardness at specific system volume ¹⁾ | | | | | |
|----------------------|--------------------------------------------------------|--------------------|------------------------|--------------------|-----------------------|--------------------|
| | ≤ 20 l/kW | | > 20 l/kW ≤ 50 l/kW | | > 50 l/kW | |
| kW | ppm CaCO ₃ | mol/m ³ | ppm CaCO ₃ | mol/m ³ | ppm CaCO ₃ | mol/m ³ |
| < 50 | < 300 | < 3 | 200 | 2 | 2 | 0.02 |
| > 50 to ≤ 200 | 200 | 2 | 150 | 1.5 | 2 | 0.02 |
| > 200 to ≤ 600 | 150 | 1.5 | 2 | 0.02 | 2 | 0.02 |
| > 600 | 2 | 0.02 | 2 | 0.02 | 2 | 0.02 |

1) Nominal capacity in litres/heating output; in the case of multi-boiler systems, the smallest single heating output is to be used.

Applicability: Great Britain

OR Ireland

OR New Zealand



Caution.

Risk of material damage if the heating water is treated with unsuitable additives.

Unsuitable additives may cause changes in the components, noises in heating mode and possibly subsequent damage.

- ▶ Do not use any unsuitable antifreeze and corrosion inhibitors, biocides or sealants.

No incompatibility with our products has been detected to date with proper use of the following additives.

- ▶ When using additives, follow the manufacturer's instructions without exception.

We accept no liability for the compatibility of any additive or its effectiveness in the rest of the heating system.

Additives for cleaning measures (subsequent flushing required)

- Adey MC3+
- Adey MC5
- Fernox F3
- Sentinel X 300
- Sentinel X 400

Additives intended to remain permanently in the installation

- Adey MC1+
- Fernox F1
- Fernox F2
- Sentinel X 100
- Sentinel X 200

Additives for frost protection intended to remain permanently in the installation

- Adey MC ZERO
- Fernox Antifreeze Alphi 11
- Sentinel X 500

- ▶ If you have used the above-mentioned additives, inform the end user about the measures that are required.
- ▶ Inform the end user about the measures required for frost protection.

7.3 Filling the condensate siphon

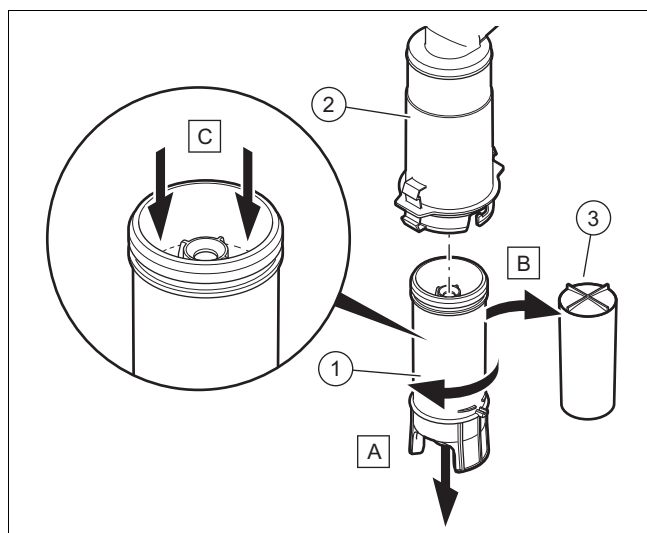

1. Unclip the lower section of the siphon (1) from the upper section of the siphon (2) without removing the product's front casing.
2. Remove the float (3).
3. Fill the lower section of the siphon with water up to 10 mm below the upper edge of the condensate discharge pipe.
4. Re-insert the float (3).



Note

Check whether the float is present in the condensate siphon.

5. Clip the lower section of the siphon (1) into the upper section of the siphon (2).

7.4 Filling the heating installation

1. Flush the heating installation thoroughly before filling it.
2. Observe the information on treating heating water. (→ Page 21)
 - ▽ If you cannot guarantee the conditions for treating the heating water, install an external plate heat exchanger to protect the product.

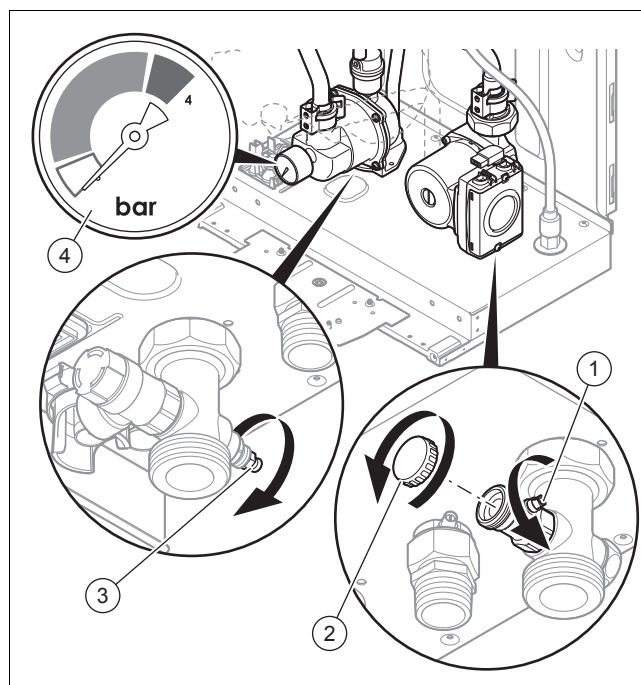

3. Open the plugs (2) and then connect the filling/draining cock connection to a heating water supply in accordance with the relevant standards.
4. Open the heating water supply.
5. Open all thermostatic radiator valves.
6. If necessary, check that both service valves on the product are open.
7. Slowly open the filling/draining cock (1) so that the water flows into the heating installation.
8. Open the air separator (3) and wait until the water flows out of the air separator without bubbles.
9. Purge all of the radiators until the entire heating installation is filled with water.
10. Close all purging valves.
11. Use the manometer (4) to monitor the rising filling pressure in the heating installation.
 - To optimise the purging, the pressure should be limited in such a way that it lies in the first third of the grey display field on the manometer. Once the purging procedure is complete, the digital manometer can be used to set the hydraulic pressure depending on the distribution network (required feed head, multilevel installation, etc.).
12. Fill it with water until the required filling pressure is reached.

Filling pressure

| | Recommended filling pressure | Maximum filling pressure |
|--------------------------|------------------------------------------|----------------------------|
| VU 446/5-5 (H-GB) | 0.15 ... 0.25 MPa (1.50 ... 2.50 bar) | < 0.40 MPa (< 4.00 bar) |
| VU 606/5-5 (H-GB) | 0.15 ... 0.25 MPa (1.50 ... 2.50 bar) | < 0.40 MPa (< 4.00 bar) |

13. Close the filling/draining cock and the heating water supply.
14. Check all of the connections and the entire circuit for leaks.

7 Start-up

7.5 Starting up the product

- ▶ Press the product's on/off button.
 - ◀ The basic display appears on the display.

7.6 Running the installation assistants





The installation assistant is displayed whenever the product is switched on until it has been successfully completed. It provides direct access to the most important check programmes and configuration settings for starting up the product.

- ▶ Confirm the launch of the installation assistant.
 - ◀ All heating demands are blocked whilst the installation assistant is active.
- ▶ To access the next item, confirm by pressing **Next** in each case.
 - ▽ If you do not confirm the launch of the installation assistant, it is closed 10 seconds after you switch on the unit and the basic display then appears.

7.6.1 Language

- ▶ Set the required language.
- ▶ Press **OK** twice to confirm the set language and to avoid unintentionally changing it.

If you have unintentionally set a language that you do not understand, proceed as follows to change it:

- ▶ Press and hold the  and  buttons at the same time.
- ▶ Also press the reset button for a short time.
- ▶ Press and hold  and  until the display shows the language setting option.
- ▶ Select the required language.
- ▶ Press **OK** twice to confirm this change.

7.6.2 Filling the heating circuit

This function is displayed but it is not yet active for this product type.

7.6.3 Purging the heating installation

Purging (corresponds to check programme **P.00**) is activated automatically by the installation assistant and remains in the display for as long as the purging is active. Without the installation assistant, purging also occurs automatically.

The programme must be carried out once or else the product will not start.

- ▶ If the radiators in the house are equipped with thermostatic valves, ensure that all thermostatic valves are open so that the circuit can be purged effectively.
- ▶ To ensure that the purging takes place correctly, the filling pressure of the heating installation must not fall below the minimum filling pressure.
 - Minimum heating installation filling pressure: 0.08 MPa (0.80 bar)



Note

Check programme **P.00** runs for approx. 6.5 minutes for each circuit.

At the end of the filling procedure, the filling pressure of the heating installation must be at least 0.02 MPa (0.2 bar) above the counter-pressure of the expansion vessel ("Exp") ($P_{\text{Installation}} \geq P_{\text{Exp}} + 0.02 \text{ MPa (0.2 bar)}$).

If, at the end of the purge programme, the flow rate that is achieved is insufficient, fault code **F75** appears in conjunction with diagnostics code **D.149 = 8**. The purge programme is considered to have failed and is repeated.

- ▶ Ensure that all of the stopcocks in the hydraulic installation are open.
- ▶ Ensure that the thermostatic valves on the radiators are open.
- ▶ Press the product's reset button to restart an automatic purge programme.
- ▶ Check all connections for tightness.

7.6.4 Setting the target heating temperature

You can use this setting to adjust the required target heating temperature.

7.6.5 Setting the target hot water temperature

This setting is only possible if a domestic hot water cylinder (optional) is installed in the system. This means that the required target hot water temperature can be adjusted (by post-heating the cylinder).

7.6.6 Setting the maximum heating output

The product's maximum heating output can be adjusted to the installation's heat demand. Use diagnostics code **D.000** to set a value that corresponds to the unit output in kW.

7.6.7 Additional relay and multi-functional module

Additional components that are connected to the installation can be adjusted in these menu items. You can use diagnostics codes **D.026**, **D.027** and **D.028** to change the setting.

7.6.8 Telephone: Competent person

You can store your telephone number in the product menu. The end user can view the telephone number. The telephone number can be up to 16 digits long and must not contain any spaces.

7.6.9 Ending the installation assistant

Once the installation assistant has been completed and confirmed, it will not start up automatically next time the unit is switched on.

7.6.10 Restarting the installation assistants

You can restart the installation assistant at any time by calling it up in the menu.

Menu → **Installer level** → **Start inst. assistant**

7.7 Preventing low water pressure

To prevent damage to the heating installation that is caused by low filling pressure, the product is fitted with a water pressure sensor. If the filling pressure falls below 0.1 MPa (1.0 bar), the product indicates low pressure by displaying a flashing pressure value. If the filling pressure falls below 0.05 MPa (0.5 bar), the product switches off. The display shows **F.22**.

- ▶ Top up the heating water to start the product up again.

The pressure value flashes on the display until a pressure of 0.11 MPa (1.1 bar) or higher has been reached.

- ▶ If you notice frequent drops in pressure, determine and eliminate the cause.

The purging function is automatically active after a filling procedure.

7.8 Flushing the heating installation for the first time ("cold")

Applicability: Great Britain

OR Ireland



Note

The complete heating system must be flushed at least twice: Once with cold water and once with hot water in accordance with the following instructions.

1. Check whether all thermostatic radiator valves and both service valves on the product are open.
2. Connect a hose to the drain valve that is located at the lowest position in the heating system.
3. Open the radiator valves and the drain valves so that the water can drain quickly. Start at the next point in the installation and open the purging valves on the radiators so that the contaminated water can completely drain.
4. Close the drain cocks.
5. Refill the heating system with water.
6. Check that the expansion relief valve of the heating system is functioning correctly by turning the handle on the valve.
7. Check the pressure in the heating system and top up with water if necessary.
8. Close the filling valve and the cold water tap.

7.9 Using check programmes

Menu → **Installer level** → **Test programs** → **Check programs**

You can activate various special functions in the product by using various check programmes.

| Display | Meaning |
|---------|---------------------------------------------------------------------------------------------------------------------------------------------------------------------------------------------------------------------------------------------------------------------------------------------------------------------------------------------------------------------------------------------------------------------------------------------------------------------------------------------|
| P.00 | <p>Purging check programme: The internal pump is cyclically actuated. The heating circuit and the domestic hot water circuit are purged via the air separation system.</p> <p>1 x : Start the heating circuit purging 2 x : Start the domestic hot water circuit purging 3 x : Restart the heating circuit purging 1 x (Cancel): End the purge programme</p> <p>Note The purging programme runs for 6.5 minutes per circuit and then terminates.</p> |
| P.01 | <p>Maximum load check programme: After successful ignition, the product is operated at maximum heat input if the flow rate in the heating circuit permits this. Otherwise, the power is reduced in order to adapt to the flow rate.</p> |
| P.02 | <p>Minimum load check programme: After successful ignition, the product is operated at minimum heat input if the flow rate in the heating circuit permits this. Otherwise, the product does not ignite and it remains in waiting mode (status code S.85).</p> |



Note

If the product is in error condition, you cannot start any check programmes. You can detect an error condition by the fault symbol shown in the left bottom corner of the display. You must first reset.

To terminate the check programmes, you can select (**Cancel**) at any time; this does not apply for initial start-up, however. The purging cycle must be completely carried out once so that the burner can ignite.

7.10 Check and gas setting

7.10.1 Checking the factory setting



Caution.

An incorrect gas type setting may cause malfunctions or a reduction in the service life of the product.

If the product design does not match the local gas type, this may lead to malfunctions or to some components wearing prematurely.

- ▶ Before you start up the product, compare the gas type information on the data plate with the gas type group available at the installation site.

The product's combustion has been factory tested and is preset for operation with the gas type indicated on the data plate. In some supply areas, these settings may need to be adjusted at the installation site.

7 Start-up

Condition: The product design is not compatible with the local gas type

- ▶ Do not start up the product.
- ▶ Carry out a gas conversion in accordance with your installation.

Condition: The product design is compatible with the local gas type

- ▶ Proceed as described below.

7.10.2 Checking the leak-tightness of the flue gas installation and flue gas recirculation

Applicability: Great Britain

OR Ireland

1. Check the flue gas installation is intact in accordance with the latest gas safe technical bulletin and information supplied in the installation instructions.
2. For extended flue gas installations check for flue gas recirculation using the air analysis point.
3. Use a flue gas analyser.
4. If you discover CO or CO₂ in the supply air, search for the leak in the flue gas installation or for signs of flue gas recirculation.
5. Eliminate the damage properly.
6. Check again whether the supply air contains any CO or CO₂.
7. If you cannot eliminate the damage, do not start up the product.

7.10.3 Checking the gas flow rate

Applicability: Great Britain

OR Ireland

The boiler is fitted with a multifunctional automatic gas valve which ensures that the precise air/gas ratio is provided under all operating conditions. The gas flow rate has been set during production and does not require adjustment. With the front casing fitted check the gas flow rate of the boiler as follows:

- ▶ Start up the product with the check programme **P.01**.
- ▶ In addition, ensure that maximum heat can be dissipated into the heating system by turning up the room thermostat.
- ▶ Wait at least 5 minutes until the boiler has reached its operating temperature.
- ▶ Ensure that all other gas appliances in the property are turned off.
- ▶ Measure the gas flow rate at the gas meter.
- ▶ Compare the measured values with the corresponding values in the table.

Applicability: VU 446/5-5 (H-GB)

| Qnw from the data plate | H gas in m ³ /h | | | P gas in m ³ /h | | |
|-------------------------|----------------------------|------|------|----------------------------|------|------|
| | Nom. | +5% | -10% | Nom. | +5% | -10% |
| 8.1 | 0.86 | 0.90 | 0.77 | - | - | - |
| 9.5 | - | - | - | 0.39 | 0.41 | 0.35 |
| 26.7 | 2.82 | 2.96 | 2.54 | - | - | - |
| 27.4 | - | - | - | 1.19 | 1.25 | 1.07 |
| 45.2 | 4.78 | 5.02 | 4.30 | 1.85 | 1.94 | 1.67 |

Applicability: VU 606/5-5 (H-GB)

| Qnw from the data plate | H gas in m ³ /h | | | P gas in m ³ /h | | |
|-------------------------|----------------------------|------|------|----------------------------|------|------|
| | Nom. | +5% | -10% | Nom. | +5% | -10% |
| 11.3 | 1.19 | 1.25 | 1.08 | 0.46 | 0.49 | 0.42 |
| 35.7 | 3.77 | 3.96 | 3.39 | 1.46 | 1.53 | 1.31 |
| 60.0 | 6.34 | 6.66 | 5.71 | 2.45 | 2.58 | 2.21 |

Condition: Gas flow rate not in the permissible range

- ▶ Check all of the piping and ensure that the gas flow rates are correct.
- ▶ Only put the product into operation once the gas flow rates have been corrected.

Condition: Gas flow rate in the permissible range

- ▶ End check programme **P.01**.
- ▶ Allow the boiler to cool down by allowing pump overrun to operate for a minimum of two minutes.
- ▶ Record the boiler maximum gas flow rate onto the Benchmark gas boiler commissioning checklist.

7.10.4 Checking the gas flow pressure

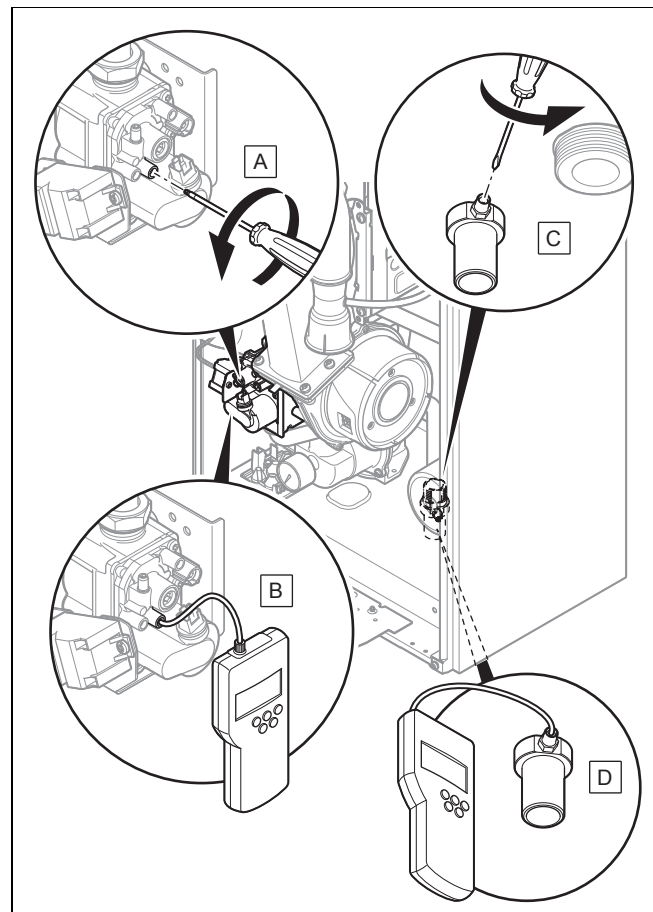

1. Ensure that the gas inlet working pressure can be obtained with all other gas appliances in the property working.
2. Close the gas stopcock.
3. **Alternatives 1 – Measuring the gas pressure at the gas valve assembly::**
 - ▶ Undo the test nipple screw (**A**) on the gas valve assembly.

- ▶ Connect a digital manometer or U-tube manometer (B).
3. **Alternatives 2 – Measuring the gas pressure at the gas connection::**
- ▶ Undo the test nipple screw (C) at the gas connection.
 - ▶ Connect a digital manometer or U-tube manometer (D).
4. Open the gas stopcock.
5. Open the hydraulic circuit's valves.
6. Start up the product with the check programme **P.01**.
7. In addition, ensure that maximum heat can be dissipated into the heating system by turning up the room thermostat.
8. With the boiler operating at full load check that the gas inlet working pressure at the reference test point (1) complies with the requirements.

Gas connection pressure/gas flow pressure difference for G20

| | Permitted gas flow pressure that is measured at point (D) | Permitted gas flow pressure that is measured at point (B) |
|--------------------------|-----------------------------------------------------------|-----------------------------------------------------------|
| VU 446/5-5 (H-GB) | 1.70 ... 2.50 kPa (17.00 ... 25.00 mbar) | 1.60 ... 2.40 kPa (16.00 ... 24.00 mbar) |
| VU 606/5-5 (H-GB) | 1.70 ... 2.50 kPa (17.00 ... 25.00 mbar) | 1.55 ... 2.35 kPa (15.50 ... 23.50 mbar) |

Gas connection pressure/gas flow pressure difference for G31

| | Permitted gas flow pressure that is measured at point (D) | Permitted gas flow pressure that is measured at point (B) |
|--------------------------|-----------------------------------------------------------|-----------------------------------------------------------|
| VU 446/5-5 (H-GB) | 2.50 ... 4.50 kPa (25.00 ... 45.00 mbar) | 2.45 ... 4.45 kPa (24.50 ... 44.50 mbar) |
| VU 606/5-5 (H-GB) | 2.50 ... 4.50 kPa (25.00 ... 45.00 mbar) | 2.35 ... 4.35 kPa (23.50 ... 43.50 mbar) |

9. Should the pressure recorded at the reference test point in the boiler be lower than indicated check if there is any blockage in the pipework or if the pipework is undersized.

Condition: Gas flow pressure not in the permissible range



Caution.

Risk of material damage and operating faults caused by incorrect gas flow pressure.

If the gas flow pressure lies outside the permissible range, this can cause operating faults in and damage to the product.

- ▶ Do not make any adjustments to the product.
- ▶ Check the gas installation.
- ▶ Do not start up the product.

- ▶ If you cannot correct the failure, notify the gas supply company and proceed as follows:
- ▶ End check programme **P.01**.
- ▶ Allow the boiler to cool down by allowing pump overrun to operate for a minimum of two minutes.
- ▶ Close the gas stopcock.
- ▶ Remove the pressure gauge and retighten the sealing screw (A) or (C) for the measuring nipple.
- ▶ Open the gas stopcock.
- ▶ Check the test nipple for gas tightness.
- ▶ Close the gas stopcock.
- ▶ Install the front casing. (→ Page 11)
- ▶ Disconnect the product from the power grid.
- ▶ You must not start up the boiler.

Condition: Gas flow pressure in the permissible range

- ▶ End check programme **P.01**.
- ▶ Allow the boiler to cool down allowing pump overrun to operate for a minimum of two minutes.
- ▶ Close the gas stopcock.
- ▶ Remove the pressure gauge and retighten the sealing screw (A) or (C) for the measuring nipple.
- ▶ Open the gas stopcock.
- ▶ Check the test nipple for gas tightness.
- ▶ Install the front casing. (→ Page 11)
- ▶ Reset boiler controls for normal operation.

Applicability: Great Britain

OR Ireland

- ▶ Record the appliance gas inlet working pressure (kPa resp. mbar) in the Benchmark gas boiler commissioning checklist.

7.10.5 Checking the CO₂ content and, if necessary, adjusting it (air ratio setting)

1. Ensure that the heating circuit valves are open.
2. Start up the product with the check programme **P.01**.
3. Wait at least five minutes until the product reaches its operating temperature.

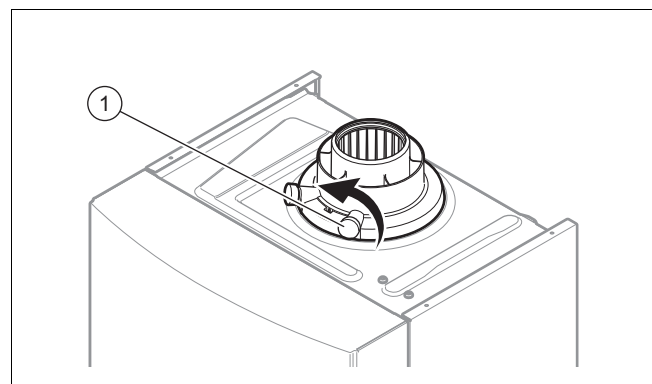

4. Use a combustion analyser to measure the CO₂ content at the flue gas analysis point (1).
5. Compare the measured value with the corresponding value in the table.

7 Start-up

Set values, G20 natural gas (→ Page 61)

Set values, G31 liquefied petroleum gas (→ Page 62)

- Remove the front casing. (→ Page 10)

Applicability: VU 446/5-5 (H-GB)

Condition: The CO₂ content must be adjusted

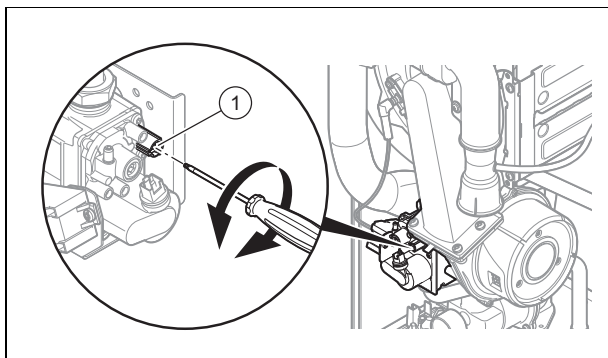

- ▶ Set the CO₂ content (value with front casing removed) by turning the screw (1).
- ▶ Only carry out the adjustment in increments of 1/8 turn and wait approximately 1 minute after each adjustment until the value stabilises.



Note

Turn anti-clockwise: Lower CO₂ content
Turn to clockwise: Higher CO₂ content

Applicability: VU 606/5-5 (H-GB)

Condition: The CO₂ content must be adjusted

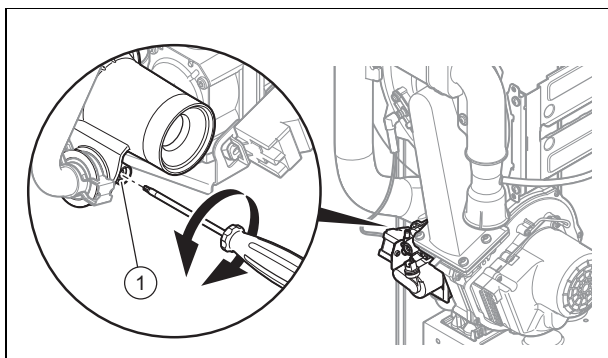

- ▶ Set the CO₂ content (value with front casing removed) by turning the screw (1).
- ▶ Only carry out the adjustment in increments of 1/8 turn and wait approximately 1 minute after each adjustment until the value stabilises.



Note

Turn to the left: Higher CO₂ content
Turn to the right: Lower CO₂ content

- Once the setting is finished, lock the check programme.
- If an adjustment is not possible in the specified adjustment range, do not start up the product.

– Inform Customer Service.

- Install the front casing. (→ Page 11)

7.10.6 Gas conversion procedure



Note

The conversion procedure is described in the instructions that are included with the conversion set that is supplied with the product.

- ▶ Follow the instructions in the manual for the conversion set to carry out the gas conversion on the product.

7.11 Checking leak-tightness

- ▶ Check the gas pipe, the heating circuit and the hot water circuit for leak-tightness.
- ▶ Check that the air/flue pipe has been installed correctly.

Condition: Room-sealed operation

- ▶ Check whether the vacuum chamber has been closed tightly.

7.11.1 Checking the heating mode

- Ensure that there is a heating demand at the product.
- Call up **Live monitor**.
Status codes – Overview (→ Page 45)
 - ◁ If the product is working correctly, the display shows **S.04**.

7.11.2 Checking the hot water generation

Condition: Cylinder connected



Danger!

Risk of death from legionella.

Legionella multiply at temperatures below 60 °C.

- ▶ Ensure that the end user is familiar with all of the Anti-legionella measures in order to comply with the applicable regulations regarding legionella prevention.

- ▶ Make sure that the cylinder thermostat is requesting heat.
- Call up **Live monitor**.
Status codes – Overview (→ Page 45)
 - ◁ If the cylinder charging is carried out correctly, **S.24** appears in the display.
 - If you have connected a control to the installation and you can set the domestic hot water temperature on this control, set the domestic hot water temperature on the boiler to the maximum possible temperature.
 - Adjust the target temperature for the connected domestic hot water cylinder to the control.
 - ◁ The boiler adopts the set target temperature which is set on the control.

7.12 Thoroughly flushing the heating installation ("hot")

Applicability: Great Britain
OR Ireland

1. Operate the appliance until the boiler and the heating system are up to temperature.
2. Check the heating system for leaks.
3. Connect a hose to the drain valve located at the lowest position of the heating system.
4. Shut off the boiler, open the drain valve and all purge valves on the radiators and allow the water to flow out of the heating system and the boiler quickly and fully.
5. Close the drain valve.
6. Fill the heating system again with water as described in "Filling and purging the heating installation" (→ Page 23).
7. Re-fill the system until the system design pressure of 0,1 MPa (1,0 bar) is attained.



Note

The actual reading on the digital pressure gauge should ideally be 0,05 MPa (0,5 bar) plus an additional pressure corresponding to the highest point of the system above the base of the boiler – 10 m head equals an additional 1 bar reading on the pressure gauge. The minimum pressure should not be less than 0,1 MPa (1 bar) in any installation. If the system is to be treated with an inhibitor it should be applied at this stage in accordance with the manufacturer's instructions. See the section on checking and preparing the heating water. (→ Page 21)

8. Install the front casing. (→ Page 11)

8 Adapting the unit to the heating installation

To reset the most important system parameters, call up the **Appliance config.** menu item.

Menu → Installer level → Appliance config.

Or manually relaunch the installation assistant.

Menu → Installer level → Start inst. assistant

8.1 Activating diagnostics codes

The setting options for more complex installations can be found in the diagnostics codes.

Menu → Installer level → Diagnostics menu

You can use the parameters that are marked as adjustable in the overview of diagnostics codes to adapt the product to the heating installation and the needs of the customer.

- ▶ Press or to change the diagnostics code.
- ▶ Press (**Select**) to select the parameter to change.
- ▶ Press or to change the current setting.
- ▶ Confirm by pressing (**OK**).

8.2 Adapting the heating settings

8.2.1 Setting the maximum heating output

The maximum heating output for the product is set to **Auto** at the factory. If you want to set a fixed maximum heat output, you can use diagnostics code **D.000** to define a value that corresponds to the product output in kW.

8.2.2 Setting the burner anti-cycling time

To prevent frequent switching on and off of the burner and thus prevent energy losses, an electronic restart lockout is activated for a specific period each time the burner is switched off. You can adjust the burner anti-cycling time to the conditions of the heating installation. The burner anti-cycling time is only active for the heating mode. Switching on domestic hot water mode during the burner anti-cycling time has no effect. You can use diagnostics code **D.002** to set the maximum burner anti-cycling time (factory setting: 20 min.). The effective burner anti-cycling times with respect to the target flow temperature and the maximum set burner anti-cycling time can be found in the following table:

| T _{Flow} (target) °C | Set maximum burner anti-cycling time min | | | | | | |
|----------------------------------|---------------------------------------------|-----|-----|------|------|------|------|
| | 1 | 5 | 10 | 15 | 20 | 25 | 30 |
| 30 | 2.0 | 4.0 | 8.5 | 12.5 | 16.5 | 20.5 | 25.0 |
| 35 | 2.0 | 4.0 | 7.5 | 11.0 | 15.0 | 18.5 | 22.0 |
| 40 | 2.0 | 3.5 | 6.5 | 10.0 | 13.0 | 16.5 | 19.5 |
| 45 | 2.0 | 3.0 | 6.0 | 8.5 | 11.5 | 14.0 | 17.0 |
| 50 | 2.0 | 3.0 | 5.0 | 7.5 | 9.5 | 12.0 | 14.0 |
| 55 | 2.0 | 2.5 | 4.5 | 6.0 | 8.0 | 10.0 | 11.5 |
| 60 | 2.0 | 2.0 | 3.5 | 5.0 | 6.0 | 7.5 | 9.0 |
| 65 | 2.0 | 1.5 | 2.5 | 3.5 | 4.5 | 5.5 | 6.5 |
| 70 | 2.0 | 1.5 | 2.0 | 2.5 | 2.5 | 3.0 | 3.5 |
| 75 | 2.0 | 1.0 | 1.0 | 1.0 | 1.0 | 1.0 | 1.0 |

| T _{Flow} (target) °C | Set maximum burner anti-cycling time min | | | | | |
|----------------------------------|---------------------------------------------|------|------|------|------|------|
| | 35 | 40 | 45 | 50 | 55 | 60 |
| 30 | 29.0 | 33.0 | 37.0 | 41.0 | 45.0 | 49.5 |
| 35 | 25.5 | 29.5 | 33.0 | 36.5 | 40.5 | 44.0 |
| 40 | 22.5 | 26.0 | 29.0 | 32.0 | 35.5 | 38.5 |
| 45 | 19.5 | 22.5 | 25.0 | 27.5 | 30.5 | 33.0 |
| 50 | 16.5 | 18.5 | 21.0 | 23.5 | 25.5 | 28.0 |
| 55 | 13.5 | 15.0 | 17.0 | 19.0 | 20.5 | 22.5 |
| 60 | 10.5 | 11.5 | 13.0 | 14.5 | 15.5 | 17.0 |
| 65 | 7.0 | 8.0 | 9.0 | 10.0 | 11.0 | 11.5 |
| 70 | 4.0 | 4.5 | 5.0 | 5.5 | 6.0 | 6.5 |
| 75 | 1.0 | 1.0 | 1.0 | 1.0 | 1.0 | 1.0 |



Note

The remaining burner anti-cycling time following a regular shutdown in heating mode can be called up under diagnostics code **D.067**.

8 Adapting the unit to the heating installation

8.2.3 Resetting the remaining burner anti-cycling time

1st option

Menu → Reset anti-cycl. time

The current burner anti-cycling time appears in the display.

- ▶ Confirm the burner anti-cycling time reset by pressing (**Select**).

2nd option

- ▶ Press the reset button.

8.2.4 Setting the pump overrun and pump mode

You can set the pump overrun under **D.001** (factory setting: 5 min.).

You can use diagnostics code **D.018** to set the pump mode **Comfort** or **Eco**.

In the **Comfort** operating mode, the internal pump is switched on when the heating flow temperature is not at **Heating off** (→ Operating instructions) and the heat demand is enabled via an external control.

The **Eco** operating mode (factory setting) is useful for removing residual heat after hot water generation when the heat demand is extremely low and large target temperature spreads exist between the hot water generation and heating mode target values. This prevents living rooms from being under-supplied. If there is a heat demand, the pump is switched on every 25 minutes for 5 minutes once the overrun time has elapsed.

8.2.5 Setting the heating pump

8.2.5.1 Pump mode setting

The product is equipped with a stage-controlled high-efficiency pump. In the automatic operating mode (**D.014** = 0), the pump stage is controlled in such a way that a constantly available pressure is guaranteed. The target values for the available pressure in mbar can be called up via the diagnostics codes:

- **D.122** for the heating circuit
- **D.148** for the domestic hot water circuit

If required, you can manually set the pump mode to five fixed, selectable stages based on the maximum possible output. This switches the speed regulation off.

- ▶ To change the pump output, change **D.014** to the desired value.



Note

If a low loss header is installed in the heating installation, we recommend switching off the speed regulation and setting the pump output to a fixed value.

8.2.5.2 Help when adjusting a heating installation or when checking the flow rate

You can use diagnostics code **D.029** to display the flow rate in real time (in l/min).

By setting the automatic pump mode (**D.014** = 0) and defining a target value for the available pressure (e.g. **D.122** = 200 mbar), it is possible to adjust the balancing valves for the various radiators.

- ▶ To guarantee that the pump operates, set a permanent heat demand (using the control or the room thermostat).
- ▶ Insulate each radiator and/or each radiator group, one after the other.
- ▶ Adjust the balancing valve for the circuit by displaying the flow rate via diagnostics code **D.029** in order to achieve the flow rate that is recommended for the properties of the radiator and/or radiator group.

8.2.5.3 Product pump curve and operating range

Applicability: VU 446/5-5 (H-GB)

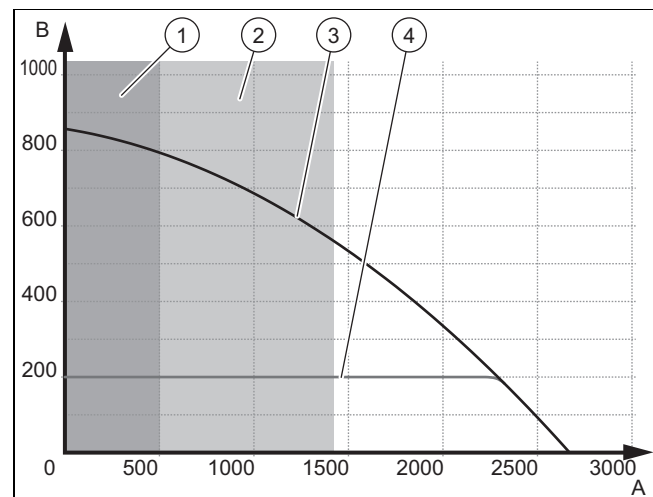

- | | | | |
|---|---------------------------------------------------------|---|-----------------------------------|
| 1 | Flow range without operating the product | 4 | ΔP constant |
| 2 | Operating range with limited flow temperature and power | A | Installation volume flow in l/h |
| 3 | Pump curve at 100% PWM | B | Remaining pump head in hPa (mbar) |

Applicability: VU 606/5-5 (H-GB)

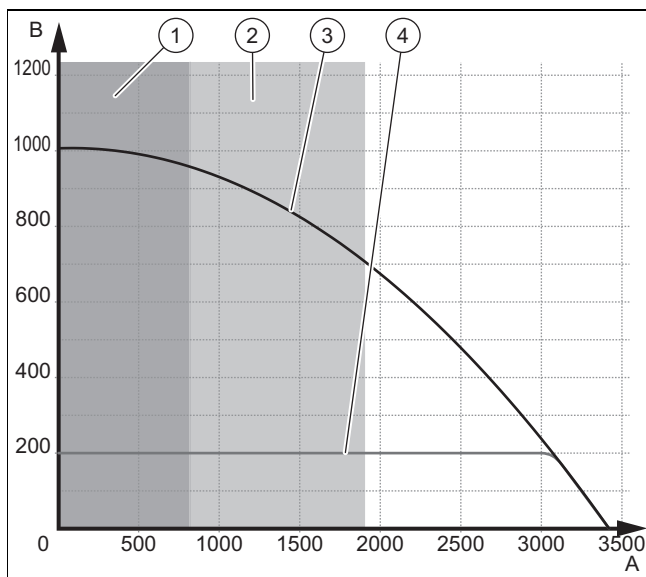

- | | | | |
|---|---------------------------------------------------------|---|-----------------------------------|
| 1 | Flow range without operating the product | 4 | ΔP constant |
| 2 | Operating range with limited flow temperature and power | A | Installation volume flow in l/h |
| 3 | Pump curve at 100% PWM | B | Remaining pump head in hPa (mbar) |

In order to guarantee that the product works without any problems, the flow rate is permanently monitored to determine the operating range.

8.2.6 Setting the maximum flow temperature

You can use diagnostics code **D.071** to set the required maximum flow temperature for the heating mode (factory setting: 75 °C).

8.2.7 Setting the return temperature control

If the product is connected to an underfloor heating system, the temperature control setting can be changed from flow temperature control (factory setting) to return temperature control using diagnostics code **D.017**.

8.3 Setting the maintenance interval

If you set the maintenance interval, after a configurable number of burner operating hours, the message that the product must be serviced appears in the display, together with the maintenance symbol .

- ▶ Use diagnostics code **D.084** to set the operating hours until the next maintenance work is due.

You can set the operating hours in increments of ten from 0 to 3010 h (hours).

If you do not set a numerical value but do set the symbol "-", the function **Maintenance messages** is not active.



Note

On completion of the set operating hours, you must set the maintenance interval again.

9 Handing over to the end user

1. When you have finished the installation, attach the sticker supplied in the end user's language to the front of the product.
2. Explain to the end user how the safety devices work and where they are located.
3. Inform the end user how to handle the product. Answer any questions the end user may have. In particular, draw attention to the safety warnings which the end user must follow.
4. Inform the end user that they must have the product maintained in accordance with the specified intervals.
5. Pass all of the instructions and documentation for the product to the end user for safe-keeping.
6. Instruct the end user about measures taken to ensure the combustion air supply and flue system. Point out, in particular, that the end user must not make any changes, however minor.

10 Troubleshooting

You can find an overview of the fault codes in the appendix.

Fault messages – Overview (→ Page 46)

10.1 Contacting your service partner

If you contact your service partner, if possible, please mention

- The fault code that is displayed (**F.xx**),
- The product status that is displayed (**S.xx**).

10.2 Calling up service messages

If the maintenance symbol  appears in the display, there is a service message that has to be called up.

The maintenance symbol appears if you have set a maintenance interval, for example, and it has elapsed. The product is not in fault mode.

- ▶ To obtain more information about the service message, call up the **Live Monitor**. (→ Page 21)

10.3 Reading off the fault codes

If a fault occurs in the unit or in the system, the display shows an **F.xx** code.

Fault messages – Overview (→ Page 46)

Fault codes have priority over all other displays.

If multiple faults occur at the same time, the display shows the corresponding fault codes for two seconds each in sequence.

- ▶ Eliminate the fault.
- ▶ To restart the product, press the reset button  (Operating instructions).
- ▶ If you are unable to remedy the fault and the fault recurs despite reset attempts, contact customer service.

10 Troubleshooting



10.4 Querying the fault memory

Menu → Installer level → Fault list

The product has a fault memory. You can use this to query the last ten faults that occurred in chronological order.

The display shows:

- Number of faults that occurred
- The fault that is currently selected with fault number **F.xx**
- A plain text display explaining the fault.

- ▶ Use the  or  button to display the last ten faults that occurred.

Fault messages – Overview (→ Page 46)

10.5 Resetting the fault memory

- ▶ To delete the fault memory, press  (**Delete, OK**) twice.

10.6 Performing diagnostics

- ▶ You can use the diagnostics codes during fault diagnostics to change individual parameters or to display further information. (→ Page 29)

10.7 Using check programmes

- ▶ You can also use the check programmes for troubleshooting. (→ Page 25)

10.8 Resetting parameters to factory settings

- ▶ To simultaneously reset all parameters to the factory settings, set diagnostics code **D.096** to 1.

10.9 Replacing defective components

1. Carry out the preparatory work before undertaking any repair work. (→ Page 32)
2. Carry out the work required to finish the task before undertaking any repair work. (→ Page 36)

10.9.1 Procuring spare parts

The original components of the product were also certified by the manufacturer as part of the declaration of conformity. If you use other, non-certified or unauthorised parts during maintenance or repair work, this may void the conformity of the product and it will therefore no longer comply with the applicable standards.

We strongly recommend that you use original spare parts from the manufacturer as this guarantees fault-free and safe operation of the product. To receive information about the available original spare parts, contact the contact address provided on the back page of these instructions.

- ▶ If you require spare parts for maintenance or repair work, use only the spare parts that are permitted for the product.

10.9.2 Preparing the repair work

1. Decommission the product.
2. Disconnect the product from the power grid.

- Take all necessary precautions to ensure that it cannot be switched back on again.

3. Remove the front casing. (→ Page 10)
4. Close the gas stopcock.
5. Close the service valves in the heating flow and in the heating return.
6. Close the service valve in the cold water pipe.
7. Drain the product to replace hydraulic components. (→ Page 40)
8. Ensure that water does not drip on live components (e.g. the electronics box).
9. Use only new seals.

10.9.3 Replacing the burner

1. Remove the compact thermal module. (→ Page 37)

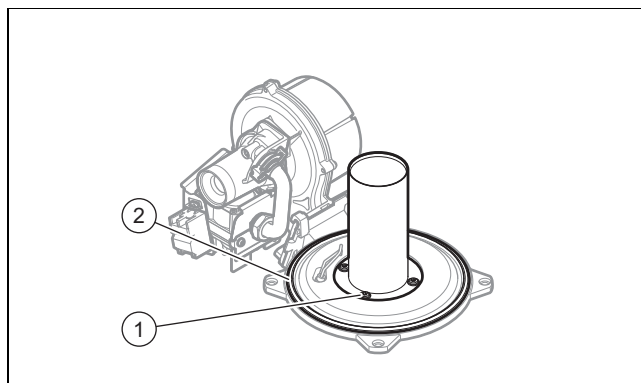

2. Undo the four screws **(1)** on the burner.
3. Remove the burner.
4. Fit the new burner with a new seal.
5. Replace the burner flange seal **(2)**.
6. Install the compact thermal module. (→ Page 38)

10.9.4 Replacing the gas valve assembly, Venturi or fan



Note

Each destroyed seal must be restored.

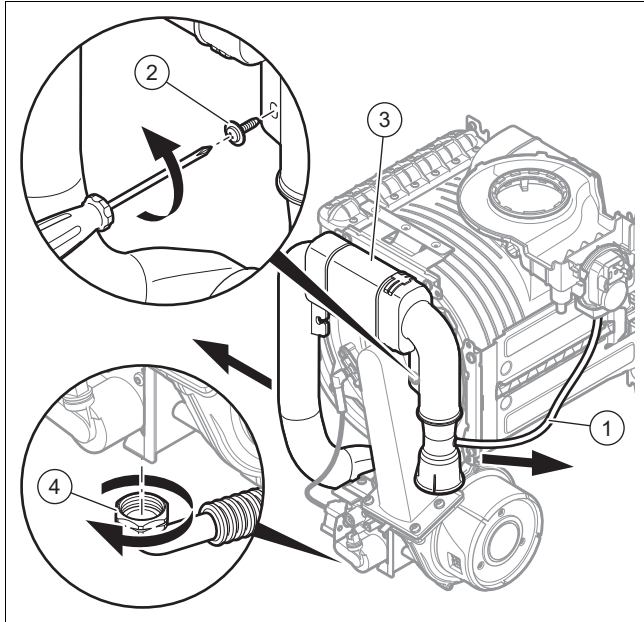

1. Disconnect the test system's silicone pipe for checking the airflow rate (1).
2. Undo the fixing screw (2) and remove the air intake pipe (3) from the intake stub.
3. Unscrew the union nut (4) from the gas valve assembly.

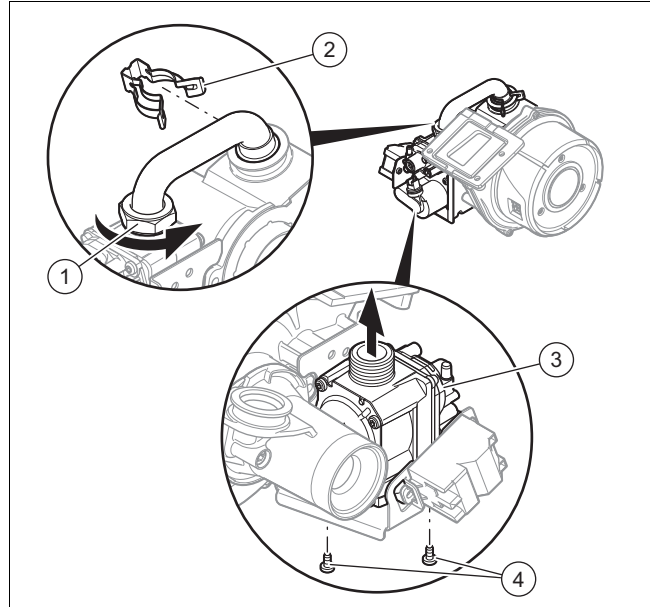

7. Remove the entire unit from the fan, Venturi and gas valve assembly.
8. Undo the nuts (1) on the gas valve assembly.
9. Remove the clip (2).
10. Undo the fixing screws (4) on the gas valve assembly's retainer.
11. Remove the gas valve assembly (3) from the retainer.
12. Replace the gas valve assembly if it is defective.

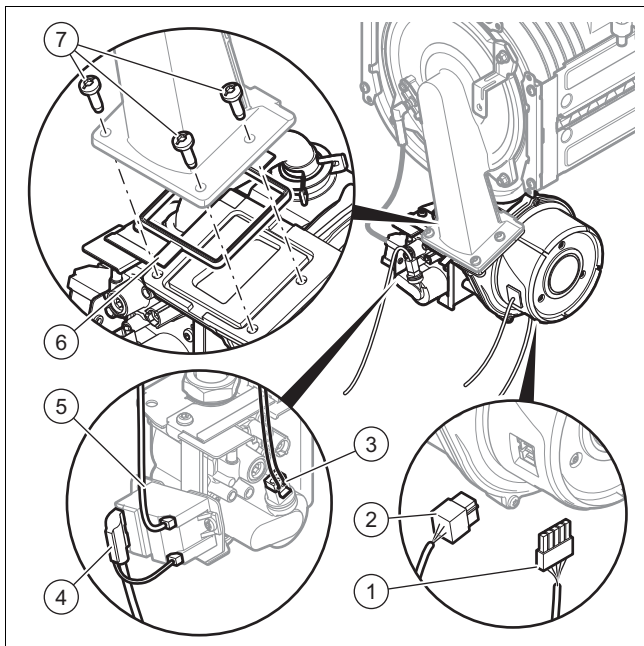

4. Pull out the plugs (1), (2), (3), (4) and (5).
5. Undo the three screws (7) between the mixture pipe and the fan flange.
6. Replace the seal (6).

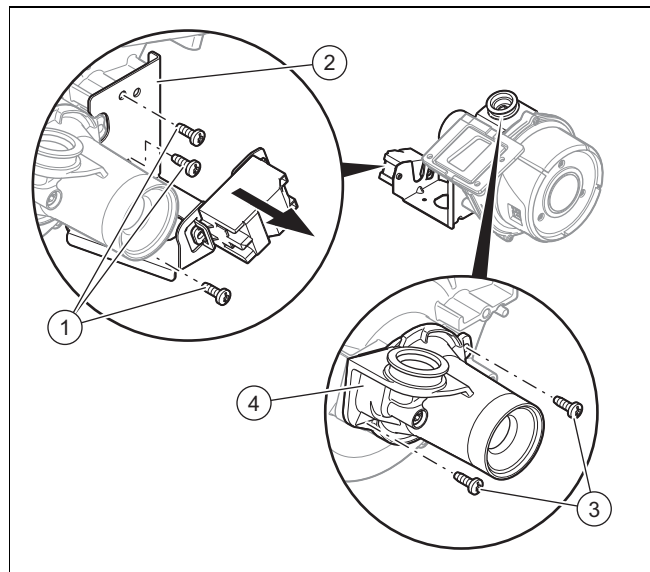

13. Remove the retainer (2) for the gas valve assembly. To do this, undo the three screws (1).
14. Undo the fixing screws (3) for the Venturi.
15. Remove the Venturi (4).
16. Replace the Venturi if it is defective.
17. Replace the fan if it is defective.

10 Troubleshooting

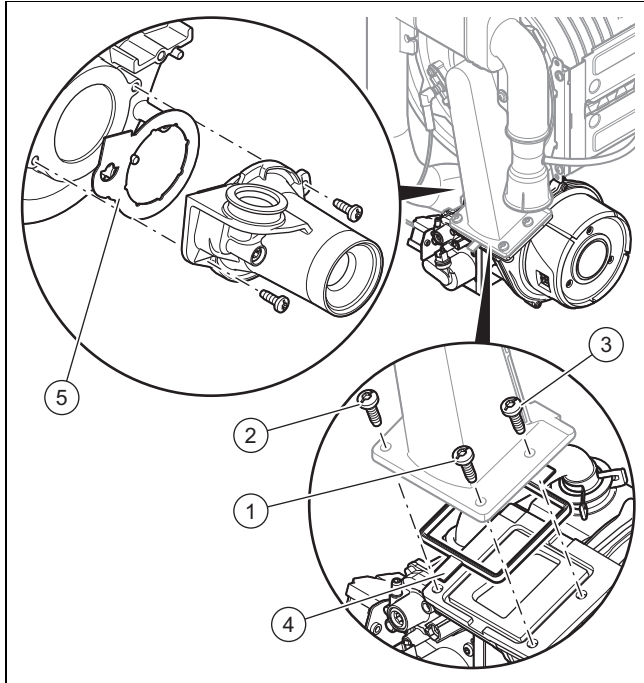

18. Reinstall the components in the reverse order. You must use new seals at position (4) and (5). Follow the tightening sequence for the three screws that connect the fan to the mixture pipe by following the numbering (1), (2) and (3).
19. Screw the gas pipe onto the gas valve assembly. Use new seals for this.
20. Hold on to the gas valve assembly when tightening the union nuts.
21. Once the new components have been installed, carry out the following steps.

Condition: Gas valve assembly

- Carry out a leak-tightness check, check the CO₂ content and adjust this, if required.

Condition: Venturi

- Check the CO₂ content and adjust this, if required.

Condition: Fan

- Check the CO₂ content and adjust this, if required.

10.9.5 Replacing the heat exchanger

1. Remove the adapter for the flue system.
2. Remove the compact thermal module. (→ Page 37)

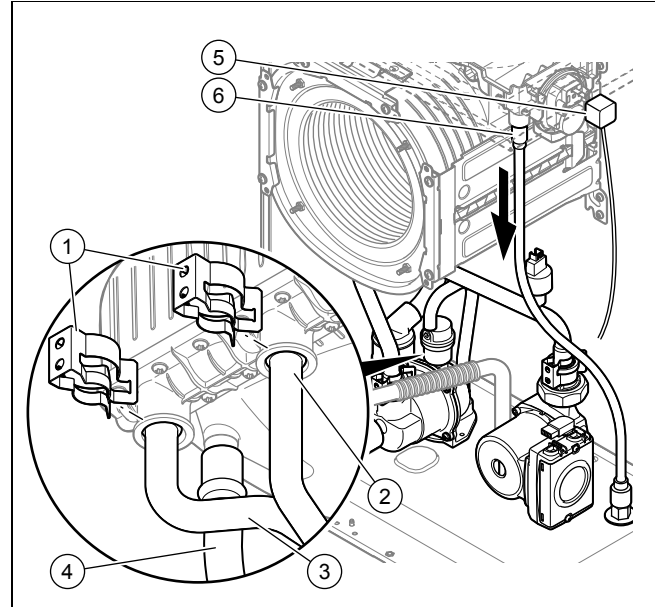

3. Remove the clips (1).
4. Loosen the flow (2) and return pipe (3).
5. Remove the condensate discharge hose (4) from the heat exchanger.
6. Remove the rainwater drain hose (6) from the heat exchanger.
7. Remove the plug (5).

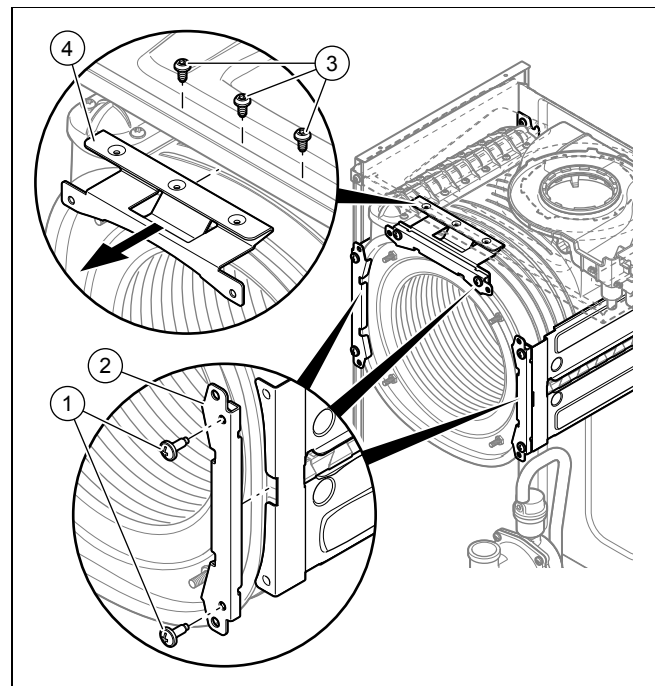

8. Remove the screws (1) and (3).
9. Remove the retainer for the heat exchanger (2) and (4).
10. Pull the heat exchanger downwards and to the right, and remove it from the product.
11. Install the new heat exchanger in reverse order.



Caution.

Risk of poisoning due to escaping flue gas.

Mineral-oil-based greases can damage the seals.

- Instead of grease, use only water or commercially available soft soap to aid installation.

12. Replace the seals.
13. Insert the flow and return pipes into the heat exchanger as far as they will go.
14. Ensure that the clips on the flow and return connection have been attached correctly.
15. Install the compact thermal module. (→ Page 38)
16. Fill and purge the product and, if necessary, the heating installation.

10.9.6 Replace the pressure sensor

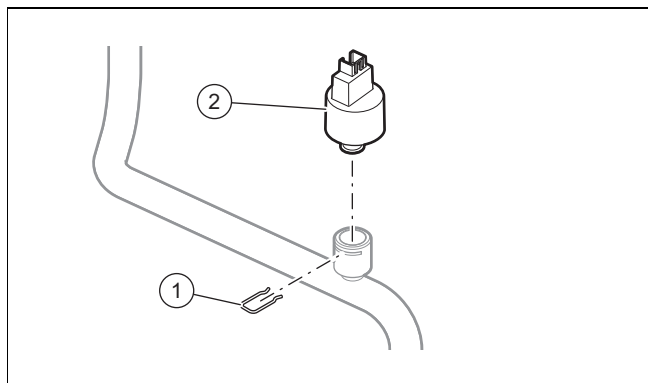

1. Pull out the plug for the pressure sensor.
2. Remove the fastening clip (1).
3. Remove the defective pressure sensor (2).
4. Replace the pressure sensor.
5. Fill and purge the product and, if necessary, the heating installation.

10.9.7 Replacing the heating flow and return temperature sensor

Applicability: VU 446/5-5 (H-GB)

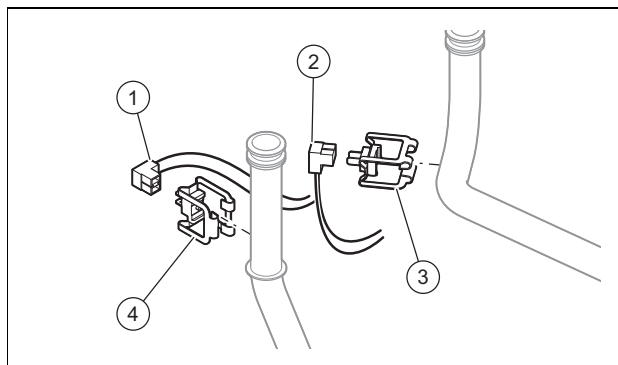

- Pull out the heating flow (4) and return temperature sensor (3).

Applicability: VU 606/5-5 (H-GB)

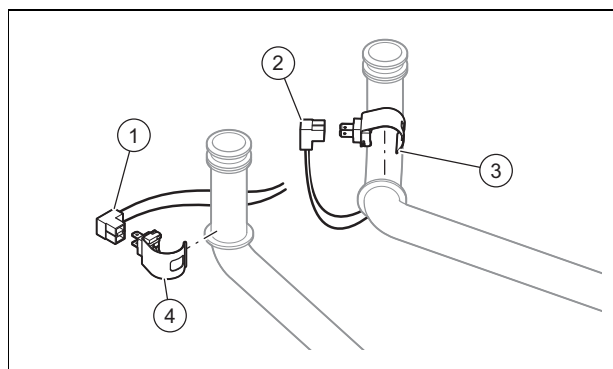

- Pull out the heating flow (4) and return temperature sensor (3).

1. Remove the heating flow (1) and return plug (2).
2. Install the new temperature sensor.
3. When reinstalling, note the colour of the conductors.
 - Blue conductor: Heating return
 - Red conductor: Heating flow

10.9.8 Replacing the pump

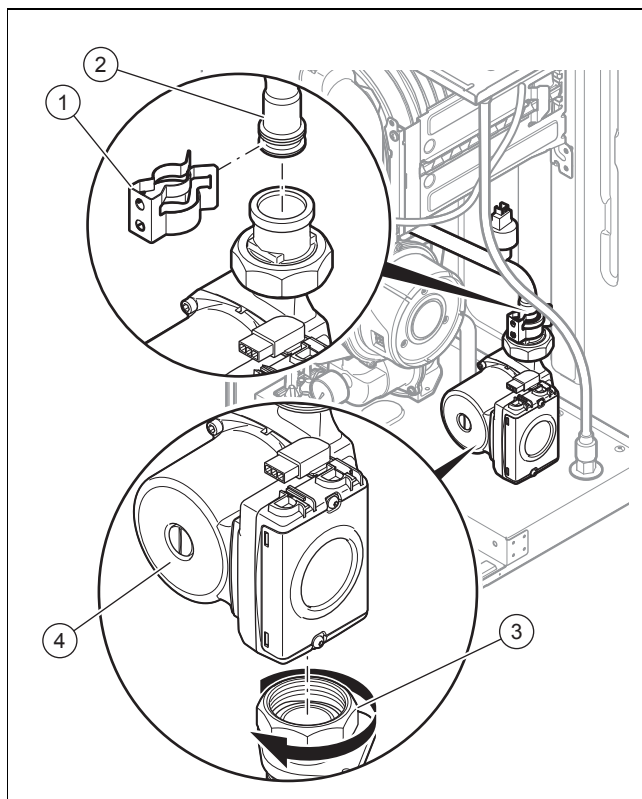

1. Pull out the plug (5) for the pump.
2. Remove the clip (1) from the pipe (2).
3. Detach the connection (3) from below the pump.
4. Remove the defective pump (4).
5. Detach the connection (5) from the pump.
6. Replace the seals.
7. Install the new pump. To do this, proceed in reverse order.

11 Inspection and maintenance

10.9.9 Replace the main PCB and/or the control element's PCB



Caution.
Risk of material damage caused by incorrect repairs.

Using an incorrect PCB may lead to damage to the electronics.

- ▶ Before replacing, check that the correct PCB is available.
- ▶ Never use a different PCB when replacing it.

If you are replacing only one component, the set parameters are transferred automatically. When the product is switched on, the new component adopts the previously set parameters from the unreplaced component.

10.9.9.1 Replacing the main PCB

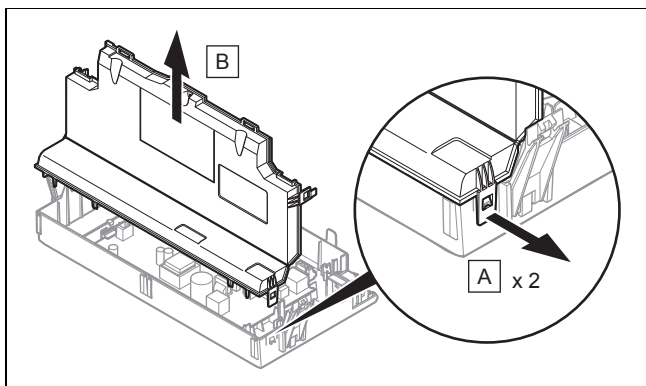

1. Open the electronics box. (→ Page 19)
2. Undo the two clips (**A**) on the electronics box.
3. Remove the cover (**B**) from the electronics box.

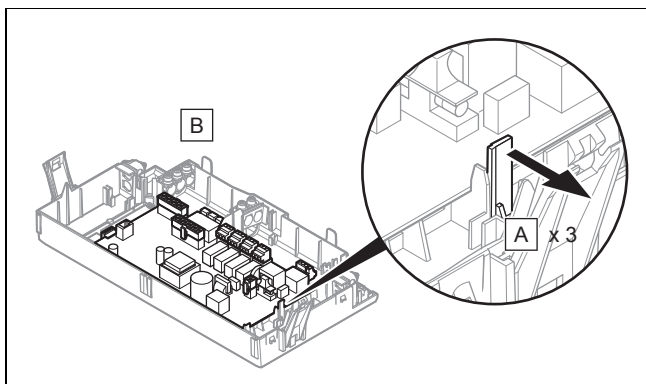

4. Remove the PCB in accordance with the installation instructions that are enclosed with the spare part.
5. Pull all of the plugs out from the PCB.
6. Force the fixing tabs (**A**) apart in order to loosen the PCB.
7. Remove the PCB (**B**).
8. Install the new PCB.
9. Plug the plug into the new PCB.

10.9.9.2 Replacing the PCB for the user interface

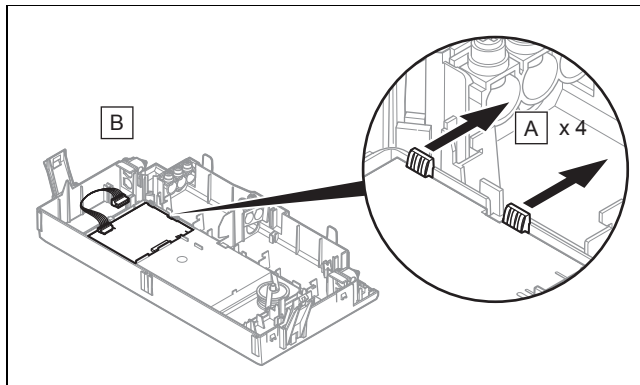

1. Remove the main PCB.
2. Disconnect all of the plugs from the PCB for the user interface.
3. Force the fixing tabs (**A**) apart in order to loosen the PCB for the user interface.
4. Remove the PCB for the user interface (**B**).
5. Install the new PCB for the user interface.
6. Plug the plug into the new PCB for the user interface.
7. Reinstall the main PCB.

10.9.9.3 Replacing the main PCB and control element's PCB at the same time

1. If you are replacing both components at the same time, the product switches directly to the menu to select the language after switching on. The default language setting is English.
2. Select the required language.
3. Press **OK** to confirm this setting.
4. Set the product code **D.093** that is on the data plate.
5. Confirm your setting.
 - ◀ The electronics are now set to the product type (model) and the parameters for all diagnostics codes are set to the default settings.
 - ◀ The display automatically restarts with the installation assistant.
6. Make the system-specific settings.

10.9.10 Completing repair work

1. Open the service valve in the cold water pipe.
2. Open all service valves and the gas stopcock.
3. Check the leak-tightness of the gas pipe and the hydraulic circuits.
4. Install the front casing. (→ Page 11)
5. Switch on the product. (→ Page 24)
6. Check that the product works correctly.
7. Check that the product is leak-tight. (→ Page 28)

11 Inspection and maintenance

- ▶ Comply with the minimum intervals for the inspection and maintenance (Table in the appendix).
- ▶ Carry out maintenance work on the product at an earlier point if the results of the inspection that was carried out during previous maintenance make this necessary.

11.1 Using the function menu

The function menu allows you to actuate and test individual components in the heating installation.

Menu → Installer level → Test programs → Function menu

- ▶ Choose the heating installation components.
- ▶ Confirm by pressing **(Select)**.

| Display | Test programme | Action |
|---------|--------------------------------------------------------|-----------------------------------------------------------------------------------------------|
| T.01 | Check internal pump | The internal heating pump is switched on and off. |
| T.02 | Checking the domestic hot water cylinder charging pump | The domestic hot water cylinder charging pump is switched on and off. |
| T.03 | Check fan | The fan is switched on and off; it runs at maximum speed. |
| T.04 | Not active | |
| T.05 | Domestic hot water circulation pump check | The domestic hot water circulation pump is switched on and off. |
| T.06 | Check external pump | The external heating pump (if present) is switched on and off. |
| T.08 | Checking the burner | Product starts up and switches to minimum load. The flow temperature is shown in the display. |

- ▶ To terminate the function menu, select **(Cancel)**.

11.2 Carrying out electronics self-tests

Menu → Installer level → Test programs → Electronics self-test

The electronic self-test allows for pre-monitoring of the PCBs.

11.3 Cleaning/checking the components

1. Carry out the preparatory work before cleaning/checking any of the components. (→ Page 37)
2. Carry out the work required to finish the task after cleaning/checking any of the components. (→ Page 40)

11.3.1 Preparing the cleaning and inspection work

1. Decommission the product.
2. Disconnect the product from the power grid.
 - Take all necessary precautions to ensure that it cannot be switched back on again.
3. Remove the front casing. (→ Page 10)
4. Close the gas stopcock.
5. Close the service valves in the heating flow and return.
6. Close the service valve in the cold water pipe.
7. Drain the product when you are carrying out work on hydraulic components. (→ Page 40)
8. Ensure that water does not drip on live components (e.g. the electronics box).
9. Use only new seals.

11.3.2 Removing the compact thermal module



Danger!

Risk of death and risk of material damage caused by hot flue gas.

The seal, heat insulation and self-locking nuts on the burner flange must not be damaged. Otherwise, hot flue gases may escape and cause personal injury and material damage.

- ▶ Replace the seal each time you open the burner flange.
- ▶ Replace the self-locking nuts on the burner flange each time you open the burner flange.
- ▶ If the heat insulation on the burner flange or on the back panel of the heat exchanger shows signs of damage, replace the heat insulation.



Note

The compact thermal module consists of five main components:

- Speed-regulated fan,
- Gas valve assembly including support plate,
- Venturi including mass flow sensor and gas connection pipe,
- Burner flange,
- Premix burner.

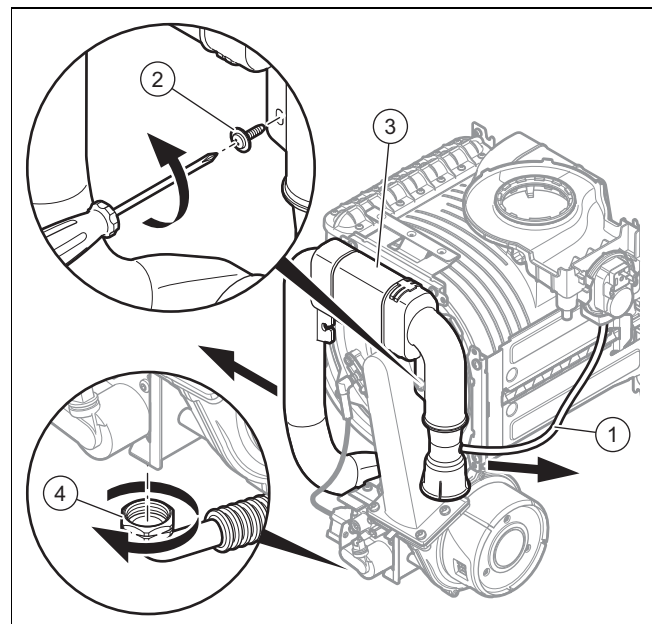

1. Disconnect the test system's silicone pipe for checking the airflow rate **(1)**.
2. Undo the fixing screw **(2)** and remove the air intake pipe **(3)** from the intake stub.
3. Unscrew the union nut **(4)** from the gas valve assembly.

11 Inspection and maintenance

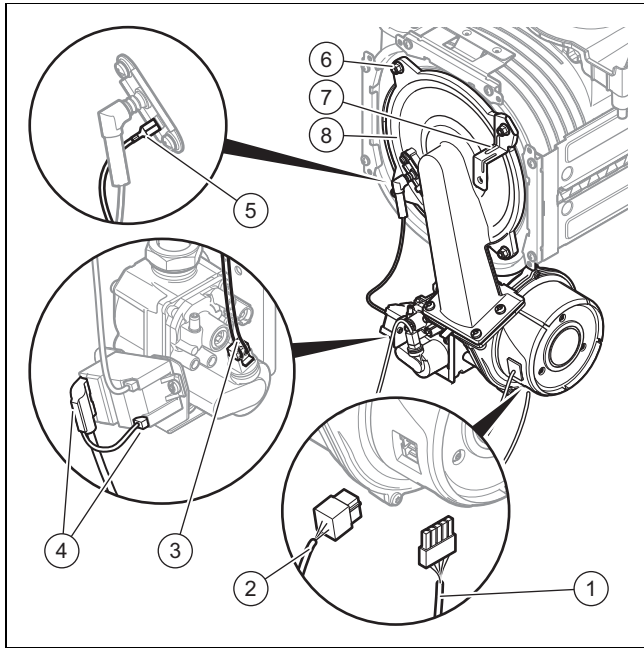

4. Remove the plug for the earth cable (5) from the ignition electrode.
5. Remove the plug (4) from the ignition device.
6. Remove the plugs (1) and (2) from the fan motor by pushing in the latching lug.
7. Remove the plug from the gas valve assembly (3).
8. Unscrew the four nuts (6).
9. Remove the fixing tab (7) for the air intake pipe.
10. Pull the assembly group for the compact thermal module (8) out of the heat exchanger.
11. Check the burner and the heat exchanger for damage and dirt.
12. If necessary, clean or replace the components according to the following sections.
13. Fit a new burner flange seal.
14. Check the insulating mat on the back panel of the heat exchanger.
 - If you notice any signs of damage, replace the insulating mat.
15. Check the insulating material on the burner flange.
 - If you notice any signs of damage, replace the insulating mat.

11.3.3 Cleaning the heat exchanger

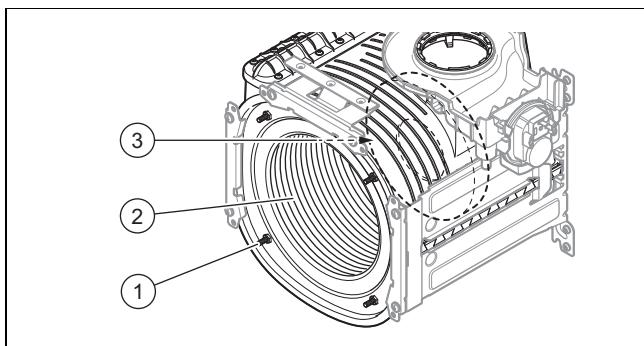

1. Never undo the four nuts on the threaded pin (1) or tighten them.
2. Clean the spiral immersion heater (2) of the heat exchanger using water or, if required, vinegar (up to a

maximum acid content of 5%). Allow the vinegar to act on the heat exchanger for 20 minutes.

3. Use a plastic brush or sufficiently strong jet of water to remove the loosened dirt. In doing so, ensure that no spraying water reaches the other components. Do not point the jet of water directly at the insulating mat (3) on the back of the heat exchanger.
 - ◁ The water flows via the condensate siphon and out of the heat exchanger.
4. Check the insulating mat on the heat exchanger for damage.
 - ▽ Insulating mat is damaged:
 - Replace the insulating mat.

11.3.4 Checking the burner

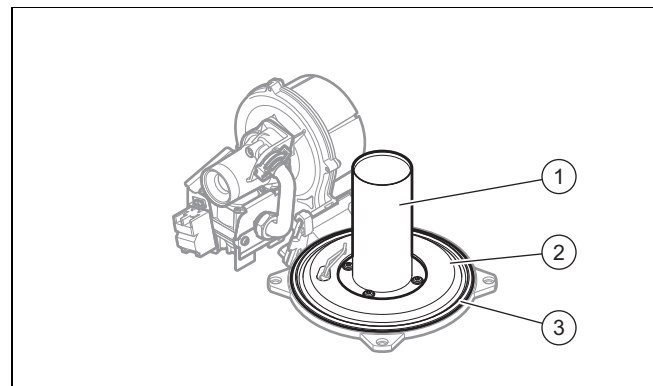

1. Check the surface of the burner (1) for damage. If you see any damage, replace the burner.
2. Check the burner's insulation (2). If required, replace the burner's insulation.
3. Fit a new burner flange seal (3).

11.3.5 Installing the compact thermal module

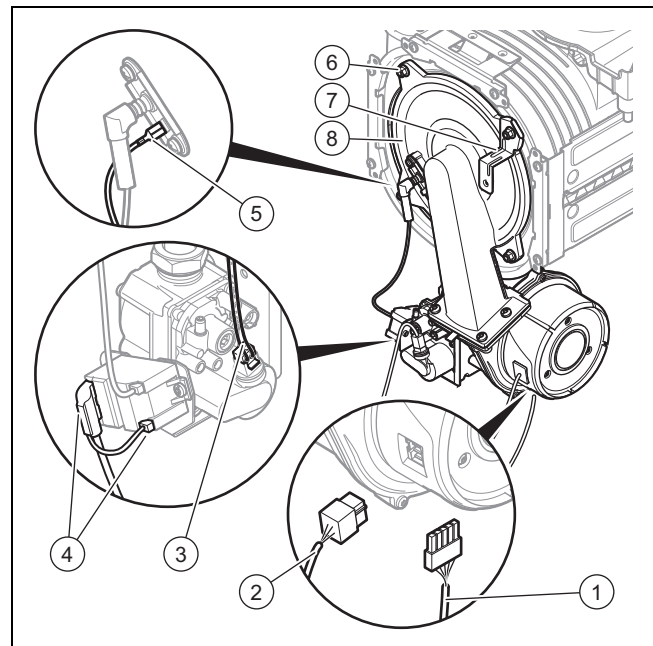

1. Fit the compact thermal module (8) onto the heat exchanger.
2. Attach the fixing tab (7) for the air intake pipe.
3. Tighten the four new nuts (6) across the diagonal until the burner flange fits closely and uniformly onto the mating surfaces.

- Tightening torque: 6 Nm
- 4. Reconnect the plugs (1), (2), (3), (4) and (5).

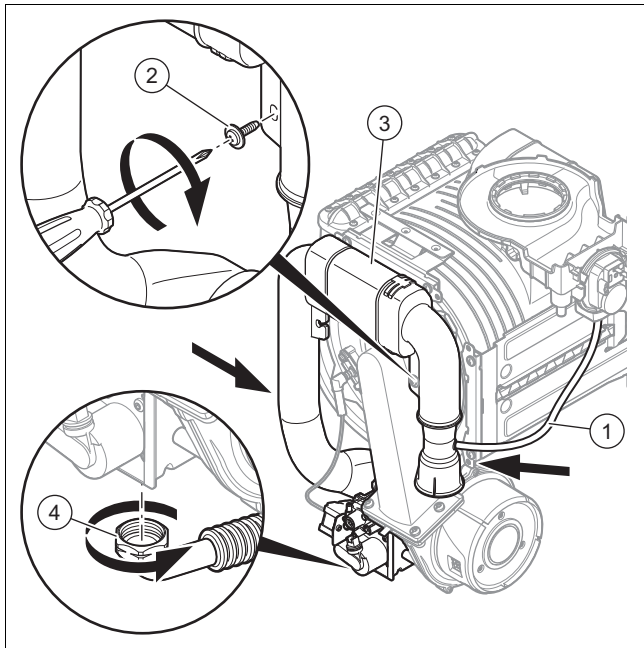

5. Connect the gas pipe (4) using a new seal.
6. Open the gas stopcock.
7. Make sure that there are no leaks.
8. Check that the sealing ring in the air intake pipe (3) is positioned correctly in the seal seat.
9. Reconnect the air intake pipe to the intake stub.
10. Secure the air intake pipe using the retaining screw (2).
11. Reconnect the test system's silicone pipe for checking the airflow rate (1).

11.3.6 Checking the ignition electrode

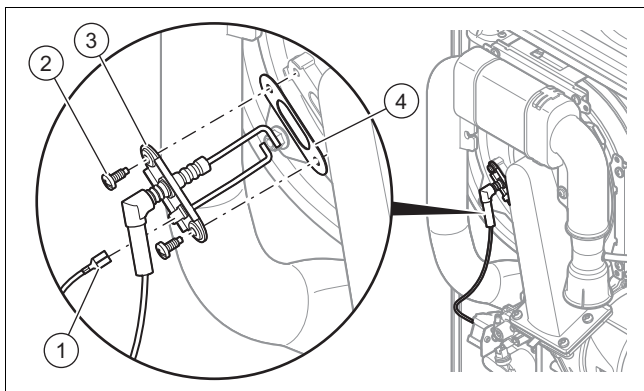

1. Disconnect the earth cable (1).
2. Remove the fixing screws (2).
3. Carefully remove the electrode (3) from the combustion chamber.
4. Ensure that the electrode ends are undamaged.
5. Clean and check the gap between the electrodes.
 - Clearance for the ignition electrodes: 4.5 ± 0.5 mm
6. Replace the seal (4).
7. Install the electrode. To do this, proceed in reverse order.

11.3.7 Cleaning the rainwater collector's draining circuit

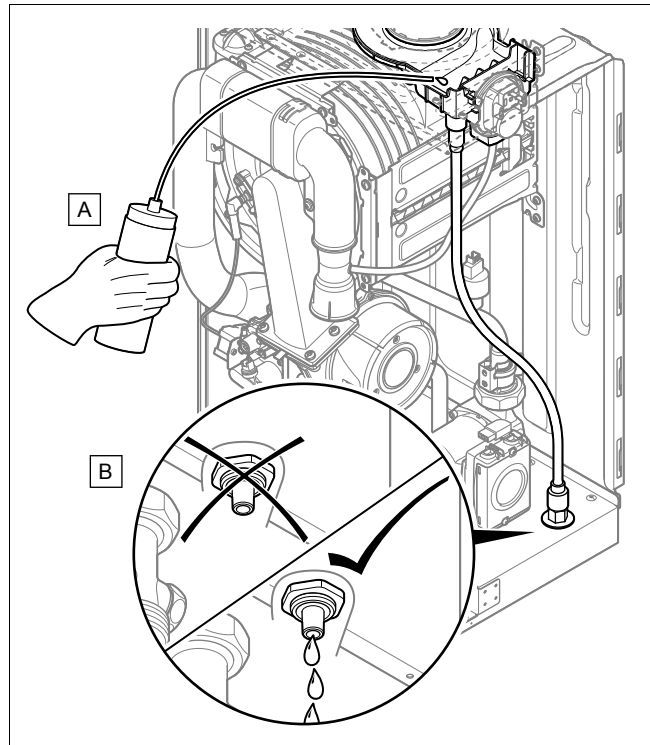

1. Ensure that the rainwater collector is not dirty or blocked and, if required, clean it.
2. Pour water into the rainwater collector (A).
3. Check whether the water drains correctly via the drain (B).
 - ▽ If the water does not drain correctly, clear out the draining circuit.

11.3.8 Cleaning the condensate siphon

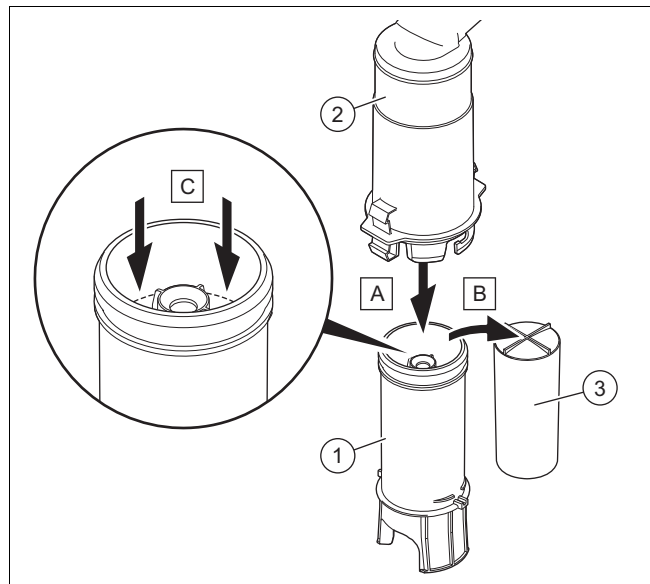

1. Unclip the lower section of the siphon (1) from the upper section of the siphon (2).
2. Remove the float (3).
3. Flush out the float and lower section of the siphon with water.

11 Inspection and maintenance

4. Fill the lower section of the siphon with water up to 10 mm below the upper edge of the condensate discharge pipe.
5. Re-insert the float (3).



Note

Check that the float is present in the condensate siphon.

6. Clip the lower section of the siphon (1) into the upper section of the siphon (2).

11.3.9 Cleaning the filter in the dynamic air separation system

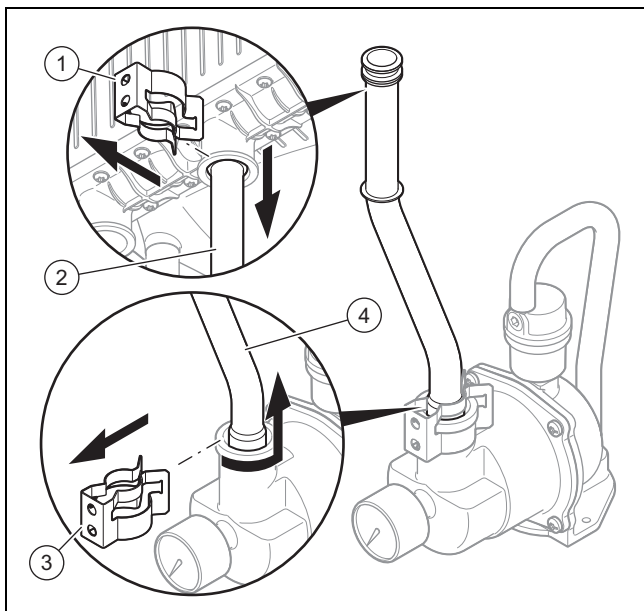

1. Remove the clips (1) and (3).
2. Loosen the upper section of the pipe (2).
3. Then turn and loosen the lower section of the pipe (4).

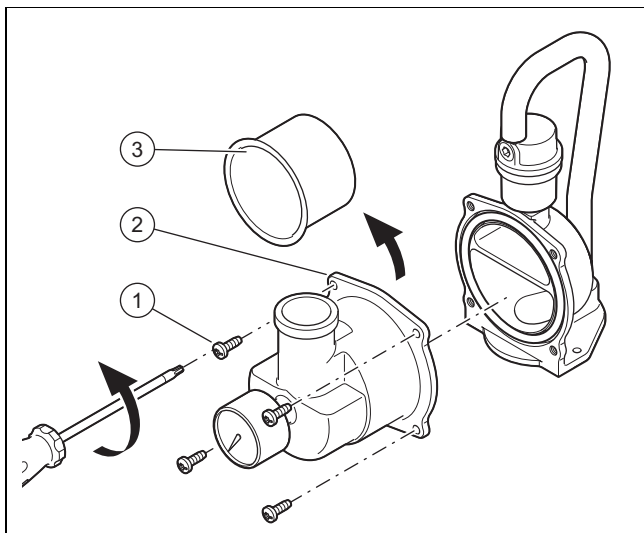

4. Remove the screws (1).
5. Remove the housing (2) from the air separation system.
6. Clean the filter (3) using hot water.
 - ▽ If the filter is damaged, replace it.
7. Insert the filter into the air separation system.

8. Replace the seal on the air separation system's housing.
9. Reattach the housing for the air separation system and use the screws to secure it in place.
 - Tightening torque: 7.5 Nm
10. Reinsert the pipe and insert the clip.

11.3.10 Checking the pre-charge pressure of the external expansion vessel

1. Depressurise the heating installation.
2. Measure the pre-charge pressure of the expansion vessel at the vessel valve.
 - ▽ Expansion vessel pre-charge pressure
 - ≥ 0.075 MPa (≥ 0.750 bar)
 - ▶ Fill the expansion vessel with air at a lower pre-charge pressure (in relation to the static height of the heating installation).
3. If water escapes from the valve of the expansion vessel, replace the expansion vessel.
4. Fill the heating installation. (→ Page 23)

11.3.11 Completing cleaning and inspection work

1. Tilt the electronics box upwards.
2. Install the front casing. (→ Page 11)
3. Establish the power supply if this has not yet been done.
4. Open the gas stopcock.
5. Switch the product back on if this has not yet been done. (→ Page 24)
6. Open all service valves and the gas stopcock if this has not yet been done.

11.4 Draining the product

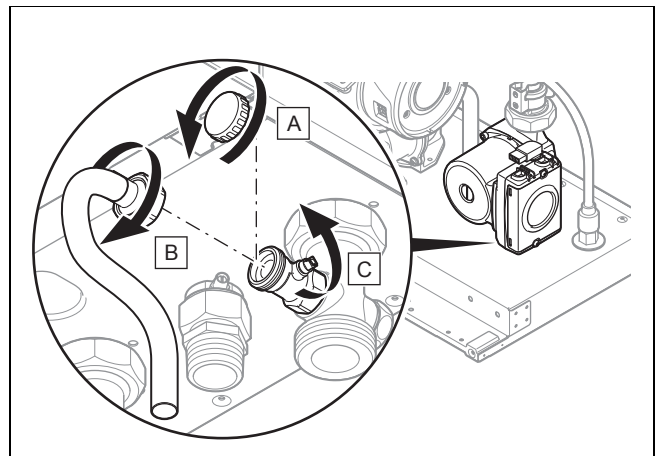

1. Close the service valves of the product.
2. Remove the cap (A) from the drain cock.
3. Connect a drain hose (B) to the connection on the drain cock.
4. Open the drain cock (C).
5. Use the air separator on the heating flow connection so that the product can be completely drained.

11.5 Completing inspection and maintenance work

- ▶ Check the gas flow pressure. (→ Page 26)
- ▶ Check the CO₂ content and, if necessary, adjust it (air ratio setting). (→ Page 27)
- ▶ Check that the product is leak-tight. (→ Page 28)
- ▶ If required, reset the maintenance interval. (→ Page 31)
- ▶ Log the inspection/maintenance work.

12 Decommissioning

12.1 Permanently decommissioning

- ▶ Decommission the product.
- ▶ Disconnect the product from the power grid.
- ▶ Close the gas stopcock.
- ▶ Close the heating stopcocks.
- ▶ Drain the product. (→ Page 40)

13 Recycling and disposal

Disposing of the packaging

- ▶ Dispose of the packaging correctly.
- ▶ Observe all relevant regulations.

14 Customer service

Applicability: New Zealand

For contact details for our customer service department, you can write to the address that is provided on the back page, or you can visit www.vaillant.com.

Applicability: Great Britain

OR Ireland

To ensure efficient and reliable operation of your boiler it is recommended that regular servicing is carried out by your service provider.

Appendix

A Overview of diagnostics codes

Applicability: VU 446/5-5 (H-GB)

OR VU 606/5-5 (H-GB)



Note

Since the code table is used for various products, some codes may not be visible for the product in question.

| Code | Parameter | Values or explanations | Default setting | User-specific setting |
|-------|--------------------------------------------------------------------------------------|--------------------------------------------------------------------------------------------------------------------------------------------------------------------------------------------|-----------------|-----------------------|
| D.000 | Partial heat load | Adjustable partial heat load in kW Auto: The product automatically adjusts the maximum partial load to the current system demand. | Auto | |
| D.001 | Overrun time for the internal pump after a heat demand | 2 ... 60 min | 5 min | |
| D.002 | Max. burner anti-cycling time in heating mode at 20 °C flow temperature | 2 ... 60 min | 20 min | |
| D.003 | Domestic hot water temperature | Not connect. | | |
| D.004 | Measured value for the cylinder temperature in °C | If a domestic hot water cylinder with sensor is connected | | Not adjustable |
| D.005 | Target value for the heating flow temperature (or target value for the return) in °C | The current target value, maximum value of the parameter that is set for D.071, limitation by an eBUS control, if connected | | Not adjustable |
| D.007 | Target value for the domestic hot water cylinder temperature in °C | (15 °C = frost protection, 40 °C up to D.020 (max. 70 °C)) | | Not adjustable |
| D.009 | Heating flow temperature, target value from external eBUS controller | °C | | |
| D.010 | Status of the internal heating pump | 0 = Off 1 = On | | Not adjustable |
| D.011 | Status of additional external heating pump | 0 = Off 1-100 = On | | Not adjustable |
| D.012 | Status of cylinder charging pump | 0 = Off 1-100 = On | | Not adjustable |
| D.013 | Status of circulation pump | 0 = Off 1-100 = On | | Not adjustable |
| D.014 | Setting for speed-controlled internal heating pump | 0 = auto (pump modulates in accordance with the control, with constant pressure) From 1 to 5 = Fixed pump setting – 1 = 53% – 2 = 60% – 3 = 70% – 4 = 85% – 5 = 100% | 0 | |
| D.015 | Current speed of the internal heating pump in % | | | Not adjustable |
| D.016 | 24 V DC room thermostat open/closed | Heating mode off/on | | Not adjustable |
| D.017 | Heating control type | 0 = Flow temperature control 1 = Return temperature control | 0 | |
| D.018 | Pump mode setting | 1 = Comfort (continuously operating pump) 3 = Eco (intermittently operating pump) | 3 | |
| D.020 | Max. set value for target cylinder value | 50 ... 65 °C | 65 °C | |
| D.022 | Domestic hot water demand | 0 = Off 1 = on | | Not adjustable |
| D.023 | Heating demand | 0 = Off 1 = on | | Not adjustable |

| Code | Parameter | Values or explanations | Default setting | User-specific setting |
|-------|--------------------------------------------------------------------------|------------------------------------------------------------------------------------------------------------------------------------------------------------------------------------------------------------------------------------------------------------------------------------------------------------|-----------------|-----------------------|
| D.024 | Status of the air pressure monitor | 0 = open 1 = closed | | Not adjustable |
| D.025 | Domestic hot water generation enabled by eBUS control | 0 = No 1 = Yes | | |
| D.026 | Control of the optional grey relay X16 | 1 = Circulation pump 2 = External pump 3 = Cylinder charging pump 4 = Smoke flap 5 = External solenoid valve 6 = External fault message 7 = Solar pump (not active) 8 = eBUS remote control (not active) 9 = Anti-legionella pump (not activated) 10 = Solar valve (not active) | 2 | |
| D.027 | Switching accessory relay 1 for 2 in 7 multi-functional module accessory | 1 = Circulation pump 2 = External pump 3 = Cylinder charging pump (not activated) 4 = Smoke flap 5 = External solenoid valve 6 = External fault message 7 = Solar pump (not active) 8 = eBUS remote control (not active) 9 = Anti-legionella pump (not activated) | 1 | |
| D.028 | Switching accessory relay 2 for 2 in 7 multi-functional module accessory | 1 = Circulation pump 2 = External pump 3 = Cylinder charging pump (not activated) 4 = Smoke flap 5 = External solenoid valve 6 = External fault message 7 = Solar pump (not active) 8 = eBUS remote control (not active) 9 = Anti-legionella pump (not activated) | 2 | |
| D.029 | Heating flow (heating circuit or cylinder charging) | l/min | | Not adjustable |
| D.033 | Fan speed target value | rpm | | Not adjustable |
| D.034 | Fan speed actual value | rpm | | Not adjustable |
| D.035 | Position of the prioritising diverter valve | Not connect. | | Not adjustable |
| D.040 | Flow temperature | Actual value in °C | | Not adjustable |
| D.041 | Return temperature | Actual value in °C | | Not adjustable |
| D.044 | Digitised ionisation value | 0 ... 1,020 Good flame < 400 No flame > 800 | | Not adjustable |
| D.047 | Outdoor temperature (with weather-compensated control) | Actual value in °C if an outdoor temperature sensor is connected to X41 | | Not adjustable |
| D.050 | Offset for minimum speed | 0 ... 3,000 rpm | 30 | |
| D.051 | Offset for maximum speed | -990 ... 0 rpm | -45 | |
| D.060 | Number of switch-off sequences for the safety cut-out | Number of shutdowns | | Not adjustable |
| D.061 | Number of flame sequence control faults | Number of unsuccessful ignitions in the last attempt | | Not adjustable |
| D.064 | Average ignition time | s | | Not adjustable |
| D.065 | Maximum ignition time | s | | Not adjustable |

Appendix

| Code | Parameter | Values or explanations | Default setting | User-specific setting |
|-------|-----------------------------------------------------------------------------------------------|--------------------------------------------------------------------------------------------------|-----------------|-----------------------|
| D.067 | Remaining burner anti-cycling time | min | | Not adjustable |
| D.068 | Unsuccessful ignitions at 1st attempt | Number of unsuccessful ignitions | | Not adjustable |
| D.069 | Unsuccessful ignitions at 2nd attempt | Number of unsuccessful ignitions | | Not adjustable |
| D.071 | Target value maximum heating flow temperature | 30 ... 80 °C | 75 °C | |
| D.072 | Overrun time for the heating pump after cylinder post-heating | 0 ... 600 s | 120 s | |
| D.074 | Anti-legionella function | Thermal disinfection is carried out every 24 hours 0 = Inactive 1 = Active | 0 | |
| D.075 | Maximum charging time for the domestic hot water cylinder | 20 ... 90 min | 45 min | |
| D.076 | Product-specific number | Unit variant display (DSN) | | Not adjustable |
| D.077 | Limit on cylinder charging output | Adjustable cylinder charging output in kW | Maximum output | |
| D.078 | Cylinder charging temperature limit (target flow temperature in cylinder charging mode) in °C | 55 ... 85 °C | 80 °C | |
| D.080 | Operating hours of the burner in heating mode | h | | Not adjustable |
| D.081 | Operating hours of the burner for domestic hot water generation | h | | Not adjustable |
| D.082 | Number of burner start-ups in heating mode | Number of burner start-ups (x 100) | | Not adjustable |
| D.083 | Number of burner starts in domestic hot water mode | Number of burner start-ups (x 100) | | Not adjustable |
| D.084 | Maintenance indicator: Number of hours until the next maintenance | 0 ... 3,000 h "-." to deactivate the function | „-“ | |
| D.085 | Minimum output of the product | kW | | |
| D.090 | Status of the eBUS control | 1 = Detected 2 = Not detected | | Not adjustable |
| D.091 | Status of DCF with outdoor temperature sensor connected | 0 = No reception 1 = Reception 2 = Synchronised 3 = Valid | | Not adjustable |
| D.093 | Unit variant setting (DSN) | Adjustment range: 170 to 199 The three-digit DSN code is located on the product's data plate. | | |
| D.094 | Delete fault history | Delete fault list 0 = No 1 = Yes | | |
| D.095 | Software version of PeBUS components | Main PCB (BMU) PCB for the control element (AI) | | Not adjustable |
| D.096 | Default setting | Reset all adjustable parameters to factory setting 0 = No 1 = Yes | 0 | |
| D.122 | Target value for the available pressure in the heating circuit | 100 ... 400 mbar | 200 mbar | |
| D.123 | Duration of last cylinder charging | min | | |
| D.124 | Domestic hot water cylinder in ECO mode | Not connect. | | |
| D.125 | Domestic hot water temperature at the cylinder outlet | Not connect. | | |
| D.126 | Back-up heater delay when there is sunlight | Not connect. | | |

| Code | Parameter | Values or explanations | Default setting | User-specific setting |
|-------|--------------------------------------------------------------------------|---------------------------------------------------------------------------------------------------------------------------------------------------------------------------------------------------------------------------------------------------------------------------------------------------------------------------------------------------------------------------------------|-----------------|-----------------------|
| D.148 | Target value for the available pressure in the cylinder charging circuit | 100 ... 400 mbar | 200 mbar | |
| D.149 | Precise information about circulation fault F.75 | If fault F.75 occurs, read the explanation below for the relevant value of the diagnostics code in order to analyse the problem. 0 = No fault 1 = Pump blocked 2 = Electrical pump fault 3 = Pump dry run 5 = Pressure sensor fault 6 = No feedback from the pump 7 = Incorrect pump detected 8 = Flow rate at the end of the purge programme is insufficient | | |

B Status codes – Overview

| Status code | Meaning |
|------------------------|------------------------------------------------------------------------------------------------------------------------------------------|
| Heating mode | |
| S.0 | Heating demand |
| S.1 | Heating mode: Fan start-up |
| S.2 | Heating mode: Pump start-up |
| S.3 | Heating mode: Ignition |
| S.4 | Heating mode: Burner on |
| S.5 | Heating mode: Pump/fan overrun |
| S.6 | Heating mode: Fan reduction |
| S.7 | Heating mode: Pump overrun |
| S.8 | Heating mode, burner anti-cycling time |
| Cylinder charging mode | |
| S.20 | Domestic hot water requirement |
| S.21 | DHW mode: Fan start-up |
| S.22 | Domestic hot water mode: Pump running |
| S.23 | DHW mode: Ignition |
| S.24 | DHW mode: Burner on |
| S.25 | DHW mode: Pump/fan overrun |
| S.26 | DHW mode: Fan overrun |
| S.27 | DHW mode: Pump overrun |
| S.28 | Domestic hot water burner anti-cycling time |
| Special cases | |
| S.30 | Room thermostat (RT) is blocking heating mode |
| S.31 | Summer mode active or no heat requirement from eBUS control |
| S.32 | Waiting period: Deviation in fan speed |
| S.33 | Air pressure switch calibration |
| S.34 | Frost protection mode active |
| S.36 | Reference setting for the continuous control 7-8-9 or eBUS control is < 20 °C and blocks the heating mode |
| S.39 | Limit thermostat for the underfloor heating triggered |
| S.41 | Water pressure too high |
| S.42 | Return signal for the flue non-return flap (only if an accessory) blocks burner operation or condensate pump faulty, heat demand blocked |
| S.53 | Modulation blocked by operating block function due to water deficiency (flow and return spread too great) |
| S.54 | Product in standby caused by operating blocking function as a result of water deficiency (temperature gradient) |
| S.85 | Service message "Insufficient water flow rate, product in standby mode for 10 minutes" |

Appendix

| Status code | Meaning |
|-------------|------------------------------------------------------------------|
| S.96 | Return sensor test running, heating demands are blocked. |
| S.97 | Water pressure sensor test running, heating demands are blocked. |
| S.98 | Flow/return sensor test running, heating demands are blocked. |
| S.108 | Purging process is running |

C Fault messages – Overview

| Message | Possible cause | Measure |
|------------------------------------------------------------|-------------------------------------------------------------------------|-------------------------------------------------------------------|
| F.00 Flow temperature sensor interruption | NTC plug loose/not plugged in | ▶ Check the NTC plug and plug connection. |
| | NTC sensor defective | ▶ Replace the NTC sensor. |
| | Multiple plug loose/not plugged in | ▶ Check the multiple plug and plug connection. |
| | Interruption in the cable harness | ▶ Check the cable harness. |
| F.01 Return temperature sensor interruption | NTC plug loose/not plugged in | ▶ Check the NTC plug and plug connection. |
| | NTC sensor defective | ▶ Replace the NTC sensor. |
| | Multiple plug loose/not plugged in | ▶ Check the multiple plug and plug connection. |
| | Interruption in the cable harness | ▶ Check the cable harness. |
| F.03 Cylinder temperature sensor interruption | NTC sensor defective | ▶ Replace the NTC sensor. |
| | NTC plug loose/not plugged in | ▶ Check the NTC plug and plug connection. |
| | Connection to cylinder electronics defective | ▶ Check the connection to the cylinder electronics. |
| F.10 Flow temperature sensor short circuit | NTC sensor defective | ▶ Replace the NTC sensor. |
| | Short circuit in the cable harness | ▶ Check the cable harness. |
| F.11 Return temperature sensor short circuit | NTC sensor defective | ▶ Replace the NTC sensor. |
| | Short circuit in the cable harness | ▶ Check the cable harness. |
| F.13 Cylinder temperature sensor short circuit | NTC sensor defective | ▶ Replace the NTC sensor. |
| | Short circuit in the cable harness | ▶ Check the cable harness. |
| F.20 Safety shutdown: Safety cut-out | Flow NTC defective | ▶ Check the flow NTC. |
| | Return NTC defective | ▶ Check the return NTC. |
| | Earth connection faulty | ▶ Check the earth connection. |
| | Stray spark via the ignition cable, ignition plug or ignition electrode | ▶ Check the ignition cable, ignition plug and ignition electrode. |
| F.22 Safety shutdown: Water deficiency | Insufficient/no water in the product. | ▶ Fill the heating installation. (→ Page 23) |
| | Interruption in the cable harness | ▶ Check the cable harness. |
| F.23 Safety shutdown: Temperature spread too great | Pump blocked | ▶ Check that the pump is working correctly. |
| | Pump runs with insufficient output | ▶ Check that the pump is working correctly. |
| | Flow and return NTC connected the wrong way round | ▶ Check the connection for the flow and return NTC. |
| F.24 Safety shutdown: Temperature rise too fast | Pump blocked | ▶ Check that the pump is working correctly. |
| | Pump runs with insufficient output | ▶ Check that the pump is working correctly. |
| | Non-return valve blocked | ▶ Check that the non-return valve is working correctly. |
| | Non-return valve installed incorrectly | ▶ Check the installation position of the non-return valve. |
| | System pressure too low | ▶ Check the system pressure. |
| F.25 Safety shutdown: Flue gas temperature too high | Flue gas safety cut-out plug is not plugged in or is loose | ▶ Check the plug and the plug connection. |
| | Interruption in the cable harness | ▶ Check the cable harness. |

| Message | Possible cause | Measure |
|----------------------------------------------------------------------|-------------------------------------------------------------------------------------------------------------------------------------------------------------------------------------|------------------------------------------------------------------------------------------------------------------------------------------|
| F.27 Safety shutdown: Flame simulation | Gas solenoid valve not leak-tight | ▶ Check that the gas solenoid valve works correctly. |
| | Moisture on the PCB | ▶ Check that the PCB works correctly. |
| | Flame monitor defective | ▶ Replace the flame monitor. |
| F.28 Ignition unsuccessful | Gas stopcock closed | ▶ Open the gas stopcock. |
| | Gas valve assembly defective | ▶ Replace the gas valve assembly. |
| | The gas pressure monitor has been triggered | ▶ Check the gas flow pressure. |
| | Gas flow pressure too low | ▶ Check the gas flow pressure. |
| | The thermal isolator device has been triggered | ▶ Check the thermal isolator device. |
| | Cable connections not plugged in/loose | ▶ Check the cable connections. |
| | Ignition system defective | ▶ Replace the ignition system. |
| | PCB defective | ▶ Replace the PCB. |
| | Ionisation flow interrupted | ▶ Check the monitoring electrodes. |
| | Earthing defective | ▶ Check the product's earthing. |
| | Air in the gas supply | ▶ Check the gas-air ratio. |
| | Gas meter defective | ▶ Replace the gas meter. |
| | Gas supply is interrupted | ▶ Check the gas supply. |
| | Flue gas circulation is incorrect | ▶ Check the air/flue system. |
| | Ignition misfire | ▶ Check that the ignition transformer works correctly. |
| | Diagnostics code D.085 incorrectly set | ▶ Using an installation with a flue non-return flap, check whether the diagnostics code D.085 has been set correctly. (→ Page 19) |
| Condensate siphon blocked | 1. Check whether the condensate discharge is connected correctly. (→ Page 18) 2. If the drain is blocked, check whether the heat exchanger's internal insulating material is OK. | |
| F.29 Ignition and check faults during operation – flame has gone out | Gas valve assembly defective | ▶ Replace the gas valve assembly. |
| | Gas meter defective | ▶ Replace the gas meter. |
| | The gas pressure monitor has been triggered | ▶ Check the gas flow pressure. |
| | Air in the gas supply | ▶ Check the gas-air ratio. |
| | Gas flow pressure too low | ▶ Check the gas flow pressure. |
| | The thermal isolator device has been triggered | ▶ Check the thermal isolator device. |
| | Cable connections not plugged in/loose | ▶ Check the cable connections. |
| | Ignition system defective | ▶ Replace the ignition system. |
| | Ionisation flow interrupted | ▶ Check the monitoring electrodes. |
| | Earthing defective | ▶ Check the product's earthing. |
| | PCB defective | ▶ Replace the PCB. |
| F.32 Fan fault | Plug on fan not plugged in or is loose | ▶ Check the plug on the fan and the plug connection. |
| | Multiple plug loose/not plugged in | ▶ Check the multiple plug and plug connection. |
| | Interruption in the cable harness | ▶ Check the cable harness. |
| | Fan blocked | ▶ Check that the fan works correctly. |
| | Electronics defective | ▶ Check the PCB. |
| F.33 Air pressure switch fault | Air/flue pipe blocked | ▶ Check the entire air/flue pipe. |
| | Defective air pressure switch | ▶ Replace the air pressure switch. |
| | Cable connections not plugged in/loose | ▶ Check the cable connections. |
| | Fan defective | ▶ Check that the fan works correctly. |

Appendix

| Message | Possible cause | Measure |
|---------------------------------------------------------------------------|----------------------------------------------------------------------|-----------------------------------------------------------------------------------------------------------------------------------------------------------------------------------------------------------|
| F.33 Air pressure switch fault | PCB defective | ▶ Replace the PCB. |
| | Excessive counter-pressure in the air/flue pipe | 1. Ensure that there is no risk of excessive counter-pressure. 2. If required, protect the product (wind guard, cascade lines with a larger diameter, etc.). |
| F.49 Fault: eBUS | eBUS overload | ▶ Check that the eBUS connection works correctly. |
| | Short circuit in the eBUS connection | ▶ Check that the eBUS connection works correctly. |
| | Different polarities at the eBUS connection | ▶ Check that the eBUS connection works correctly. |
| F.61 Gas safety valve drive fault | Short circuit in the cable harness | ▶ Check the cable harness. |
| | Gas valve assembly defective | ▶ Replace the gas valve assembly. |
| | PCB defective | ▶ Replace the PCB. |
| F.62 Gas safety valve connection fault | PCB defective | ▶ Replace the PCB. |
| | The connection to the gas valve assembly has been interrupted/broken | ▶ Check the connection to the gas valve assembly. |
| F.63 Fault: EEPROM | PCB defective | ▶ Replace the PCB. |
| F.64 Fault: Electronics/NTC | Flow NTC short circuit. | ▶ Check that the flow NTC works correctly. |
| | Return NTC short circuit | ▶ Check that the return NTC works correctly. |
| | PCB defective | ▶ Replace the PCB. |
| F.65 Electronics temperature fault | Electronics overheated | ▶ Check the external heat effects on the electronics. |
| | PCB defective | ▶ Replace the PCB and the ionisation electrode. |
| F.67 Flame plausibility fault | PCB defective | ▶ Replace the PCB. |
| F.70 Invalid device specific number (DSN) | Device Specific Number not set/is incorrect | ▶ Set the correct Device Specific Number. |
| | Output range coding resistor missing or is incorrect | ▶ Check the output range coding resistor. |
| F.71 Flow temperature sensor fault | The flow NTC reports a constant value | ▶ Check the positioning of the flow NTC. |
| | Incorrect position of the flow NTC | ▶ Check the positioning of the flow NTC. |
| | Flow NTC defective | ▶ Replace the flow NTC. |
| F.72 Flow and/or return temperature sensor fault | Flow NTC defective | ▶ Replace the flow NTC. |
| | Return NTC defective | ▶ Replace the return NTC. |
| F.73 Water pressure sensor signal in the wrong range (too low) | Short circuit in the cable harness | ▶ Check the cable harness. |
| | Interruption in the cable harness | ▶ Check the cable harness. |
| | Water pressure sensor defective | ▶ Replace the water pressure sensor. |
| F.74 Water pressure sensor signal outside correct range (too high) | Short circuit in the cable harness | ▶ Check the cable harness. |
| | Interruption in the cable harness | ▶ Check the cable harness. |
| | Water pressure sensor defective | ▶ Replace the water pressure sensor. |
| F.75 Pump fault/water deficiency | Malfunction | ▶ Call up diagnostics code D.149 to obtain further information about the malfunction. Overview of diagnostics codes (Applicability: VU 446/5-5 (H-GB) OR VU 606/5-5 (H-GB)) (→ Page 42) |
| | D.149 = 1, pump blocked alarm | 1. Remove the blockage from the pump. 2. Replace the pump. |
| | D.149 = 2, electrical pump fault alarm | 1. Check the pump's supply voltage. 2. Replace the pump. |
| | D.149 = 3, pump dry running alarm | 1. Check the pressure of the hydraulic circuit; ensure that there is no air in the circuit. 2. Replace the pump. |

| Message | Possible cause | Measure |
|--------------------------------------------------------------------------------------------|-------------------------------------------------------------------------------|---------------------------------------------------------------------------------------------------------------------------------------------------------------------------------------------------------------------------------------------------------------------------------------------------------------------------|
| F.75 Pump fault/water deficiency | D.149 = 5, no pressure peak detection | <ol style="list-style-type: none"> 1. Check the system pressure. 2. Purge the heating installation (purge programme). 3. Check the water pressure sensor. 4. Replace the water pressure sensor. |
| | D.149 = 6, no feedback from the pump | <ol style="list-style-type: none"> 1. Check the pump's cable harness. 2. Check the main PCB. 3. Check that the plugs are connected correctly. 4. Check the pump's supply voltage. – ≥ 195 V 5. Replace the pump. 6. Replace the main PCB. |
| | D.149 = 7, incorrect pump detected | <ol style="list-style-type: none"> 1. The detected pump is not correct for the product code; check the product code. 2. Use the pump that has the correct article number. |
| | D.149 = 8, flow rate at the end of the purge programme is insufficient | <ol style="list-style-type: none"> 1. Check whether the stopcocks and thermostatic valves are open. 2. Check the filling pressure; purge the circuit. – ≥ 0.15 MPa (≥ 1.50 bar) |
| F.77 Accessory fault (flue non-return flap, condensate pump, etc.) | No feedback from the flue non-return flap or the feedback is incorrect | ▶ Check that the flue non-return flap works without any problems. |
| | Flue non-return flap defective | ▶ Replace the flue non-return flap. |
| | No feedback from the condensate pump or the feedback is incorrect | ▶ Check that the condensate pump is working correctly. |
| F.83 Fault: Flow and/or return temperature sensor temperature change | Water deficiency | ▶ Fill the heating installation. (→ Page 23) |
| | Flow NTC: No contact | ▶ Check whether the flow NTC is lying against the flow pipe correctly. |
| | Return NTC: No contact | ▶ Check whether the return NTC is lying against the return pipe correctly. |
| F.84 Fault: Temperature difference at the flow and return temperature sensors | Flow NTC installed incorrectly | ▶ Check that the flow NTC has been installed correctly. |
| | Return NTC installed incorrectly | ▶ Check that the return NTC has been installed correctly. |
| F.85 Flow and return temperature sensors have been installed incorrectly (inverted) | Flow/return NTC installed on the same/incorrect pipe | ▶ Check that the flow and return NTCs have been installed on the correct pipe. |

| | | | |
|----|--------------------------------------------------------------------------|----|-------------------------------------------------------------------------------------------------|
| 1 | Main PCB (BMU) | 11 | Plug for the domestic hot water cylinder's contact (optional) |
| 2 | PCB for the control element (AI) | 12 | Water pressure sensor |
| 3 | Gas valve assembly | 13 | Heating pump control signal |
| 4 | Temperature sensor in the heating flow | 14 | Control of the optional relay D.026 |
| 5 | Temperature sensor in the heating return | 15 | Power supply for the prioritising diverter valve or domestic hot water charging pump (optional) |
| 6 | Pressure switch | 16 | Fan power supply |
| 7 | Control signal for the fan | 17 | Power supply for the heating pump |
| 8 | Plug that is enclosed with the system control (optional) | 18 | Igniter |
| 9 | Temperature sensor for the low loss header (optional) | 19 | Ignition electrode |
| 10 | Plug for the domestic hot water cylinder's temperature sensor (optional) | | |

Appendix

E Basic installation diagram

E.1 0020253233

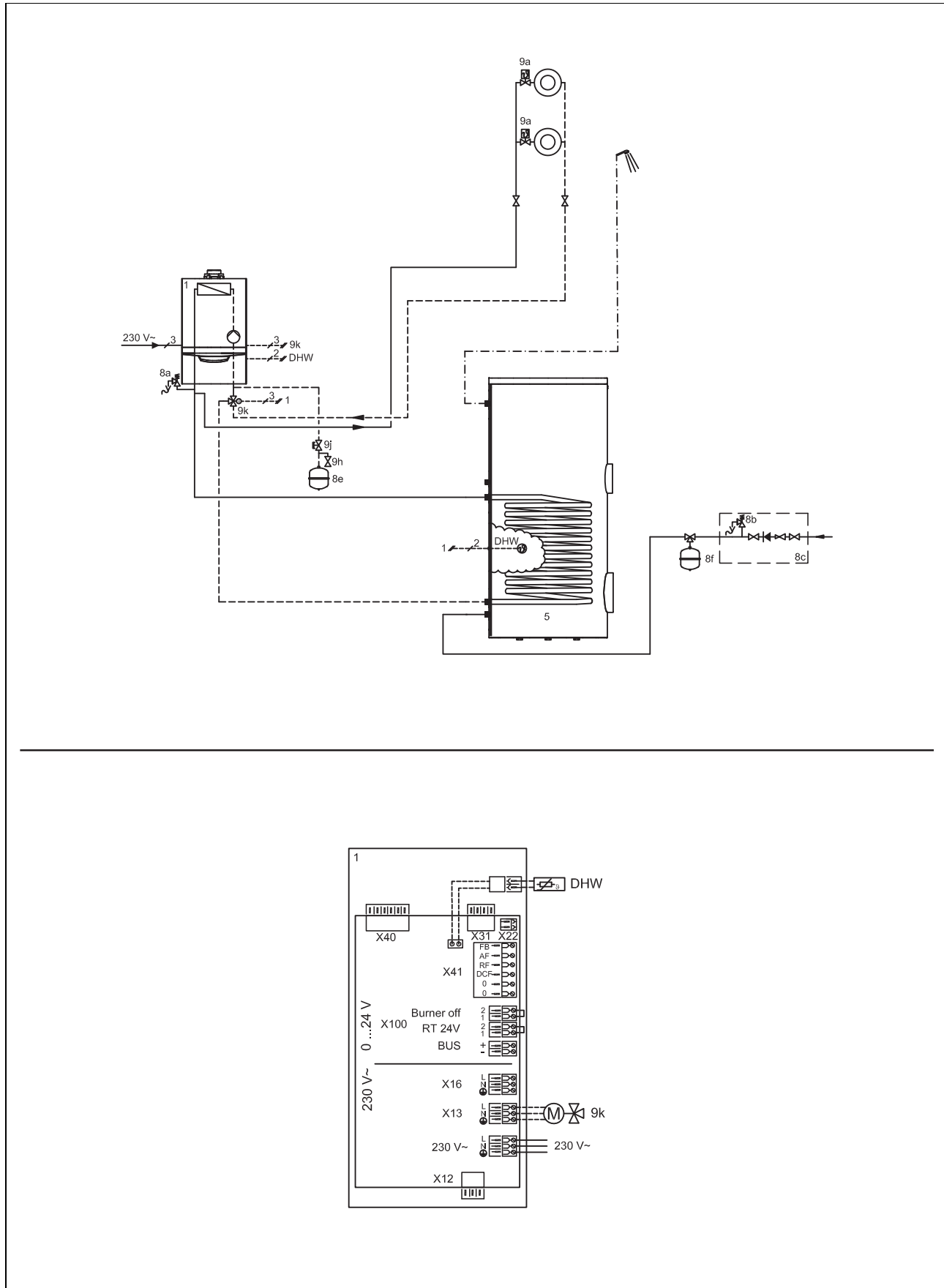

E.2 0020259030

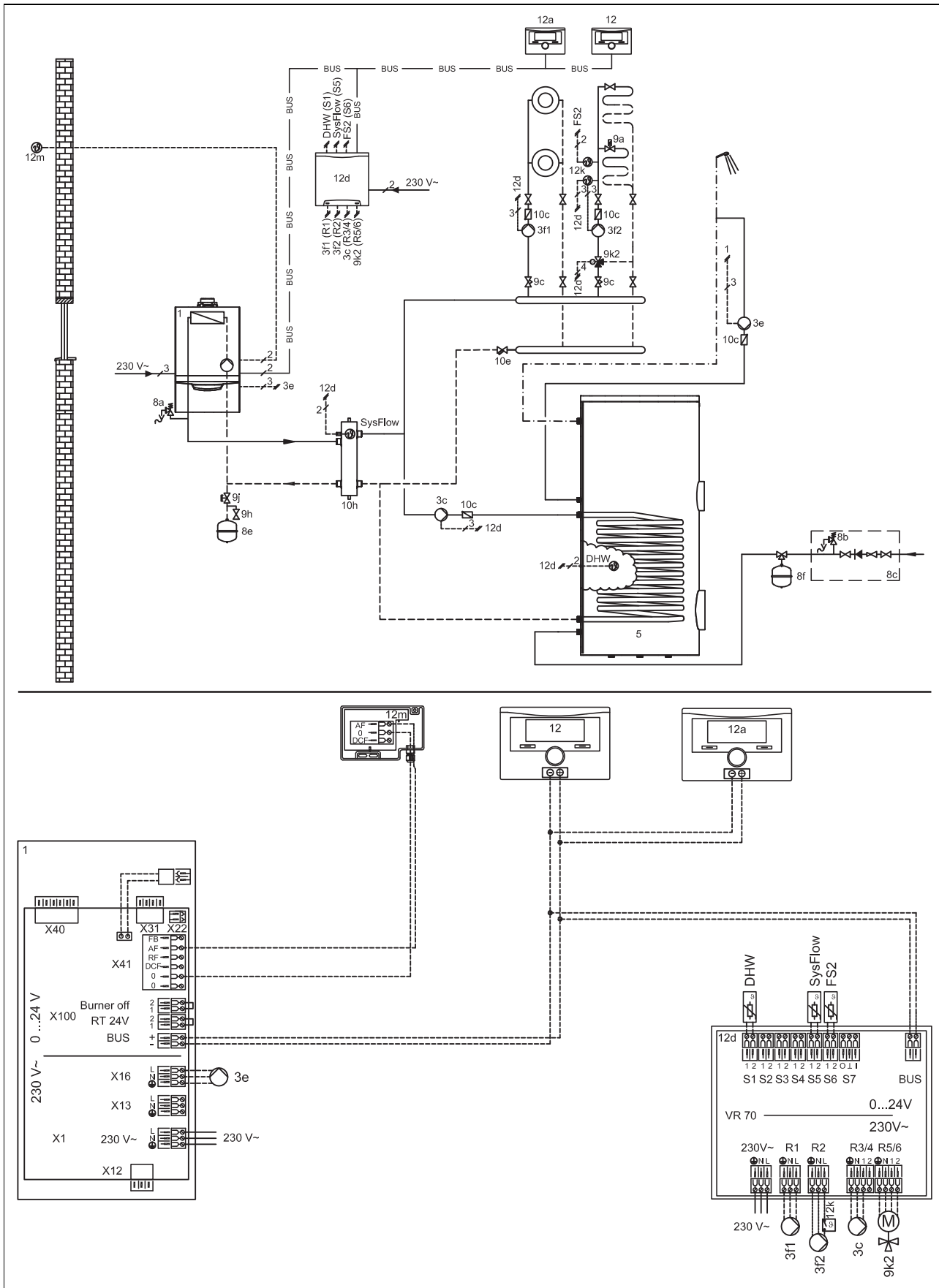

Appendix

E.3 Key for the basic system diagrams

| Component | Meaning |
|-------------------------------------------------------------------------------------------------|----------------------------------------------------------------|
| 1 | Heat generator |
| 3 | Heat generator circulation pump |
| 3c | Cylinder charging pump |
| 3e | Circulation pump |
| 3f | Heating pump |
| 5 | Monovalent domestic hot water cylinder |
| 8a | Expansion relief valve |
| 8b | Potable water expansion relief valve |
| 8c | Safety group – drinking water connection |
| 8e | Heating diaphragm expansion vessel |
| 8f | Diaphragm expansion vessel – potable water |
| 9a | Single-room temperature control valve (thermostatic/motorised) |
| 9c | Flow regulator valve |
| 9e | Domestic hot water generation prioritising diverter valve |
| 9h | Filling/draining cock |
| 9j | Tamper-proof capped valve |
| 9k | 3-port mixing valve |
| 10c | Non-return valve |
| 10e | Line strainer with magnetite separator |
| 10h | Low loss header |
| 12 | System control |
| 12a | Remote control unit |
| 12d | Expansion/wiring centre |
| 12k | Limit thermostat |
| 12m | Outdoor temperature sensor |
| DHW | Cylinder temperature sensor |
| FS2 | Heating circuit volume temperature sensor |
| SysFlow | System temperature sensor |
| Components that have been used multiple times (x) are numbered consecutively (x1, x2, ..., xn). | |

F Inspection and maintenance work – Overview

The table below lists the manufacturer requirements with respect to minimum inspection and maintenance intervals. If national regulations and directives require shorter inspection and maintenance intervals, you should observe these instead of the required intervals listed in the table. Carry out the preparatory work each time before inspection/maintenance work is carried out, and carry out the completion work each time after the inspection/maintenance work is carried out.



Note

For those appliances which are not part of an annual service agreement/policy, maintenance must be carried out at least every 5 years.

| # | Maintenance work | Interval |  |
|---|----------------------------------------------------------------------------------------------------------|-------------------------------------------|---------------------------------------------------------------------------------------|
| 1 | Checking leak-tightness | Each time maintenance work is carried out | 28 |
| 2 | Check the general condition of the product | Annually | |
| 3 | Remove any dirt from the product and vacuum chamber | Annually | |
| 4 | Inspect the heat cell (condition, corrosion, soot, damage) and, if required, carry out maintenance work. | Annually | |
| 5 | Checking the gas flow pressure | Annually | 26 |
| 6 | Checking the CO ₂ content and, if necessary, adjusting it (air ratio setting) | Annually | 27 |

| # | Maintenance work | Interval |  |
|----|-----------------------------------------------------------------------------------------------------------------------------------------------------------------|----------------------|-------------------------------------------------------------------------------------|
| 7 | Check that the connections/electrical plug connections have been connected correctly/function correctly | Annually | |
| 8 | Check that the gas stopcock and service valves function correctly | Annually | |
| 9 | Checking and treating the heating water/filling and supplementary water | Annually | 21 |
| 10 | Checking the pre-charge pressure of the external expansion vessel | at regular intervals | 40 |
| 11 | Cleaning the heat exchanger | at regular intervals | 38 |
| 12 | Checking the burner | at regular intervals | 38 |
| 13 | Checking the ignition electrode | at regular intervals | 39 |
| 14 | Cleaning the condensate siphon | Annually | 39 |
| 15 | Cleaning the filter in the dynamic air separation system | at regular intervals | 40 |
| 16 | Cleaning the rainwater collector's draining circuit | Annually | 39 |
| 17 | Cleaning the low loss header | at regular intervals | |
| 18 | Test that the product/heating installation and the domestic hot water generation (if required) are working correctly. If required, carry out a purging process. | Annually | |
| 19 | Check the product for gas, flue gas and water leaks | Annually | |
| 20 | Checking and, if required, correcting the position of the frost protection heating elements | Annually | |
| 21 | Completing inspection and maintenance work | Annually | 41 |

G Commissioning Checklist

Applicability: Great Britain

Benchmark Commissioning and Servicing Section

It is a requirement that the boiler is installed and commissioned to the manufacturers instructions and the data fields on the commissioning checklist completed in full.

To instigate the boiler guarantee the boiler needs to be registered with the manufacturer within one month of the installation.

To maintain the boiler guarantee it is essential that the boiler is serviced annually by a Gas Safe registered engineer who has been trained on the boiler installed. The service details should be recorded on the Benchmark Service Interval Record and left with the householder.



www.centralheating.co.uk

GAS BOILER SYSTEM COMMISSIONING CHECKLIST

This Commissioning Checklist is to be completed in full by the competent person who commissioned the boiler as a means of demonstrating compliance with the appropriate Building Regulations and then handed to the customer to keep for future reference.

Failure to install and commission according to the manufacturer's instructions and complete this Benchmark Commissioning Checklist will invalidate the warranty. This does not affect the customer's statutory rights.

| | |
|-------------------------------|---------------------------|
| Customer name: | Telephone number: |
| Address: | |
| Boiler make and model: | |
| Boiler serial number: | |
| Commissioned by (PRINT NAME): | Gas Safe register number: |
| Company name: | Telephone number: |
| Company address: | |
| Commissioning date: | |

To be completed by the customer on receipt of a Building Regulations Compliance Certificate*

Building Regulations Notification Number (if applicable):

| CONTROLS (tick the appropriate boxes) | | | |
|-------------------------------------------|------------------------------------------|--|------------------------------|
| Time and temperature control to heating | Room thermostat and programmer/timer | | Programmable room thermostat |
| | Load/weather compensation | | Optimum start control |
| Time and temperature control to hot water | Cylinder thermostat and programmer/timer | | Combination Boiler |
| Heating zone valves | Fitted | | Not required |
| Hot water zone valves | Fitted | | Not required |
| Thermostatic radiator valves | Fitted | | Not required |
| Automatic bypass to system | Fitted | | Not required |
| Boiler interlock | | | Provided |

| ALL SYSTEMS | | | |
|----------------------------------------------------------------------------------------------------------|----------|--------|--|
| The system has been flushed and cleaned in accordance with BS7593 and boiler manufacturer's instructions | Yes | | |
| What system cleaner was used? | | | |
| What inhibitor was used? | Quantity | litres | |
| Has a primary water system filter been installed? | Yes | No | |

| CENTRAL HEATING MODE measure and record: | | | |
|-------------------------------------------|--------------------|-----------------------|---------------------|
| Gas rate | m ³ /hr | OR | ft ³ /hr |
| Burner operating pressure (if applicable) | mbar | OR Gas inlet pressure | mbar |
| Central heating flow temperature | | | °C |
| Central heating return temperature | | | °C |

| COMBINATION BOILERS ONLY | | | |
|-------------------------------------------------------------------------------------|-----|----|--|
| Is the installation in a hard water area (above 200ppm)? | Yes | No | |
| If yes, and if required by the manufacturer, has a water scale reducer been fitted? | Yes | No | |
| What type of scale reducer has been fitted? | | | |

| DOMESTIC HOT WATER MODE Measure and Record: | | | |
|---------------------------------------------|--------------------|---------------------------------------|---------------------|
| Gas rate | m ³ /hr | OR | ft ³ /hr |
| Burner operating pressure (at maximum rate) | mbar | OR Gas inlet pressure at maximum rate | mbar |
| Cold water inlet temperature | | | °C |
| Hot water has been checked at all outlets | Yes | Temperature | °C |
| Water flow rate | | | l/min |

| CONDENSING BOILERS ONLY | |
|-----------------------------------------------------------------------------------------------------------------|-----|
| The condensate drain has been installed in accordance with the manufacturer's instructions and/or BS5546/BS6798 | Yes |

| ALL INSTALLATIONS | | | | | |
|--------------------------------------------------------------------------------------------------------------------------------|--------------------------------|----|-----|-----|--------------------------|
| Record the following: | At max. rate: | CO | ppm | AND | CO/CO ₂ Ratio |
| | At min. rate: (where possible) | CO | ppm | AND | CO/CO ₂ Ratio |
| The heating and hot water system complies with the appropriate Building Regulations | Yes | | | | |
| The boiler and associated products have been installed and commissioned in accordance with the manufacturer's instructions | Yes | | | | |
| The operation of the boiler and system controls have been demonstrated to and understood by the customer | Yes | | | | |
| The manufacturer's literature, including Benchmark Checklist and Service Record, has been explained and left with the customer | Yes | | | | |

| |
|----------------------------------------------------------------------------------|
| Commissioning Engineer's Signature |
| Customer's Signature |
| (To confirm satisfactory demonstration and receipt of manufacturer's literature) |

*All installations in England and Wales must be notified to Local Authority Building Control (LABC) either directly or through a Competent Persons Scheme. A Building Regulations Compliance Certificate will then be issued to the customer.



SERVICE RECORD

It is recommended that your heating system is serviced regularly and that the appropriate Service Interval Record is completed.

Service Provider

Before completing the appropriate Service Record below, please ensure you have carried out the service as described in the manufacturer's instructions. Always use the manufacturer's specified spare part when replacing controls.

| | | | | | | | | | | | | | | | | | | | | | | | | | | | | | | | | | | | | | | | | | | | | | | | | | | | | | | | | | | | | | | | | | | | | | | | | | |
|-----------------------------------------------------------------------------------------------------------------------------------------------------------------------------------------------------------------------------------------------------------------------------------------------------------------------------------------------------------------------------------------------------------------------------------------------------------------------------------------------------------------------------------------------------------------------------------------------------------------------------------------------------------|--------------------------------|--------|-----------------------|--|----------------|--|--|--|---------------|--|--|--|---------------|--|--|--|-----------------------|--|--|--|---------|---------------|--------|-----------------------|--|--------------------------------|--------|-----------------------|-----------|--|--|--|-----------|--|--|--|-----------------------------------------------------------------------------------------------------------------------------------------------------------------------------------------------------------------------------------------------------------------------------------------------------------------------------------------------------------------------------------------------------------------------------------------------------------------------------------------------------------------------------------------------------------------------------------------------------------------------------------------------------------|-------------------|--|-------|--|----------------|--|--|--|---------------|--|--|--|---------------|--|--|--|-----------------------|--|--|--|---------|---------------|--------|-----------------------|--|--------------------------------|--------|-----------------------|-----------|--|--|--|-----------|--|--|--|
| <table border="1" style="width: 100%; border-collapse: collapse;"> <tr> <td colspan="2">SERVICE 01</td> <td colspan="2">Date:</td> </tr> <tr> <td colspan="4">Engineer name:</td> </tr> <tr> <td colspan="4">Company name:</td> </tr> <tr> <td colspan="4">Telephone No:</td> </tr> <tr> <td colspan="4">Gas safe register No:</td> </tr> <tr> <td>Record:</td> <td>At max. rate:</td> <td>CO ppm</td> <td>AND CO₂ %</td> </tr> <tr> <td></td> <td>At min. rate: (Where Possible)</td> <td>CO ppm</td> <td>AND CO₂ %</td> </tr> <tr> <td colspan="4">Comments:</td> </tr> <tr> <td colspan="4">Signature</td> </tr> </table> | SERVICE 01 | | Date: | | Engineer name: | | | | Company name: | | | | Telephone No: | | | | Gas safe register No: | | | | Record: | At max. rate: | CO ppm | AND CO ₂ % | | At min. rate: (Where Possible) | CO ppm | AND CO ₂ % | Comments: | | | | Signature | | | | <table border="1" style="width: 100%; border-collapse: collapse;"> <tr> <td colspan="2">SERVICE 02</td> <td colspan="2">Date:</td> </tr> <tr> <td colspan="4">Engineer name:</td> </tr> <tr> <td colspan="4">Company name:</td> </tr> <tr> <td colspan="4">Telephone No:</td> </tr> <tr> <td colspan="4">Gas safe register No:</td> </tr> <tr> <td>Record:</td> <td>At max. rate:</td> <td>CO ppm</td> <td>AND CO₂ %</td> </tr> <tr> <td></td> <td>At min. rate: (Where Possible)</td> <td>CO ppm</td> <td>AND CO₂ %</td> </tr> <tr> <td colspan="4">Comments:</td> </tr> <tr> <td colspan="4">Signature</td> </tr> </table> | SERVICE 02 | | Date: | | Engineer name: | | | | Company name: | | | | Telephone No: | | | | Gas safe register No: | | | | Record: | At max. rate: | CO ppm | AND CO ₂ % | | At min. rate: (Where Possible) | CO ppm | AND CO ₂ % | Comments: | | | | Signature | | | |
| SERVICE 01 | | Date: | | | | | | | | | | | | | | | | | | | | | | | | | | | | | | | | | | | | | | | | | | | | | | | | | | | | | | | | | | | | | | | | | | | | | | | |
| Engineer name: | | | | | | | | | | | | | | | | | | | | | | | | | | | | | | | | | | | | | | | | | | | | | | | | | | | | | | | | | | | | | | | | | | | | | | | | | |
| Company name: | | | | | | | | | | | | | | | | | | | | | | | | | | | | | | | | | | | | | | | | | | | | | | | | | | | | | | | | | | | | | | | | | | | | | | | | | |
| Telephone No: | | | | | | | | | | | | | | | | | | | | | | | | | | | | | | | | | | | | | | | | | | | | | | | | | | | | | | | | | | | | | | | | | | | | | | | | | |
| Gas safe register No: | | | | | | | | | | | | | | | | | | | | | | | | | | | | | | | | | | | | | | | | | | | | | | | | | | | | | | | | | | | | | | | | | | | | | | | | | |
| Record: | At max. rate: | CO ppm | AND CO ₂ % | | | | | | | | | | | | | | | | | | | | | | | | | | | | | | | | | | | | | | | | | | | | | | | | | | | | | | | | | | | | | | | | | | | | | | |
| | At min. rate: (Where Possible) | CO ppm | AND CO ₂ % | | | | | | | | | | | | | | | | | | | | | | | | | | | | | | | | | | | | | | | | | | | | | | | | | | | | | | | | | | | | | | | | | | | | | | |
| Comments: | | | | | | | | | | | | | | | | | | | | | | | | | | | | | | | | | | | | | | | | | | | | | | | | | | | | | | | | | | | | | | | | | | | | | | | | | |
| Signature | | | | | | | | | | | | | | | | | | | | | | | | | | | | | | | | | | | | | | | | | | | | | | | | | | | | | | | | | | | | | | | | | | | | | | | | | |
| SERVICE 02 | | Date: | | | | | | | | | | | | | | | | | | | | | | | | | | | | | | | | | | | | | | | | | | | | | | | | | | | | | | | | | | | | | | | | | | | | | | | |
| Engineer name: | | | | | | | | | | | | | | | | | | | | | | | | | | | | | | | | | | | | | | | | | | | | | | | | | | | | | | | | | | | | | | | | | | | | | | | | | |
| Company name: | | | | | | | | | | | | | | | | | | | | | | | | | | | | | | | | | | | | | | | | | | | | | | | | | | | | | | | | | | | | | | | | | | | | | | | | | |
| Telephone No: | | | | | | | | | | | | | | | | | | | | | | | | | | | | | | | | | | | | | | | | | | | | | | | | | | | | | | | | | | | | | | | | | | | | | | | | | |
| Gas safe register No: | | | | | | | | | | | | | | | | | | | | | | | | | | | | | | | | | | | | | | | | | | | | | | | | | | | | | | | | | | | | | | | | | | | | | | | | | |
| Record: | At max. rate: | CO ppm | AND CO ₂ % | | | | | | | | | | | | | | | | | | | | | | | | | | | | | | | | | | | | | | | | | | | | | | | | | | | | | | | | | | | | | | | | | | | | | | |
| | At min. rate: (Where Possible) | CO ppm | AND CO ₂ % | | | | | | | | | | | | | | | | | | | | | | | | | | | | | | | | | | | | | | | | | | | | | | | | | | | | | | | | | | | | | | | | | | | | | | |
| Comments: | | | | | | | | | | | | | | | | | | | | | | | | | | | | | | | | | | | | | | | | | | | | | | | | | | | | | | | | | | | | | | | | | | | | | | | | | |
| Signature | | | | | | | | | | | | | | | | | | | | | | | | | | | | | | | | | | | | | | | | | | | | | | | | | | | | | | | | | | | | | | | | | | | | | | | | | |
| <table border="1" style="width: 100%; border-collapse: collapse;"> <tr> <td colspan="2">SERVICE 03</td> <td colspan="2">Date:</td> </tr> <tr> <td colspan="4">Engineer name:</td> </tr> <tr> <td colspan="4">Company name:</td> </tr> <tr> <td colspan="4">Telephone No:</td> </tr> <tr> <td colspan="4">Gas safe register No:</td> </tr> <tr> <td>Record:</td> <td>At max. rate:</td> <td>CO ppm</td> <td>AND CO₂ %</td> </tr> <tr> <td></td> <td>At min. rate: (Where Possible)</td> <td>CO ppm</td> <td>AND CO₂ %</td> </tr> <tr> <td colspan="4">Comments:</td> </tr> <tr> <td colspan="4">Signature</td> </tr> </table> | SERVICE 03 | | Date: | | Engineer name: | | | | Company name: | | | | Telephone No: | | | | Gas safe register No: | | | | Record: | At max. rate: | CO ppm | AND CO ₂ % | | At min. rate: (Where Possible) | CO ppm | AND CO ₂ % | Comments: | | | | Signature | | | | <table border="1" style="width: 100%; border-collapse: collapse;"> <tr> <td colspan="2">SERVICE 04</td> <td colspan="2">Date:</td> </tr> <tr> <td colspan="4">Engineer name:</td> </tr> <tr> <td colspan="4">Company name:</td> </tr> <tr> <td colspan="4">Telephone No:</td> </tr> <tr> <td colspan="4">Gas safe register No:</td> </tr> <tr> <td>Record:</td> <td>At max. rate:</td> <td>CO ppm</td> <td>AND CO₂ %</td> </tr> <tr> <td></td> <td>At min. rate: (Where Possible)</td> <td>CO ppm</td> <td>AND CO₂ %</td> </tr> <tr> <td colspan="4">Comments:</td> </tr> <tr> <td colspan="4">Signature</td> </tr> </table> | SERVICE 04 | | Date: | | Engineer name: | | | | Company name: | | | | Telephone No: | | | | Gas safe register No: | | | | Record: | At max. rate: | CO ppm | AND CO ₂ % | | At min. rate: (Where Possible) | CO ppm | AND CO ₂ % | Comments: | | | | Signature | | | |
| SERVICE 03 | | Date: | | | | | | | | | | | | | | | | | | | | | | | | | | | | | | | | | | | | | | | | | | | | | | | | | | | | | | | | | | | | | | | | | | | | | | | |
| Engineer name: | | | | | | | | | | | | | | | | | | | | | | | | | | | | | | | | | | | | | | | | | | | | | | | | | | | | | | | | | | | | | | | | | | | | | | | | | |
| Company name: | | | | | | | | | | | | | | | | | | | | | | | | | | | | | | | | | | | | | | | | | | | | | | | | | | | | | | | | | | | | | | | | | | | | | | | | | |
| Telephone No: | | | | | | | | | | | | | | | | | | | | | | | | | | | | | | | | | | | | | | | | | | | | | | | | | | | | | | | | | | | | | | | | | | | | | | | | | |
| Gas safe register No: | | | | | | | | | | | | | | | | | | | | | | | | | | | | | | | | | | | | | | | | | | | | | | | | | | | | | | | | | | | | | | | | | | | | | | | | | |
| Record: | At max. rate: | CO ppm | AND CO ₂ % | | | | | | | | | | | | | | | | | | | | | | | | | | | | | | | | | | | | | | | | | | | | | | | | | | | | | | | | | | | | | | | | | | | | | | |
| | At min. rate: (Where Possible) | CO ppm | AND CO ₂ % | | | | | | | | | | | | | | | | | | | | | | | | | | | | | | | | | | | | | | | | | | | | | | | | | | | | | | | | | | | | | | | | | | | | | | |
| Comments: | | | | | | | | | | | | | | | | | | | | | | | | | | | | | | | | | | | | | | | | | | | | | | | | | | | | | | | | | | | | | | | | | | | | | | | | | |
| Signature | | | | | | | | | | | | | | | | | | | | | | | | | | | | | | | | | | | | | | | | | | | | | | | | | | | | | | | | | | | | | | | | | | | | | | | | | |
| SERVICE 04 | | Date: | | | | | | | | | | | | | | | | | | | | | | | | | | | | | | | | | | | | | | | | | | | | | | | | | | | | | | | | | | | | | | | | | | | | | | | |
| Engineer name: | | | | | | | | | | | | | | | | | | | | | | | | | | | | | | | | | | | | | | | | | | | | | | | | | | | | | | | | | | | | | | | | | | | | | | | | | |
| Company name: | | | | | | | | | | | | | | | | | | | | | | | | | | | | | | | | | | | | | | | | | | | | | | | | | | | | | | | | | | | | | | | | | | | | | | | | | |
| Telephone No: | | | | | | | | | | | | | | | | | | | | | | | | | | | | | | | | | | | | | | | | | | | | | | | | | | | | | | | | | | | | | | | | | | | | | | | | | |
| Gas safe register No: | | | | | | | | | | | | | | | | | | | | | | | | | | | | | | | | | | | | | | | | | | | | | | | | | | | | | | | | | | | | | | | | | | | | | | | | | |
| Record: | At max. rate: | CO ppm | AND CO ₂ % | | | | | | | | | | | | | | | | | | | | | | | | | | | | | | | | | | | | | | | | | | | | | | | | | | | | | | | | | | | | | | | | | | | | | | |
| | At min. rate: (Where Possible) | CO ppm | AND CO ₂ % | | | | | | | | | | | | | | | | | | | | | | | | | | | | | | | | | | | | | | | | | | | | | | | | | | | | | | | | | | | | | | | | | | | | | | |
| Comments: | | | | | | | | | | | | | | | | | | | | | | | | | | | | | | | | | | | | | | | | | | | | | | | | | | | | | | | | | | | | | | | | | | | | | | | | | |
| Signature | | | | | | | | | | | | | | | | | | | | | | | | | | | | | | | | | | | | | | | | | | | | | | | | | | | | | | | | | | | | | | | | | | | | | | | | | |
| <table border="1" style="width: 100%; border-collapse: collapse;"> <tr> <td colspan="2">SERVICE 05</td> <td colspan="2">Date:</td> </tr> <tr> <td colspan="4">Engineer name:</td> </tr> <tr> <td colspan="4">Company name:</td> </tr> <tr> <td colspan="4">Telephone No:</td> </tr> <tr> <td colspan="4">Gas safe register No:</td> </tr> <tr> <td>Record:</td> <td>At max. rate:</td> <td>CO ppm</td> <td>AND CO₂ %</td> </tr> <tr> <td></td> <td>At min. rate: (Where Possible)</td> <td>CO ppm</td> <td>AND CO₂ %</td> </tr> <tr> <td colspan="4">Comments:</td> </tr> <tr> <td colspan="4">Signature</td> </tr> </table> | SERVICE 05 | | Date: | | Engineer name: | | | | Company name: | | | | Telephone No: | | | | Gas safe register No: | | | | Record: | At max. rate: | CO ppm | AND CO ₂ % | | At min. rate: (Where Possible) | CO ppm | AND CO ₂ % | Comments: | | | | Signature | | | | <table border="1" style="width: 100%; border-collapse: collapse;"> <tr> <td colspan="2">SERVICE 06</td> <td colspan="2">Date:</td> </tr> <tr> <td colspan="4">Engineer name:</td> </tr> <tr> <td colspan="4">Company name:</td> </tr> <tr> <td colspan="4">Telephone No:</td> </tr> <tr> <td colspan="4">Gas safe register No:</td> </tr> <tr> <td>Record:</td> <td>At max. rate:</td> <td>CO ppm</td> <td>AND CO₂ %</td> </tr> <tr> <td></td> <td>At min. rate: (Where Possible)</td> <td>CO ppm</td> <td>AND CO₂ %</td> </tr> <tr> <td colspan="4">Comments:</td> </tr> <tr> <td colspan="4">Signature</td> </tr> </table> | SERVICE 06 | | Date: | | Engineer name: | | | | Company name: | | | | Telephone No: | | | | Gas safe register No: | | | | Record: | At max. rate: | CO ppm | AND CO ₂ % | | At min. rate: (Where Possible) | CO ppm | AND CO ₂ % | Comments: | | | | Signature | | | |
| SERVICE 05 | | Date: | | | | | | | | | | | | | | | | | | | | | | | | | | | | | | | | | | | | | | | | | | | | | | | | | | | | | | | | | | | | | | | | | | | | | | | |
| Engineer name: | | | | | | | | | | | | | | | | | | | | | | | | | | | | | | | | | | | | | | | | | | | | | | | | | | | | | | | | | | | | | | | | | | | | | | | | | |
| Company name: | | | | | | | | | | | | | | | | | | | | | | | | | | | | | | | | | | | | | | | | | | | | | | | | | | | | | | | | | | | | | | | | | | | | | | | | | |
| Telephone No: | | | | | | | | | | | | | | | | | | | | | | | | | | | | | | | | | | | | | | | | | | | | | | | | | | | | | | | | | | | | | | | | | | | | | | | | | |
| Gas safe register No: | | | | | | | | | | | | | | | | | | | | | | | | | | | | | | | | | | | | | | | | | | | | | | | | | | | | | | | | | | | | | | | | | | | | | | | | | |
| Record: | At max. rate: | CO ppm | AND CO ₂ % | | | | | | | | | | | | | | | | | | | | | | | | | | | | | | | | | | | | | | | | | | | | | | | | | | | | | | | | | | | | | | | | | | | | | | |
| | At min. rate: (Where Possible) | CO ppm | AND CO ₂ % | | | | | | | | | | | | | | | | | | | | | | | | | | | | | | | | | | | | | | | | | | | | | | | | | | | | | | | | | | | | | | | | | | | | | | |
| Comments: | | | | | | | | | | | | | | | | | | | | | | | | | | | | | | | | | | | | | | | | | | | | | | | | | | | | | | | | | | | | | | | | | | | | | | | | | |
| Signature | | | | | | | | | | | | | | | | | | | | | | | | | | | | | | | | | | | | | | | | | | | | | | | | | | | | | | | | | | | | | | | | | | | | | | | | | |
| SERVICE 06 | | Date: | | | | | | | | | | | | | | | | | | | | | | | | | | | | | | | | | | | | | | | | | | | | | | | | | | | | | | | | | | | | | | | | | | | | | | | |
| Engineer name: | | | | | | | | | | | | | | | | | | | | | | | | | | | | | | | | | | | | | | | | | | | | | | | | | | | | | | | | | | | | | | | | | | | | | | | | | |
| Company name: | | | | | | | | | | | | | | | | | | | | | | | | | | | | | | | | | | | | | | | | | | | | | | | | | | | | | | | | | | | | | | | | | | | | | | | | | |
| Telephone No: | | | | | | | | | | | | | | | | | | | | | | | | | | | | | | | | | | | | | | | | | | | | | | | | | | | | | | | | | | | | | | | | | | | | | | | | | |
| Gas safe register No: | | | | | | | | | | | | | | | | | | | | | | | | | | | | | | | | | | | | | | | | | | | | | | | | | | | | | | | | | | | | | | | | | | | | | | | | | |
| Record: | At max. rate: | CO ppm | AND CO ₂ % | | | | | | | | | | | | | | | | | | | | | | | | | | | | | | | | | | | | | | | | | | | | | | | | | | | | | | | | | | | | | | | | | | | | | | |
| | At min. rate: (Where Possible) | CO ppm | AND CO ₂ % | | | | | | | | | | | | | | | | | | | | | | | | | | | | | | | | | | | | | | | | | | | | | | | | | | | | | | | | | | | | | | | | | | | | | | |
| Comments: | | | | | | | | | | | | | | | | | | | | | | | | | | | | | | | | | | | | | | | | | | | | | | | | | | | | | | | | | | | | | | | | | | | | | | | | | |
| Signature | | | | | | | | | | | | | | | | | | | | | | | | | | | | | | | | | | | | | | | | | | | | | | | | | | | | | | | | | | | | | | | | | | | | | | | | | |
| <table border="1" style="width: 100%; border-collapse: collapse;"> <tr> <td colspan="2">SERVICE 07</td> <td colspan="2">Date:</td> </tr> <tr> <td colspan="4">Engineer name:</td> </tr> <tr> <td colspan="4">Company name:</td> </tr> <tr> <td colspan="4">Telephone No:</td> </tr> <tr> <td colspan="4">Gas safe register No:</td> </tr> <tr> <td>Record:</td> <td>At max. rate:</td> <td>CO ppm</td> <td>AND CO₂ %</td> </tr> <tr> <td></td> <td>At min. rate: (Where Possible)</td> <td>CO ppm</td> <td>AND CO₂ %</td> </tr> <tr> <td colspan="4">Comments:</td> </tr> <tr> <td colspan="4">Signature</td> </tr> </table> | SERVICE 07 | | Date: | | Engineer name: | | | | Company name: | | | | Telephone No: | | | | Gas safe register No: | | | | Record: | At max. rate: | CO ppm | AND CO ₂ % | | At min. rate: (Where Possible) | CO ppm | AND CO ₂ % | Comments: | | | | Signature | | | | <table border="1" style="width: 100%; border-collapse: collapse;"> <tr> <td colspan="2">SERVICE 08</td> <td colspan="2">Date:</td> </tr> <tr> <td colspan="4">Engineer name:</td> </tr> <tr> <td colspan="4">Company name:</td> </tr> <tr> <td colspan="4">Telephone No:</td> </tr> <tr> <td colspan="4">Gas safe register No:</td> </tr> <tr> <td>Record:</td> <td>At max. rate:</td> <td>CO ppm</td> <td>AND CO₂ %</td> </tr> <tr> <td></td> <td>At min. rate: (Where Possible)</td> <td>CO ppm</td> <td>AND CO₂ %</td> </tr> <tr> <td colspan="4">Comments:</td> </tr> <tr> <td colspan="4">Signature</td> </tr> </table> | SERVICE 08 | | Date: | | Engineer name: | | | | Company name: | | | | Telephone No: | | | | Gas safe register No: | | | | Record: | At max. rate: | CO ppm | AND CO ₂ % | | At min. rate: (Where Possible) | CO ppm | AND CO ₂ % | Comments: | | | | Signature | | | |
| SERVICE 07 | | Date: | | | | | | | | | | | | | | | | | | | | | | | | | | | | | | | | | | | | | | | | | | | | | | | | | | | | | | | | | | | | | | | | | | | | | | | |
| Engineer name: | | | | | | | | | | | | | | | | | | | | | | | | | | | | | | | | | | | | | | | | | | | | | | | | | | | | | | | | | | | | | | | | | | | | | | | | | |
| Company name: | | | | | | | | | | | | | | | | | | | | | | | | | | | | | | | | | | | | | | | | | | | | | | | | | | | | | | | | | | | | | | | | | | | | | | | | | |
| Telephone No: | | | | | | | | | | | | | | | | | | | | | | | | | | | | | | | | | | | | | | | | | | | | | | | | | | | | | | | | | | | | | | | | | | | | | | | | | |
| Gas safe register No: | | | | | | | | | | | | | | | | | | | | | | | | | | | | | | | | | | | | | | | | | | | | | | | | | | | | | | | | | | | | | | | | | | | | | | | | | |
| Record: | At max. rate: | CO ppm | AND CO ₂ % | | | | | | | | | | | | | | | | | | | | | | | | | | | | | | | | | | | | | | | | | | | | | | | | | | | | | | | | | | | | | | | | | | | | | | |
| | At min. rate: (Where Possible) | CO ppm | AND CO ₂ % | | | | | | | | | | | | | | | | | | | | | | | | | | | | | | | | | | | | | | | | | | | | | | | | | | | | | | | | | | | | | | | | | | | | | | |
| Comments: | | | | | | | | | | | | | | | | | | | | | | | | | | | | | | | | | | | | | | | | | | | | | | | | | | | | | | | | | | | | | | | | | | | | | | | | | |
| Signature | | | | | | | | | | | | | | | | | | | | | | | | | | | | | | | | | | | | | | | | | | | | | | | | | | | | | | | | | | | | | | | | | | | | | | | | | |
| SERVICE 08 | | Date: | | | | | | | | | | | | | | | | | | | | | | | | | | | | | | | | | | | | | | | | | | | | | | | | | | | | | | | | | | | | | | | | | | | | | | | |
| Engineer name: | | | | | | | | | | | | | | | | | | | | | | | | | | | | | | | | | | | | | | | | | | | | | | | | | | | | | | | | | | | | | | | | | | | | | | | | | |
| Company name: | | | | | | | | | | | | | | | | | | | | | | | | | | | | | | | | | | | | | | | | | | | | | | | | | | | | | | | | | | | | | | | | | | | | | | | | | |
| Telephone No: | | | | | | | | | | | | | | | | | | | | | | | | | | | | | | | | | | | | | | | | | | | | | | | | | | | | | | | | | | | | | | | | | | | | | | | | | |
| Gas safe register No: | | | | | | | | | | | | | | | | | | | | | | | | | | | | | | | | | | | | | | | | | | | | | | | | | | | | | | | | | | | | | | | | | | | | | | | | | |
| Record: | At max. rate: | CO ppm | AND CO ₂ % | | | | | | | | | | | | | | | | | | | | | | | | | | | | | | | | | | | | | | | | | | | | | | | | | | | | | | | | | | | | | | | | | | | | | | |
| | At min. rate: (Where Possible) | CO ppm | AND CO ₂ % | | | | | | | | | | | | | | | | | | | | | | | | | | | | | | | | | | | | | | | | | | | | | | | | | | | | | | | | | | | | | | | | | | | | | | |
| Comments: | | | | | | | | | | | | | | | | | | | | | | | | | | | | | | | | | | | | | | | | | | | | | | | | | | | | | | | | | | | | | | | | | | | | | | | | | |
| Signature | | | | | | | | | | | | | | | | | | | | | | | | | | | | | | | | | | | | | | | | | | | | | | | | | | | | | | | | | | | | | | | | | | | | | | | | | |
| <table border="1" style="width: 100%; border-collapse: collapse;"> <tr> <td colspan="2">SERVICE 09</td> <td colspan="2">Date:</td> </tr> <tr> <td colspan="4">Engineer name:</td> </tr> <tr> <td colspan="4">Company name:</td> </tr> <tr> <td colspan="4">Telephone No:</td> </tr> <tr> <td colspan="4">Gas safe register No:</td> </tr> <tr> <td>Record:</td> <td>At max. rate:</td> <td>CO ppm</td> <td>AND CO₂ %</td> </tr> <tr> <td></td> <td>At min. rate: (Where Possible)</td> <td>CO ppm</td> <td>AND CO₂ %</td> </tr> <tr> <td colspan="4">Comments:</td> </tr> <tr> <td colspan="4">Signature</td> </tr> </table> | SERVICE 09 | | Date: | | Engineer name: | | | | Company name: | | | | Telephone No: | | | | Gas safe register No: | | | | Record: | At max. rate: | CO ppm | AND CO ₂ % | | At min. rate: (Where Possible) | CO ppm | AND CO ₂ % | Comments: | | | | Signature | | | | <table border="1" style="width: 100%; border-collapse: collapse;"> <tr> <td colspan="2">SERVICE 10</td> <td colspan="2">Date:</td> </tr> <tr> <td colspan="4">Engineer name:</td> </tr> <tr> <td colspan="4">Company name:</td> </tr> <tr> <td colspan="4">Telephone No:</td> </tr> <tr> <td colspan="4">Gas safe register No:</td> </tr> <tr> <td>Record:</td> <td>At max. rate:</td> <td>CO ppm</td> <td>AND CO₂ %</td> </tr> <tr> <td></td> <td>At min. rate: (Where Possible)</td> <td>CO ppm</td> <td>AND CO₂ %</td> </tr> <tr> <td colspan="4">Comments:</td> </tr> <tr> <td colspan="4">Signature</td> </tr> </table> | SERVICE 10 | | Date: | | Engineer name: | | | | Company name: | | | | Telephone No: | | | | Gas safe register No: | | | | Record: | At max. rate: | CO ppm | AND CO ₂ % | | At min. rate: (Where Possible) | CO ppm | AND CO ₂ % | Comments: | | | | Signature | | | |
| SERVICE 09 | | Date: | | | | | | | | | | | | | | | | | | | | | | | | | | | | | | | | | | | | | | | | | | | | | | | | | | | | | | | | | | | | | | | | | | | | | | | |
| Engineer name: | | | | | | | | | | | | | | | | | | | | | | | | | | | | | | | | | | | | | | | | | | | | | | | | | | | | | | | | | | | | | | | | | | | | | | | | | |
| Company name: | | | | | | | | | | | | | | | | | | | | | | | | | | | | | | | | | | | | | | | | | | | | | | | | | | | | | | | | | | | | | | | | | | | | | | | | | |
| Telephone No: | | | | | | | | | | | | | | | | | | | | | | | | | | | | | | | | | | | | | | | | | | | | | | | | | | | | | | | | | | | | | | | | | | | | | | | | | |
| Gas safe register No: | | | | | | | | | | | | | | | | | | | | | | | | | | | | | | | | | | | | | | | | | | | | | | | | | | | | | | | | | | | | | | | | | | | | | | | | | |
| Record: | At max. rate: | CO ppm | AND CO ₂ % | | | | | | | | | | | | | | | | | | | | | | | | | | | | | | | | | | | | | | | | | | | | | | | | | | | | | | | | | | | | | | | | | | | | | | |
| | At min. rate: (Where Possible) | CO ppm | AND CO ₂ % | | | | | | | | | | | | | | | | | | | | | | | | | | | | | | | | | | | | | | | | | | | | | | | | | | | | | | | | | | | | | | | | | | | | | | |
| Comments: | | | | | | | | | | | | | | | | | | | | | | | | | | | | | | | | | | | | | | | | | | | | | | | | | | | | | | | | | | | | | | | | | | | | | | | | | |
| Signature | | | | | | | | | | | | | | | | | | | | | | | | | | | | | | | | | | | | | | | | | | | | | | | | | | | | | | | | | | | | | | | | | | | | | | | | | |
| SERVICE 10 | | Date: | | | | | | | | | | | | | | | | | | | | | | | | | | | | | | | | | | | | | | | | | | | | | | | | | | | | | | | | | | | | | | | | | | | | | | | |
| Engineer name: | | | | | | | | | | | | | | | | | | | | | | | | | | | | | | | | | | | | | | | | | | | | | | | | | | | | | | | | | | | | | | | | | | | | | | | | | |
| Company name: | | | | | | | | | | | | | | | | | | | | | | | | | | | | | | | | | | | | | | | | | | | | | | | | | | | | | | | | | | | | | | | | | | | | | | | | | |
| Telephone No: | | | | | | | | | | | | | | | | | | | | | | | | | | | | | | | | | | | | | | | | | | | | | | | | | | | | | | | | | | | | | | | | | | | | | | | | | |
| Gas safe register No: | | | | | | | | | | | | | | | | | | | | | | | | | | | | | | | | | | | | | | | | | | | | | | | | | | | | | | | | | | | | | | | | | | | | | | | | | |
| Record: | At max. rate: | CO ppm | AND CO ₂ % | | | | | | | | | | | | | | | | | | | | | | | | | | | | | | | | | | | | | | | | | | | | | | | | | | | | | | | | | | | | | | | | | | | | | | |
| | At min. rate: (Where Possible) | CO ppm | AND CO ₂ % | | | | | | | | | | | | | | | | | | | | | | | | | | | | | | | | | | | | | | | | | | | | | | | | | | | | | | | | | | | | | | | | | | | | | | |
| Comments: | | | | | | | | | | | | | | | | | | | | | | | | | | | | | | | | | | | | | | | | | | | | | | | | | | | | | | | | | | | | | | | | | | | | | | | | | |
| Signature | | | | | | | | | | | | | | | | | | | | | | | | | | | | | | | | | | | | | | | | | | | | | | | | | | | | | | | | | | | | | | | | | | | | | | | | | |

*All installations in England and Wales must be notified to Local Authority Building Control (LABC) either directly or through a Competent Persons Scheme. A Building Regulations Compliance Certificate will then be issued to the customer.



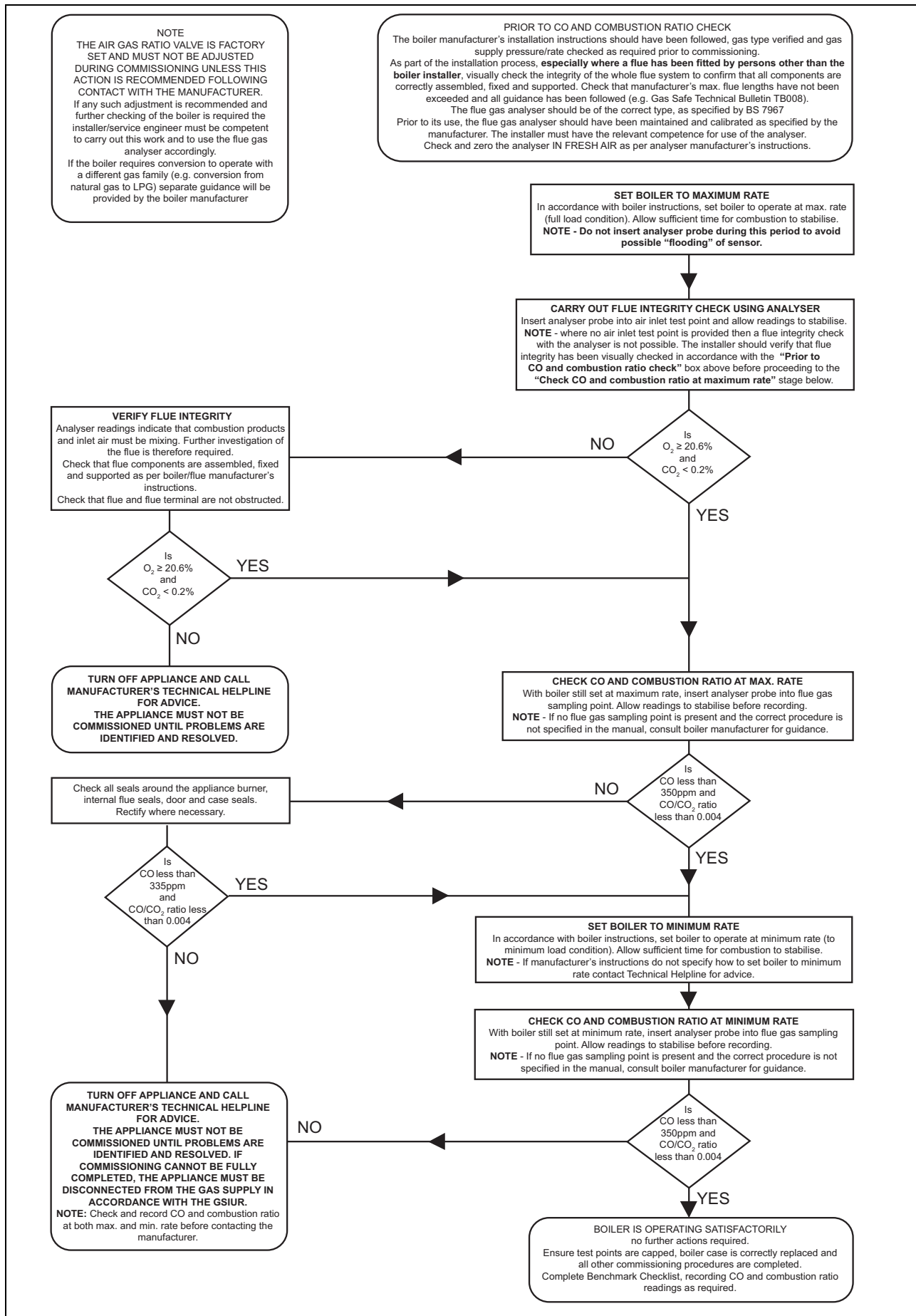

Appendix

H Position of the opening in the air/flue pipe

Applicability: Great Britain

OR Ireland

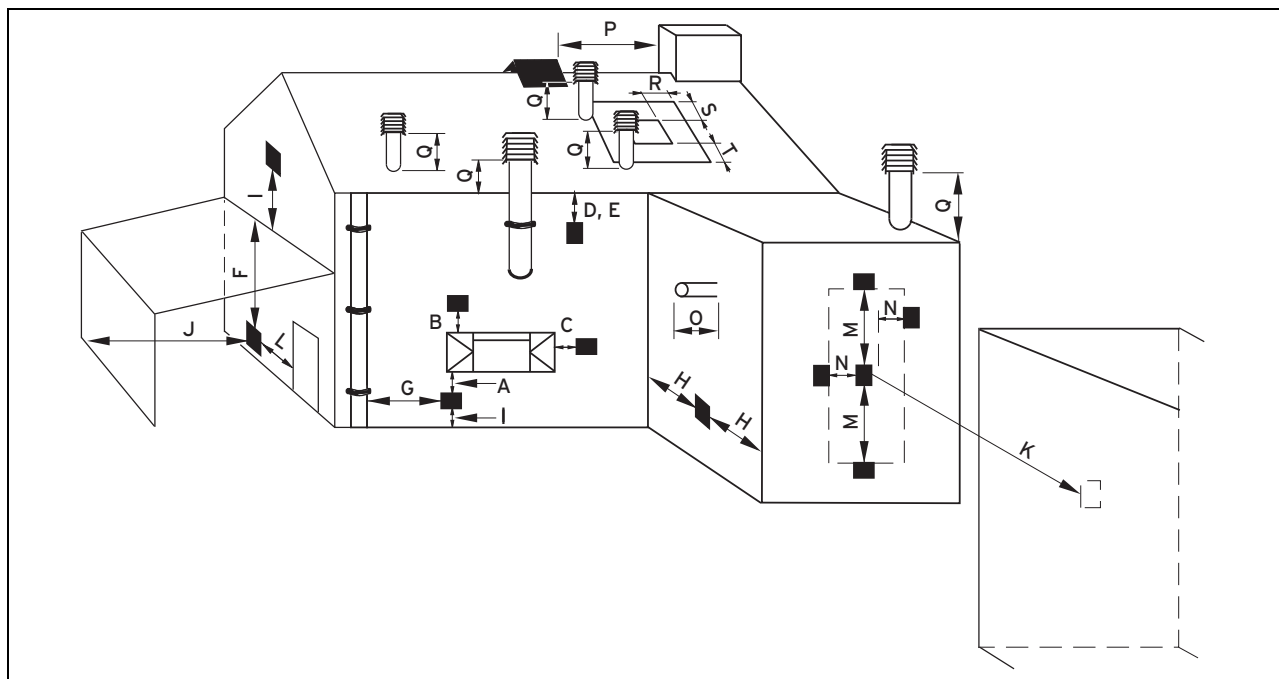

H.1 Positioning of the opening of a fan-supported flue gas pipe

Applicability: Great Britain

OR Ireland

| | Installation site | Minimum dimensions |
|---|-------------------------------------------------------------------------------------------------------|--------------------|
| A | Directly below an opening, air bricks, opening windows, etc., that can be opened. | 300 mm |
| B | Above an opening, air bricks, opening windows, etc., that can be opened. | 300 mm |
| C | Horizontally to an opening, air bricks, opening windows, etc., that can be opened. | 300 mm |
| D | Below temperature-sensitive building components, e.g. plastic gutters, down pipes or wastewater pipes | 75 mm |
| E | Below eaves | 200 mm |
| F | Below balconies or car port roofs | 200 mm |
| G | From vertical wastewater pipes or down pipes | 150 mm |
| H | From external or internal corners | 200 mm |
| I | Above floors, roofs or balconies | 300 mm |
| J | From a surface facing a terminal | 600 mm |
| K | From a terminal facing a terminal | 1,200 mm |
| L | From an opening in the car port (e.g. door, window) which leads into the dwelling | 1,200 mm |
| M | Vertical from a terminal on the same wall | 1,500 mm |
| N | Horizontal from a terminal on the same wall | 300 mm |
| O | From the wall on which the terminal has been installed | 0 mm |
| P | From a vertical structure on the roof | 300 mm |
| Q | Above the roof area | 300 mm |
| R | Horizontal from adjacent windows on pitched or flat roofs | 600 mm |
| S | Above adjacent windows on pitched or flat roofs | 600 mm |
| T | Below adjacent windows on pitched or flat roofs | 2,000 mm |

I Horizontal terminal positioning

Applicability: Great Britain

OR Ireland

BS 5440-1 recommends that fanned flue chimney terminals should be positioned as follows:

- at least 2 m from an opening in the building directly opposite, and
- so that the products of combustion are not directed to discharge directly across a boundary if the products are likely to cause a nuisance to a neighbour or discharge over a walkway or patio.

For IE see current issue of IS 813.

For boilers covered within this manual.

1) Dimensions D, E, F and G:

These clearances may be reduced to 25 mm without affecting the performance of the boiler. In order to ensure that the condensate plume does not affect adjacent surfaces the terminal should be extended as shown below.

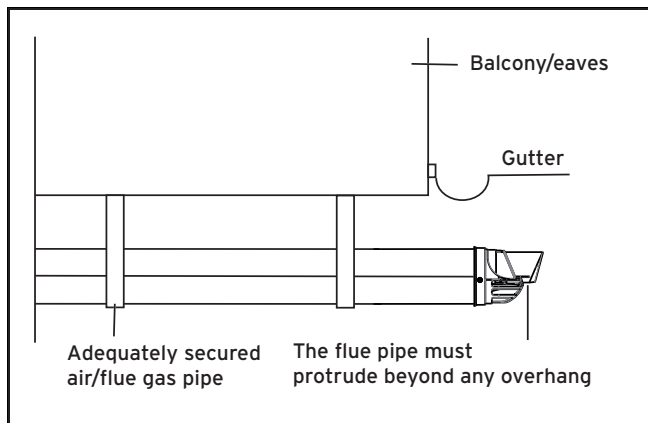

2) Dimension H:

This clearance may be reduced to 25 mm without affecting the performance of the boiler. However, in order to ensure that the condensate plume does not affect adjacent surfaces a clearance of 300 mm is preferred.

For 1 and 2 above you can use a flue gas management kit to enable the termination point to be positioned and directed away from the building fabric.

J Gas adjustment values

Set values, G20 natural gas

| | | VU 446/5-5 (H-GB) | VU 606/5-5 (H-GB) |
|-----------------------------------------------------------------------------------|----------------------------------|--------------------------|--------------------------|
| CO ₂ after 5 minutes in full load mode with front casing closed | Checking during start- up | 9.2 ± 1.0 vol. % | 9.2 ± 1.0 vol. % |
| | Checking after reset- ting | 9.2 ± 0.3 vol. % | 9.2 ± 0.3 vol. % |
| CO ₂ after 5 minutes in full load mode with front casing removed | Checking during start- up | 9.0 ± 1.0 vol. % | 9.0 ± 1.0 vol. % |
| | Checking after reset- ting | 9.0 ± 0.3 vol. % | 9.0 ± 0.3 vol. % |
| Set for Wobbe index W ₀ | | 14.1 kW·h/m ³ | 14.1 kW·h/m ³ |
| O ₂ after 5 minutes in full load mode with front casing closed | Checking during start- up | 4.5 ± 1.8 vol. % | 4.5 ± 1.8 vol. % |
| | Checking after reset- ting | 4.5 ± 0.5 vol. % | 4.5 ± 0.5 vol. % |

Appendix

Set values, G31 liquefied petroleum gas

| | | VU 446/5-5 (H-GB) | VU 606/5-5 (H-GB) |
|-----------------------------------------------------------------------------|--------------------------|--------------------------|--------------------------|
| CO ₂ after 5 minutes in full load mode with front casing closed | Checking during start-up | 9.9 ± 1.0 vol. % | 10.1 ± 1.0 vol. % |
| | Checking after resetting | 9.9 ± 0.3 vol. % | 10.1 ± 0.3 vol. % |
| CO ₂ after 5 minutes in full load mode with front casing removed | Checking during start-up | 9.7 ± 1.0 vol. % | 9.9 ± 1.0 vol. % |
| | Checking after resetting | 9.7 ± 0.3 vol. % | 9.9 ± 0.3 vol. % |
| Set for Wobbe index W ₀ | | 21.3 kW·h/m ³ | 21.3 kW·h/m ³ |
| O ₂ after 5 minutes in full load mode with front casing closed | Checking during start-up | 5.9 ± 1.8 vol. % | 5.5 ± 1.8 vol. % |
| | Checking after resetting | 5.9 ± 0.5 vol. % | 5.5 ± 0.5 vol. % |

K Technical data

Technical data – Heating

| | VU 446/5-5 (H-GB) | VU 606/5-5 (H-GB) |
|----------------------------------------------------------------------------------------|----------------------|----------------------|
| Maximum heating flow temperature (default setting – D.71) | 75 °C | 75 °C |
| Range for the heating flow temperature control | 30 ... 80 °C | 30 ... 80 °C |
| Maximum permissible pressure (PMS) | 0.4 MPa (4.0 bar) | 0.4 MPa (4.0 bar) |
| Safety discharge of expansion relief valve | 0.4 MPa (4.0 bar) | 0.4 MPa (4.0 bar) |
| Nominal water flow (ΔT = 20 K) | 1,900 l/h | 2,500 l/h |
| Approximate value for the condensate volume (pH value between 3.5 and 4.0) at 50/30 °C | 4.5 l/h | 5.6 l/h |
| Maximum heat output (factory setting – D.000) | Auto | Auto |

Technical data – Power/heat input (G20)

| | VU 446/5-5 (H-GB) | VU 606/5-5 (H-GB) |
|----------------------------------------|-------------------|-------------------|
| Effective output range (P) at 50/30 °C | 8.7 ... 48.0 kW | 12.2 ... 63.5 kW |
| Heat output range (P) at 60/40 °C | 8.5 ... 46.6 kW | 11.8 ... 61.7 kW |
| Effective output range (P) at 80/60 °C | 7.8 ... 44.1 kW | 11.0 ... 58.7 kW |
| Maximum heat input – heating (Q max.) | 45.2 kW | 60.0 kW |
| Minimum heat input – heating (Q min.) | 8.1 kW | 11.3 kW |

Technical data – Power/heat input (G31)

| | VU 446/5-5 (H-GB) | VU 606/5-5 (H-GB) |
|----------------------------------------|-------------------|-------------------|
| Effective output range (P) at 50/30 °C | 8.6 ... 46.6 kW | 12.0 ... 62.1 kW |
| Effective output range (P) at 80/60 °C | 7.8 ... 44.0 kW | 11.1 ... 58.4 kW |
| Maximum heat input – heating (Q max.) | 45.2 kW | 60.0 kW |
| Minimum heat input – heating (Q min.) | 8.1 kW | 11.3 kW |

Technical data – General

| | VU 446/5-5 (H-GB) | VU 606/5-5 (H-GB) |
|-----------------------------------------------------------------------|-------------------|-------------------|
| Gas category | II2H3P | II2H3P |
| Diameter of the gas pipe at the product outlet | 25 mm | 25 mm |
| Diameter at the outlet of the gas compression fitting, outside thread | 1" | 1" |

| | VU 446/5-5 (H-GB) | VU 606/5-5 (H-GB) |
|--------------------------------------------------------------------|--------------------------------------------------------------|--------------------------------------------------------------|
| Diameter at the outlet of the gas stopcock, inside thread | 1" | 1" |
| Diameter of the heating pipe at the product outlet, outside thread | 1 1/2" | 1 1/2" |
| Diameter at the outlet of the heating connection, outside thread | 1 1/2" | 1 1/2" |
| Diameter at the outlet of the heating stopcock, inside thread | 1 1/4" | 1 1/4" |
| Connection diameter of the expansion relief valve, inside thread | 1" | 1" |
| G20 gas supply pressure | 2.0 kPa (20.0 mbar) | 2.0 kPa (20.0 mbar) |
| G31 gas supply pressure | 3.7 kPa (37.0 mbar) | 3.7 kPa (37.0 mbar) |
| CE number (PIN) | CE-0063CS3428 | CE-0063CS3428 |
| Smoke mass flow in heating mode at P min. | 3.9 g/s | 5.3 g/s |
| Smoke mass flow in heating mode at P max. | 20.3 g/s | 27.0 g/s |
| Released system types | C13, C33, C43, C53, C93, B23, B23(P), B33, B53, B53(P) | C13, C33, C43, C53, C93, B23, B23(P), B33, B53, B53(P) |
| Flue gas temperature in heating mode (50/30 °C) at P min. | 37 °C | 37 °C |
| Flue gas temperature in heating mode at P max. 50/30 °C | 53 °C | 61 °C |
| Flue gas temperature in heating mode (80/60 °C) at P min. | 61 °C | 65 °C |
| Flue gas temperature in heating mode at P max. 80/60 °C | 78 °C | 78 °C |
| Nominal efficiency at 80/60 °C | 97.5 % | 97.8 % |
| Nominal efficiency at 50/30 °C | 106.2 % | 105.9 % |
| Nominal efficiency at 60/40 °C | 103.2 % | 102.8 % |
| Nominal efficiency in partial load mode (30%) at 40/30 °C | 109.1 % | 109.5 % |
| NOx class | 6 | 6 |
| Product dimensions, width | 440 mm | 440 mm |
| Product dimensions, depth | 405 mm | 473 mm |
| Product dimensions, height | 720 mm | 720 mm |
| Net weight | 37.8 kg | 47.2 kg |

Technical data – Electrics

| | VU 446/5-5 (H-GB) | VU 606/5-5 (H-GB) |
|--------------------------------------|--------------------|--------------------|
| Electric connection | – 230 V – 50 Hz | – 230 V – 50 Hz |
| Built-in fuse (slow-blow) | T4H/4A,250V | T4H/4A,250V |
| Maximum electrical power consumption | ≤ 162 W | ≤ 250 W |
| Standby electrical power consumption | 1.8 W | 1.8 W |
| IP rating | IPX4D | IPX4D |
| Permissible connected voltage | 195 ... 253 V | 195 ... 253 V |

Index

Index

A

| | |
|-------------------------------------|----|
| Additional relay | 24 |
| Air ratio setting | 27 |
| Air separation system, filter | 40 |
| Air/flue pipe | 18 |
| Air/flue pipe, installed | 5 |
| Appliance config. | 21 |
| Article number | 8 |

B

| | |
|-------------------------------------------|----|
| Basic diagram | 4 |
| Burner anti-cycling time | 29 |
| Burner anti-cycling time, remaining | 30 |

C

| | |
|----------------------------------------------------------------|-------|
| Calling up diagnostics codes | 29 |
| Carrying out inspection work | 36 |
| Carrying out maintenance work | 36 |
| CE marking | 8 |
| Check programmes | 25 |
| Checking the burner | 38 |
| Checking the CO ₂ content | 27 |
| Checking the components | 37 |
| Checking the pre-charge pressure of the expansion vessel | 40 |
| Cleaning the components | 37 |
| Cleaning the condensate siphon | 39 |
| Clearance | 10 |
| Combustion air supply | 5 |
| Comfort protection mode | 31 |
| Compact thermal module | 6, 37 |
| Competent person | 3 |
| Competent person telephone number | 24 |
| Completing cleaning work | 40 |
| Completing inspection work | 40–41 |
| Completing maintenance work | 41 |
| Completing repair work | 36 |
| Condensate discharge pipe | 18 |
| Condensate siphon | 23 |
| Connection dimensions | 9 |
| Control | 20 |
| Corrosion | 5 |
| Corrugated gas pipe | 6 |

D

| | |
|----------------------------------|----|
| Data plate | 7 |
| Disposal, packaging | 41 |
| Disposing of the packaging | 41 |
| Documents | 7 |
| Draining the product | 40 |

E

| | |
|------------------------------|----|
| Electricity | 4 |
| Electronics self-test | 37 |
| Expansion relief valve | 18 |

F

| | |
|--------------------------------------------------------|----|
| Factory settings for the parameters | 32 |
| Fault code | 31 |
| Fault memory | 32 |
| Filling the heating installation | 23 |
| Flow temperature, maximum | 31 |
| Flue gas route | 4 |
| Flue system | 19 |
| From the delivery point to the installation site | 9 |

| | |
|----------------------------|----|
| Front casing, closed | 5 |
| Frost | 5 |
| Function menu | 37 |

G

| | |
|----------------------|----|
| Gas connection | 16 |
| Gas setting | 25 |
| Gas type | 15 |

H

| | |
|------------------------------------|----|
| Handing over to the end user | 31 |
| Heat exchanger | 38 |
| Heating flow | 17 |
| Heating return | 17 |

I

| | |
|---------------------------------------------|-----|
| If you smell flue gas | 4 |
| If you smell gas | 3–4 |
| Installation assistant | 24 |
| Installation clearances | 10 |
| Installation site | 4–5 |
| Installer level | 21 |
| Installing the compact thermal module | 38 |
| Installing the front casing | 11 |
| Intended use | 3 |

L

| | |
|----------------------------|-------|
| Language | 24 |
| Leak detection spray | 6 |
| Leak-tightness | 28 |
| Liquid gas | 4, 15 |
| Live Monitor | 21 |

M

| | |
|-------------------------------|--------|
| Maintenance interval | 31 |
| Maximum heating output | 24, 29 |
| Minimum clearances | 10 |
| Mounting the product | 10 |
| Multi-functional module | 24 |

O

| | |
|----------------------------|----|
| Open-flued operation | 5 |
| Operating concept | 21 |

P

| | |
|----------------------------------------|----|
| Performing diagnostics | 32 |
| Permanently decommissioning | 41 |
| Power supply | 20 |
| Preparing the cleaning work | 37 |
| Preparing the inspection work | 37 |
| Preparing the repair work | 32 |
| Product dimensions | 9 |
| Pump mode | 30 |
| Pump overrun | 30 |
| Purging the heating installation | 24 |

Q

| | |
|---------------------|---|
| Qualification | 3 |
|---------------------|---|

R

| | |
|------------------------------------------------|----|
| Regulations | 6 |
| Replacing components | 32 |
| Replacing the burner | 32 |
| Replacing the fan | 32 |
| Replacing the gas valve assembly | 32 |
| Replacing the heat exchanger | 34 |
| Replacing the main PCB | 36 |
| Replacing the PCB for the user interface | 36 |
| Replacing the pressure sensor | 35 |
| Replacing the pump | 35 |
| Replacing the Venturi | 32 |

| | |
|--------------------------------------------|--------|
| Restarting the installation assistant..... | 24 |
| Return temperature control | 31 |
| S | |
| Safety device..... | 4 |
| Self-test for the components | 37 |
| Serial number | 8 |
| Service message..... | 31 |
| Service partner | 31 |
| Setting the CO ₂ content..... | 27 |
| Setting the pump curve | 30 |
| Setting the pump output | 30 |
| Side section, installing..... | 11 |
| Side section, removing..... | 11 |
| Spare parts..... | 32 |
| Status codes..... | 21, 45 |
| Switching on the product..... | 24 |
| T | |
| Tool | 5 |
| Transport | 5 |
| Transporting | 9 |
| Treating the heating water..... | 21 |
| U | |
| Unloading the cardboard box | 9 |
| Using test programmes | 21 |
| V | |
| Voltage | 4 |

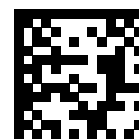

0020261389_02

0020261389_02 ■ 13.11.2018

Supplier

Vaillant Ltd.

Nottingham Road ■ Belper 111 Derbyshire 111 DE56 1JT

Telephone 0330 100 3461

info@vaillant.co.uk ■ www.vaillant.co.uk

Vaillant Group International GmbH

Berghauser Strasse 40 ■ 42859 Remscheid

Tel. +492191 18 0

www.vaillant.info

© These instructions, or parts thereof, are protected by copyright and may be reproduced or distributed only with the manufacturer's written consent.

Subject to technical modifications.