

INSTALLATION AND OPERATING INSTRUCTIONS

WALL HUNG RSF GAS CONDENSING INSTANTANEOUS WATER HEATER

GREENSPRING CWi47

FOR MAINS FED DOMESTIC HOT WATER

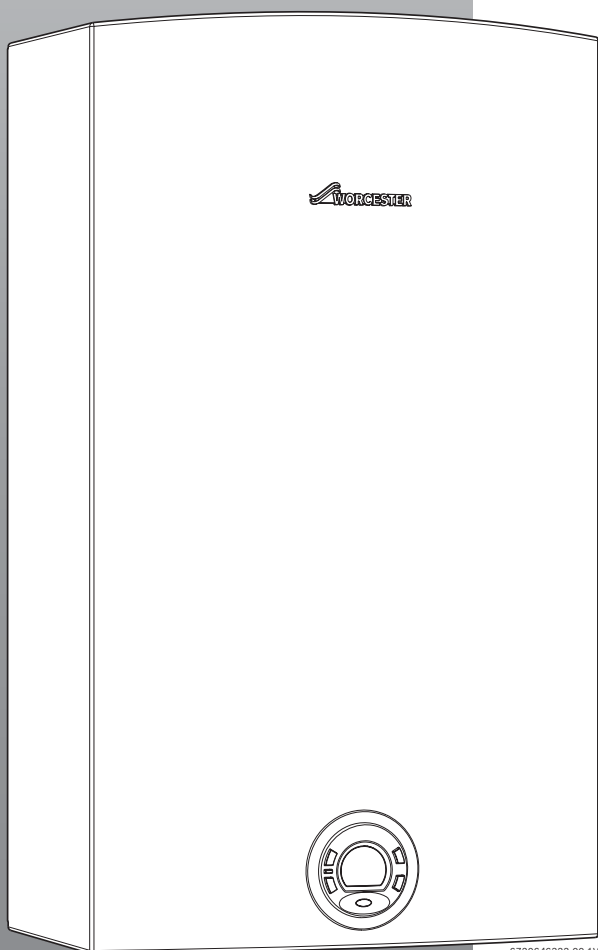

TABLE OF CONTENTS

1	KEY TO SYMBOLS AND SAFETY INSTRUCTIONS	3	7	FLUE OPTIONS	31
1.1	Explanation of symbols	3	7.1	FLUE accessories (diameter in mm)	31
1.2	Safety information	3			
2	Standards	5	8	Electrical connection	32
3	APPLIANCE INFORMATION	6	8.1	ELECTRICAL SUPPLY	32
3.1	Intended use	6	8.2	EQUIPOTENTIAL BONDING	32
3.2	Declaration of conformity with relevant EEC regulations	6	8.3	Connection	32
3.3	Explanation of Model Code	6	8.4	Power cable	32
3.4	Package contents	6	8.5	Position of the fuses in control unit	33
3.5	Description of the heater	6	8.6	Installation of Intelligent Cascading Kit	34
3.6	Optional accessories	6	8.7	Functional requirements FOR CASCADE SYSTEMS	35
3.7	Dimensions	7	9	Commissioning	36
3.8	LAYOUT	8	9.1	Factory regulations	36
3.9	CIRCUIT diagram	9	9.2	Measuring gas pressure	37
3.10	Technical data	10	9.3	Adjusting CO ₂ (carbon dioxide)	37
3.11	Operational instructions	11	9.4	Program values	40
4	Installations examples	12	9.5	Appliance cascading mode setting	41
4.1	Single unit without secondary return	12	9.6	Control board diagnostics	42
4.2	Single unit with secondary return	12	9.7	Fan speed adjustment	43
4.3	Multiple units without secondary return	13	9.8	Registration of remote control	44
4.4	Multiple units with secondary return	13	9.9	Remote control operation	44
5	Operating instructions	14	9.10	Program button	45
5.1	LCD Display	14	9.11	"Priority" function	45
5.2	Before operating the appliance	15	10	SERVICE AND SPARES	46
5.3	SWITCHING THE APPLIANCE ON OR OFF	15	10.1	Periodic maintenance tasks	46
5.4	Water temperature setting	15	10.2	Check the fuses in the control board	47
5.5	Operation	15	10.3	Condensing heat exchanger unit	48
5.6	DRAINING DOWN the appliance	16	10.4	Startup after maintenance	50
5.7	Reset button	16	11	FAULT FINDING AND DIAGNOSIS	51
5.8	Locked condition	16	11.1	FAULT FINDING	51
6	Installation instructions	17	12	HOT WATER FUNCTION	55
6.1	GAS SUPPLY	17	13	Environmental protection	56
6.2	APPLIANCE LOCATION AND CLEARANCES	17	14	Greenspring Water Heater GUARANTEE	57
6.3	Minimum CLEARANCES	18			
6.4	Installation of fixing bracket	18			
6.5	Installation	18			
6.6	Water connection	20			
6.7	CONDENSATE PIPE WORK	20			
6.8	Gas connection	24			
6.9	FLUE OPTIONS	25			
6.10	Flue installation	27			
6.11	Filling the condensate trap	30			

1 KEY TO SYMBOLS AND SAFETY INSTRUCTIONS

1.1 EXPLANATION OF SYMBOLS

WARNING SYMBOLS

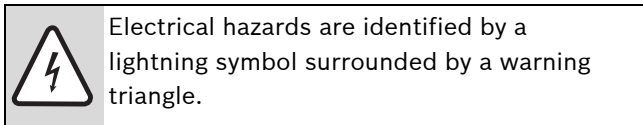
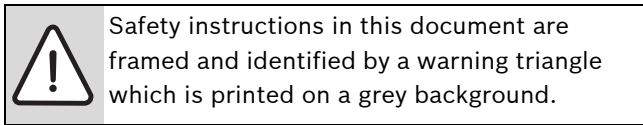

Signal words indicate the seriousness of the hazard in terms of the consequences of not following the safety instructions.

- **NOTICE** indicates possible damage to property or equipment, but where there is no risk of injury.
- **CAUTION** indicates possible injury.
- **WARNING** indicates possible severe injury.
- **DANGER** indicates possible risk to life.

IMPORTANT INFORMATION

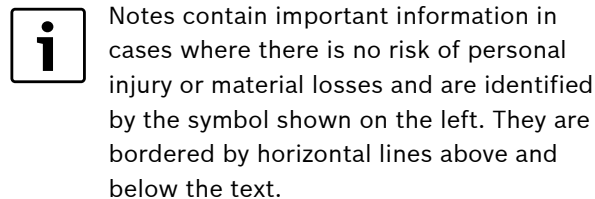

ADDITIONAL SYMBOLS

Symbol	Meaning
▶	a step in an action sequence
→	a reference to a related part in the document or to other related documents
•	a list entry
–	a list entry (second level)

Tab. 1

1.2 SAFETY INFORMATION

PLEASE READ THESE INSTRUCTIONS CAREFULLY BEFORE STARTING INSTALLATION.

THESE INSTRUCTIONS ARE APPLICABLE TO THE WORCESTER APPLIANCE MODEL(S) STATED ON THE FRONT COVER OF THIS MANUAL ONLY AND MUST NOT BE USED WITH ANY OTHER MAKE OR MODEL OF APPLIANCE.

THE INSTRUCTIONS APPLY IN THE UK AND IRELAND ONLY AND MUST BE FOLLOWED EXCEPT FOR ANY STATUTORY OBLIGATION.

THIS APPLIANCE MUST BE INSTALLED BY A GAS SAFE REGISTERED, COMPETENT PERSON. FAILURE TO INSTALL CORRECTLY COULD LEAD TO PROSECUTION. IF YOU ARE IN ANY DOUBT CONTACT THE WORCESTER TECHNICAL HELPLINE (0844 693 3028).

DISTANCE LEARNING AND TRAINING COURSES ARE AVAILABLE FROM WORCESTER.

PLEASE LEAVE THESE INSTRUCTIONS WITH THE COMPLETED COMMISSIONING CHECKLIST, (OR A CERTIFICATE CONFIRMING COMPLIANCE WITH EITHER I.S.813 (Domestic Gas Installation) OR I.S.820 (Non-Domestic Gas Installation) for, EIRE ONLY) AND THE USER MANUAL WITH THE OWNER OR AT THE GAS METER AFTER INSTALLATION OR SERVICING.

THE CHECKLIST CAN BE FOUND IN THE BACK PAGES OF THE INSTALLATION MANUAL. ABBREVIATIONS USED IN THIS MANUAL:

IF YOU SMELL GAS:

- ▶ **CALL** NATIONAL GAS EMERGENCY SERVICE ON 0800 111 999 (UK only).
- ▶ LPG WATER HEATERS CALL THE SUPPLIER'S NUMBER ON THE SIDE OF THE LPG TANK.
- ▶ **TURN OFF** THE ECV (EMERGENCY CONTROL VALVE) AT THE METER/REGULATOR.
- ▶ **DO NOT TURN** ELECTRICAL SWITCHES ON OR OFF
- ▶ **DO NOT** STRIKE MATCHES OR SMOKE AND PUT OUT NAKED FLAMES
- ▶ **OPEN** DOORS AND WINDOWS
- ▶ **KEEP** PEOPLE AWAY FROM THE AFFECTED AREA

WATER HEATER OPERATION:

This heater must only be operated by a responsible adult who has been instructed in, understands, and is aware of the heater's operating conditions and effects.

HEALTH AND SAFETY

The appliance contains no asbestos and no substances have been used in the construction process that contravene the COSHH Regulations (Control of Substances Hazardous to Health Regulations 1988).

COMBUSTION AND CORROSIVE MATERIALS

Do not store or use any combustible materials (paper, thinners, paints, propellant, cleaning agents etc.) inside or within the vicinity of the appliance or ventilation grill. Chemically aggressive substances can corrode the appliance and invalidate any warranty.

IMPORTANT INFORMATION

- ▶ Read installation manual prior to installation of this unit!
- ▶ Read user manual before putting this unit in operation!
- ▶ Observe the warnings in the manuals!
The installation room must fulfill the ventilation requirements!
- ▶ Installation by an authorised person only!



FITTING AND MODIFICATIONS

Fitting the appliance and any controls to the appliance may only be carried out by a competent engineer in accordance with the current Gas Safety (Installation and Use) Regulations.

Flue systems must not be modified in any way other than as described in the fitting instructions. Any misuse or unauthorised modifications to the appliance, flue or associated components and systems could invalidate the warranty. The manufacturer accepts no liability arising from any such actions, excluding statutory rights.

SERVICING

Advise the user to have the system serviced annually by a competent, qualified and registered Gas engineer. Approved spares must be used to help maintain the economy, safety and reliability of the appliance.

IMPORTANT

The service engineer must complete the Service Record on the Service Checklist after each service.

INSTALLATION REGULATIONS

Current Gas Safety (Installation & Use) Regulations: All gas appliances must be installed by a competent person in accordance with the above regulations. Failure to install appliances correctly could lead to prosecution. The appliance must be installed in accordance with, and comply to, the current: Gas Safety Regulations, IEE Regulations, Building Regulations, Building Standards (Scotland) (Consolidation), Building Regulations (Northern Ireland), local water by-laws, Health & Safety Document 635 (The Electricity at Work Regulations 1989) and any other local requirements.

2 STANDARDS

BRITISH STANDARDS:

Where no specific instruction is given, reference should be made to the relevant British Standard codes of Practice.

BS7074:1 Code of practice for domestic and hot water supply

BS6891 Installation of low pressure gas pipe work up to 28mm (R1)

BS5546 Installation of gas hot water supplies for domestic purposes

EN12828 Central heating for domestic premises

BS5440:1 Flues and ventilation for gas appliances of rated heating not exceeding 70kW (net):

Flues

BS5440:2 Flues and ventilation for gas appliances of rated heating not exceeding 70 kW (net) : Air Supply

BS6798 Installation of gas fired boilers of rated input up to 70kW (net)

BS EN 13076:2003 Devices to prevent pollution by backflow of potable water. Unrestricted air gap.

Family A. Type A

BS EN 13077:2008 Devices to prevent pollution by backflow of potable water. Air gap with non-circular overflow (unrestricted). Family A. Type B

BS EN 14623:2005 Devices to prevent pollution by backflow of potable water. Air gaps with minimum circular overflow (verified by test or measurement).

Family A, type G

BS6283-4:1991 Safety and control devices for use in hot water systems. Specification for drop-tight pressure reducing valves of nominal size up to and including DN 50 for supply pressures up to and including 12 bar.

CP342-2: 1974 Code of practice for centralised hot water supply. Buildings other than individual dwellings.

INSTALLATIONS OF A RATED INPUT GREATER THAN 70 KW:

BS6644 Specification for Installation of gas-fired hot water boilers of rated inputs between 70 kW (net) and 1.8 MW (net) (2nd and 3rd family gases).

BSEN15417:2006 Gas-fired central heating boilers. specific requirements for condensing boilers with a nominal heat input greater than 70 kW but not exceeding 1000 kW.

BSEN15420 Gas-fired central heating boilers. Type C boilers of nominal heat input exceeding 70 kW, but not exceeding 1000 kW.

IGE/UP/2 Gas installation pipework and compressors on industrial and commercial premises.

IGE/UP/10 Installation of gas appliances in industrial and commercial premises, part 1: flued appliances.

IRISH STANDARDS

The relevant Irish standards should be followed, including:

- ECTI National rules for electrical installations
- IS 813:2002 for Domestic Gas Installations.
- IS 820:2000 for Non-Domestic Gas Installations.

LPG INSTALLATIONS

An appliance using L.P.G. must not be installed a room or internal space below ground level unless one side of the building is open to the ground.

BS5482 Code of practice for domestic butane and propane gas burning installations. Installations at permanent dwellings, residential park homes and commercial premises, with installation pipework sizes not exceeding DN 25 for steel and DN 28 for corrugated stainless steel or copper.

TIMBER FRAMED BUILDING:

Where the heater is to be fitted to a timber framed building the guidelines laid down in BS5440: Part 1 and IGE/UP/7 should be adhered to.

POTABLE WATER:

All seals, joints and compounds (including flux and solder) and components used as part of the secondary domestic water system must be approved by WRAS.

3 APPLIANCE INFORMATION

3.1 INTENDED USE

The device should only be used to produce hot water for domestic or commercial uses.

3.2 DECLARATION OF CONFORMITY WITH RELEVANT EEC REGULATIONS

This appliance fulfills European directive requirements 90/396/EEC, 92/42/EEC, 73/23/EEC, 89/336/EEC and corresponds to the specifications described in the corresponding EEC certificate of proof.

Models	WTD 27 AM E23 S0505 WTD 27 AM E31 S0505
Category	II ₂ H3P
Type	B ₂₃ , C ₁₃ , C ₃₃ , C ₄₃ , C ₅₃ , C ₈₃

Tab. 2

3.3 EXPLANATION OF MODEL CODE

WTD 27	A	M	E	23 31	S..
---------------	---	---	---	----------	-----

Tab. 3

W	Gas water heater
T	Thermostatic
D	LCD
27	Capacity (Liter per minute)
A	Room sealed box
M	Fan assisted
E	Electric ignition
23	Appliance adjusted for natural gas
31	Appliance adjusted for LPG
S	Country code (S0505 - UK/IE)

3.4 PACKAGE CONTENTS

- Instantaneous Water Heater
- Fixing kit
- Documentation
- Gas Isolation Valve
- Water Inlet Isolation Valve with in-line filter
- Water connection pipes (2 off)
- Flue gasket

3.5 DESCRIPTION OF THE HEATER

- Water heater for wall-mounting
- High output pre-mix compact burner with low NOx emissions

- Modulating fan with constant gas:air ratio control
- LCD panel with back light
- Real time fault diagnostics
- Fault codes for easy diagnostics and repair
- Electronic ignition
- Modulating water valve:
 - Cold water temperature sensor
 - Water flow sensor
- Hot water temperature sensor
- Built in frost protection
- Safety devices:
 - Flame failure device (ionization flame sensor)
 - Flue gas recirculation temperature sensor
 - Inlet temperature sensor
 - Outlet temperature sensor
 - Flue gas overheat sensor
 - Heat exchanger overheat sensor
- Power supply: 230 V, 50 Hz
- IP X4 (protection against water drops)

3.6 OPTIONAL ACCESSORIES

- Cascading kit
 - Part number: 7 736 500 272
- Wireless remote control (Master)
 - Part number: 7 736 500 569
- Wireless remote control (Additional)
 - Part number: 7 736 500 699

3.7 DIMENSIONS

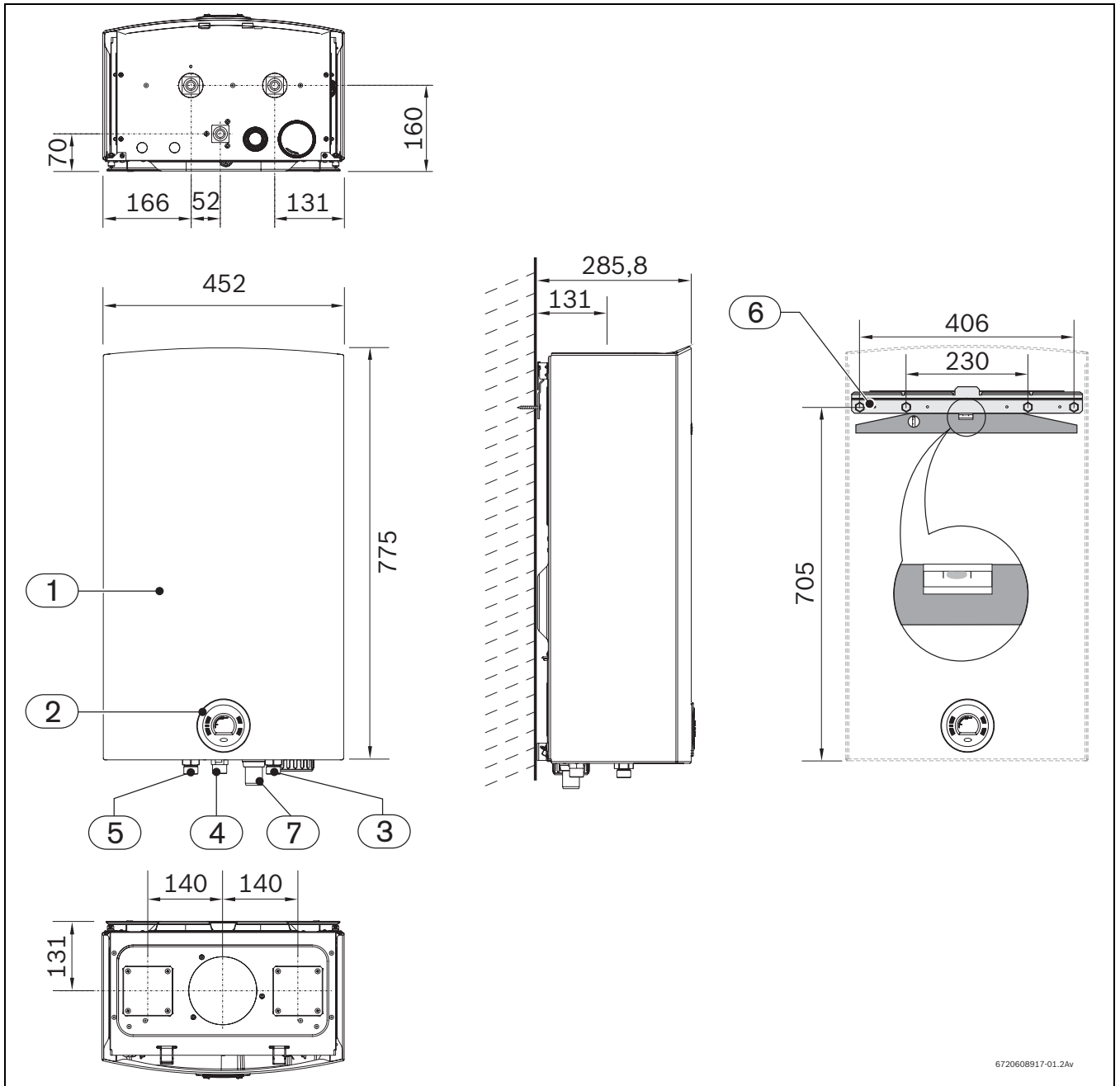

Fig. 1

- 1 Front cover
- 2 Controller
- 3 Cold water inlet: Ø 3/4" (supplied loose with 22mm copper pipe with 3/4" connection nut and a 22mm isolation valve incorporating filter)
- 4 Gas connection: Ø 3/4" (isolating valve supplied loose)
- 5 Hot water outlet: Ø 3/4" (supplied loose with 22mm copper pipe with 3/4" connection nut)
- 6 Wall mounting bracket
- 7 Condensate outlet Ø 32mm

3.8 LAYOUT

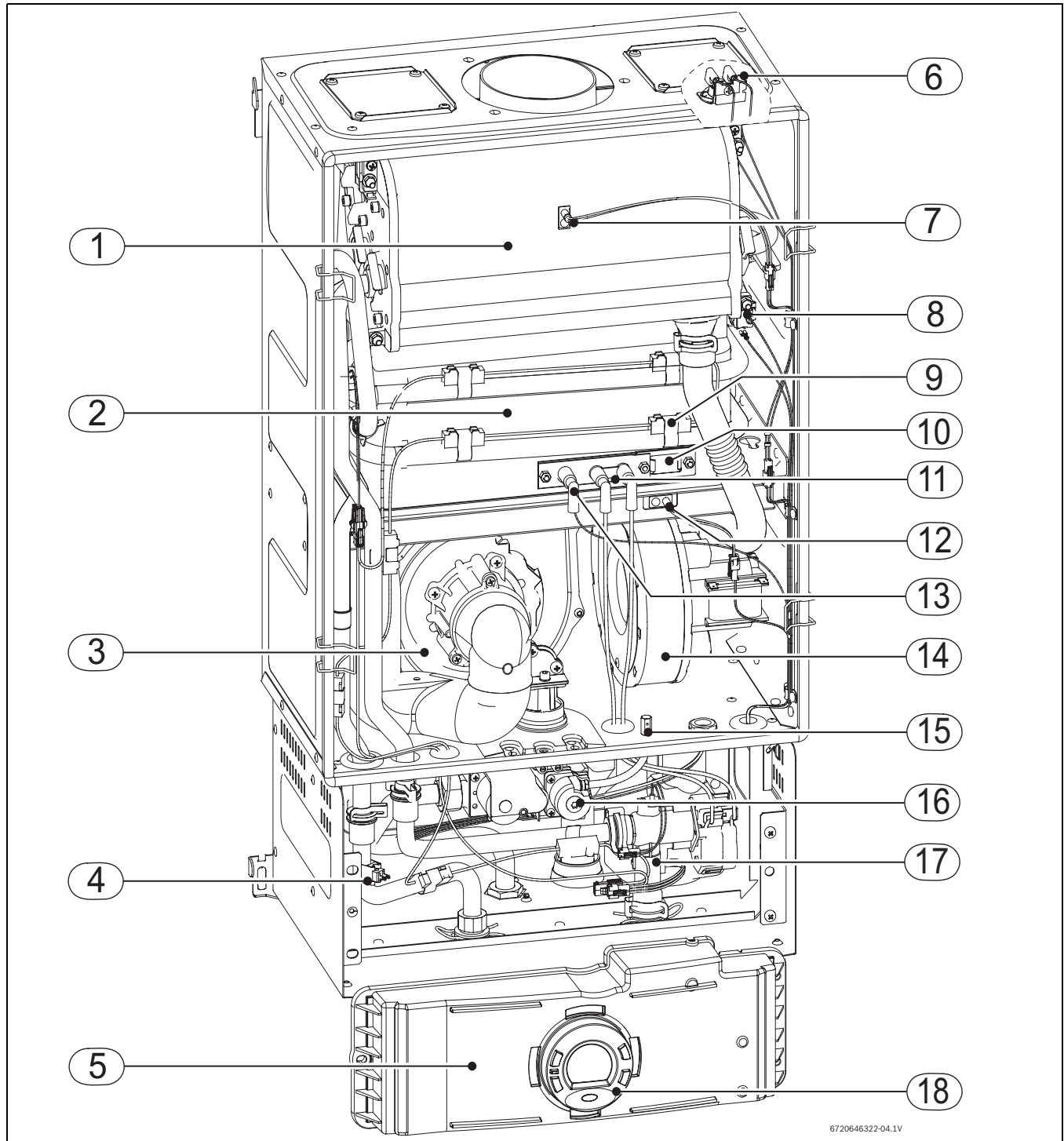

Fig. 2

- | | | | |
|-----------|---------------------------------------|-----------|--|
| 1 | Condensing heat exchanger | 13 | Ionization sensor |
| 2 | Heat exchanger | 14 | Secondary fan |
| 3 | Primary fan | 15 | Pressure test point gas valve |
| 4 | Hot water temperature sensor | 16 | Gas valve |
| 5 | Control unit | 17 | Water valve with flow sensor and cold water temperature sensor |
| 6 | Flue gas overheat sensor | 18 | Controller with LCD display |
| 7 | Flue gas temperature sensor | | |
| 8 | Heat exchanger overheat thermostat | | |
| 9 | Frost protection | | |
| 10 | Sight glass | | |
| 11 | Ignition electrodes | | |
| 12 | Flue recirculation temperature sensor | | |

3.9 CIRCUIT DIAGRAM

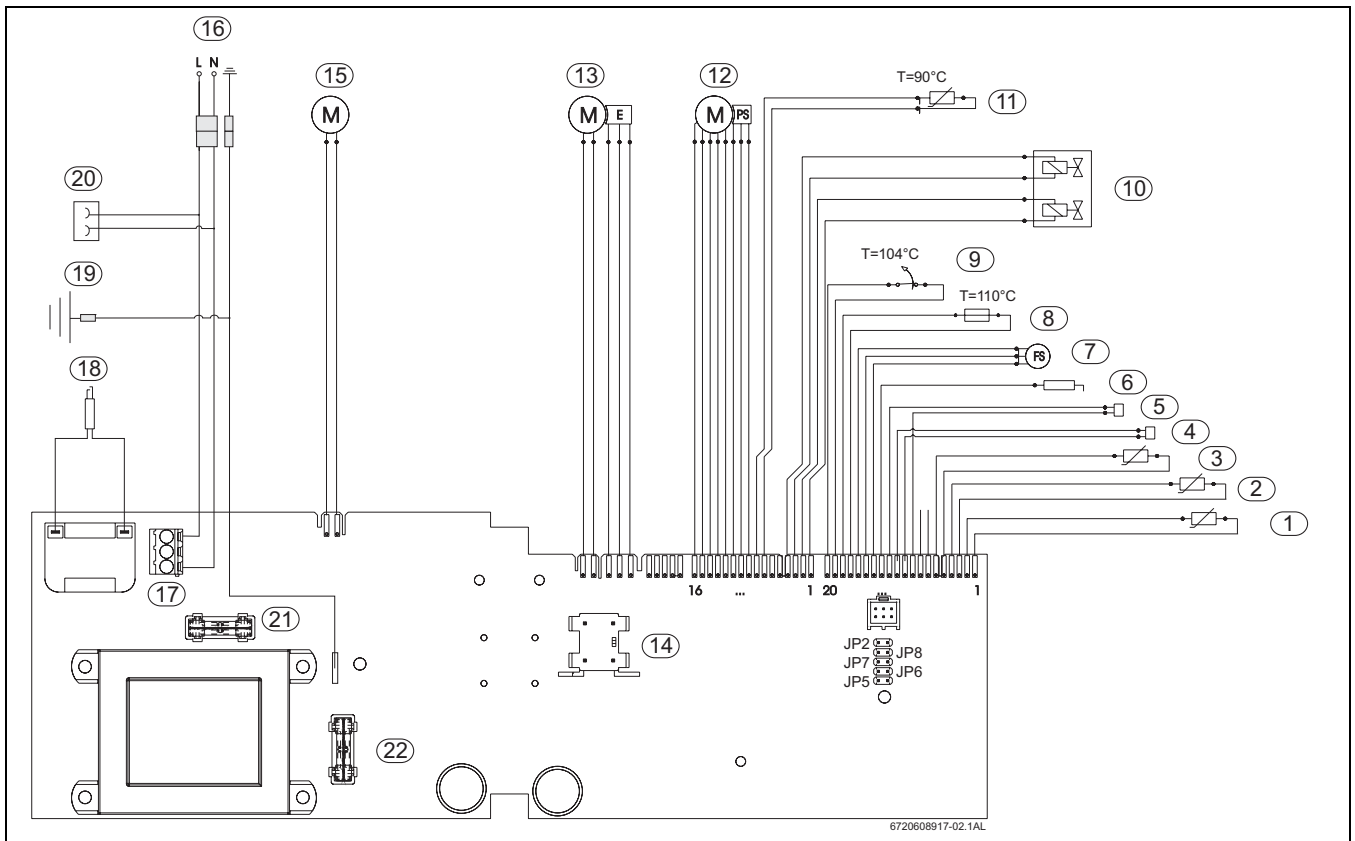

Fig. 3 Electrical scheme

- 1 Inlet water temperature sensor
- 2 Outlet water temperature sensor
- 3 Flue gas recirculation temperature sensor
- 4 Cascade kit output connection
- 5 Cascade kit input connection
- 6 Ionization sensor
- 7 Water flow sensor
- 8 Flue gas overheat sensor
- 9 Heat exchanger overheat thermostat (104°C)
- 10 Gas valve
- 11 Flue gas temperature sensor
- 12 Water valve
- 13 Primary fan
- 14 ON/OFF switch
- 15 Secondary fan
- 16 Power supply cable
- 17 Mains power connection terminal
- 18 Ignition electrodes
- 19 Earth bonding
- 20 Frost protection connection
- 21 Fuse (2,5A)
- 22 Fuse (1,6A)

3.10 TECHNICAL DATA

Technical characteristics	Symbol	Units	CWi47
Power and flow			
Nominal output	Pn	kW	50.3
Minimum output	Pmin	kW	6
Output (adjustment range)			6 - 50.3
Nominal input	Qn	kW	48.4
Minimum input	Qmin	kW	6
Gas data			
Supply pressure			
Natural gas	G20	mbar	20
LPG (propane)	G31	mbar	37
Gas consumption			
Natural gas (Hi = 9,5 kWh/m ³)	G20	m ³ /h	5.09
LPG (propane) (Hi = 12,8 kWh/kg)	G31	kg/h	3.8
Water data			
Maximum permissible pressure	pw	bar	12
Minimum operating pressure	pwmin	bar	0.3
Minimum activation flow		l/min	1.9
Maximum water flow with temperature rise of 35°C		l/min	20.6
Minimum water pressure for maximum water flow		bar	2.5
Combustion products			
Flue gas flow			
Natural gas		kg/h	81.8
LPG - Propane		kg/h	79.3
Temperature of combustion gases			
Flue gas temperature at maximum output		°C	60 - 70
Flue gas temperature at minimum output		°C	29
General Data			
Efficiency at nominal input		%	104
Voltage		V	230
Frequency		Hz	50
Maximum electrical power consumption		W	116
Type of protection		IP	X4D
Ambient temperature permitted		°C	0 - 50
NET efficiency		%	104
Weight (excluding packaging)		kg	34

Tab. 4

3.11 OPERATIONAL INSTRUCTIONS

HOT WATER

Open the gas and water valves and ensure that all joints are tight.

Place the on-off switch (Fig. 8, pos. 1) in the operating position (chapter 5.3), so that the appliance is ready for use.

When a hot water tap is opened, the water flow sensor will send a signal to the control unit. This signal initiates the following:

- The fan starts.
- Spark generator provides a spark at the burner and then the gas valve opens.
- The burner ignites.
- The ionisation electrode ensures the flame is present.
- The water temperature is controlled automatically by the sensors/controllers according to the temperature selected.

SAFETY CUT-OFF WHEN SAFETY PERIOD IS SURPASSED

The appliance attempts three starts before it safety circuit locks out. A single start attempt lasts 5 seconds followed by a 5 second break before having a new attempt. The start up cycle will last a maximum of 35 seconds before the appliance locks out on flame failure.

In this case, if the attempts to ignite go on too long, the security mechanisms prevent operation.

SAFETY CUT-OFF DUE TO EXCESSIVE WATER HEATING

The control unit detects the water temperature via a NTC sensor located in the hot water flow pipe and the temperature sensor located in the heat exchanger. If it detects an excessive temperature it provokes a safety cut-off.

RESTARTING AFTER SAFETY CUT-OFF

To restart the appliance following a safety cut-off:

- ▶ Press the reset key (Fig. 8, pos. 2).

4 INSTALLATIONS EXAMPLES

4.1 SINGLE UNIT WITHOUT SECONDARY RETURN

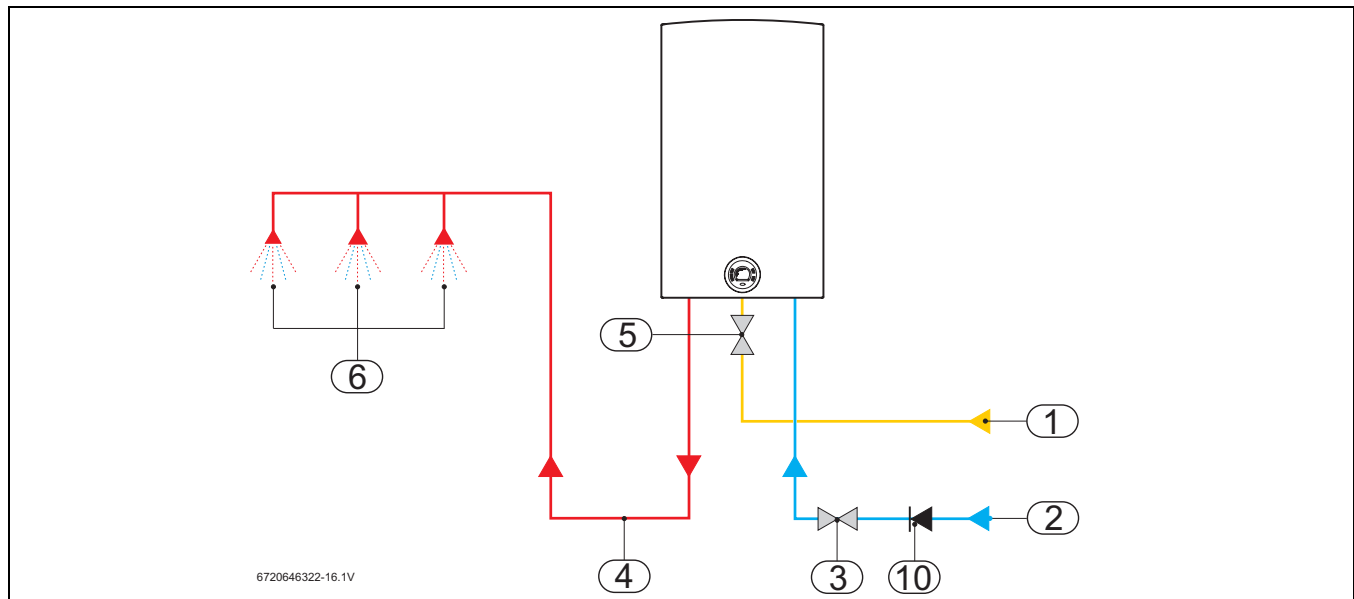

Fig. 4

- | | | | |
|---|---|----|---|
| 1 | Gas supply | 5 | Gas isolation valve (supplied with appliance) |
| 2 | Cold mains inlet | 6 | DHW outlets |
| 3 | Water isolation valve (supplied with appliance) | 10 | Non return valve |
| 4 | DHW flow | | |

4.2 SINGLE UNIT WITH SECONDARY RETURN

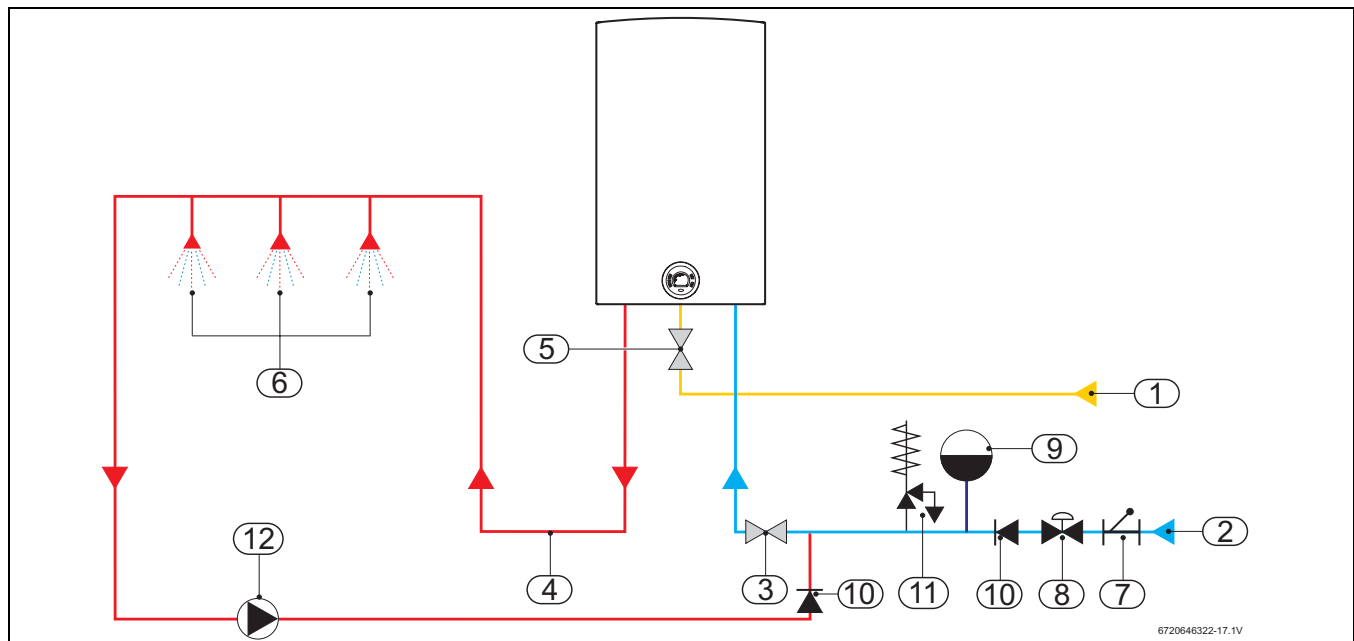

Fig. 5

- | | | | |
|---|---|----|----------------------------|
| 1 | Gas supply | 9 | Expansion vessel |
| 2 | Cold mains inlet | 10 | Non return valve |
| 3 | Water isolation valve (supplied with appliance) | 11 | Pressure relief valve |
| 4 | DHW flow | 12 | Secondary circulation pump |
| 5 | Gas isolation valve (supplied with appliance) | | |
| 6 | DHW outlets | | |
| 7 | Strainer | | |
| 8 | Pressure reducing valve | | |

4.3 MULTIPLE UNITS WITHOUT SECONDARY RETURN

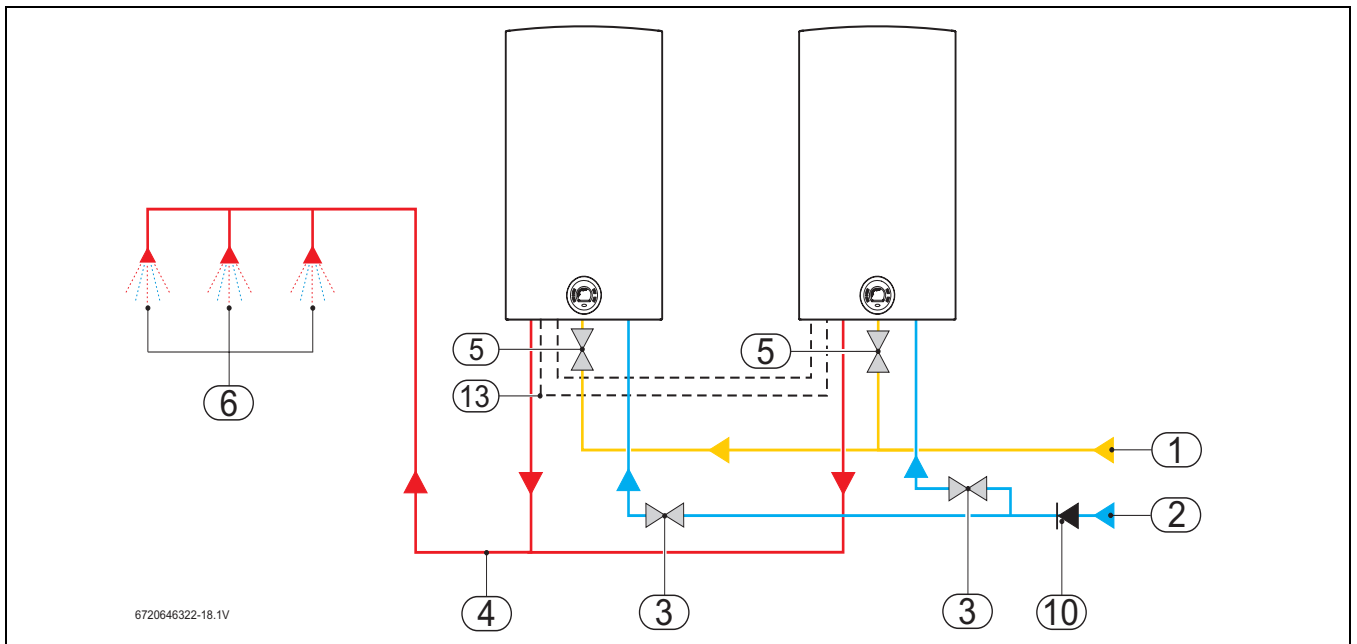

Fig. 6

- | | | | |
|---|---|----|---|
| 1 | Gas supply | 5 | Gas isolation valve (supplied with appliance) |
| 2 | Cold mains inlet | 6 | DHW outlets |
| 3 | Water isolation valve (supplied with appliance) | 10 | Non return valve |
| 4 | DHW flow | 13 | Cascading kit (part number 7 736 500 272) |

4.4 MULTIPLE UNITS WITH SECONDARY RETURN

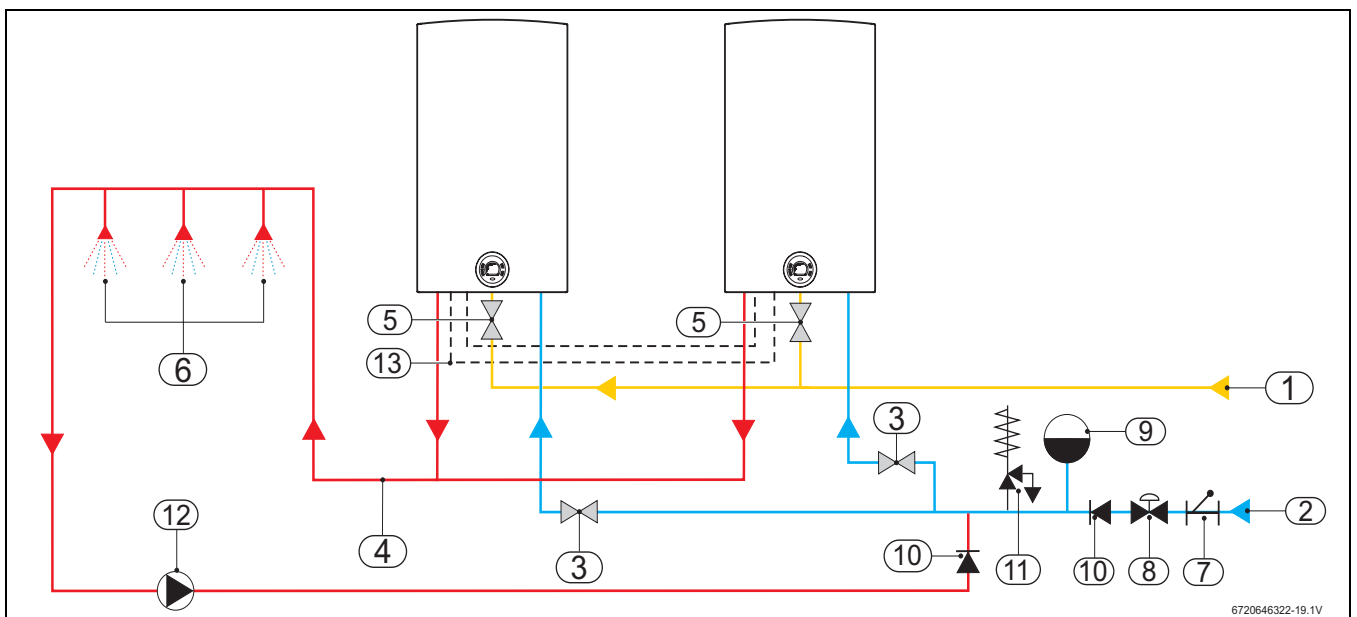

Fig. 7

- | | | | |
|----|---|----|---|
| 1 | Gas supply | 11 | Pressure relief valve |
| 2 | Cold mains inlet | 12 | Secondary circulation pump |
| 3 | Water isolation valve (supplied with appliance) | 13 | Cascading kit (part number 7 736 500 272) |
| 4 | DHW flow | | |
| 5 | Gas isolation valve (supplied with appliance) | | |
| 6 | DHW outlets | | |
| 7 | Strainer | | |
| 8 | Pressure reducing valve | | |
| 9 | Expansion vessel | | |
| 10 | Non return valve | | |

5 OPERATING INSTRUCTIONS

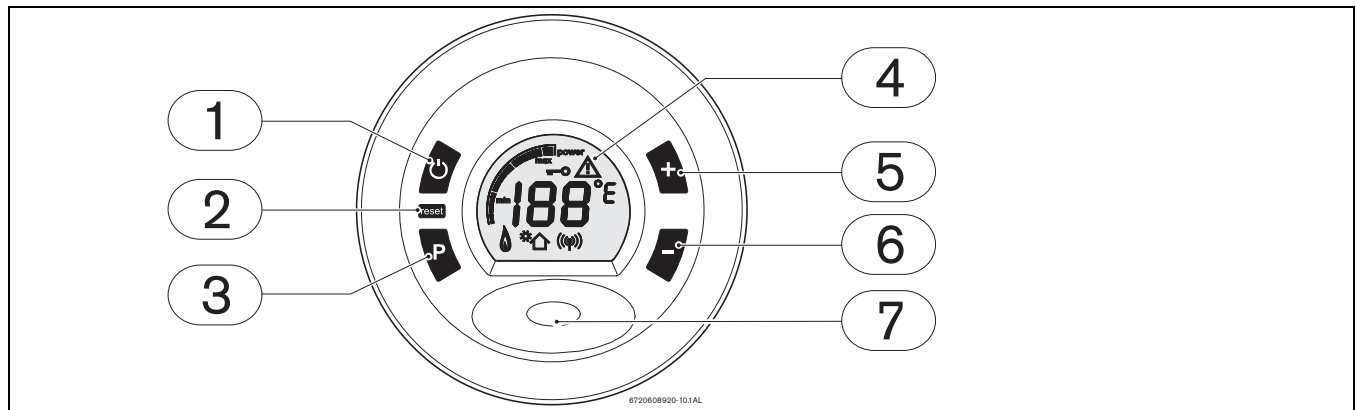

Fig. 8

- 1 Main ON/OFF button
- 2 Reset button
- 3 Program button
- 4 LCD display
- 5 Temperature increase key/ programming button
- 6 Temperature decrease key / programming button
- 7 LED

5.1 LCD DISPLAY



Do not use any aggressive cleaning agents to clean the display.

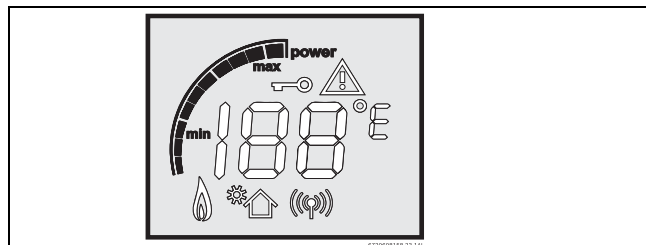

Fig. 9 Power bar indicator (input)

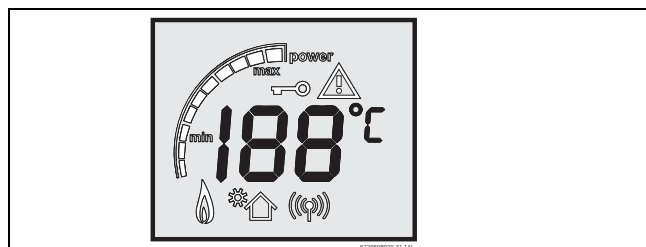

Fig. 10 Temperature indicator

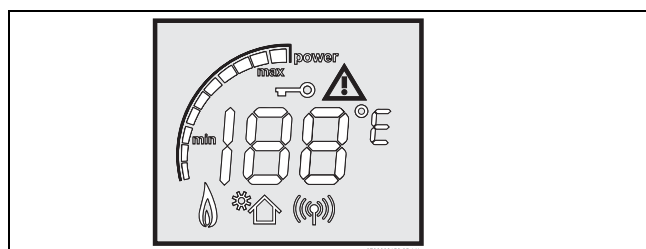

Fig. 11 Error indicator

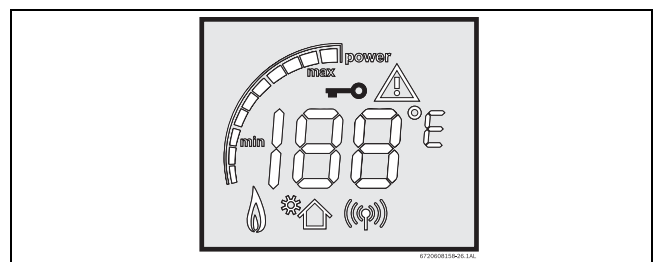

Fig. 12 Locked condition indicator (only with remote control)

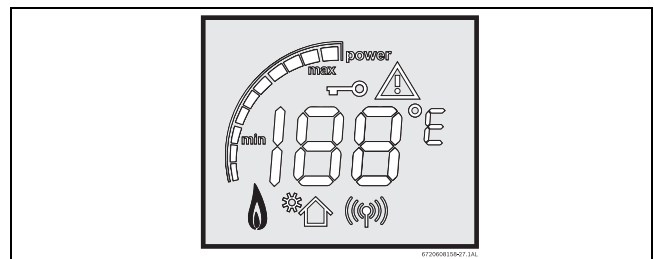

Fig. 13 Flame indicator

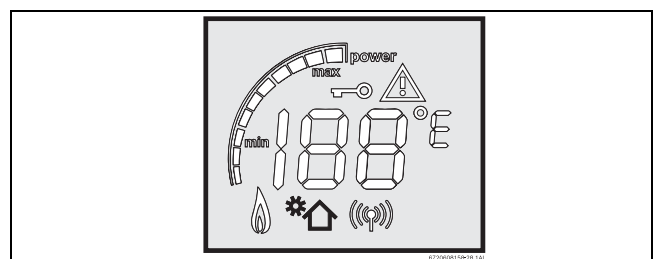

Fig. 14 Solar mode indicator

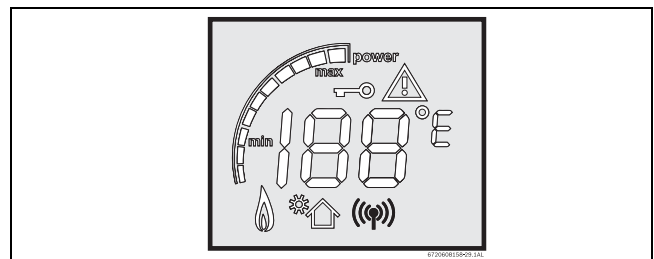

Fig. 15 Remote control indicator

5.2 BEFORE OPERATING THE APPLIANCE



CAUTION:

- ▶ The initial startup of the water heater must be carried out by a qualified and registered gas installer, who will provide the client with all the information necessary for its correct operation.

- ▶ Confirm that the gas type of the heater matches the gas supply you will be connecting the water heater.
- ▶ Open gas isolating valve.



Check all joints for gas leaks.

- ▶ Open water isolating valve.



Check all joints for water leaks.

5.3 SWITCHING THE APPLIANCE ON OR OFF

CONNECT

- ▶ To start the appliance press the On/Off button.

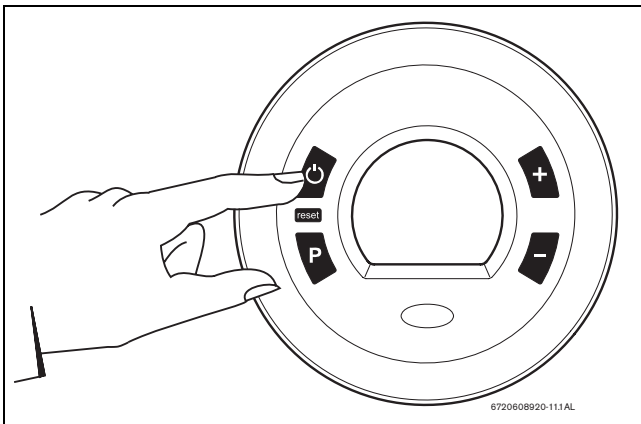

Fig. 16

SWITCHING OFF

- ▶ To switch off the appliance press the On/Off button again.

5.4 WATER TEMPERATURE SETTING



The temperature value indicated on the LCD panel corresponds to the temperature taken as the water leaves the appliance.

Factory default temperature set point: 42 °C.

To regulate the water temperature:

- ▶ Press the **+** or **-** buttons until the desired value is set.

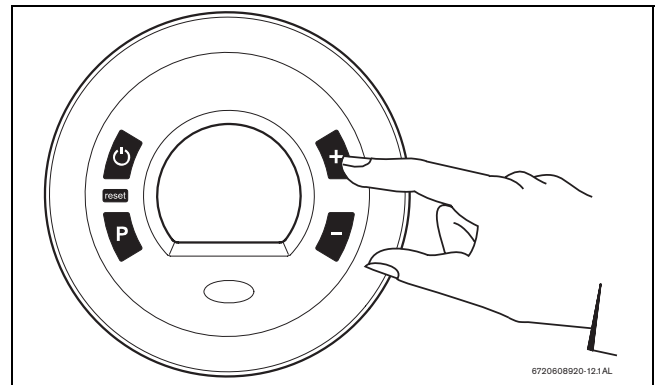

Fig. 17

- ▶ Once the desired temperature is set, open the hot water tap.



This appliance has an electronically controlled gas valve that modulates the burner input in response to both varying hot water flow rates and/or changes in any incoming and outgoing water temperatures.

5.5 OPERATION

Turn ON the main switch and the appliance is ready to work.

- ▶ When a hot water tap is opened, main burner ignites and LCD displays indication .

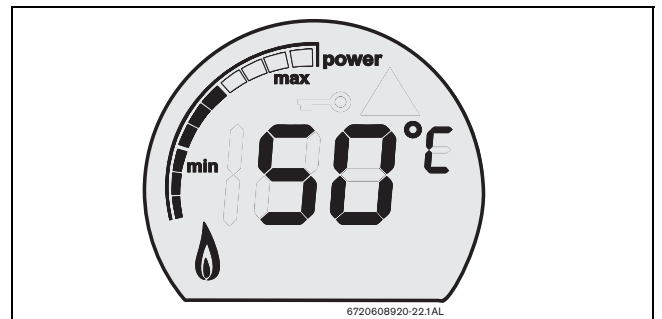

Fig. 18



LCD flashes until selected temperature is reached.

5.6 DRAINING DOWN THE APPLIANCE

If there is a risk of freezing, proceed as follows:

- ▶ Close the cold water valve of the water heater(s).
- ▶ Open hot water taps to drain the water heater(s).
- ▶ Remove all the water contained inside of the appliance.



CAUTION:
To avoid damage to the appliance care should be taken not to install the water heater where there is a risk of freezing conditions.



The internal frost protection is designed to provide protection for the water heater down to approximately -10 °C for short term conditions only. It will not protect the appliance in areas where the temperature is frequently expected to be below freezing.

- The frost protection will not protect the installation outside the appliance from freezing. Suitable measures should be taken to protect the installation against frost damage.

5.7 RESET BUTTON



This appliance has an error code system. These codes are shown on the LCD display. (Fig. 8, pos. 4).

If the LCD shows the error symbol  do not shut off power or unplug the water heater. Follow instructions below to reset the error first. Record the error code on LCD and consult chapter 11 to identify the error.

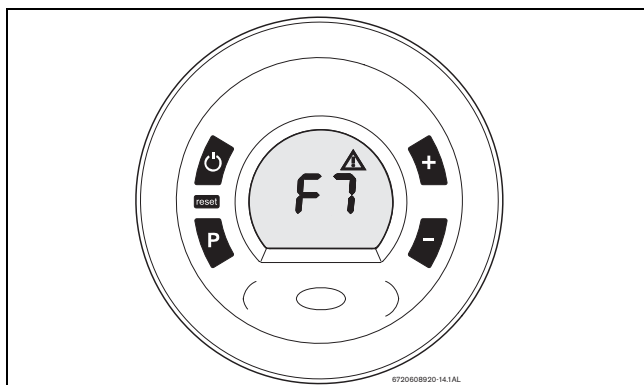

Fig. 19 Error code

After following instructions indicated in “Troubleshooting”. → chapter 11.

- ▶ Press reset button firmly in order to return the water heater to normal operation.

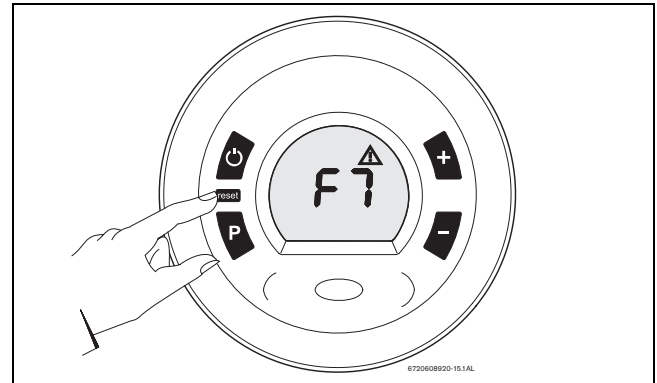

Fig. 20 Reset button

If the fault remains and cannot be cleared by pressing the reset button, contact Worcester, Bosch Group for assistance.

5.8 LOCKED CONDITION

This condition is only valid for appliances with one or more remote controls installed.

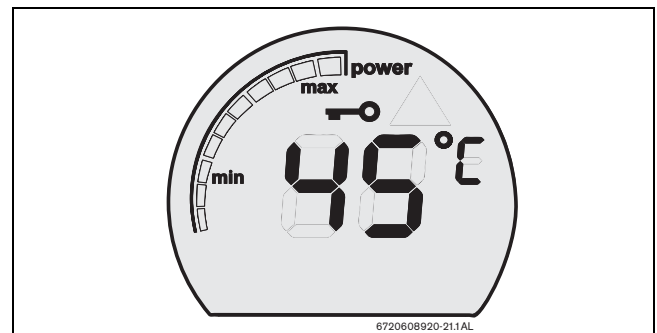



Fig. 21 Locked condition

Whenever LCD shows  the temperature setting cannot be adjusted. In this case, the appliance is being operated by the remote control which has already set an output temperature. Appliance will be unlocked automatically, 5 minutes after closing hot water tap.

6 INSTALLATION INSTRUCTIONS



DANGER:

- ▶ ISOLATE THE MAINS GAS SUPPLY BEFORE STARTING ANY WORK AND OBSERVE ALL RELEVANT SAFETY PRECAUTIONS.



CAUTION:

- ▶ Do not install the appliance where the inlet water temperature exceeds 60°C. In such cases we recommended the installation of a thermostatic mixing valve on the water supply to the appliance.

6.1 GAS SUPPLY

Appliances using Natural Gas (NG) must be connected to a governed meter.

- ▶ Liquid Petroleum Gas (LPG) must be connected to a regulator.
- ▶ Installation and connection of the gas supply to the water heater must be in accordance with the relevant gas regulations (page 5).
- ▶ Under no circumstance should be size of the gas supply pipe be less than 22 mm.
- ▶ The meter or regulator and pipe work to the meter must be checked, preferably by the gas supplier. This is to ensure that the equipment is in good working order and can meet the gas flow and pressure requirements, in addition to the demand from any other appliance being served.
- ▶ Ensure that the flow and pressures for the regulator installed are those indicated for the consumption of the appliance (see technical data in table 4).

6.2 APPLIANCE LOCATION AND CLEARANCES

CONSIDERATIONS RELEVANT TO LOCATION

- ▶ This appliance must be installed at a suitable location onto a fixed, rigid vertical surface at least the same size as the appliance and capable of supporting the appliance weight.
- ▶ The heater must not installed above a source of heat.
- ▶ Observe the minimum installation measurements indicated in Fig. 22.
- ▶ The appliance must not be installed in sites where the ambient temperature is expected to drop below 0°C. Where there is a risk of freezing, disconnect and drain the appliance (→ chapter 5.6).
- ▶ Ensure that a fused spur exists at the place were the appliance will be installed.
- ▶ Ensure that condensate can be drained.

VENTILATION

- ▶ Ventilation needs to comply with the current standards.
- ▶ Do not store or use any combustible materials (paper, thinners, paints, propellant, cleaning agents etc.) inside or within the vicinity of the appliance.

Where these requirements are impossible to fulfill, an alternative site must be selected.

SURFACE TEMPERATURE



NOTICE:

- ▶ No surface protection is required against heat transfer from the appliance.

6.3 MINIMUM CLEARANCES

Choose the installation site with the following limitations in mind:

- ▶ Ensure adequate access for maintenance work, observing the minimum distances indicated in Fig. 22.

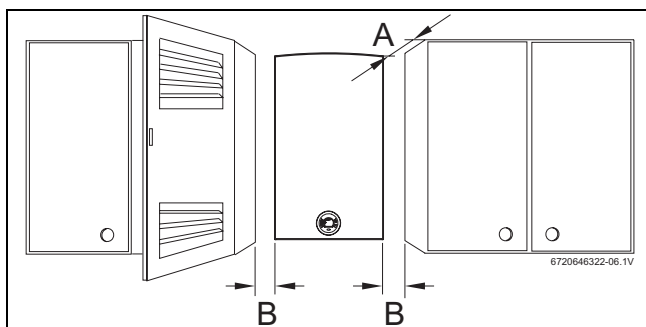



Fig. 22 Minimum distances

- A Front > 20 mm (to a removable surface)
- B Side > 10 mm

6.4 INSTALLATION OF FIXING BRACKET



WARNING: Damage caused by drilling!

- ▶ Before drilling ensure that there are no pipes, electrical cables, damp proof courses or other hazards.



Before installing the fixing bracket, ensure that it is possible to install the water/gas/flue connections in line with building regulations and the guidance given in this manual.

- ▶ Position the fixing bracket at the point of installation.
- ▶ Mark the position of the holes for the fixing bracket, make sure that the fixing bracket is level, only then drill the holes.

- ▶ Fix the fixing bracket to the wall using the screws and plugs provided.

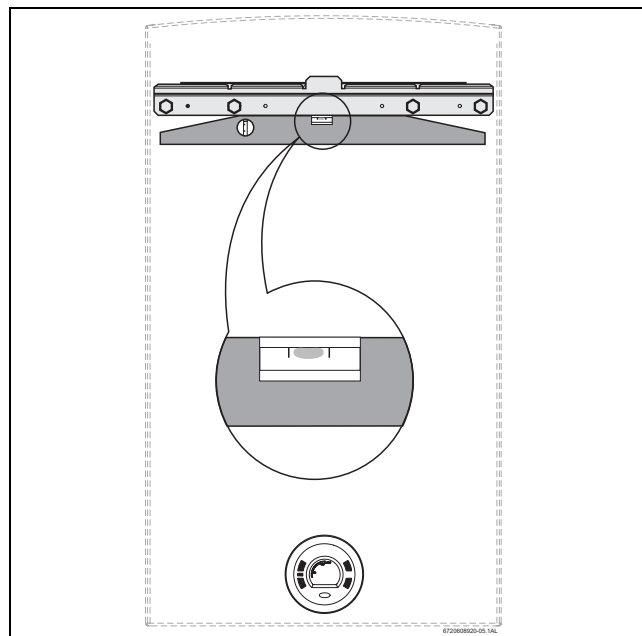



Fig. 23 Install the fixing bracket

6.5 INSTALLATION



NOTICE: Debris from the system can damage the appliance and reduce efficiency!

- ▶ Failure to comply with the guidelines for water quality will invalidate the warranty.

BEFORE CLEANING THE SYSTEM:

Ensure that the system and pipe work is in good working order.

Water quality can have an impact on appliance longevity and may void the manufacturer's warranty. For water analysis data call your local water supplier, or if on a well, have well water analyzed periodically. If water quality exceeds one or more of the values specified below, Bosch recommends installing a water conditioner or softener. If the water heater is operating in applications where the outlet temperature exceeds 60°C, a water softening system is strongly recommended. The higher the set temperature is on the appliance, the greater the risk for scale/mineral deposits. Damage from scale/mineral deposits is not covered under warranty. Refer to manufacturer's limited warranty.

Description	Max. Levels	
pH	pH	6.5 - 8.5
TDS (total Dissolved Solids)	mg/l or ppm	500
Total hardness	mg/l or ppm	100
Aluminum	mg/l or ppm	2.0
Chlorides	mg/l or ppm	250
Copper	mg/l or ppm	1.0
Iron	mg/l or ppm	0.3
Manganese	mg/l or ppm	0.05
Zinc	mg/l or ppm	5.0

Tab. 5

- ▶ Remove appliance from the packaging.
- ▶ Ensure that all indicated parts are included.
- ▶ Remove the plastic caps from the gas and water connections.
- ▶ Loosen the two Philips head screws located on the bottom rear of cover (→ Fig. 24).

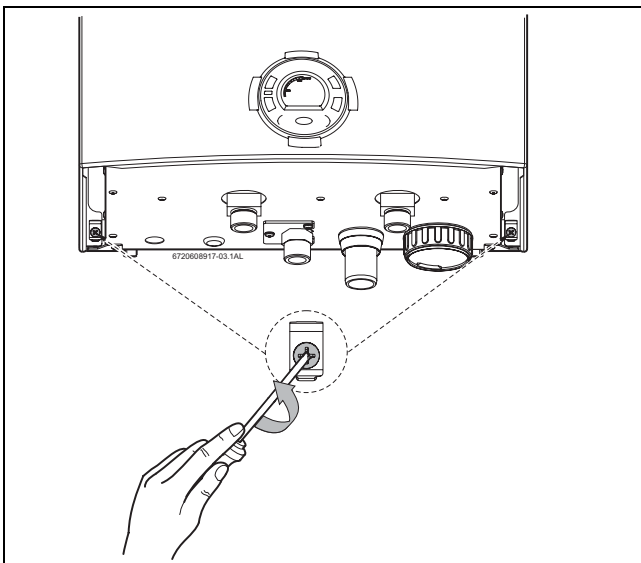

Fig. 24 Loosen the two screws

- ▶ Lift front cover panel upward and remove.

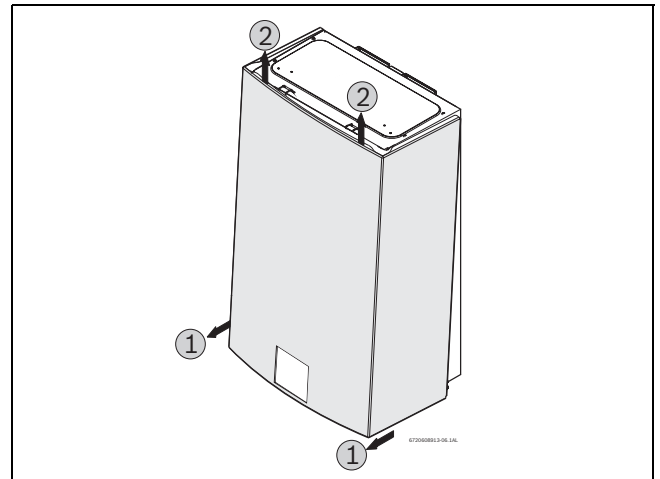

Fig. 25

- ▶ Hang the appliance in a vertical position from the fixing bracket, taking care to correctly locate the appliance on the central lug of the bracket.

CAUTION:

▶ Never rest the heater on the gas or water connections.

i For ease of installation it is recommended that the water connections are installed first, followed by the remaining of the connections.

6.6 WATER CONNECTION

CAUTION:

- ▶ Isolate the mains supplies before starting any work and observe all relevant safety precautions.

- ▶ Mark the hot and cold water pipes in order to avoid confusion.
- ▶ Join the hot and cold pipework onto the connections provided.

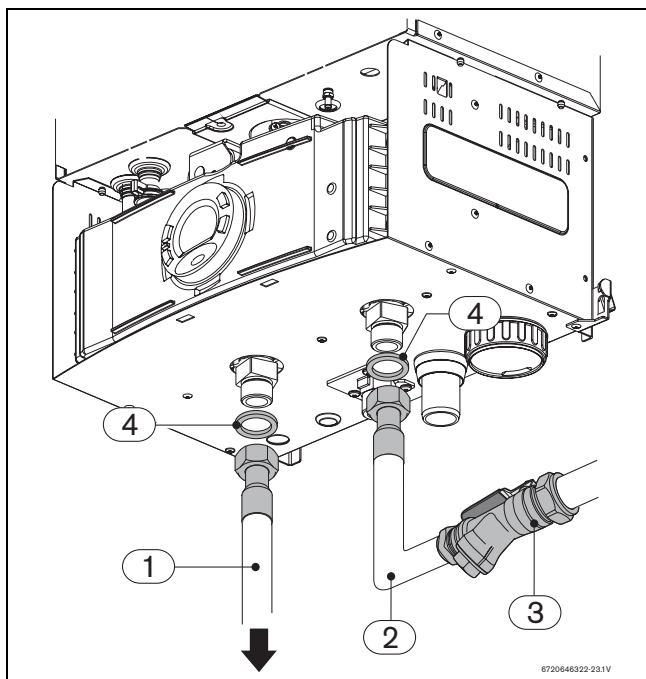

Fig. 26

- 1 Hot water outlet pipe
- 2 Cold water inlet pipe
- 3 Water valve with filter
- 4 Water sealing washer

- ▶ Make the cold (inlet) water connection using the sealing washer, short 22mm diameter (with attached nut) connection pipe and water isolation valve supplied with the appliance.
- ▶ Make the hot (outlet) water connection using the sealing washer and short 22mm diameter pipe (with attached nut) supplied with the appliance.
- ▶ In order to prevent problems caused by water hammer, it is advisable to install a non-return valve.

i Make sure that connections doesn't obstruct access to the condensate trap cover (→ Fig. 27, pos. 1).

6.7 CONDENSATE PIPE WORK

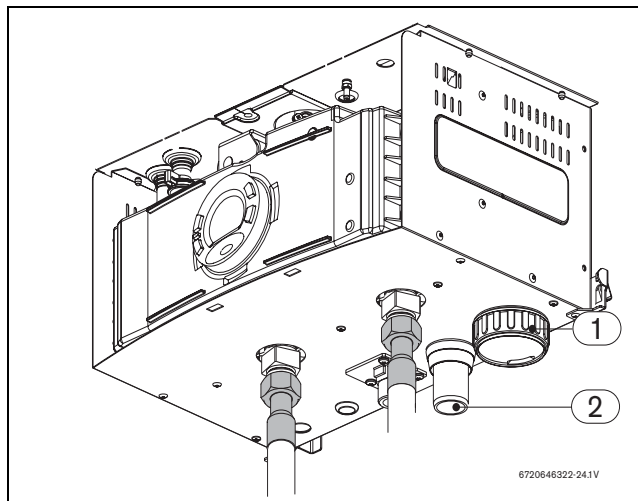

Fig. 27

- 1 Condensate trap cover
- 2 Condensate drain connection

NOTICE:

- ▶ Where a new or replacement water heater is being installed, access to an internal "gravity discharge" point should be one of the factors considered in determining water heater location.
- ▶ The condensate pipe must be nominally 32mm Ø plastic pipe.
- ▶ The condensate pipe work must fall at least 50mm per metre towards the outlet and should take the shortest practicable route.
- ▶ Ensure there are no blockages in the pipe run.

Key to condensate illustrations

1	Condensate discharge from water heater
2	Soil and vent stack
3	Minimum 450mm and up to three storeys
4	Visible air break at plug hole
5	Sink or basin with integrated overflow
6	75mm sink waste trap
7	Condensate pump
8	Condensate trap

Tab. 6

6.7.1 INTERNAL CONNECTIONS

In order to minimise risk of freezing during prolonged cold spells, the following methods of installing condensate drainage pipe should be adopted, in order of priority.

Wherever possible, the condensate drainage pipe should be routed and terminated so that the condensate drains away from the water heater under gravity to a suitable

internal foul water discharge point such as an internal soil and vent stack. A suitable permanent connection to the foul waste pipe should be used.

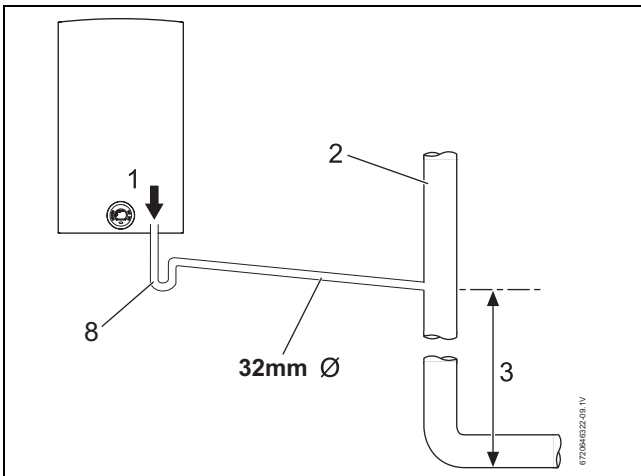

Fig. 28 Disposal to soil vent stack

Alternatively if the first option is not possible an internal kitchen or bathroom waste pipe, washing machine waste pipe etc. can be used. Ensure that the condensate drain pipe is connected “down stream” of the waste trap.

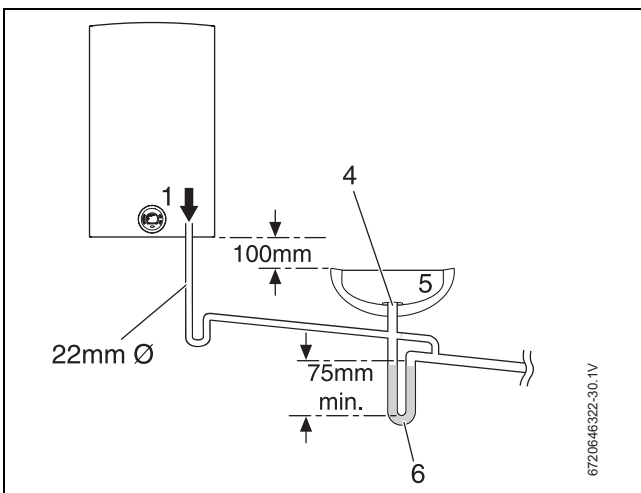

Fig. 29 Disposal to a waste pipe

CONDENSATE PUMP

Where “gravity discharge” to an internal termination is not physically possible, or where very long internal runs would be required to reach a suitable discharge point, condensate should be removed using a proprietary condensate pump, of a specification recommended by the water heater or condensate pump manufacturer.

The pump outlet pipe should discharge to a suitable internal foul water discharge point such as an internal soil and vent stack, internal kitchen or bathroom waste pipe, washing machine waste pipe etc. A suitable permanent connection to the foul waste pipe should be used.

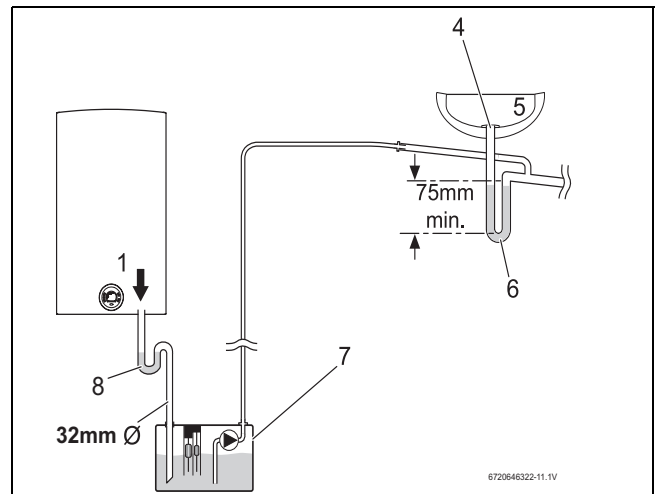

Fig. 30 Condensate pump disposal

6.7.2 EXTERNAL CONNECTIONS

- NOTICE:** Freezing conditions
 - ▶ Pipe work length should be kept to a minimum and the route as vertical as possible.
 - ▶ Weather proof insulation must be used.
- NOTICE:** Condensate waste
 - ▶ Care should be taken when siting a soak-away to avoid obstructing existing services.

Continued - Key to condensate illustrations	
8	Condensate trap
9	100mm Ø minimum plastic pipe
10	Drainage holes
11	Limestone chippings
12	Bottom of sealed tube
13	Insulate and increase pipe size
14	Pipe work transition
15	External air break
16	Air gap
17	External rain water pipe into foul water
18	43mm 90° male/female bend
19	PVCu strap on fitting
*	Condensate trap of 75mm already incorporated into the water heater

Tab. 7

If no other discharge method is possible then the use of an externally run condensate drainage pipe terminating at a suitable foul water discharge point, or purpose-designed soak away, may be considered. If this method is chosen then the following measures should be adopted:

INSTALLATION INSTRUCTIONS

- ▶ The external run be kept as short as possible and not exceed three metres.
- ▶ The pipe should be run internally as far as possible before going externally and the pipe diameter should be at least 32mm before it passes through the wall to the exterior. The pipe should be insulated using suitable waterproof and weather resistant insulation.
- ▶ The external pipe should take the shortest and least exposed route to the discharge point, and should "fall" as steeply as possible away from the water heater, with no horizontal runs in which condensate might stand.
- ▶ The use of fittings, elbows etc. should be kept to a minimum and any internal "burrs" on cut pipe work should be removed so that the internal pipe section is as smooth as possible.

FITTING AN EXTERNAL AIR BREAK

- Refer to figure 31 when a rain water down pipe is used to dispose of condensate.
- An air break must be installed in the 43mm pipe work, between the water heater condensate outlet and the drainpipe, outside the property, to avoid flooding during adverse weather conditions.

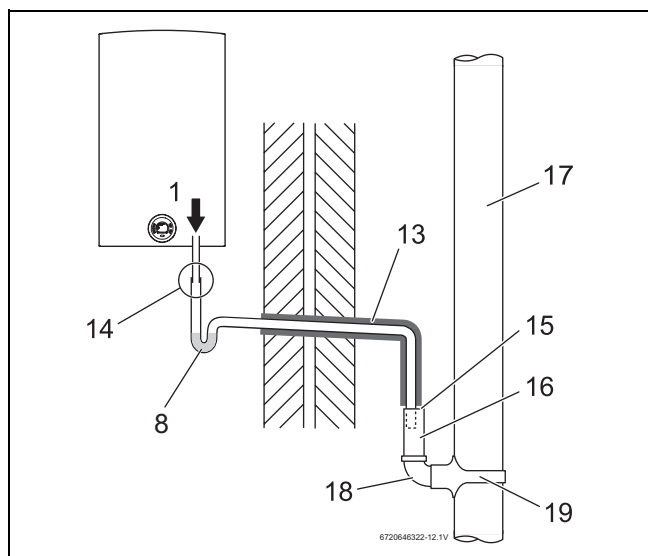

Fig. 31 Disposal into a rainwater down pipe

i Condensate drainage pipe can be run above or below ground.

Where the pipe terminates over an open drain or gully, the pipe should terminate below the grating level, but above water level, in order to minimise "wind chill" at the open end.

The use of a drain cover (such as those used to prevent blockage by leaves) may offer further protection from wind chill.

Pipe drainage will be improved if the end is cut at 45° as opposed to a straight cut.

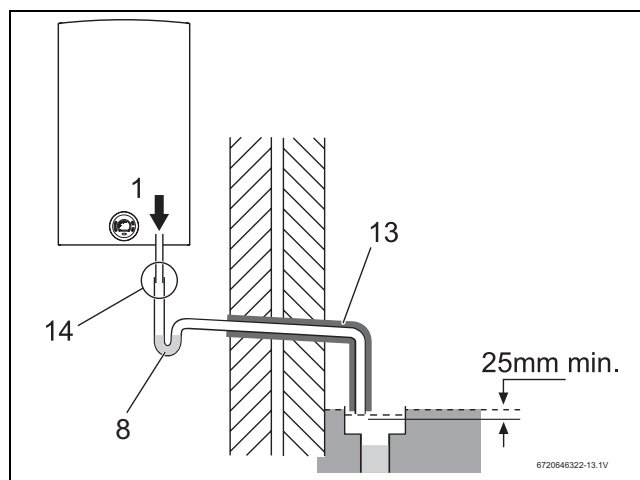

Fig. 32 External disposal

CONDENSATE SOAK AWAY

- The condensate drainage pipe may be run above or below the ground to the soak away. The examples shown on this page run above ground.
- The soak away must use a 100mm Ø plastic tube with two rows of three 12mm holes on 25mm centres and 50mm from the bottom of the tube. The holes must face away from the house.
- The tube must be surrounded by at least 100mm of limestone chippings to a depth of 400mm.

i Minimum hole size for the condensate soak away must be 400mm deep by 300mmØ.

In situations where there are likely to be extremes of temperature or exposure, the use of a proprietary trace-heating system for external pipe work, incorporating an external frost thermostat, should be considered. However, all other guidance above and the instructions for the trace heating system, should be closely followed.

NOTICE: Unheated internal areas.
▶ Internal pipe runs in unheated areas such as lofts, basements and garages should be treated as external runs.

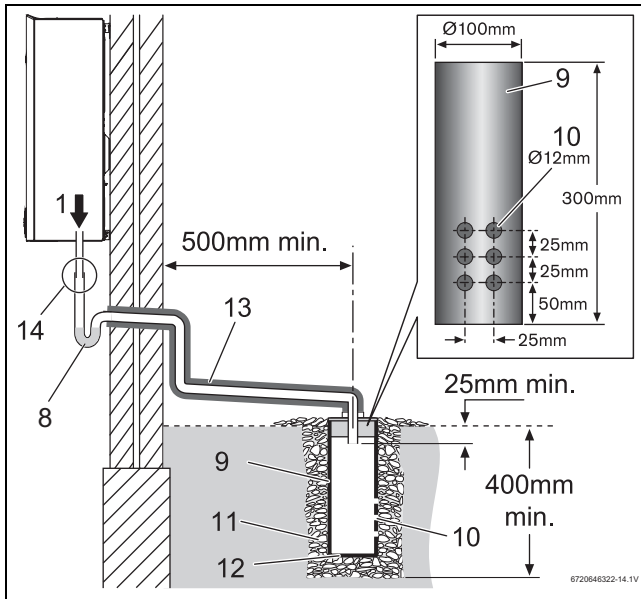

Fig. 33 Soak away

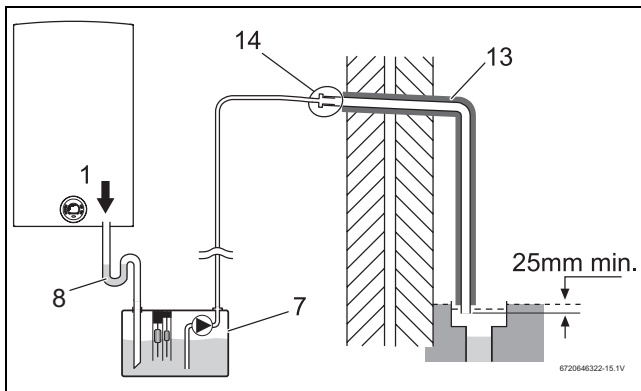

Fig. 34 Condensate pump to external disposal

6.8 GAS CONNECTION



DANGER:

- ▶ TURN OFF THE GAS SUPPLY AND ISOLATE THE MAINS SUPPLIES BEFORE STARTING ANY WORK AND OBSERVE ALL RELEVANT SAFETY PRECAUTIONS.



Only use accessories recommended in this manual.

The gas connection must comply with current building requirements.

- Ensure that the inlet pipe is clean.
- Use a pipe support and an appropriate clamp to make the gas inlet connections to the appliance.
- Install a gas shut-off tap as near to the appliance as possible.
 - The gas isolating valve provided must be used to connect the water heater to the gas main.
 - Tighten the threaded head on the gas inlet (→ Fig. 35, pos. 1) and make connection to the gas supply pipe (→ Fig. 35, pos. 2).

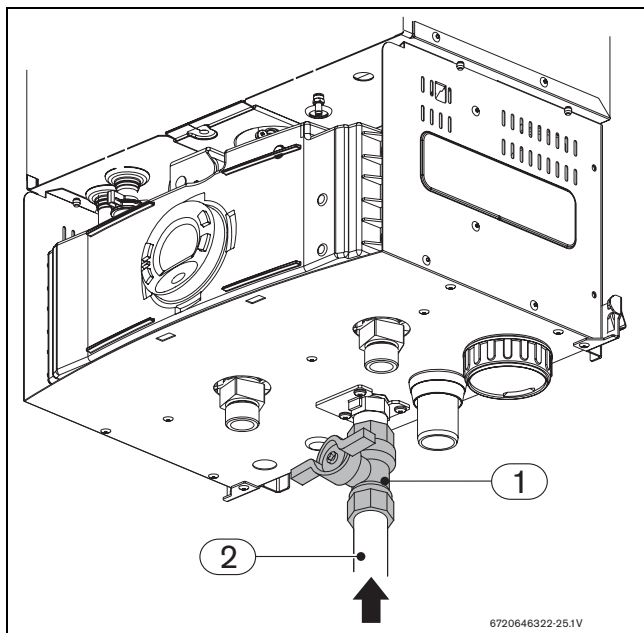

Fig. 35

- 1 Gas isolation valve (supplied with appliance)
- 2 Gas supply pipe

6.9 FLUE OPTIONS

6.9.1 FLUE TERMINAL POSITIONS

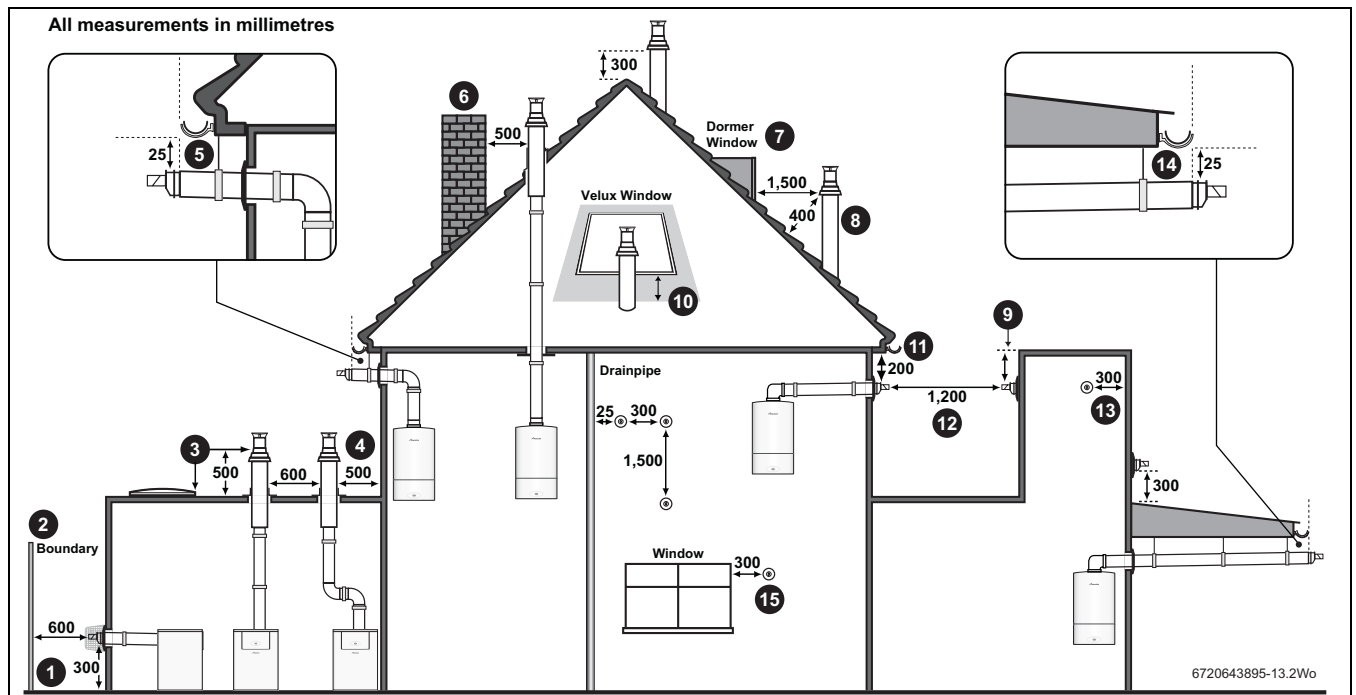

Fig. 36 Flue terminal positions



NOTICE:

- ▶ All measurements are the minimum clearances required.
- ▶ Terminals must be positioned so to avoid combustion products entering the building.
- ▶ Support the flue at approximately one metre intervals and at a change of direction, use suitable brackets and fittings (Flue bracket 125mm part number :7 716 191 174).

Key to illustration

1. Flue clearance must be at least 300mm from the ground. Terminal guards must be fitted if the flue is less than 2 metres from the ground or if a person could come into contact with the flue terminal.
2. 600mm distance to a boundary, unless it will cause a nuisance. BS 5440: Part 1 recommends that care is taken when siting terminals in relation to boundaries.
3. 600mm minimum clearance from a skylight to a vertical flue.
4. Vertical flue clearance, 500mm to non-combustible building material, and 1,500mm clearance to combustible building material.
5. The dimension below eaves, gutters, pipes and drains can be reduced to 25mm, as long as the flue terminal is extended to clear any overhang. Any external flue joints must be sealed with a suitable silicon sealant.
6. 500mm clearance to any vertical structure on a roof, 600mm to room sealed flue or 1,500mm to an open flue.
7. 1,500mm between a vertical flue terminal and a window or dormer window.
8. 400mm from a pitched roof or in regions with heavy snow fall 500mm.
9. The flue cannot be lower than 1,000mm from the top of a light well due to the build up of combustion products.
10. 2,000mm below a Velux window, 600mm above or to either side of the Velux window.
11. 200mm below eaves and 75 mm below gutters, pipes and drains.
12. 1,200mm between terminals facing each other.
13. 300mm to an internal or external corner.
14. The dimension below eaves, balconies and car ports can be reduced to 25 mm, as long as the flue terminal is extended to clear any overhang. Any external flue joints must be sealed with suitable silicon sealant.
15. 300mm above, below and either side of an opening door, air vent or opening window.



Installations in car ports are not recommended.



CAUTION:

- ▶ Where a flue system is not going to be accessible, provision must be made for service and inspection.
- ▶ Voids containing concealed flues must have at least one inspection hatch no less than 300mm square.
- ▶ Flue joints within the void must not be more than 1.5M from the edge of the inspection hatch.
- ▶ Inspection hatches should be located at changes of direction.
- ▶ If this is not possible, bends should be viewable from both directions.

6.9.2 CALCULATION OF THE MAXIMUM FLUE PIPE LENGTH Ø80/125 MM

How to calculate the total length of the concentric flue pipes:

- ▶ Determine the total length of the concentric flue pipes and enter in table 8, line 1.
- ▶ Count the number of 90° elbows used, multiply by 2m, and enter that value in table 8, line 2.
- ▶ Count the number of 45° elbows used, multiply by 1.5m, and enter that value in table 8, line 3.



Do not count terminals and first elbow.

Concentric flues			
1	Straight section length	__ x 1 =	_____
2	90° elbows (qty)	__ x 2 =	_____
3	45° elbows (qty)	__ x 1.5 =	_____
4	Total equivalent flue length=		_____

Tab. 8

EXAMPLE

Concentric conduct:

- 4 units of 1m straight sections
- 1 unit of 1m straight section
 - Total length = 5 meters
- 2 - 90° elbows

EXAMPLE TABLE:

Concentric conduits			
1	Straight section length	5 x 1 =	5
2	90° elbow (qty)	_1_ x 2 =	2
3	45° elbow (qty)	_0_ x 1.5 =	0
4	Sub-total:		7

Tab. 9

Note: Do not count terminal and first elbow.



Total maximum length for concentric flue pipes must not exceed 8 meters.

6.9.3 CONCENTRIC FLUE KITS - Ø80/125 MM

To install the concentric accessory, proceed as follow;

- ▶ Put the blue gasket provided with the appliance between the appliance and the accessory.
- ▶ Tighten the 3 screws supplied with the flue kit.

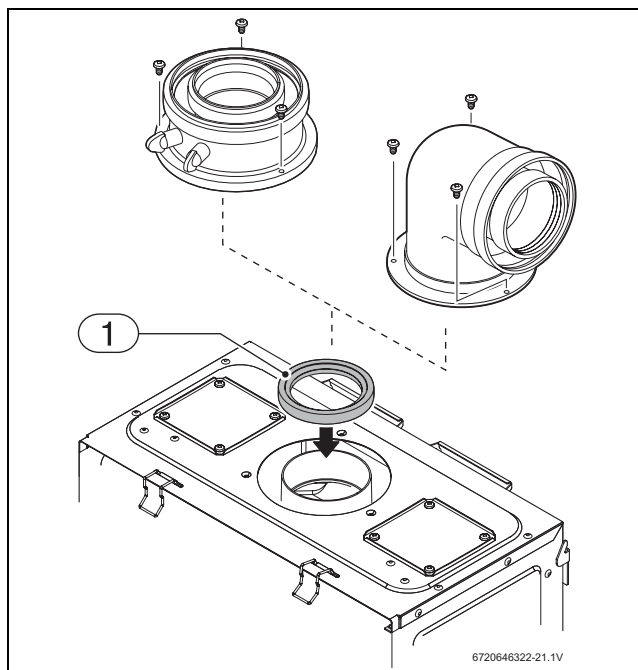

Fig. 37 Concentric accessory + gasket

- 1 Flue gasket (supplied with the appliance)

6.10 FLUE INSTALLATION

HORIZONTAL FLUE (80/125mm diameter)

For 80/125 mm vertical flues and 80/125mm horizontal flues, please refer to separate instructions supplied with the flue kit.



To ease assembly of flue components, apply silicone lubricant to sealing surfaces.

6.10.1 MEASURING THE FLUE (STANDARD FLUE):

- ▶ Measure from the outside of the wall to the centre line of the flue turret to determine length L.
- ▶ Subtract 50mm from the length L to give the correct dimension to the flue elbow connection.
- ▶ If the length L falls within the telescopic range of 350 to 570mm or 570 to 790mm using the longer telescopic flue, then no cutting will be required.
- ▶ If the required length is less than 350mm the standard telescopic flue can be modified, refer to fig. 39.
- ▶ If the required length is greater than 570mm, then the longer telescopic flue, giving a range of 570 - 790mm, can be used.
- ▶ If the required length is greater than 790mm, then flue extensions will have to be used. Refer to the 80/125 Horizontal Flue Instruction manual provided in the telescopic flue kit.
- ▶ Refer to section 7.1 for flue options.

Adjusting the telescopic flue length:

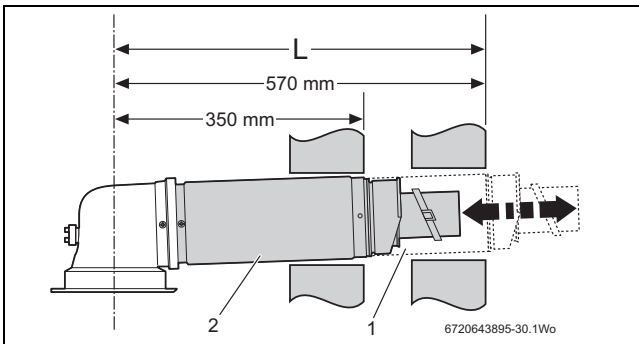

Fig. 38 Standard telescopic flue

Extend tube (1) by withdrawing from tube (2) to achieve the flue length required, between 350 - 570mm.

Secure with screw provided and seal joint with the aluminium tape supplied.

6.10.2 REDUCING THE TELESCOPIC FLUE LENGTH:



Ensure that the "TOP" label is facing up before securing the flue section to the turret.

The flue terminal MUST be fitted with the 'TOP' label uppermost to allow the correct fit and use of the plume management system.

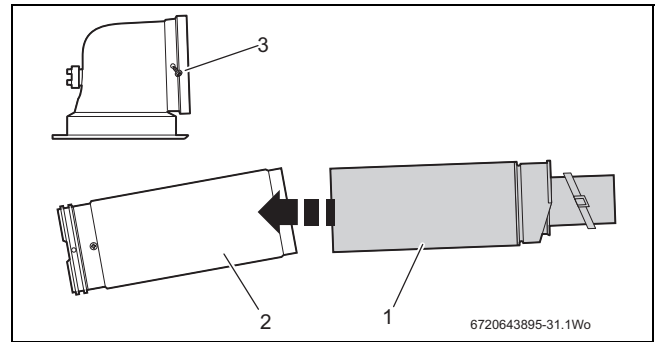

Fig. 39 Reducing the standard terminal

- ▶ Remove securing screws (3) to detach the terminal assembly from the turret.
- ▶ Slide terminal section (2) from the terminal assembly and discard.
- ▶ To use terminal (1) without cutting remove the location lug (4) on the inner flue tube (5) and remove any burrs.

To reduce the flue length further:

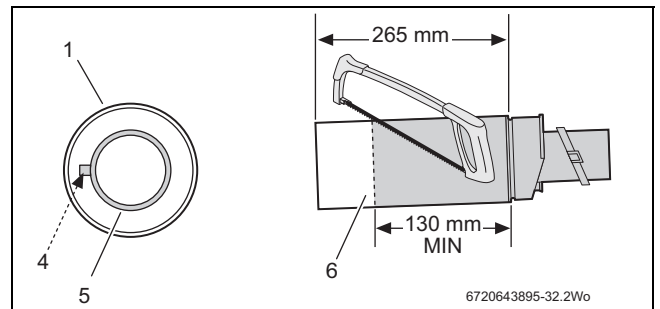

Fig. 40 Further reduction

- ▶ Mark the length required for the terminal as shown (min. 130mm) and cut square, taking care not to damage the tubes.
- ▶ Remove any burrs and chamfer the outer edge of the tubes to assist ease of connection and prevent seal damage.



The aluminium tape is not required when reducing the terminal.

6.10.3 INSTALLING THE TELESCOPIC FLUE:

Refer to figure 41.

1. Set the flue length to the distance required, secure with screws provided.
2. Seal the joint with the aluminium tape provided.
3. Slide the inner wall seal onto the terminal.
4. If fitting from inside the building; slide the outer wall seal onto the terminal.

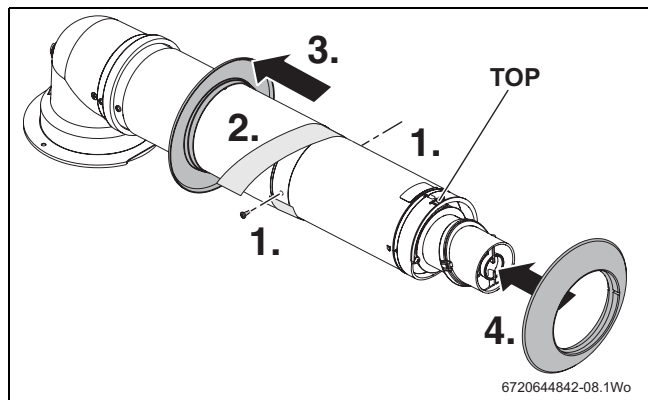

Fig. 41 Telescopic flue

i The turret securing screws are from the water heater and are not in flue kit.

ADDITIONAL NOTES AND REMINDERS:

- Ensure that all cut lengths are square and free from burrs.
- The flue is sealed when assembled correctly and the components are pushed fully home.
- The flue is set at an angle of 3° or 52mm per metre length.
- Support the flue at approximately one metre intervals and at a change of direction, use suitable brackets and fittings.
Flue bracket 125mm part number :7 716 191 174)

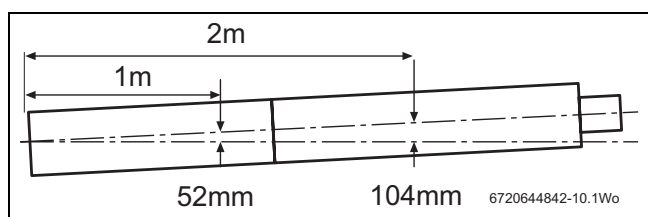



Fig. 42 Slope for condensate disposal

6.10.4 FLUE TERMINAL PLUME RE-DIRECTION

The flue discharge can be re-directed allowing some plume redirection control, alternatively, a complete plume management system can be fitted to the flue terminal.

RE-DIRECTING THE FLUE DISCHARGE

1. Using a suitable tool, unclip (1 & 2) the terminal end and rotate through 180°.

NOTICE:
 DO NOT rotate the complete terminal assembly.

1. Refit to the terminal, ensuring that the clips (1 & 2) in Fig. 43 are engaged and secure.
2. Loosen screws (3) and rotate the entire outlet assembly to redirect the plume. Tighten screws (3) to secure in the required position.

i The flue terminal outlet has built-in stops to limit rotation for horizontal flue to allow condensate to run back into the water heater for safe disposal. Do not attempt to force beyond the limit stops.

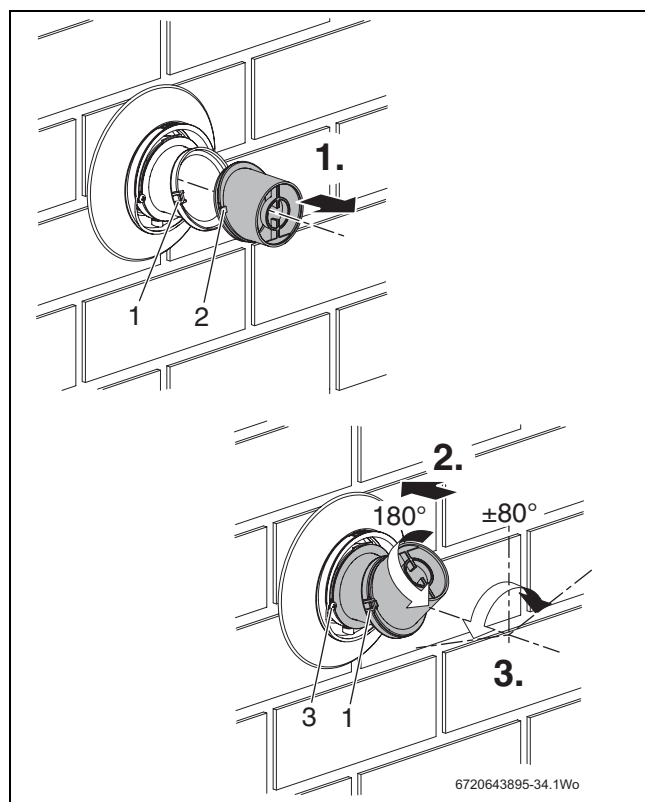

Fig. 43 Plume redirection



NOTICE: Outlet position

► The flue terminal outlet position must follow those stated in the relevant appliance instruction manual. When redirecting the flue discharge the outlet terminal must be at least 1500mm from any opening in the direction of the discharge to prevent combustion products from entering the building.

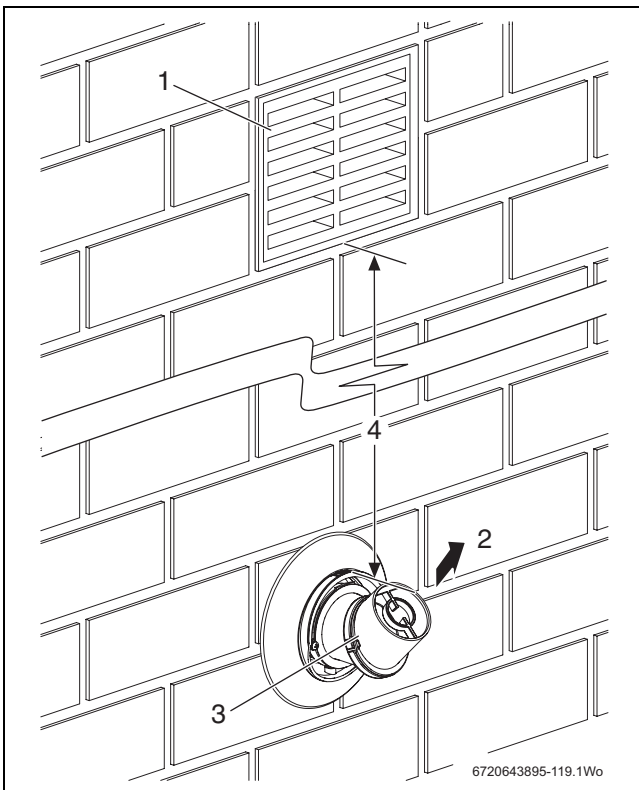

Fig. 44 Plume distance to opening

1	Opening in building
2	Flue discharge
3	Plume deflector
4	Minimum 1500mm from an opening in the building

Tab. 10 Key to figure 44

6.11 FILLING THE CONDENSATE TRAP

CAUTION:

Before the first start up of the appliance, after a long period of inactivity or whenever it follows the cleaning of the condensate trap;

- ▶ Fill the condensate trap with water, to prevent flue gases entering the room where the appliance is installed in.

i The condensate trap can be filled before or after connecting the flue gas pipe.

6.11.1 FILLING THE CONDENSATE TRAP BEFORE FLUE GAS PIPE INSTALLATION

- ▶ Fill the condensate trap by pouring approximately 400ml of water into the flue gas connector on the top of the appliance (→ Fig. 45).

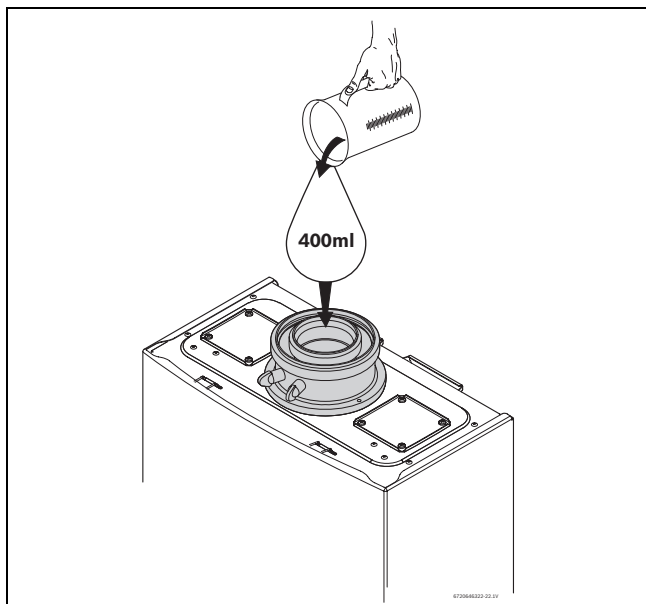

Fig. 45 Filling the condensate trap at start up

6.11.2 FILLING THE CONDENSATE TRAP AFTER FLUE GAS PIPE INSTALLATION

Please proceed as follows;

- ▶ Remove front cover (→ Fig. 25).
- ▶ Open the four clips and remove the combustion cover.

- ▶ Remove the clip and disconnect the drain pipe (→ Fig. 46).

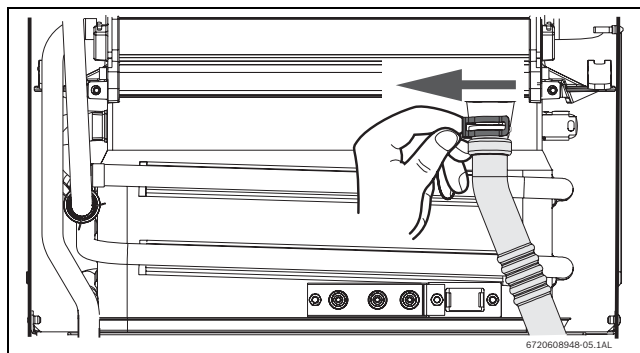

Fig. 46

- ▶ Fill the condensate trap by pouring approximately 400ml of water into the top of the drain pipe. To avoid damage to the appliance use a funnel (→ Fig. 47).

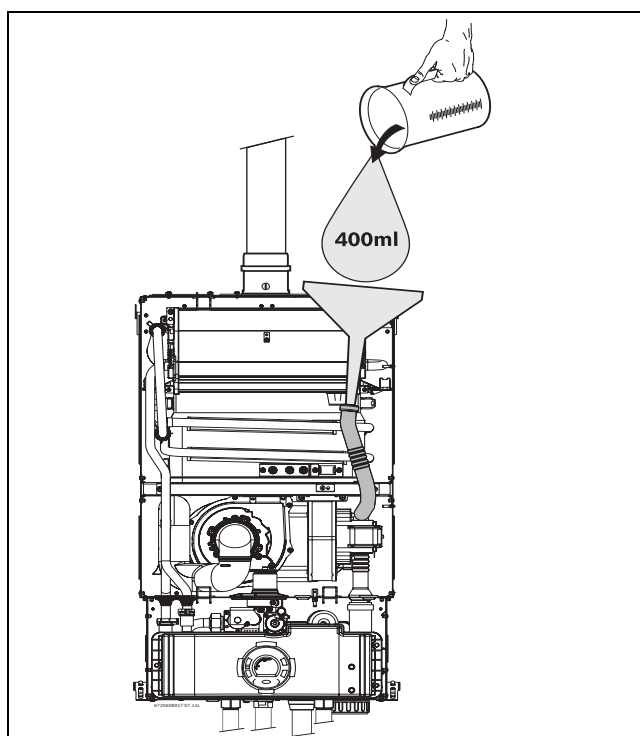



Fig. 47 Filling the condensate trap after installation

i After appliance has been out of use for a long time or after cleaning the siphon, refill the condensate trap with water.

7 FLUE OPTIONS

7.1 FLUE ACCESSORIES (DIAMETER IN MM)

 **DANGER:** Make sure that all flue connections are properly sealed.

- ▶ Failure to follow this requirement may cause dangerous exhaust gases to enter living space which may result causing personal injury or loss of life.

7.1.1 CONCENTRIC PIPE ADMISSION / EXHAUSTION Ø80/125 MM

Description	Part number
Standard telescopic flue & terminal (405 - 600mm)	7-719-003-702
Vertical 1,365mm BF kit (inc. adaptor)	7-719-002-431
Extension flue kit (960mm)	7-719-003-666
90° flue bend	7-719-003-664
45° flue bend	7-719-003-665
High level horizontal flue adaptor	7-719-002-433
Support bracket kit	7-716-191-174
Flashing - flat roof	7-716-191-090
Flashing - pitched roof	7-716-191-091

Tab. 11 Flue accessories Ø 80/125mm

 **NOTICE:** Support the flue at approximately one metre intervals and at a change of direction, use suitable brackets and fittings.

 **CAUTION:** Non accessible flue systems:

- ▶ Where a flue system is not going to be accessible, provision must be made for service and inspection.
- ▶ Voids containing concealed flues must have at least one inspection hatch no less than 300mm square.
- ▶ Flue joints within the void must not be more than 1.5M from the edge of the inspection hatch.
- ▶ Inspection hatches should be located at changes of direction.
- ▶ If this is not possible, bends should be viewable from both directions.

8 ELECTRICAL CONNECTION



DANGER: RISK OF ELECTRIC SHOCK!

- ▶ ISOLATE THE MAINS ELECTRIC SUPPLY BEFORE STARTING ANY WORK AND OBSERVE ALL RELEVANT SAFETY PRECAUTIONS.

All regulation, verification and safety mechanisms have been rigorously tested in the factory and are ready for use.

8.1 ELECTRICAL SUPPLY

- Supply: 230V - 50 Hz, 140 Watts.
- Cable: PVC insulated 0.75 mm² (24 x 0.2 mm) temperature rated to 90 °C.
- External 3A fuse to BS1362.
- The appliance must be earthed.
- This appliance must not be connected to a three phase supply.
- IP20.
- Wiring must comply with the latest IEE wiring regulations.

8.2 EQUIPOTENTIAL BONDING

8.2.1 MAIN EQUIPOTENTIAL BONDING

Main equipotential bonding is carried at the origin of the electrical installation and connected to the main electrical earthing terminal. Metal pipes can be used as bonding conductors if joints are metal to metal and electrically continuous. The IEE Wiring Regulations (BS 7671:2008) require that extraneous conductive parts must be connected to the main electrical earth. The main bonding of incoming metallic services must be as close as practical to their entry point, before any branch pipe work and a maximum of 600mm from an internal meter. Bonding conductors must be copper and the same size as other bonding conductors and not less than 10mm². The bonding conductors must be permanently fixed to the metal pipes with clamps and labels (to BS 951) in a visible position to allow for inspection.

8.2.2 SUPPLEMENTARY BONDING

Supplementary bonding is normally carried out in an area of increased shock risk e.g. bathrooms. Consult a qualified electrician for them to determine if the installation requires supplementary bonding as specified in the 17th edition of the IEE Wiring regulations (BS 7671:2008).

8.3 CONNECTION



The mains supply to the appliance must be either:

- ▶ The mains electrical supply to the water heater and system wiring centre must be common and through either a common fused double pole isolator or a fused three pin plug and unswitched socket.
- ▶ The isolator shall be situated next to the water heater for new systems and, where practicable, replacement heaters.
- ▶ The isolator must have a contact separation of 3mm minimum between all poles. Any system connected to the heater must not have a separate electrical supply.

- ▶ Connect the mains electrical cable to an earthed power point.

8.4 POWER CABLE

The appliance is provided with a labeled power cord and earthed main plug.



If the power cable gets damaged it must be replaced with a genuine spare part.

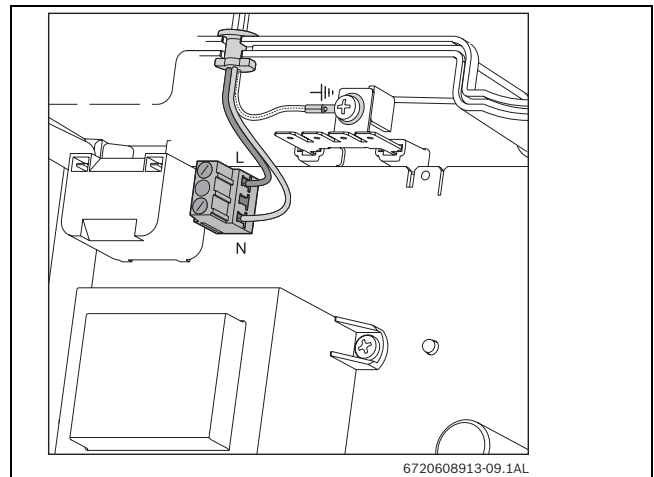

Fig. 48 Mains power cable connections

8.5 POSITION OF THE FUSES IN CONTROL UNIT

To check fuses, proceed as follows;

- ▶ Remove the front cover (→ Fig. 24).
- ▶ Remove the three screws from the control unit (→ Fig. 49 and → Fig. 50, pos. 1).

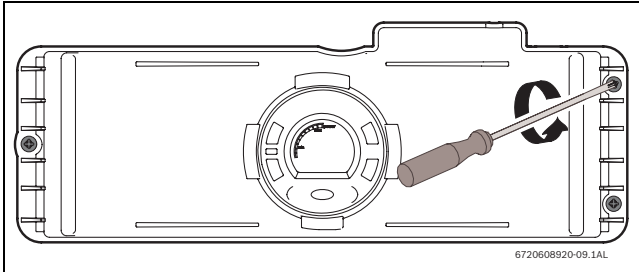

Fig. 49

- ▶ Remove the six screws from the back cover of the control unit (→ Fig. 50, pos. 2).
- ▶ Check the fuses in the printed circuit board (→ Fig. 50, pos. 3)

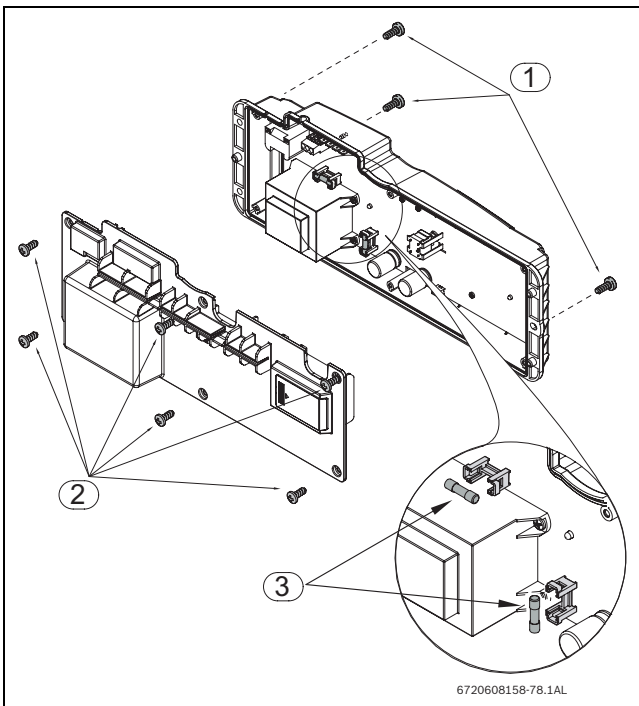

Fig. 50 Fuses position

- ▶ After checking the fuses, reinstall all parts in reverse order (→ Fig. 50, pos. 3).

8.6 INSTALLATION OF INTELLIGENT CASCADING KIT

Each appliance comes equipped with two connectors inside for the installation of the intelligent cascading kit. The connectors are labeled 'cascading input' and 'cascading output'. To access connectors, remove front cover (8.5 POSITION OF THE FUSES IN CONTROL UNIT).

Although intelligent cascading will rotate the primary appliance, it is essential to install the kit starting with the appliance that is furthest from the cold water main.

- ▶ Starting with the appliance furthest from the cold water main, connect the male end of the cascading cable to the connector inside labeled 'cascading output'.

- ▶ Feed the cascading cable to the left from the primary appliance through the hole at the bottom of the adjacent secondary appliance.
- ▶ Connect to the 'cascading input' connector of the secondary appliance (→ Fig. 51).
- ▶ Repeat this procedure for all the secondary appliances.
- ▶ Complete the circuit by connecting a cascading cable from the "cascading output" connector on the last secondary appliance to the "cascading input" connector on the primary appliance.



Cascading cables may be connected in series if one cable is not long enough.

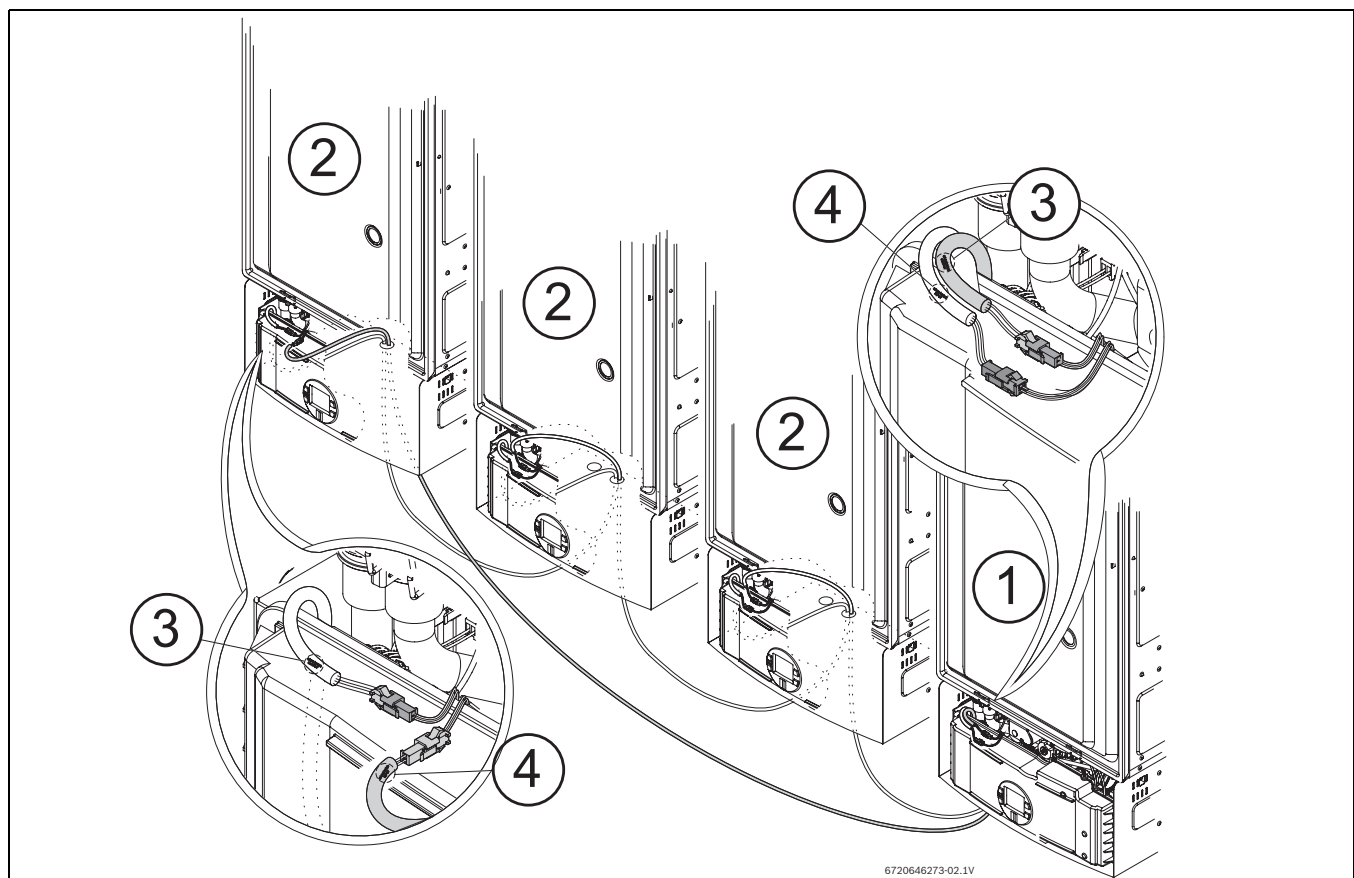

Fig. 51 Example of installation

- 1 Primary appliance
- 2 Secondary appliance
- 3 Cascading Input
- 4 Cascading Output

8.7 FUNCTIONAL REQUIREMENTS FOR CASCADE SYSTEMS

8.7.1 HOT WATER REQUESTS

When a water heater reaches 80% of its capacity, it passes on hot water requests to the next secondary water heater in the system. Secondary acts like a primary to the next secondary. When primary reach 30% of his capacity it will remove the request sent to the secondary.

8.7.2 WATER DEMAND FROM SOLAR

When the primary reads flow higher than 30 L/min and inlet temperature is higher than set point, water will flow through the appliance working with the solar function and the primary will send a hot water request to the next Secondary in the system. This way, when the appliances are in solar mode, the water flow of the cascading system will not be restricted.

This function is reset when inlet temperature reaches set point - 4°C. Appliances will get out of solar mode and restart normal operation.

8.7.3 ERROR HANDLING

When one appliance in the cascading system is locked, due to an error code, all actions are passed to the next appliance. If the appliance is a primary, it will request to the next appliance to be the primary.



Lead/lag changeover is not possible if the water heater electronics are damaged or connection is lost between the appliances. The system will stop working if the electronics in the primary are damaged. Disconnect the damaged appliance and select a new primary unit.

In this case the damaged appliance must be turn OFF and the cascading cables must be disconnect from the appliance. The two connector ends must be connected, in order to close the cascading circuit.

If the damaged appliance is the primary, another appliance must be programmed to be the primary.

8.7.4 OPERATING HOURS

The operating hours of each appliance are visible in P4 mode in menus H0, H1 and H2.

The formula to calculate the total amount of working hours is:

$H0 + (H1 \times 100) + (H2 \times 10000) = \text{Total working hours.}$

Operating hours		
Number in H0		_____ +
Number in H1	_____ (X100)	_____ +
Number in H2	_____ (X10000)	_____ +
Total of hours (H0+H1+H2)=		_____

Tab. 12

8.7.5 NUMBER OF HOURS TO ROTATE PRIMARY

The primary appliance will rotate after 100 operating hours. The rotation will take place when there is no flow through the water heater.

NOTE: In systems where a re-circulation pump is installed: ensure the pump is connected to a timer and turned off for at least 1 hour every day. This will stop flow through the water heater and allow rotation of the primary water heater.

8.7.6 TEMPERATURE SET POINT CHANGE

The set point temperature limits are the same in a cascade as in a stand alone appliance. The temperature set point is transferred from the primary appliance onto the secondary units.

8.7.7 REMOTE CONTROL USAGE

In this cascading configuration (Intelligent cascading) only one remote control is needed to change the temperature set point in the system. If the set point is changed in appliance the set point will be updated in all appliances within 2 seconds.

The error code for the remote control is only displayed in the appliance where the base unit is installed.

The base unit can be installed in any appliance, regardless whether it is primary or secondary.

9 COMMISSIONING

9.1 FACTORY REGULATIONS



Sealed components must not be opened.



DANGER: Serious personal injury!

- ▶ The following operations must be carried out by a qualified and registered Gas engineer.

NATURAL GAS

The water heaters are designed for use with natural gas (G20) and are pre-commissioned for operation with that gas type.



Ensure that the inlet pressure is satisfactory with all other gas appliances working.

LPG

The water heaters are designed for use with LPG (G31) and are pre-commissioned for operation with that gas type.



NOTICE:

- ▶ Ensure that the gas inlet pressure is satisfactory with all other gas appliances working.
- ▶ Do not continue with the other checks if the correct gas inlet pressure can not be achieved.

- ▶ Check the gas supply working pressures in the system conform to the readings shown in the table below:

Natural gas					
Allowed mbar pressure drop					
meter / regulator	across pipework	gas isolation valve	heater inlet	across heater	gas control valve
19 - 23	1	0.5	18 - 22	2	16 - 20

Tab. 13

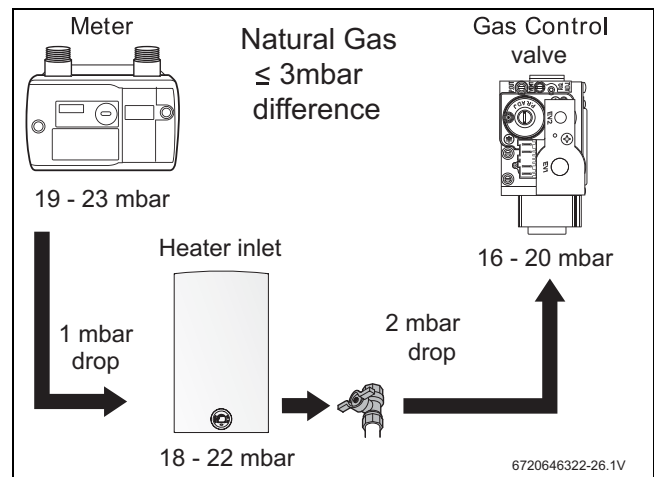

Fig. 52

L.P.G.					
Allowed mbar pressure drop					
meter / regulator	across pipework	gas isolation valve	heater inlet	across heater	gas control valve
32 - 45	2.5	0.5	29.5 - 42.5	2	27.5 - 40.5

Tab. 14

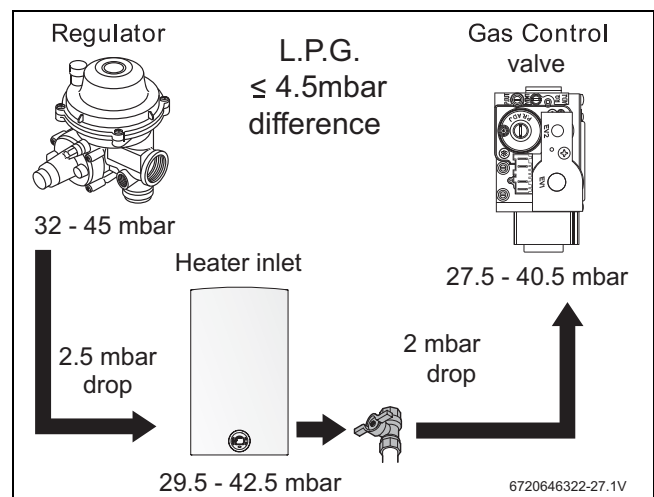

Fig. 53

9.2 MEASURING GAS PRESSURE

Confirm gas pressure after installation.

CONNECTING GAS PRESSURE GAUGE

- ▶ Shut off gas supply.
- ▶ Remove the front cover (→ Fig. 24).
- ▶ Loosen screw inside left test point fitting (do not remove) and connect gas pressure gauge tube to test point.

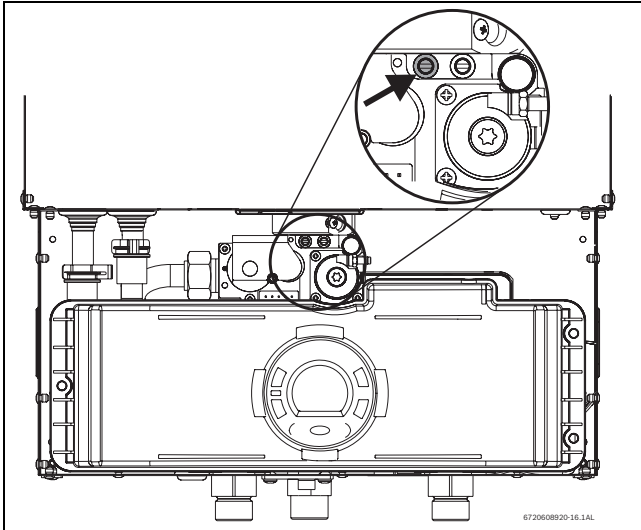

Fig. 54 Gas pressure test point (left test point)

STATIC PRESSURE TEST

- ▶ Turn gas supply back on.
- ▶ Record static gas pressure reading in table 15.

Static Gas Pressure Reading	
Pressure: _____	Date: _____
Operating Gas Pressure Reading	
Pressure: _____	Date: _____

Tab. 15

OPERATING PRESSURE TEST

- ▶ Press ON/OFF button to turn off the appliance.

- ▶ Press and hold "Program" button and press ON/OFF button to turn appliance ON (→ Fig. 55).

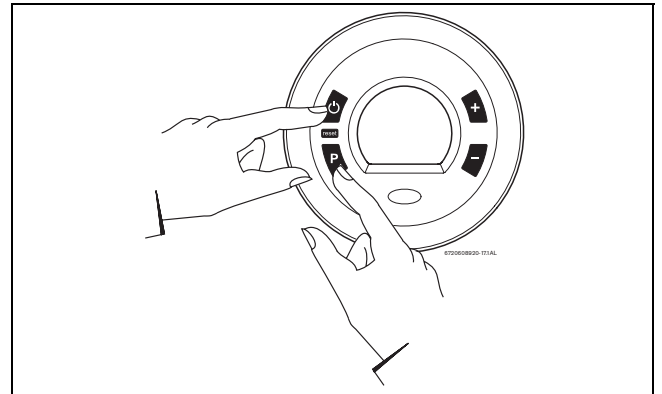

Fig. 55 Gas setup mode

- ▶ As soon as '188' is displayed, release "Program" button **P**, and the display reads P2.
- ▶ Press **+** or **-** until P1 appears.



NOTE: While in this mode, the appliance will run constantly at maximum output and allow maximum water flow.

For inlet gas pressure adjustment see values in table 16:

Gas type	NG	Propane
mbar	20	37

Tab. 16

- ▶ Turn on high volume of hot water flow (at least 15 l/m) and burner will light. If heater display reverts to P2, open more hot water draw off points to allow sufficient flow. Press **+** until P1 reappears on the display.
- ▶ Operate all other gas appliances on same gas supply at maximum output.
- ▶ Record lowest operating gas pressure reading in table 15.
Gas pressures lower than 20 mbar for Natural Gas or 27-30/37 mbar for LPG will result in reduced temperature rise to the hot water being used, reduced hot water volume, possible error code faults and must be corrected.
Check gas pipes dimensions.

9.3 ADJUSTING CO₂ (CARBON DIOXIDE)



The CO₂ shall only be adjusted by a Gas Safe registered installer with a calibrated CO₂ analyzer.

CAUTION: Insufficient gas pressure
May affect CO₂ levels.

- ▶ Check and adjust gas pressure (→chapter 9.2).

WHEN THE GAS PRESSURE IS CORRECT:

- ▶ Press ON/OFF button to turn off the appliance.
- ▶ Remove brass flat head screw on the flue gas connector (→ Fig. 56).

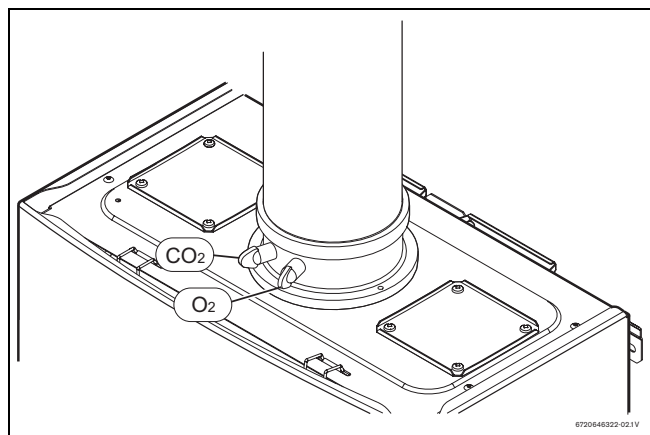

Fig. 56 Measuring port

- ▶ Insert CO₂ analyzer probe into the test point. The tip of the probe should be in the center of the flue pipe (inserted approximately 60mm). Avoid air gaps between probe and measuring port as they can alter readings.
- ▶ While holding the Program (P) button, press the ON/OFF button to turn ON the heater (→ Fig. 57).

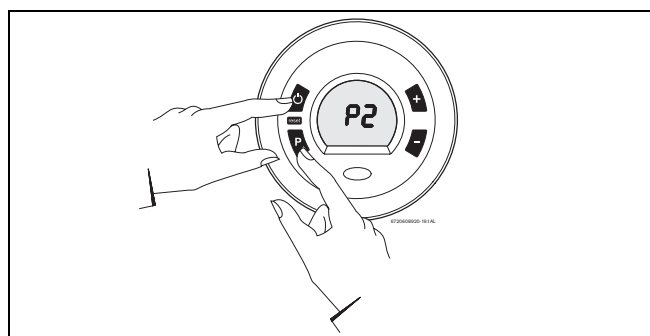

Fig. 57

- ▶ While holding the Program **P** button, press the ON/OFF button to turn ON the heater. As soon as '188' flashes on the display, release the Program button. The display should now read P2.
- ▶ Press **+** or **-** button until "P1" appears on display.

MEASURING CO₂ (COMBUSTION COVER INSTALLED):

- ▶ Open all hot water taps to achieve a flow rate of at least 15 l/m (1 tub and 2 sinks are usually sufficient). If heater display reverts back to P2, open more hot water fixtures to allow sufficient flow.
- ▶ Press **+** until P1 reappears on the display.

- ▶ Record the CO₂ reading in P1 in the table 17. Analyzer reading may take several minutes to stabilize.
- ▶ Press **+** button until P2 appears. Unit will ramp down to low fire and the water flow should decrease.

Program	CO ₂ values
P1	_____ %
P2	_____ %

Tab. 17

ADJUSTING CO₂

i **Note: P1 adjustment will change the P2 reading. Confirm the P1 value BEFORE adjusting the P2 level.**

If P1 CO₂ level is out of range:

- ▶ Loosen yellow painted philips screw (→ Fig. 58, pos. 1) and cover should rotate down (→ Fig. 58, pos. 2) revealing a recessed brass slotted screw. (→ Fig. 58, pos. 3).
- ▶ Turning the slotted screw counter clockwise. P1 CO₂ levels, will increase.
- ▶ Turning the slotted screw clockwise. P1 CO₂ levels, will decrease.

i Adjustments to the slotted screw (P1) will also change P2 CO₂ levels.

- ▶ After bringing the P1 CO₂ readings in proper range, press the **+** button to enter the P2 mode.
- ▶ Verify CO₂ readings in P2 mode.

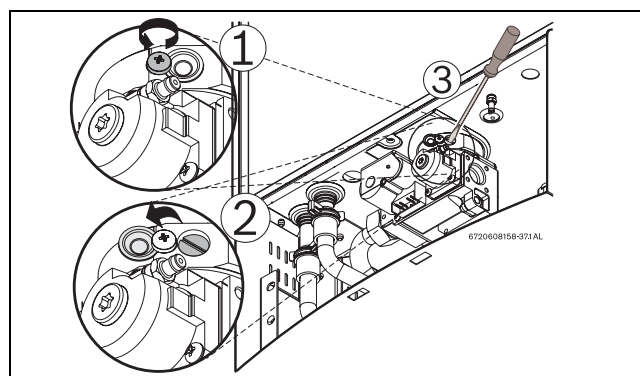

Fig. 58 Adjusting P1 CO₂ level

If P2 CO₂ level is out of range:

- ▶ Remove yellow painted #40 Torx cover from the front of the gas valve (→ Fig. 58). A plastic #40 Torx screw will be revealed.
- ▶ Turning the plastic #40 Torx screw counter clockwise. P2 CO₂ levels will decrease.

- ▶ Turning the plastic #40 Torx screw clockwise. P2 CO₂ levels will increase.



Note: This screw adjustment is very sensitive and should be made in small increments. It may take several minutes for readings to stabilize.

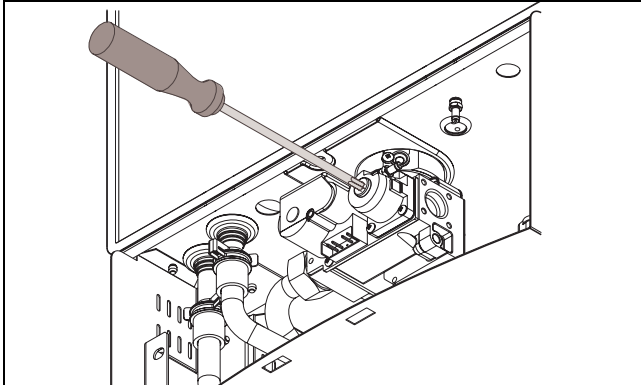

Fig. 59 Adjusting P2 CO₂ level

- ▶ Verify both P1 and P2 CO₂ readings are within the ranges specified in table 18.
- ▶ Repeat steps 1 and 2 as necessary until CO₂ values are within the specified ranges.
As soon as the levels of CO₂ are correct, verify the values of CO corresponds to the limits of the table 18. If the values exceed the limits, it is necessary to verify the ventilation system and heat exchanger.

		CO ₂ range (%)	Max. CO level (measured)
Natural gas			
Max.	P1	8.1% - 8.9%	< 200 ppm
Min.	P2	2.0% - 2.6%	< 30 ppm
Propane			
Max.	P1	9.2% - 10%	< 250 ppm
Min.	P2	2.0% - 2.6%	< 30 ppm

Note: Values above are for controlled climate conditions. Inputs such as gas pressure, heating value of the gas, humidity and temperature of combustion air impact CO and CO₂ values. Changes in these inputs can result in different CO and CO₂ values on the same appliance.

Tab. 18 CO₂ & CO target numbers

END OF ADJUSTMENTS

- ▶ Record the final values in table 19.

Program	CO ₂ values measured	Date
P1	_____ %	
P2	_____ %	

Tab. 19

Reassemble all parts in reverse order:

- ▶ Return slotted screw cover to original position and tighten the philips screw (→ Fig. 58).
- ▶ Reinstall Torx protection cover (→ Fig. 59).
- ▶ Remove CO₂ analyzer probe and reinstall flathead screw with gasket in exhaust collar.
- ▶ Press ON/OFF button to turn OFF the heater.
- ▶ Press ON/OFF button to turn ON the heater. Heater is ready for normal operation.

9.4 PROGRAM VALUES

This section describes details on programming the appliance. For most applications the factory default values will provide robust and stable operation.



CAUTION: Misadjusted program values can lead to appliance malfunction, errors, and service calls.

Program	Description	Factory default	Min	Max	Comment
P1	Maximum Power	N. Gas: 45 Propane: 42	21	N. Gas: 45 Propane: 42	See chapter 9.2. Note: reducing P1 values below maximum will reduce maximum power of the appliance.
P2	Minimum Power	12	12	20	See chapter 9.2.
P3	Remote Controls installed	_0	_0	6	See chapter 9.8.
P4	Access to Diagnostic Mode	E	0d	10f	See chapter 9.6.
P5	Cascade Mode	NO	NO	CC	To activate the cascade mode it's necessary to install the "kit cascade" (part number 7 736 500 272)
P6	Temperature Unit	°C	°F	°C	See chapter 9.6.
P7	Appliance Type	Cd (Condensing)	Cd (Condensing)	nC	Condensing / Non-condensing Note: incorrect setting will cause errors.
P8	Back light	dE	dE	ON	dE : turns back light off after 60 seconds from last button pushed. ON: turns backlight on permanently.
P9	Fan Purge				Runs secondary fan and primary fan when P9 is selected by depressing the "P" - button
PH	Cascading type	IC (Intelligent Cascade)	IC (Intelligent cascade)	SC (Simple cascade)	This menu is only available when cascade mode (Program P5) is selected CC.
PC	Master/Slave mode	CS	CS	CM	

Tab. 20

9.5 APPLIANCE CASCADING MODE SETTING



Perform this procedure on all appliances in the cascading set up.



All appliances in the installation must be adjusted to the same outlet water temperature. By selecting on any appliance all the others will update the set temperature accordingly.

- ▶ Push ON/OFF switch to the OFF position.
- ▶ Press and hold the program button **P** and then press the ON/OFF button to the ON position. As soon as '188' flashes on the display, release the **P** button.
 - **The display should now read P2.**
- ▶ Press the **+** button until P5 appears.
- ▶ Press Program button **P**.
 - **The display should now read NC (normal mode).**
- ▶ Press **+** button until CC (cascading mode) appears.
- ▶ Press and hold Program button **P** until CC blinks on the display.
- ▶ To enter in the main menu, press **P** button.
 - **After the “CC” is selected, two new menus will become available in the main menu, PH and PC.**

To access PH and PC menu,
- ▶ Press the **+** button until PH or PC appears.

PC - PRIMARY AND SECONDARY SELECTION

- **CM** - Primary
 - Only one appliance in the cascading system should be selected as “Primary”.
- **CS** - Secondary (default)
 - The others appliances in the cascading system must be “Secondary”.

PH - CASCADING MODE SELECTION

- **IC** - Intelligent Cascading (default)
 - The primary will rotate after 100h/work.
- **SC** - Simple Cascading
 - There will not be any primary rotation when this appliance is selected as primary.



Selection is done pressing the button **P** until the display starts flashing.

The appliance is now programmed to operate in the cascading mode.

9.6 CONTROL BOARD DIAGNOSTICS

To access the diagnostic menu, proceed as follows:

- ▶ Press ON/OFF button to turn off the appliance.
- ▶ Press and hold "Program" **P** button and press ON/OFF button to turn appliance ON.
- ▶ Release the **P** button when '188' appears on the display. The display should read 'P2' when the program button is released. If not, repeat process.
- ▶ Press and release the **+** button on the control panel until the display reads 'P4'. You are now in the diagnostic mode of the control board.
- ▶ When the display reads 'P4', press and release the **P** button once again and the display should read 'E'.
- ▶ Use the **+** or **-** button on the control board to cycle through different diagnostic modes available.
- ▶ Once in the selected diagnostic mode of your choice, press and release the **P** button to display the diagnostic information.

Example: to read the flow rate in litres per minute while there is a flow of water through the appliance, cycle to the '3d' mode and press the **P** button. A reading of 15 on the display would indicate the heater is reading a flow rate of 15 litres/minute.

Once the information is obtained,

- ▶ Press the **P** button again to return to the diagnostic mode menu.
- ▶ Press **+** or **-** buttons until the letter "E" appears on the display, to leave the diagnostic menu.
- ▶ Press **P** button and in the display appear 'P4'.
- ▶ Press ON/OFF button to turn off the appliance.
- ▶ Press ON/OFF button to turn ON the appliance. Water Heater is ready for normal operation.

Diagnostic menu	
E	Entry/Exit into sub-modes
0d	Set-point temperature (°C)
1d	Inlet water temperature (°C)
2d	Outlet water temperature (°C)
3d	Water flow (l/min) (gallons/min)
4d	Gas type (LP or NG)
5d	Fan speed (Hz)
6d	Burner power (%)
7d	Maximum power (kW)
8d	Back flow temperature (°C)
9d	Flue gas temperature (°C)

Tab. 21

Diagnostic menu	
1F	Most recent error/failure
2F	2nd most recent error
3F	3rd most recent error
4F	4th most recent error
5F	5th most recent error
6F	6th most recent error
7F	7th most recent error
8F	8th most recent error
9F	9th most recent error
10F	10th most recent error
H0	Numbers of hours - mode 0
H1	Numbers of hours - mode 1
H2	Numbers of hours - mode 2

Tab. 21



When 'OO' appears on the display, this means that 'no error' has occurred.

9.6.1 WORKING HOURS

To see how many hours the appliance has worked, please enter the "Diagnostic menu";

- ▶ Select the sub-mode "H0".
Write the number that shows in the display.
- ▶ Select the sub-mode "H1".
Write the number that shows in the display.
- ▶ Select the sub-mode "H2".
Write the number that shows in the display.

After checking the sub-modes H0, H1 and H2, introduce the values in the table below;

Working hours		
Number in H0	_____	_____ +
Number in H1	_____ (X 100) =	_____ +
Number in H2	_____ (X 10 000) =	_____ +
(H0 + H1 + H2) = Total of hours		_____

Tab. 22

9.7 FAN SPEED ADJUSTMENT

The maximum flue length when using the condensit 80/125 flue gas system is 8 metres.





In all cases, the equivalent flue length calculation and fan speed adjustment must be carried out.



After installing the appliance, the minimum power fan speed must be adjusted to compensate for variation in flue pipe length.

Before adjusting the fan speed it is necessary to verify the flue gas system, calculating the total length of the flue pipes and quantity of elbows.

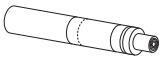
Pressure drop equivalence of the flue pipes and flue accessories.

Equivalence in meters Ø80/125mm		
Description	Ø80/125mm	Length (m)
7-719-003-665		1.5
7-719-003-664		2.0
7-719-003-702		0.4 to 0.6 (dependent on actual length)
7-719-003-666		1.0
7-719-002-431		1.4

Tab. 23 Equivalent length

9.7.1 CALCULATION OF THE CONCENTRIC FLUE PIPE LENGTH Ø80/125 MM

How to calculate the total length of the concentric flue pipes:

- ▶ Determine the total length of the concentric flue pipes and enter in table 24, line 1.
- ▶ Count the number of 90° elbows used, multiply by 2m, and enter that value in table 24, line 2.
- ▶ Count the number of 45° elbows used, multiply by 1.5m, and enter that value in table 24, line 3.



Do not count terminals and first elbow.

Concentric flues			
1	Straight section length	__ x 1 =	_____
2	90° elbows (qty)	__ x 2 =	_____
3	45° elbows (qty)	__ x 1.5 =	_____
4	Total equivalent flue length=		_____

Tab. 24

EXAMPLE

Concentric conduct:

- 4 units of 1m straight sections
- 1 unit of 1m straight section
 - Total length = 5 meters
- 2 - 90° elbows

EXAMPLE TABLE:

Concentric conduits			
1	Straight section length	5 x 1 =	5
2	90° elbow (qty)	_1_ x 2 =	2
3	45° elbow (qty)	_0_ x 1.5 =	0
4	Sub-total:		7

Tab. 25

Note: Do not count terminal and first elbow.



Total maximum length for concentric flue pipes must not exceed 8 meters.

9.7.2 ADJUSTING FAN SPEED

After obtaining the total sum of the flue pipes, proceed as follow:

- ▶ Press ON/OFF button into OFF.
- ▶ Press and hold "Program" button and press ON/OFF button to turn appliance ON (→ Fig. 60).

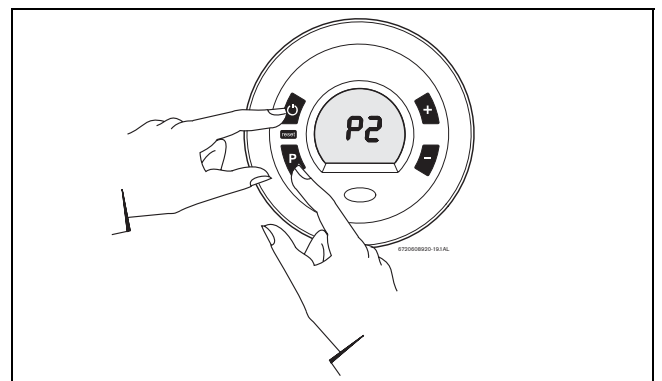



Fig. 60

- ▶ As soon as '188' is displayed, release "Program" button  , and the display should read P2.

- ▶ Press one time **P** to access the program P2. In the LCD display is visible the attributed value (factory value: 12).
- ▶ Press **+** or **-** to choose the fan speed suitable with your installation, see tab. 26 for concentric conducts Ø 80/125 mm.
- ▶ Press and hold (± 5 sec.) "Program" button **P** until the display flashes. Selected value is memorized.

FAN SPEED FOR CONCENTRIC FLUE Ø80/125 MM

Mode	Flue length ¹⁾	Fan speed
P2	From 1 m until 3 m	12
	from 3.1 m until 7 m	13
	from 7.1m until 8 m	14

Tab. 26

1) Total flue lengths of table 24 do not count with the first elbow and the horizontal flue kit.



Do not set P2 to greater than 14.

9.8 REGISTRATION OF REMOTE CONTROL

Only a qualified technician is allowed to install the additional PCB that is supplied with the remote (part number: 7709 003 736). Registration can only be made after installation on the PCB. The registration of the remote control must be done near the appliance.

Turn off the hot water tap.

Turn OFF the appliance (Fig. 8, pos.1).

- ▶ Press and hold the programming button (Fig. 8, pos.3), press ON/OFF button (Fig. 8, pos. 1) to connect the appliance. Release programming button only when LCD displays "188". The LCD displays the signal "P2".
- ▶ Press button **+**, until it displays the signal "P3".
- ▶ Press programming button again for about 1 second. LCD panel displays one number and one rotating digit. The number represents the remote control which is to be registered, the first remote control will be registered with number "0", the second with number "1" and so on.
- ▶ Test the remote control in front of the electronic box by simultaneously pressing the **+** and **-** control buttons.



NOTE: up to 6 remote controls can be connected to a single water heater, each with a range distance of 30m.

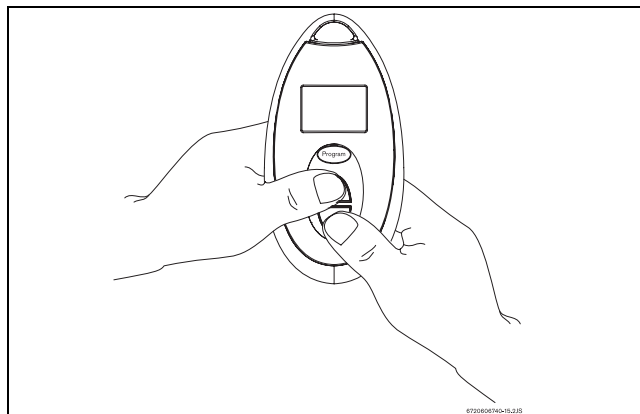

Fig. 61 Activate new control

- ▶ Press both buttons on the remote control until the LCD panel stops flashing and shows the indication "00".
- ▶ Press ON/OFF button (→ Fig. 8, pos. 1) to disconnect the appliance. Remote control is now activated.



Press the ON/OFF button to turn ON the remote control and it's ready to work.

9.9 REMOTE CONTROL OPERATION

This appliance fulfills European directive requirements 1999/5/CEE (R&TTE) and corresponds to the specifications described in the corresponding CE certificate of proof.



- ▶ Press buttons **+** and **-** in order to reach requested temperature.

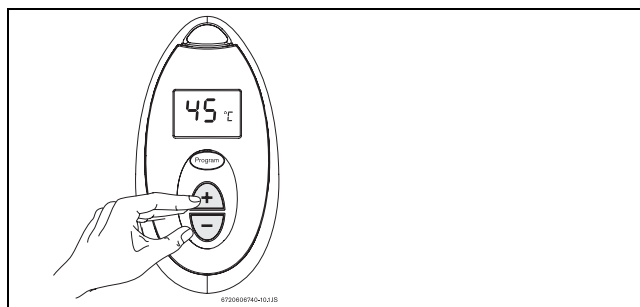





Fig. 62 Remote control (temperature selection)

CAUTION:
 This remote control must only be operated by a responsible adult who has been instructed in, understands, and is aware of the water heater's operating conditions.

BATTERIES REPLACEMENT

- ▶ Remove the 2 screw from the remote control back.
- ▶ Open the cover.
- ▶ Remove the old batteries and replace with new ones.
- ▶ Close the remote control assuring that both screws are tighten screwed.

CAUTION:
 Remote control damage!
 ▶ The remote control can be used in a shower , however do not submerged the remote control in water .

PRECAUTIONS WHEN USING THE BATTERIES

- Do not dispose of batteries as domestic waste. Take them to appropriate collecting places for recycling.
- Do not insert flat batteries.
- Only use the type of batteries indicated.

9.10 PROGRAM BUTTON

Program button can be used in the appliance and in the remote control.

"PROGRAM" FUNCTION

i Each remote control program button can be programmed with different temperature values according with the user needs. A temperature value can be programmed in the remote control and another value in the appliance.

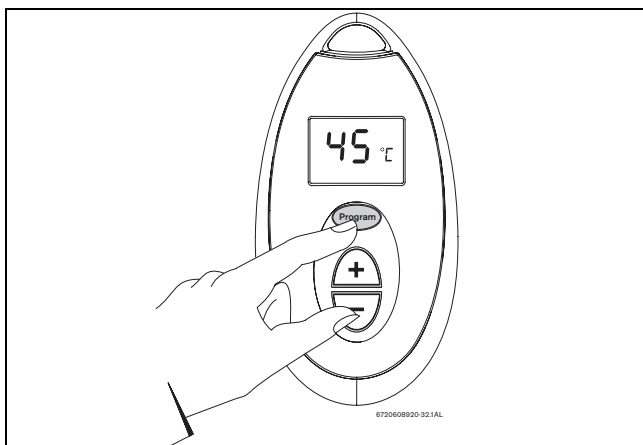

Fig. 63 "Program" key

- ▶ Press buttons  and  to select temperature to be memorized.

- ▶ Press "Program" button for 3 seconds to save temperature.
 The temperature is saved on "Program" when the LCD panel stops blinking.

USING "PROGRAM" FUNCTION

In order to select memorized temperature:

- ▶ Press "Program" button.
 LCD shows pre-memorized temperature, which is now the selected hot water temperature.

9.11 "PRIORITY" FUNCTION

i PRIORITY is a function to prevents the user from accidentally altering the water temperature selected by another user.

The appliance does not have a default priority.

Priority is given when the first user selects a temperature (→ chapter 5.4).

The following symbol appears for other users .



The priority user may change the initial selection at any time.

Non-priority users cannot change the selection made by the priority user.

The system resets priority function 5 minutes after last water demand, returning to the initial state.

TO SELECT PRIORITY

Any user may select temperature selection priority in the following manner:

- ▶ Press one of the selection buttons  or  for 5 seconds.

i Priority cannot be selected when the appliance is working.

10 SERVICE AND SPARES

To ensure the appliance correct functioning we recommend an annual inspection or if necessary maintenance.



Your appliance must only be serviced by a qualified service engineer.



DANGER:

- ▶ ISOLATE THE MAINS GAS SUPPLY BEFORE STARTING ANY WORK AND OBSERVE ALL RELEVANT SAFETY PRECAUTIONS.



NOTICE: COMPONENTS

- ▶ After replacement of any components always check for gas tightness. Where relevant carry out functional checks as described in the commissioning section. Damaged O-rings or gaskets must be replaced.



NOTICE:

- ▶ Service work must be carried out by a competent registered engineer.



NOTICE:

- ▶ SERVICE MUST **NOT** BE ATTEMPTED IF A CO/CO₂ ANALYSER IS **NOT** AVAILABLE.

- ▶ Use only genuine spare parts.
- ▶ Order accessories according to the list of spare parts provided with the appliance.
- ▶ Substitute dismantled joints and o-rings with new ones.
- ▶ Only the following lubricants must be used:
 - On hydraulic parts: Unisilikon L 641 (part number 8 709 918 413)
 - Threaded joints: HFt 1 v 5 (part number 8 709 918 010)

10.1 PERIODIC MAINTENANCE TASKS

FUNCTIONAL CHECKS

- ▶ Ensure that all safety, regulatory and checking components are in good working order.

HEAT EXCHANGER

- ▶ Inspect the heat exchanger.
- ▶ If it is dirty:

- Dismantle the combustion chamber and remove the heat exchanger overheat thermostat (→ Fig. 2 [8]).
- Clean the chamber with a pressurized water jet.
- ▶ If the dirt resists: soak soiled parts in hot water with detergent and clean carefully.
- ▶ If necessary: de-scale the interior of the heat exchanger and connection tubes.
- ▶ Reassemble the heat exchanger using new gaskets and o-rings.
- ▶ Remount the heat exchanger overheat thermostat on its support.

BURNER



WARNING: Burner damage!

The burner surface is very fragile.

- ▶ Do not touch the burner surface, take extra caution during the maintenance operations!

- ▶ Inspect the burner annually and clean if necessary.
- ▶ If it is very dirty (grease, soot): Dismantle the burner and soak it in hot water with detergent and clean it carefully.
- ▶ Verify if the flame is stable and blue without signs of yellow flames.



Yellow burner flames are an indication of improper combustion. Check flue termination and ventilation in line with the manufacturer's instructions.

- ▶ Verify CO₂ levels (→ chapter 9.3) and adjust if necessary.

WATER FILTER

- ▶ Close the water inlet valve.
- ▶ Dismantle the cold water inlet pipe (→ Fig. 64).

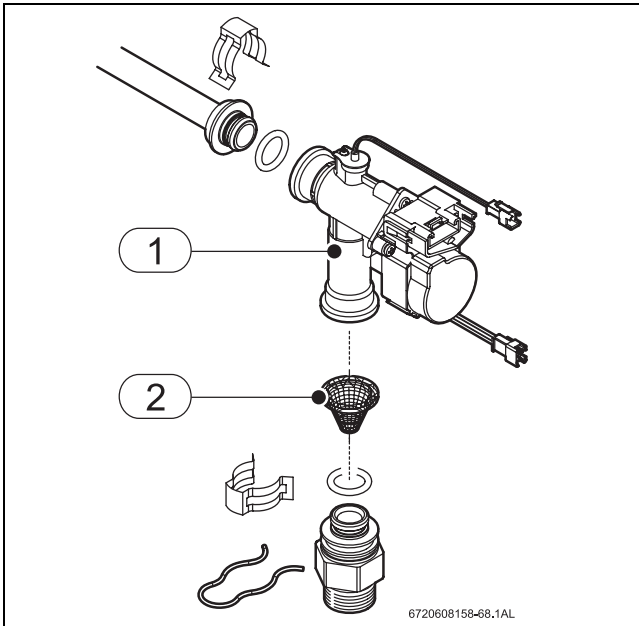

Fig. 64

- 1 Motorized water valve
- 2 Water filter

- ▶ Clean the water filter.

INLET WATER VALVE FILTER

- ▶ Close the water inlet valve.
- ▶ Remove the water valve filter (→ Fig. 65).

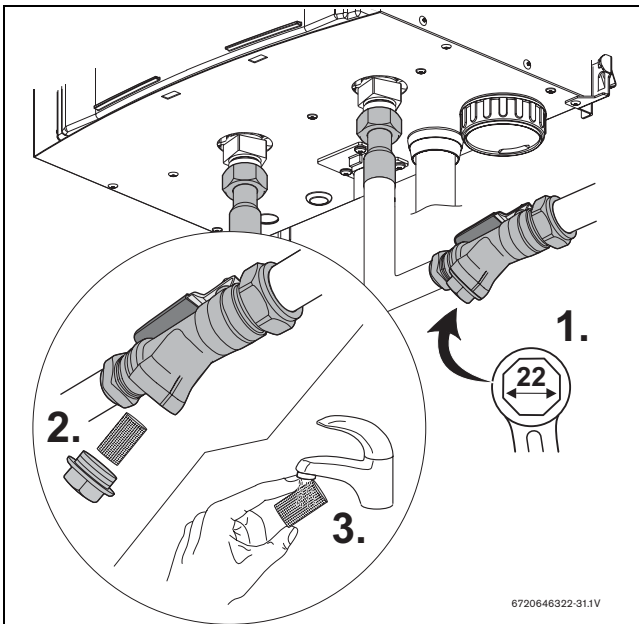

Fig. 65

- ▶ Clean the water filter.

10.2 CHECK THE FUSES IN THE CONTROL BOARD

To check fuses, proceed as follows;

- ▶ Remove the front cover (→ Fig. 24).
- ▶ Remove the three screws from the control unit (→ Fig. 66 and Fig. 67, pos. 1).

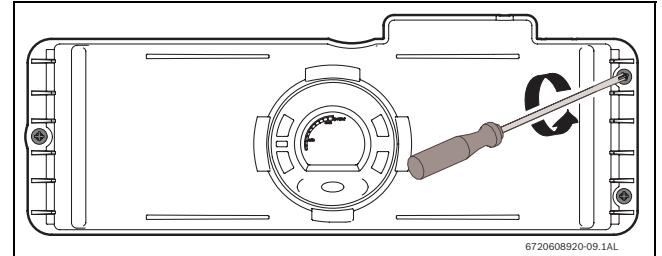

Fig. 66

- ▶ Remove the six screws from the back cover of the control unit (→ Fig. 67, pos.2).

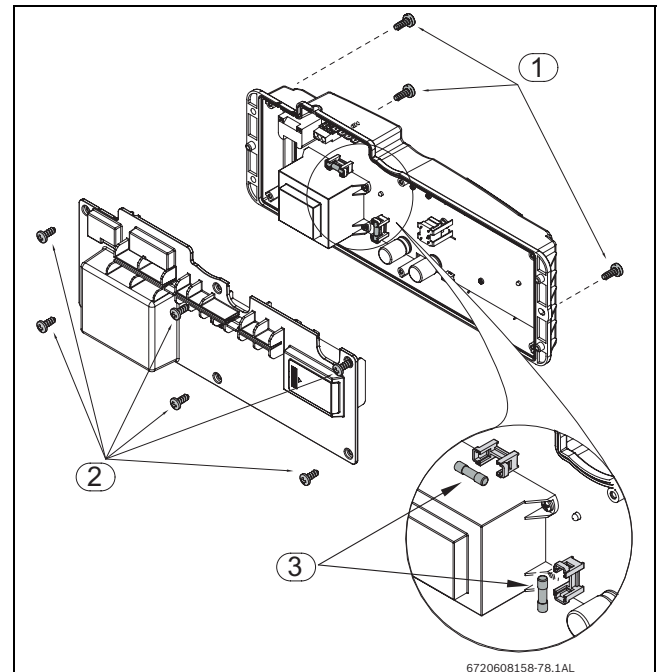

Fig. 67 Location of the fuses inside the control board

- ▶ After checking the fuses, reinstall all parts in reverse order.

10.3 CONDENSING HEAT EXCHANGER UNIT



The condensing heat exchanger unit must be checked once a year. Only a qualified engineer should inspect and maintain the condensing heat exchanger.

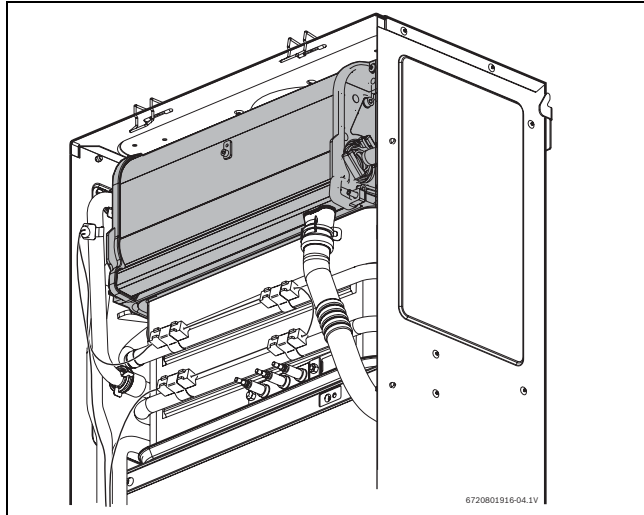

Fig. 68 Condensing heat exchanger unit

CONDENSING HEAT EXCHANGER UNIT MAINTENANCE;

- ▶ Shut off power. Disconnect power cord.
- ▶ Close cold water supply inlet isolation valve and open a hot water tap to release pressure and drain.
- ▶ Disconnect the condensate tube (→ Fig. 69, pos.1) and all inlet, outlet pipes (→ Fig. 69, pos.2) from the condensing heat exchanger unit.
- ▶ Remove two hex screws (→ Fig. 69, pos. 3) and two Philips screws (→ Fig. 69, pos. 4).

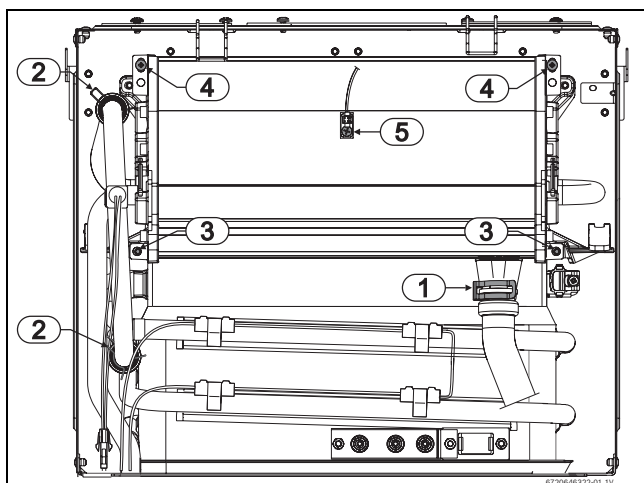

Fig. 69 Removing the condensing heat exchanger

- ▶ Remove the condensing heat exchanger unit from the appliance by pulling it towards you.

- ▶ Flush, clean and inspect condensing heat exchanger. If deterioration is detected or dirt can not be removed, dismantle all parts of the heat exchanger for detailed inspection and cleaning.

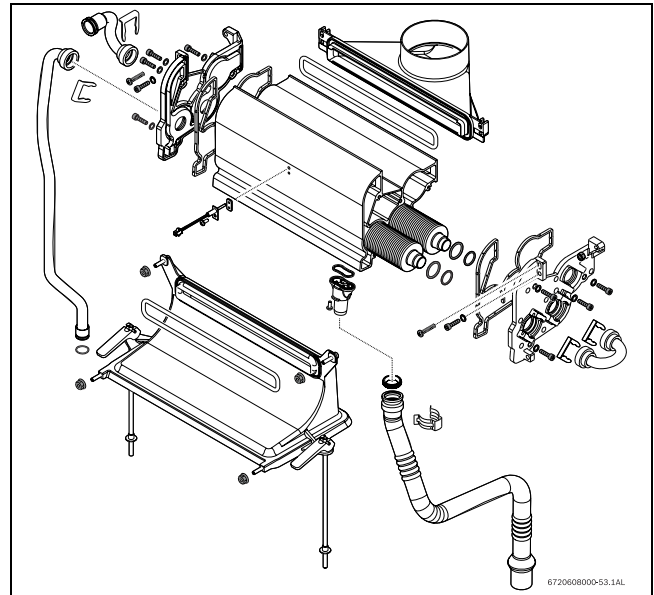

Fig. 70 Condensing heat exchanger

- ▶ Check the condensing heat exchanger for any obstruction.
- ▶ Flush the condensing heat exchanger unit with water.
- ▶ Replace all gasket and o-rings.



If the heat exchanger is dismantled, it is mandatory to replace the gaskets and o-rings (use part number 8-704-701-116-0).

- ▶ Assemble the condensate unit and all other parts in reverse order of disassembly.

10.3.1 CLEANING THE CONDENSATE TRAP



WARNING: Material damage!

- ▶ Place a suitable container underneath the appliance before unscrewing the condensate trap cover.

To clean the condensate trap proceed as follow;

- ▶ Open the condensate trap cover.

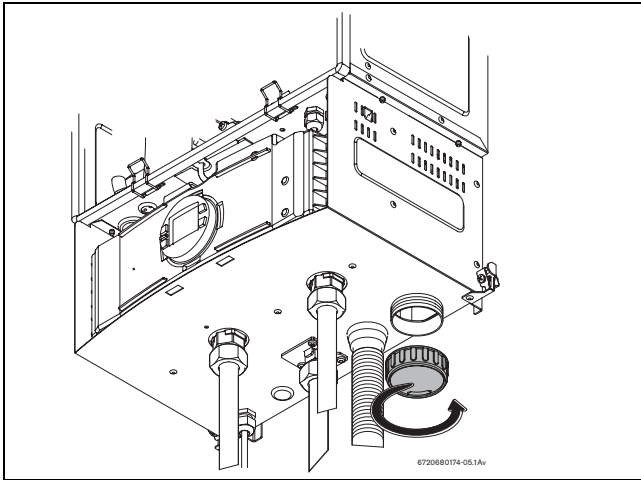

Fig. 71

- ▶ Check and clean the condensate trap with clean water.
- ▶ Screw the condensate trap cover back on.

10.3.2 FILLING THE CONDENSATE TRAP AFTER THE MAINTENANCE WORKS

After the condensate trap maintenance, it's necessary to fill it with water.

Proceed as follow;

- ▶ Remove the clip and disconnect the drain tube (→ Fig. 72).

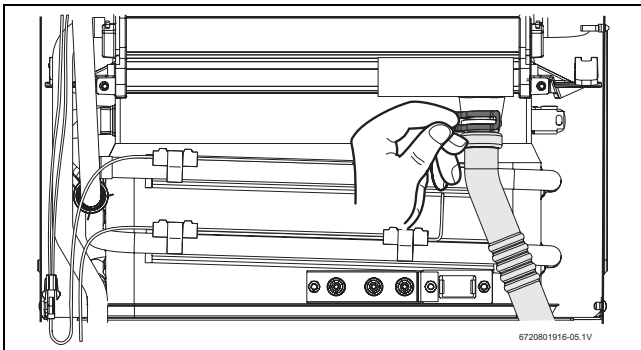

Fig. 72

- ▶ Fill the condensate trap by pouring approx. 400ml of water into the top of the drain tube. To avoid damage to the appliance use a funnel in this operation (→ Fig. 73).

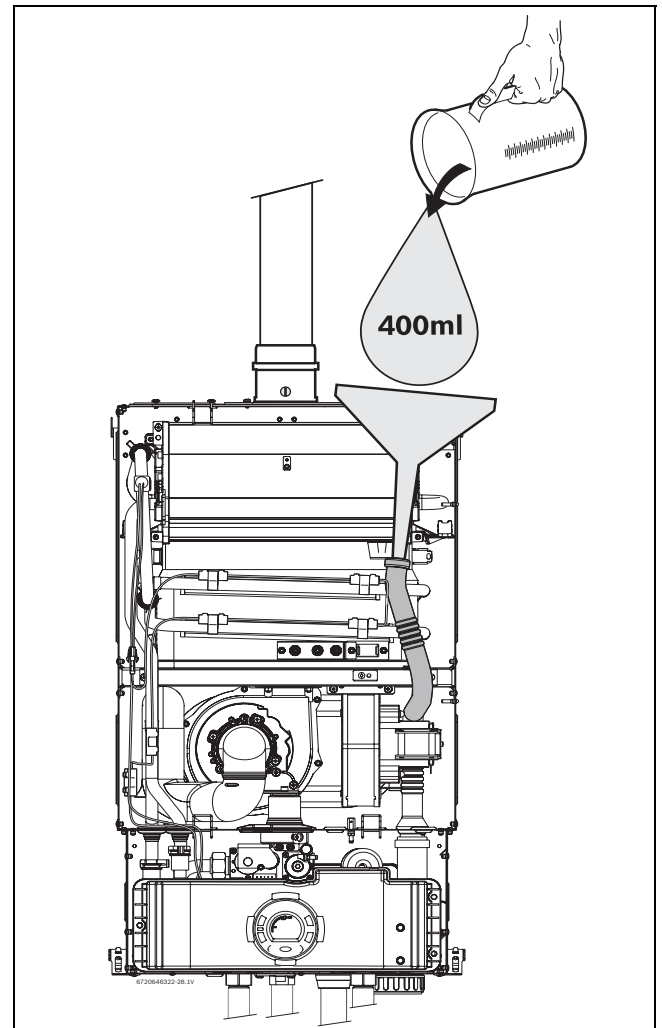

Fig. 73 Filling the condensate trap after installation.

- ▶ Loosen the three screws of the control unit (→ Fig. 66).
- ▶ Put the control unit in service position by engaging its tabs with the holes in the bottom horizontal sheet metal (→ Fig. 74).

- ▶ Check water level in the condensate trap (→ Fig. 74).

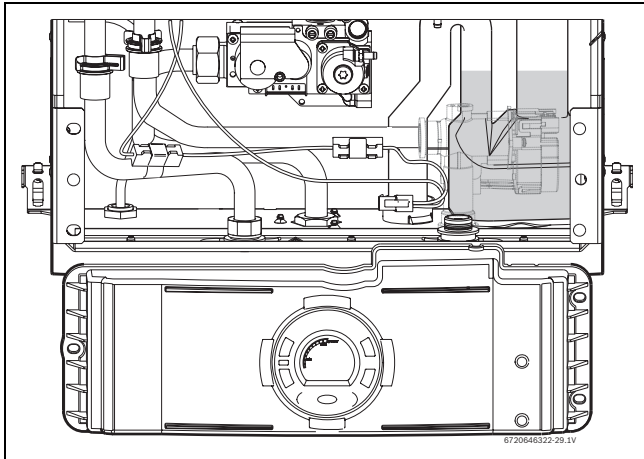

Fig. 74

- ▶ After filling reassemble all parts in reverse order.

10.4 STARTUP AFTER MAINTENANCE





- ▶ Check all water and gas joints.
- ▶ Read chapter 5 "Operating instructions" and/or chapter 9 "Installation instructions".
- ▶ Check gas pressure (burner pressure).
- ▶ Make sure combustion cover is securely fastened.
- ▶ Ensure the exhaust vent adaptor is properly sealed.
- ▶ Check for gas tightness.
- ▶ Check for water tightness.

11 FAULT FINDING AND DIAGNOSIS

11.1 FAULT FINDING









To remove error code from the display, press the reset button.

Display	Cause	Solution
	Fault in the flue temperature sensor. Temperature above 110 °C inside the cabinet.	<ol style="list-style-type: none"> 1. Check continuity of the flue temperature sensor (normally closed).* 2. Check for flue gas tightness around the top and bottom seals of heat exchanger, use mirror to check around the rear as well as the viewing window. 3. Check flue requirements are met. Long flue lengths, flueing with more than three elbows, blocked flue gas pipe or cross ventilation may cause this fault. 4. Check that flue temperature sensor connector and spade connections are secure.* 5. Disconnect water heater from electrical supply and check the wiring harness connections on the control board.
	Flue gas temperature sensor - Fault occurs if sensor is disconnected or in short circuit or appliance selection in "P7" mode is not correct.	<ol style="list-style-type: none"> 1. Check flue gas temperature sensor connection (→ Fig. 2, pos. 9). 2. Check sensor (< 100 ohm = short circuit).* 3. Check "P7" mode: The correct selection is "Cd".*
	Burner backflow temperature sensor defect - fault occurs if sensor is disconnected or in short circuit.	<ol style="list-style-type: none"> 1. Check burner backflow temperature sensor connection (→ Fig. 2, pos. 13). 2. Replace flue gas temperature sensor.*
	Outlet temperature sensor fault (Temperature below 0°C or above 98°C).	<ol style="list-style-type: none"> 1. Check red wire connections at hot water temperature sensor. Clean terminals. If badly corroded, replace sensor and wire harness.* 2. Sensor may trip if water temperature drops below 0°C to protect heater from freezing conditions. Any damage caused by freezing conditions is not covered by the warranty. 3. Clean the water filter, and any dirt in the taps and also the water filters in the installation. 4. In areas where water has a high mineral content, periodic descaling may be necessary.* 5. Check sensor.





Tab. 27

* By qualified registered gas engineer only.

Display	Cause	Solution
(Flashing) 	Hot water outlet temperature sensor not sensing expected output temperature. (Status message, not a fault code).	<ol style="list-style-type: none"> 1. Check that the sensor is firmly attached to the vertical section of the hot water pipe.* 2. Clean the water filter, and any dirt in the taps and also the water filters of the installation. 3. Check flue requirements are met. Long flue lengths, fluing with more than three elbows, blocked flue gas pipes or cross ventilation may cause this fault. 4. Check inlet gas pressure. Low gas pressure may prevent the heater from reaching its required output temperature.* 5. Check supply voltage. 6. Possible defective control unit, call Technical Support. 7. Ensure the hot water sensor is not fitted on any bends in the hot water pipe or incorrect readings causing an incorrect reading.
	Primary fan rotation too slow in operation.	<ol style="list-style-type: none"> 1. Disconnect power supply and check wiring connections on back of the fan and the two connectors on the control board. 2. Check supply voltage. 3. Check flue requirements are met. Long flue lengths, fluing with more than three elbows, blocked flue pipes or cross ventilation may cause this fault. 4. Ensure flue gas terminals maintain the required clearances stated in this manual. 5. Check inlet gas pressure. Low gas pressure may cause the fan to change its speed to meet its required temperature.* 6. Possible defective control unit, call Technical Support*.
	No rotation sensor signal from primary fan.	<ol style="list-style-type: none"> 1. Disconnect power supply and check wiring connections on back of the fan and the two connectors on the control board.* 2. Check supply voltage. 3. Possible defective component in fan or defective control unit, call the Technical Support*.
(Flashing) 	Water flow signal exceeds specified maximum value. Water flow > 37 l/min.	<ol style="list-style-type: none"> 1. Disconnect power supply and check wiring connections on the water valve and the two connectors on the control board. 2. Excessive water pressure and flow. Ensure water pressure is less than 10 bar and flow rate is below 37 litres per minute.*
	Software/hardware failure.	<ol style="list-style-type: none"> 1. Disconnect power supply cord and check the live, neutral and earth connections on control board as well as earth connection on heater chassis. 2. Incorrect setting of control parameters can cause problems with the water heater controller. Turn off the water heater. Turn water heater back on and try resetting error code. Use the reset button () to reset any error codes. 3. Possible defective control unit, call the Technical support.





Tab. 27

* By qualified registered gas engineer only.

Display	Cause	Solution
	Hot water temperature sensor (NTC) on the hot water outlet of the appliance detect a high temperature of the hot water. Temperature > 85°C	<ol style="list-style-type: none"> 1. Check the sensor is located and fixed correctly. 2. Check the electrical connections and connectors of the hot water temperature sensor. Clean terminals. If the terminals are corroded, replace the sensor and cables. Check electrical resistance (→ Fig. 3, pos. 2).* 3. Clean the water filter, any dirt in the taps and also the water filters of the installation. 4. In areas where water has a high mineral content, periodic descaling may be necessary.*
	Cold water inlet temperature sensor fault.	<ol style="list-style-type: none"> 1. Check connector on wires coming from top of water valve for a secure connection. 2. Sensor may trip if water temperature drops below 2°C. Protect heater from freezing conditions as any damage caused by freezing conditions is not covered by the warranty. 3. Check temperature sensor for any visible damage.
	Flue gas temperature sensor - the burner will be locked if the reading gets over 90°C.	<ol style="list-style-type: none"> 1. Check and clean the primary heat exchanger. 2. Check and clean the condensing heat exchanger. 3. Reduce maximum output. 4. Reduce water temperature setpoint.
	Burner backflow temperature sensor over 130°C. The appliance will lock out the burner.	<ol style="list-style-type: none"> 1. Check flue gas system. 2. Check if secondary fan connections are connected. 3. Check if flue requirements are met. Long flue lengths, flueing with more than three elbows, blocked flue pipes or cross ventilation may cause this fault. 4. Call Technical Support.
	High temperature sensor (ECO) open circuit (resets when lower temperatures than 104 °C are detected).	<ol style="list-style-type: none"> 1. Disconnect power supply and check wiring connections on the overheat sensor and the two connectors on the control board. (→ Fig. 2, pos. 7). 2. Check white wiring connections at the overheat sensor. Clean the terminals. If badly corroded, replace sensor and wiring harness.* 3. Check that flue requirements are met. Long flue lengths, flueing with more than three elbows, blocked flue pipes or cross ventilation may cause this fault. 4. Clean the water filter, any dirt in the faucets and also the water filters in the installation. 5. In areas where water has a high mineral content, periodic descaling may necessary.* 6. Disconnect power supply to the water heater. Open a hot water tap for several minutes to allow cold water to pass through heat exchanger. Close hot water tap and disconnect lead wires to overheat sensor. Using a multimeter, check continuity through the overheat sensor contacts. Replace sensor if continuity shows up.

Tab. 27

* By qualified registered gas engineer only.

Display	Cause	Solution
	No flame ionization detected when water flowing.	<ol style="list-style-type: none"> 1. Verify that all manual gas isolation valves are open. 2. Check gas type. 3. Check inlet gas pressure.* 4. Reset fault code and open a hot water tap to cycle the heater in an effort to release air from the hot water system. Cycling hot water tap on and off multiple times may be necessary. If heater still shows fault code EA, have a Gas Safe registered engineer properly purge the gas line leading to the water heater. 5. Check three wiring connections on the lower front of the heat exchanger are secure. 6. Check flue requirements are met. Improper flueing may cause premature failure of the flame sensor rod. 7. Check the minimum power fan speed has been adjusted to the proper value. (→ chapter 9.7). 8. Inspect the inside of the combustion through the sight glass. Sparking should be followed by a steady blue flame. If flame is unstable/yellow with sufficient gas pressure, check CO₂ readings.*
	Ionization failure during operation.	<ol style="list-style-type: none"> 1. Check gas type. 2. Check inlet gas pressure.* 3. Check three wiring connections to ignition group on the lower front of the heat exchanger are secure. 4. Verify that flue requirements are met. Improper flueing may cause premature failure of the flame sensor rod. 5. Check the minimum power fan speed has been adjusted to the correct value. (→ chapter 9.7).* 6. Check CO₂ readings.
	Ionization fault at standby.	<ol style="list-style-type: none"> 1. Undo connection to the flame ionization sensor. Verify that the thinner wire leading from the control unit is securely connected to the electrodes located on the lower front of the heat exchanger. 2. Flame ionization sensor or control unit may be damaged. Call Technical Support.
	Gas leakage error, gas valve circuit not closing properly.	<ol style="list-style-type: none"> 1. Disconnect power supply and check wiring connections on gas valve and the two connectors on the control board. 2. Draw water from a hot water tap above the minimum activation point (1.9 l/m). Measure voltage at the gas valve wiring connection. The voltage should measure 24VDC between the left pair of wires and 24VDC between the right pair of wires when the unit is in operation. If voltage is not insufficient, call the Technical Assistance.* 3. Gas valve may be defective, call Technical Support.

Tab. 27

* By qualified registered gas engineer only.

12 HOT WATER FUNCTION

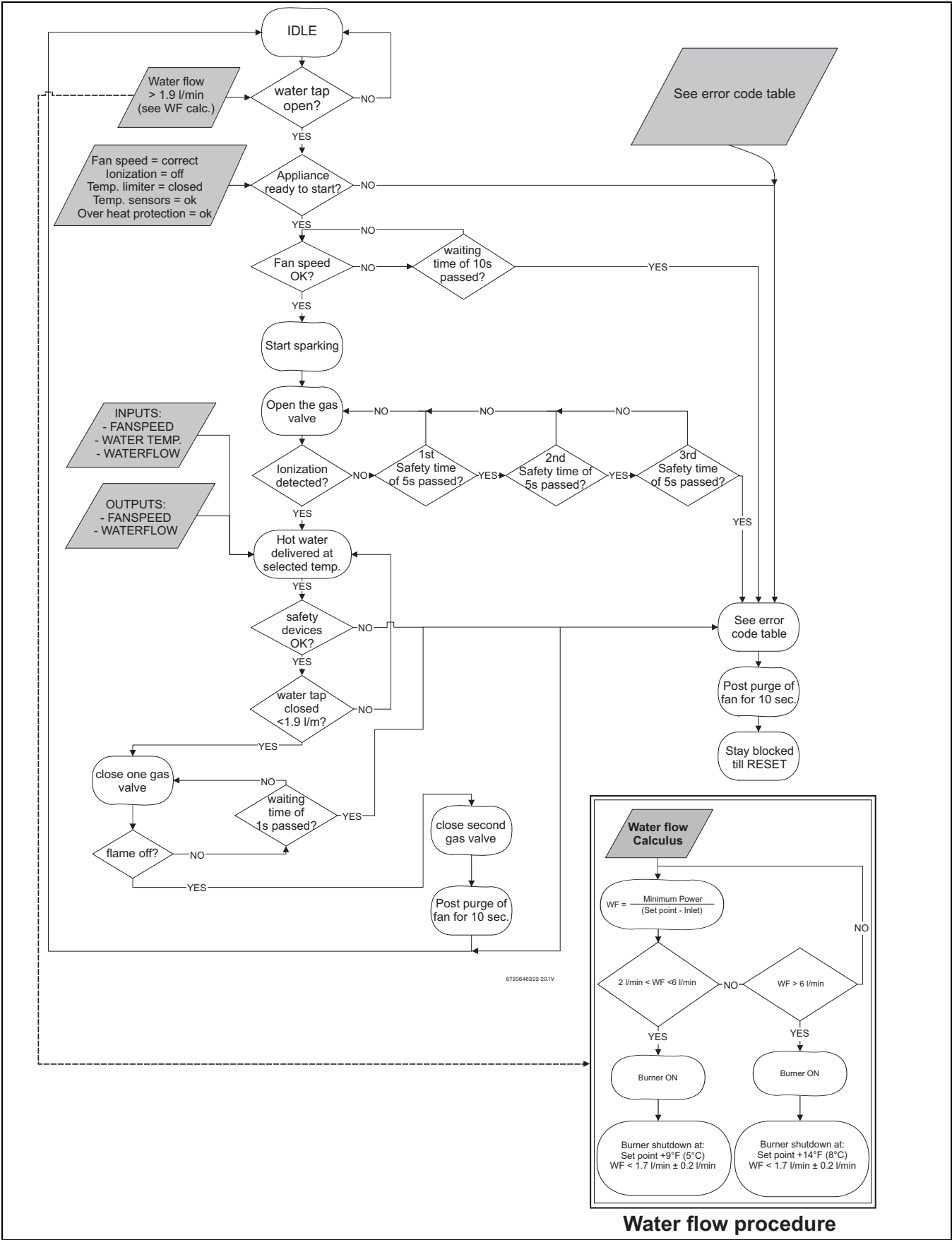

Fig. 75

13 ENVIRONMENTAL PROTECTION

Environmental protection is a fundamental corporate strategy of the Bosch Group.

The quality of our products, their economy and environmental safety are all of equal importance to us and all environmental protection legislation and regulations are strictly observed.

We use the best possible technology and materials for protecting the environment taking account of economic considerations.

PACKAGING

We participate in the recycling programmes of the countries in which our products are sold to ensure optimum recycling. All of our packaging materials are environmentally compatible and can be recycled.

OLD APPLIANCES

Old appliances contain valuable materials that should be recycled.

The assemblies can be easily detached and synthetic materials are marked accordingly. The assemblies can therefore be sorted out and passed on for recycling or disposal.

14 GREENSPRING WATER HEATER GUARANTEE

The Greenspring water heater has a guarantee against faulty materials or workmanship for a period of two years from the date of installation subject to the following terms and conditions:

- During the period of this guarantee any components of the Greenspring water heater which are proven to be faulty or defective in manufacture will be exchanged or repaired free of charge by Bosch Thermotechnology Ltd.
- The user may be asked to prove the date of installation, that the Greenspring water heater was correctly commissioned and, where appropriate, the first year's service has been carried out to the satisfaction of Bosch Thermotechnology Ltd., when requested. These should be documented as a part of the Benchmark Checklist.
- The Greenspring water heater has been used only for the purposes for which it was designed.

This guarantee does not affect your statutory rights.

GUARANTEE REGISTRATION

The Greenspring water heater carries a two year guarantee against faulty material or manufacture subject to Terms and Conditions.

To read the full Terms & Conditions please visit us online at www.worcester-bosch.co.uk/guarantee.

The Guarantee Registration form is available on this same page and can be completed and submitted electronically.

Alternatively please telephone one of our Guarantee Registration advisors on 0844 892 2552.

Your statutory rights are not affected by the manufacturers guarantee.

Service Record

It is recommended that your heating system is serviced regularly and that the appropriate Service Interval Record is completed.

Service Provider

Before completing the appropriate Service Record below, please ensure you have carried out the service as described in the manufacturer's instructions.

Always use the manufacturer's specified spare part when replacing controls.

Service 1

Date: _____

Engineer Name: _____

Company Name: _____

Telephone No. _____

Gas Safe Register No. _____

Comments: _____

Signature: _____

Service 2

Date: _____

Engineer Name: _____

Company Name: _____

Telephone No. _____

Gas Safe Register No. _____

Comments: _____

Signature: _____

Service 3

Date: _____

Engineer Name: _____

Company Name: _____

Telephone No. _____

Gas Safe Register No. _____

Comments: _____

Signature: _____

Service 4

Date: _____

Engineer Name: _____

Company Name: _____

Telephone No. _____

Gas Safe Register No. _____

Comments: _____

Signature: _____

Service 5

Date: _____

Engineer Name: _____

Company Name: _____

Telephone No. _____

Gas Safe Register No. _____

Comments: _____

Signature: _____

Service 6

Date: _____

Engineer Name: _____

Company Name: _____

Telephone No. _____

Operative ID No. _____

Comments: _____

Signature: _____

Service 7

Date: _____

Engineer Name: _____

Company Name: _____

Telephone No. _____

Gas Safe Register No. _____

Comments: _____

Signature: _____

Service 8

Date: _____

Engineer Name: _____

Company Name: _____

Telephone No. _____

Gas Safe Register No. _____

Comments: _____

Signature: _____

Service 9

Date: _____

Engineer Name: _____

Company Name: _____

Telephone No. _____

Gas Safe Register No. _____

Comments: _____

Signature: _____

Service 10

Date: _____

Engineer Name: _____

Company Name: _____

Telephone No. _____

Gas Safe Register No. _____

Comments: _____

Signature: _____

WATER HEATER COMMISSIONING CHECKLIST

This Commissioning Checklist is to be completed in full by the competent person who commissioned the water heater as a means of demonstrating compliance with the appropriate Building Regulations and then handed to the customer to keep for future reference.

Failure to install and commission this equipment to the manufacturer's instructions may invalidate the warranty but does not affect statutory rights.

Customer Name _____ Telephone Number _____

Address _____

Water Heater Make and Model _____

Serial Number _____

Commissioned by (print name) _____ Gas Safe Register Number _____

Company Name _____ Telephone Number _____

Company Address _____ Commissioning Date _____

To be completed by the customer on receipt of a Building Regulations Compliance Certificate*:

Building Regulations Notification Number (if applicable) _____

DOMESTIC HOT WATER Measure and Record:

Gas Rate _____ m³/hr OR _____ ft³/hr

Gas Inlet Pressure (at maximum rate) _____ mbar

Cold Water Inlet Temperature _____ °C

Hot water has been checked at all outlets Yes Temperature _____ °C

Water Flow Rate _____ l/min

CONDENSATE CONNECTION

The condensate drain has been installed in accordance with the manufacturer's instructions and/or BS5546/BS6798 Yes

ALL INSTALLATIONS

If required by the manufacturer, record the following CO₂ _____ % OR CO _____ ppm OR CO/CO₂ Ratio _____

The hot water system complies with the appropriate Building Regulations Yes

The water heater and associated products have been installed and commissioned in accordance with the manufacturer's instructions Yes

The operation of the water heater controls have been demonstrated to and understood by the customer Yes

The manufacturer's literature, including Commissioning Checklist and Service Record, has been explained and left with the customer Yes

Commissioning Engineer's Signature _____

Customer's Signature _____

(To confirm satisfactory demonstration and receipt of manufacturer's literature)

*All installations in England and Wales must be notified to Local Authority Building Control (LABC) either directly or through a Competent Persons Scheme. A Building Regulations Compliance Certificate will then be issued to the customer.



6720646322

WORCESTER, BOSCH GROUP:

TECHNICAL SUPPORT: 0844 892 3366

APPOINTMENTS: 0844 892 3000

SPARES: 01905 752571

LITERATURE: 0844 892 9800

TRAINING: 01905 752526

SALES: 01905 752640

Worcester, Bosch Group
Cotswold Way, Warndon, Worcester WR4 9SW.
Tel. 0844 892 9900
Worcester, Bosch Group is a brand name of Bosch Thermotechnology Ltd.

worcester-bosch.co.uk

6 720 646 322

